

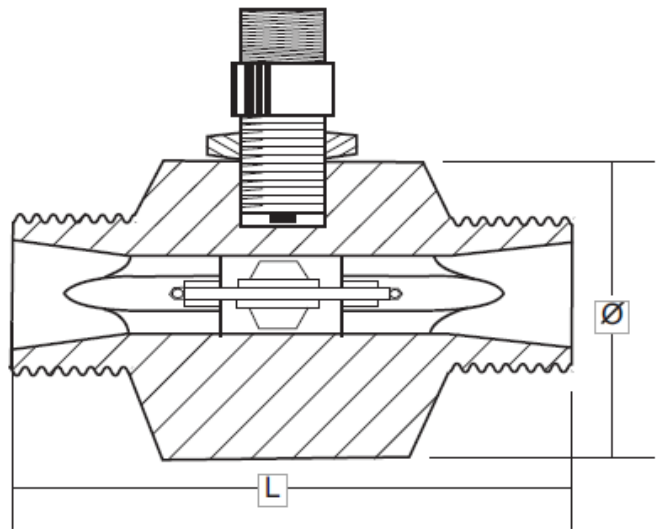

SCREWED LIQUID TURBINE FLOW METER

This range of Screwed flow meters will provide you with a highly accurate and economical way of measuring liquids over the range of 1 to 2250 litres/min.

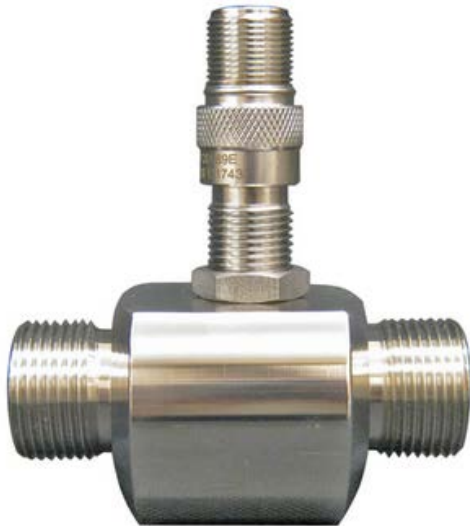

Specification

Linearity:	Better than +/- 0.5% of reading
Repeatability:	+/-0.1% of reading
Pressure drop:	0.5 Barg at maximum flow
Maximum over range:	Up to 120% of the maximum flow rate for short durations
Maximum working pressure:	35 Barg (special high pressure designs available)
Temperature range:	Standard pickoff -30 to 110 degC / High temp -30 to 232 degC
Body connections:	BSP parallel thread with 60-degree cone. Special connections are available.

Materials of Construction

Body:	316 Stainless Steel
Sleeve bearings:	Tungsten Carbide
Thrust balls:	Tungsten Carbide
Rotor:	431 Stainless Steel or Ferralium
Rotor shaft:	Tungsten Carbide
Hangers:	316 Stainless Steel
Circlip's:	316 Stainless Steel

Application

This range of flow meters is used for liquids such as water, light oils, solvents and low viscosity chemicals. You can use them for batching, flow rate monitoring, controlling, blending and filling. The flowmeter is highly accurate and often used for testing the performance of pumps, engines, valves and other flowmeters.

In hazardous areas you can use the flow meters with the IS pick-off coil approved to ATEX II 1G Ex ia IIC T5/T4 Ga (-20C<Ta<80C/+100C). The signal can be used in the IS area or transmitted to the safe area using the intrinsically safe P5 preamplifier and suitable barriers.

Instrumentation

The signal can be used for a local display, remote display or converted for transmission to a separate control system. We have a range of instruments to suit all your requirements.

Principle of Operation

When liquid flows and the rotor turns, the sensor detects the movement of the blade tips and generates pulses. The frequency of the pulses is proportional to the flowrate.

Construction

The stainless-steel construction is durable and gives excellent corrosion resistance. The rotor is machined from solid making it virtually indestructible. The sleeve bearings provide you with highly reliable performance over long periods.

Calibration

The turbine flow meters are individually calibrated with water and are traceable to national standards. They are supplied with a test certificate for each meter showing the number of pulses per litre, which is used to set the instrumentation.

Installation

The flow meter is installed directly into the pipeline. To reduce turbulence and get the best results from your flow meter we recommend that you install it in a straight section of pipe with at least 10 pipe diameters upstream and 5 pipe diameters downstream. Control valves should be installed downstream of the flowmeter.

To prevent foreign particles blocking your line we recommend you install a filter before the flow meter.

Preamplifiers are only needed if you have very long transmission distances or an electrically noisy environment close to pumps, motors, generators, switchgear or heavy current carrying cables. Intrinsically safe systems always require an IS pick-off coil. The IS P5 preamplifier is required for transmission to a safe area through barriers.

Model No	Flow Range Ltr/min	K factor pulses / litre [#]
F3/15/1	1-10	6000
F3/15/2	2-20	3000
F3/20/5	5-50	1080
F3/20/8	8-80	1080
F3/25/15	15-150	520
F3/25	25-250	362
F3/32	45-450	102
F3/40	67-670	72
F3/50	110-1100	41
F3/80	225-2250	16

Model Number	Thread Size BSP	L mm	Dia mm	Weight kg
F3/15/1	1/2"	82.6	50.0	0.7
F3/15/2	1/2"	82.6	50.0	0.7
F3/20/5	3/4"	82.6	50.0	0.7
F3/20/8	3/4"	82.6	50.0	0.7
F3/25/15	1"	90.5	63.5	1.2
F3/25	1"	90.5	63.5	1.1
F3/32	1 1/4"	110.0	75.0	1.6
F3/40	1 1/2"	116.7	76.2	1.7
F3/50	2"	154.0	89.0	3.1
F3/80	3"	200.0	120.0	10

The nominal K factor is based on water at 20°C
Each flowmeter is individually calibrated on water
and will have a unique K factor.