

### Fig. 913 Straight Through Sight Flow Indicator with Integral Spout - Cast Iron

This two sided flow indicator features an integral spout that produces a jetting action for turbulent flow thereby improving the viewing of clear liquids.

#### FEATURES & BENEFITS

- The large viewing area allows the flow, colour and condition of the liquid to be observed, enabling the monitoring of product quality and consistency.
- This indicator is suitable for both vertical and horizontal installation. The inclusion of a spout allows for use as a drip indicator to show valve leaks, distillation or similar conditions.
- Available with flanged end connections, see table for further detail.

**For product application please refer to pages 30 and 31.**



Fig.913 Cast Iron

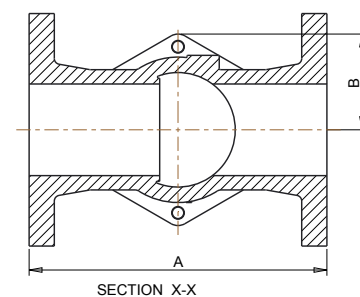
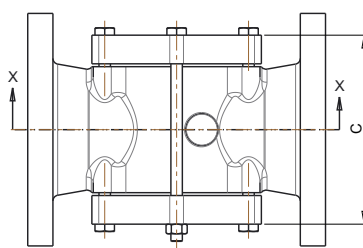

#### TEMPERATURE RATINGS

Max Pressure 16 Barg	Min. Temperature	Max. Temperature
	0°C	180°C

#### DIMENSIONS

Flanged (mm)	Length A (mm)	Max Height from Centre B (mm)	Max Width C (mm)	Weight (kg)
25	140	38	94	3.5
40	180	45	120	6.5
50	220	56	135	10.5
80	260	86	186	20.5
100	310	94	224	35.5

Every effort has been made to ensure that the information contained in this publication is accurate at the time of publishing. Rhodes assumes no responsibility or liability for typographical errors or omissions or for any misinterpretation of the information within the publication and reserves the right to change without notice.

### MATERIALS OF CONSTRUCTION

ITEM NO.	DESCRIPTION	BODY MATERIAL	MATERIAL	QTY
1	Body	Cast Iron	BS EN 1561 EN-GJL-250	1
2	Cover	Mild Steel	BS EN 10025 S355 J2G3	2
3	Glass Disc	Toughened Soda Lime	BS3463	2
		Toughened Borosilicate	DIN7080	
4	Nut	Mild Steel Zinc Plated		4
5	Bolt	Mild Steel Zinc Plated (quantity depends on size)		4
6	Gasket	Nickel Reinforced Graphite		4
		PTFE		

### END CONNECTIONS

#### FLANGED

- ANSI 150RF
- ANSI 150FF
- PN16 BS EN 1092
- Table D BS10
- Table E BS10
- Table F

N.B. Models 913 is not available with screwed ends.

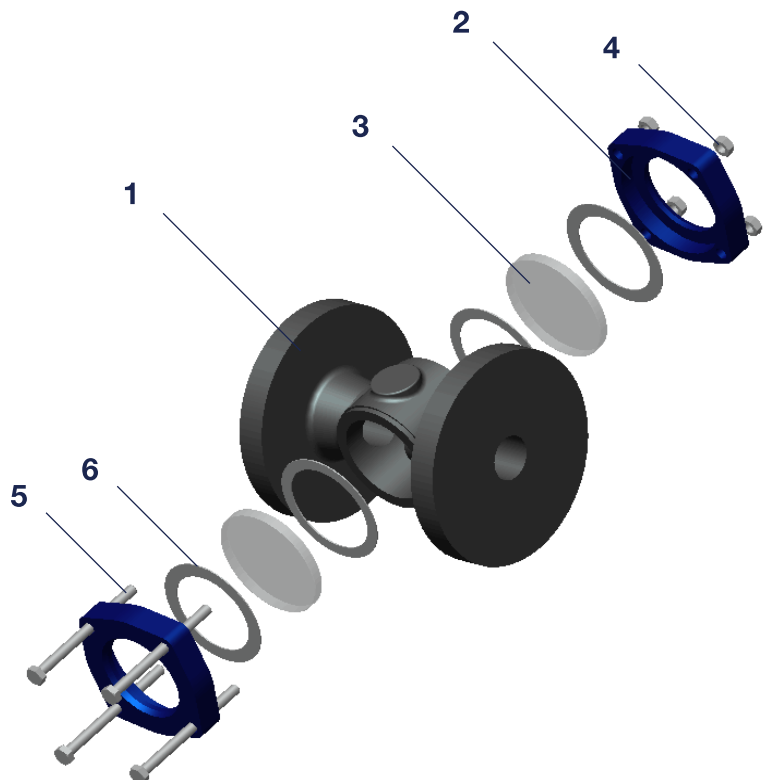

### APPROVALS



FM00311 ISO 9001



ISO 14001 Reg No. EMS 78657

Every effort has been made to ensure that the information contained in this publication is accurate at the time of publishing. Rhodes assumes no responsibility or liability for typographical errors or omissions or for any misinterpretation of the information within the publication and reserves the right to change without notice.