

Initial-Pressure-Controller, springloaded

for steam, gases and liquids

Typ 80 SMS

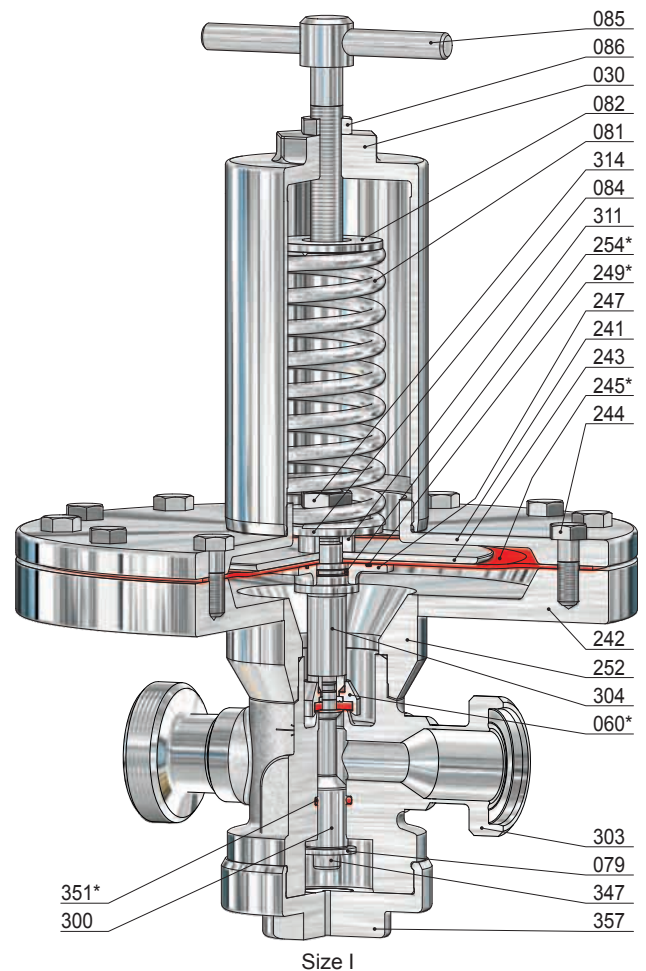
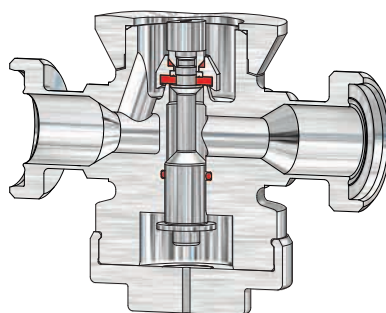
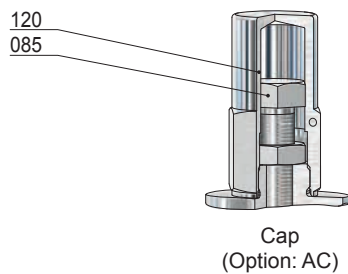

Item	Piece	Description	Item	Piece	Description
303	1	valve body	242	1	lower housing
030	1	spring bonnet	243	1	upper clamp plate
060 *	1	disc, complete	244	12	screw (<i>variable</i>)
560	1	disc	245 *	1	diaphragm
061	1	pressure piece	247	1	lower clamp plate
062	1	soft sealing	249 *	1	o-ring
071	1	o-ring	252	1	adapter
072	1	locking ring	254 *	1	o-ring
073	1	o-ring (<i>only for thermoplastics soft sealing</i>)	300	1	piston
079	1	lift stopper	304	1	inlet pressure piston
081	1	spring	311	1	distance bush
082	1	springplate, upper	314	1	lock nut
084	1	springplate, lower	347	1	screw
085	1	adjusting screw	351 *	1	o-ring
086	1	lock nut	357	1	bottom plug
120	1	cap			
241	1	upper housing			

* expendable parts

Initial-Pressure-Controller, springloaded

for steam, gases and liquids

Typ 80 SMS

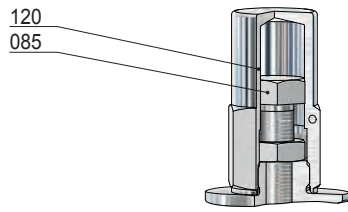

Cap
(Option: AC)

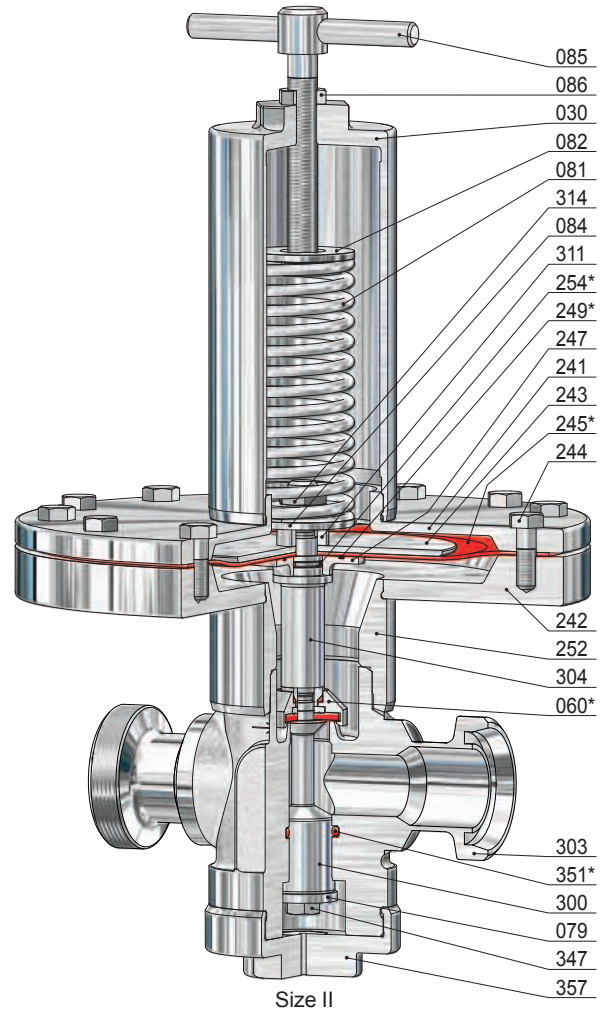
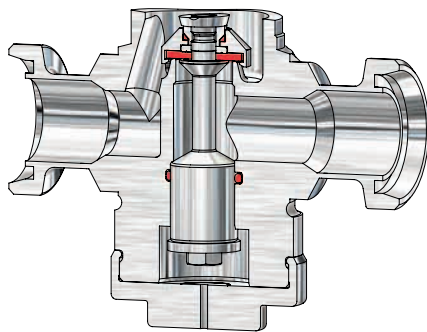

Item	Piece	Description	Item	Piece	Description
303	1	valve body	242	1	lower housing
030	1	spring bonnet	243	1	upper clamp plate
060 *	1	disc, complete	244	12	screw (<i>variable</i>)
560	1	disc	245 *	1	diaphragm
061	1	pressure piece	247	1	lower clamp plate
062	1	soft sealing	249 *	1	o-ring
071	1	o-ring	252	1	adapter
072	1	locking ring	254 *	1	o-ring
073	1	o-ring (<i>only for thermoplastics soft sealing</i>)	300	1	piston
079	1	lift stopper	304	1	inlet pressure piston
081	1	spring	311	1	distance bush
082	1	springplate, upper	314	1	lock nut
084	1	springplate, lower	347	1	screw
085	1	adjusting screw	351 *	1	o-ring
086	1	lock nut	357	1	bottom plug
120	1	cap			
241	1	upper housing			

* expendable parts

Initial-Pressure-Controller, springloaded

for steam, gases and liquids

Typ 80 SMS

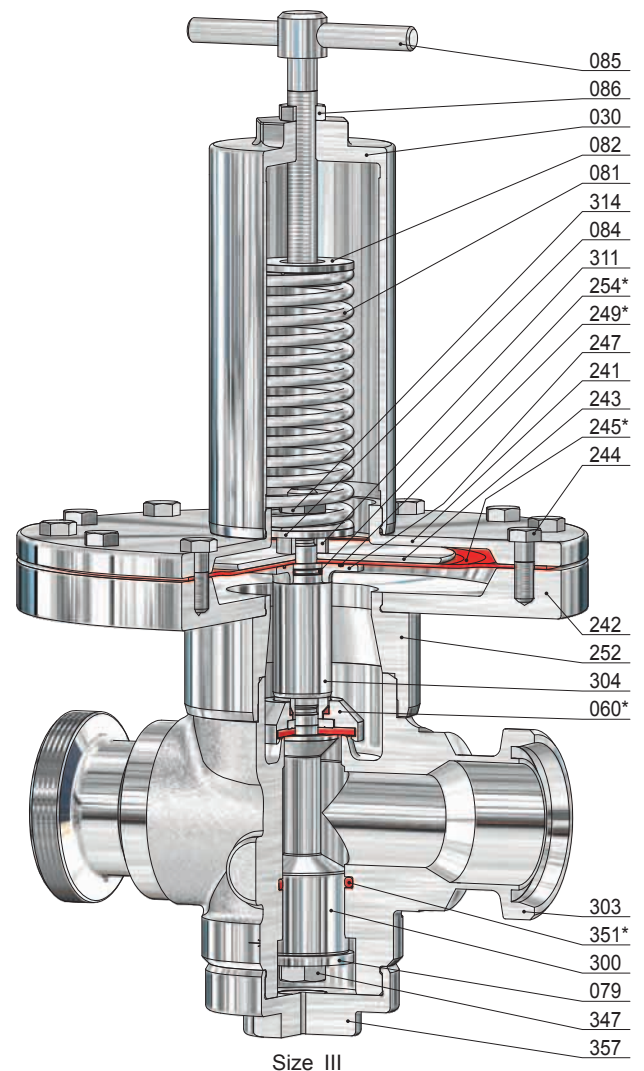
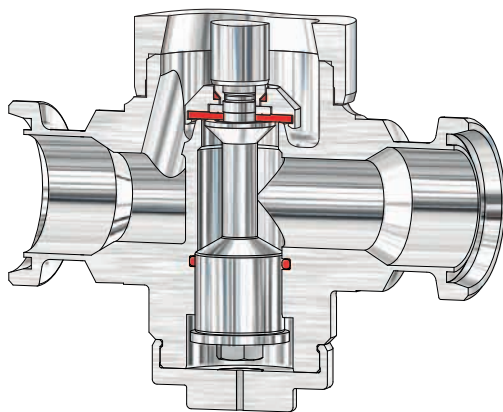
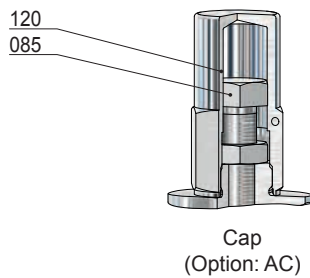

Item	Piece	Description	Item	Piece	Description
303	1	valve body	242	1	lower housing
030	1	spring bonnet	243	1	upper clamp plate
060 *	1	disc, complete	244	12	screw (<i>variable</i>)
560	1	disc	245 *	1	diaphragm
061	1	pressure piece	247	1	lower clamp plate
062	1	soft sealing	249 *	1	o-ring
071	1	o-ring	252	1	adapter
072	1	locking ring	254 *	1	o-ring
073	1	o-ring (<i>only for thermoplastics soft sealing</i>)	300	1	piston
079	1	lift stopper	304	1	inlet pressure piston
081	1	spring	311	1	distance bush
082	1	springplate, upper	314	1	lock nut
084	1	springplate, lower	347	1	screw
085	1	adjusting screw	351 *	1	o-ring
086	1	lock nut	357	1	bottom plug
120	1	cap			
241	1	upper housing			

* expendable parts

Initial-Pressure-Controller, springloaded

for steam, gases and liquids

Typ 80 SMS

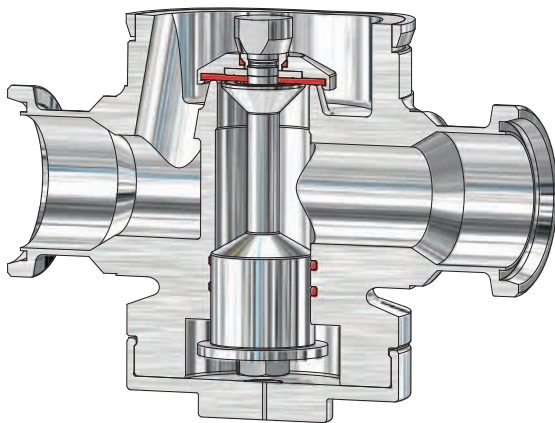
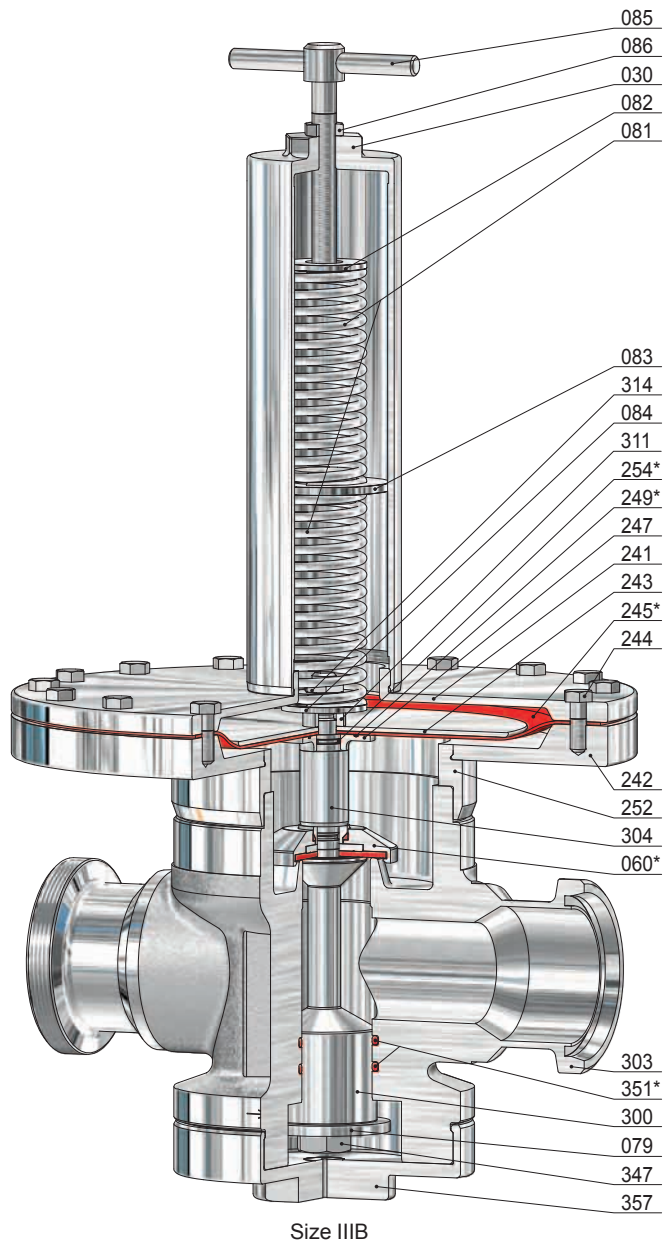
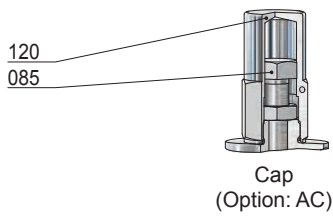

Item	Piece	Description	Item	Piece	Description	Item	Piece	Description
303	1	valve body	083	1	springplate, middle	300	1	piston
030	1	spring bonnet	084	1	springplate, lower	304	1	inlet pressure piston
060 *	1	disc, complete	085	1	adjusting screw	311	1	distance bush
560	1	disc	086	1	lock nut	314	1	lock nut
061	1	pressure piece	120	1	cap	347	1	screw
062	1	soft sealing	241	1	upper housing	351 *	2	o-ring
071	1	o-ring	242	1	lower housing	357	1	bottom plug
072	1	locking ring	243	1	upper clamp plate			
073	1	o-ring (only for thermoplastics soft sealing)	244	16	screw (variable)			
079	1	lift stopper	245 *	1	diaphragm			
081	2	spring	247	1	lower clamp plate			
082	1	springplate, upper	249 *	1	o-ring			
			252	1	adapter			
			254 *	1	o-ring			

* expendable parts