

# MEDENUS

Gas Pressure Regulation



## Safety shut-off valve S 100



Operating and Maintenance Instructions

EN



# Table of Contents

<b>1 General Information</b>	<b>4</b>
1.1 Warranty and Liability	4
1.2 Symbols, Notes	5
1.3 Terms, Abbreviations	5
<b>2 Safety Instructions</b>	<b>6</b>
2.1 Hazards of Handling the Device	6
2.2 Personnel Requirements	6
2.3 Country-Specific Requirements	6
2.4 Handover of the Operating and Maintenance Instructions	6
2.5 Safety in Operation	7
2.6 What To Do in Case of Danger	7
<b>3 Responsibility of the Operator</b>	<b>7</b>
<b>4 Transport, Storage and Packaging</b>	<b>8</b>
4.1 Transport	8
4.2 Storage	8
4.3 Packaging	8
<b>5 Mounting and Commissioning</b>	<b>9</b>
5.1 Safety Instructions and Preparation	9
5.2 Mounting	10
5.3 Leakage Test (Test for External Leakage)	11
5.4 Initial Commissioning / Recommissioning	12
5.5 Decommissioning	13
<b>6 Maintenance</b>	<b>14</b>
6.1 Maintenance Plan	14
6.2 Maintenance Procedure	14
6.3 Table of Screw Tightening Torques $M_A$	15
6.4 Lubricants Table	15
6.5 Screw Retention	15
<b>7 Replacement and Disposal</b>	<b>15</b>
<b>8 Troubleshooting</b>	<b>16</b>
<b>9 Spare Parts</b>	<b>17</b>
9.1 Spare Part Drawing of Safety Shut-Off Valve SSV	17
9.2 Parts for Maintenance Work	18
Valve Plate SSV / Diaphragm SSV	18
O-Rings and Sealing Rings	18
<b>10 Notes</b>	<b>19</b>
<b>11 Declaration of Conformity</b>	<b>20</b>

# 1 General Information

The personnel entrusted with installation, operation or maintenance of the safety shut-off valve must have completely read and understood beforehand the following documents:

- **Safety Shut-Off Valve S 100 Product Information**  
The product information contains technical data, dimensions and a description of the design and the mode of operation.
- **Safety Shut-Off Valve S 100 Operating and Maintenance Instructions**  
This document allows safe and efficient handling of the device and contains information on assembly, commissioning, maintenance, troubleshooting and repair according to regulations.  
It is an integral part of the scope of delivery of the device, must be kept in close proximity of the device and must be readily accessible to personnel at any time.  
The basic requirement of safe operation is compliance with all safety instructions and guidelines specified in these instructions. Accordingly, the information and instructions must be observed when working on the device or on the gas line. In addition, the local occupational safety regulations and the general safety regulations for the application range of the device shall apply.  
The figures in these instructions are provided for basic understanding and may differ from the actual design.  
The contents in these instructions are protected by copyright. They may be used as part of operating the device. Any other use and / or reproduction is not permitted without prior authorization by the MEDENUS Gas-Druckregeltechnik GmbH.

## 1.1 Warranty and Liability

Claims under warranty or liability for personal injury and material damage are generally void, **if one or several of the following conditions are not observed:**

- Work on the device during the warranty period may only be performed in consultation with the manufacturer
- Designated use of the device in accordance with the established conditions of use
- Proper installation, commissioning, operation and maintenance of the device
- Operation of the device with properly installed and functioning safety devices only
- Operating and maintenance instructions of the device or of the system
- Observance of the maintenance instructions
- Properly performed repairs
- Supply lines without defects
- The use of original MEDENUS® spare parts and lubricants listed in these instructions or
- Force majeure

### **It is generally prohibited**

- to perform constructive modifications on the device
- to keep using the device despite the detection of a defect

## 1.2 Symbols, Notes

The instructions contain safety instructions marked with symbols to indicate possible consequences in case of non-observance:

This combination of symbol and signal word indicates a potentially hazardous situation which may result in light injuries, damage to the device, the breakdown of the system, and material or environmental damage if not avoided.



**NOTICE**

This combination of symbol and signal word indicates an imminent hazardous situation, resulting in death or serious injuries if not avoided.



**DANGER**

This signal word highlights useful tips, recommendations and information for efficient and trouble-free operation.

**Note**

## 1.3 Terms, Abbreviations

Terms and abbreviations are explained below:

ATC	Acceptance test certificate	$p_d$	Outlet pressure	SSV	Safety shut-off valve
DN	Nominal width	$p_{ds}$	Setpoint of the outlet pressure		
GPR	Gas pressure regulator	MOP	Maximum operating pressure in a system		
$M_A$	Screw tightening torque				

## 2 Safety Instructions

National accident prevention regulations and the system operator's safety regulations are not superseded by these operating and maintenance instructions and must be taken into consideration with priority (in Germany, see, among others, DVGW Code of Practice G 600, G 459/II, G 491 and G 495).

When performing work on the device, the current general and specific safety regulations must be observed.

The application limits of the device with respect to the medium, operating pressure and operating temperature can be found on the type plate affixed to the device or on the acceptance test certificate.

Using the device under different operating conditions must be agreed upon in consultation with MEDENUS Gas-Druckregeltechnik GmbH.

The mechanical components of the device do not have any potential ignition sources of their own nor any hot surfaces and are thus not within the scope of 2014/34/EU (ATEX). The electronic accessories used comply with the ATEX requirements.

### 2.1 Hazards of Handling the Device

MEDENUS® devices conform with current standards and directives, the recognized technical rules and the recognized safety rules.

However, improper use can result in hazards to the user or to third parties. This can also result in damage to the device or to the system.

This is why the device may only be used:

- in accordance with its designated use
- in perfect condition
- while observing the notes given in these operating and maintenance instructions, and inspection and maintenance regulations, which apply to the functioning and safety of the overall system.

Malfunctions or faults must be eliminated immediately.

### 2.2 Personnel Requirements

The device may only be mounted by qualified personnel.

Only authorised personnel in possession of the required qualification is allowed to perform settings or repairs on the device.

### 2.3 Country-Specific Requirements

The rules and regulations applicable at the place of use with respect to

- gas lines, installation of the gas system,
- gas supply,
- work on the gas system,
- accident prevention must be observed and complied with.

### 2.4 Handover of the Operating and Maintenance Instructions

The supplier of the system shall hand over these operating and maintenance instructions to the operator of the system no later than during commissioning and training of the operating personnel with the reminder to carefully store these instructions.

## 2.5 Safety in Operation

The device may only be used when all protective devices on the device or in the system are fully functional.

The device must be inspected by a representative of the manufacturer or by a qualified person for externally visible damage and for proper functioning at least once a year.

A more frequent inspection may become necessary, depending on the system conditions.

## 2.6 What To Do in Case of Danger

Information on what is to be done in case of danger and in case of accidents can be found in the respective operator's or specialist companies' work instructions.

## 3 Responsibility of the Operator

**Operator** An operator is a person who operates the device himself for commercial or economic purposes or hands it over to a third party for use / application and is legally responsible for the safety of the user, personnel or third parties.

**Operator's obligations** The device is used in the industrial sector. Accordingly, the operator of the device is subject to the legal obligations concerning occupational safety. In addition to the safety instructions contained in these instructions, the established maintenance intervals must be observed, taking into account the respective national standard (alarm and hazard prevention plan).

In particular, the following applies:

- The operator is obliged to perform work on MEDENUS® devices during the warranty period only after consultation with the manufacturer. Otherwise the claims under warranty will become void.
- The operator must obtain information on the current occupational safety regulations and determine additional hazards resulting from the special work conditions at the place of use of the device in a risk assessment. The operator must implement them in the form of operating manuals for operating the device.
- During the entire time of use of the device, the operator must check whether the operating manuals drawn up by him conform to the current state of the regulations and, if necessary, adapt them.
- The operator must clearly regulate and define the responsibilities for installation, operation, troubleshooting, maintenance, and cleaning.
- The operator must ensure that all persons handling the device have read and understood these instructions. In addition to that, he must train the personnel at regular intervals and inform it about the dangers.
- The operator must make available to the personnel the required protective equipment and oblige them to wear the required protective equipment.
- Moreover, the operator is responsible for the device always being in technically perfect condition.

Therefore, the following applies:

- The operator must make sure that the maintenance intervals described in these instructions are observed.
- The operator must have all safety devices checked regularly for functioning and completeness.

## 4 Transport, Storage and Packaging

### 4.1 Transport

The device is delivered with flange protective caps. They must be removed prior to installation. Make sure that the device is transported horizontally using suitable lifting gear. The device must be handled carefully and secured against impact and shock.

#### Note

In case of transport damage, we will require the following information from the type plate affixed to the device:

- Type of device
- Device model
- Year of construction / fabrication number

### 4.2 Storage

**Equipment and spare parts must be stored under the following conditions:**

- Do not store outdoors.
- Store in a dry and dust-free location.
- Store on a flat surface.
- Do not expose to aggressive media.
- Do not expose to ozone or ionizing radiation.
- Do not store adjacent to direct heat sources.
- Avoid mechanical vibrations.
- Storage temperature: 0 to 25°C.
- Relative humidity: < 55 %.

**Spare parts:**

- Components susceptible to corrosion must be provided with a suitable preservative.
- Do not store O-rings and seals for more than 7 years even if stored properly.
- Spare parts must be stored in their original packaging until use.

**Storage period for devices:**

- Storage of the device for up to one year:  
Store the device in its original packaging and its original condition at the time of supply. All protective caps of the device must remain mounted.
- Storage of the device for more than 1 year (e.g. as a spare device):  
Store the device in its original packaging and original condition at the time of supply and check it for damage once a year. Check the housing surface for dirt, damage and corrosion. If necessary, clean all external parts. After 7 years, all O-rings and seals must be replaced.

### 4.3 Packaging

- The individual packaged items have been packaged in view of the transport conditions to be expected.
- The symbols on the packaging must be observed during transport and storage.
- Only environmentally-friendly materials have been used for packaging.
- The packaging is designed for protecting the individual components from transport damage, corrosion and other damage until mounting. This is why the packaging must not be destroyed and only be removed just prior to mounting.



## 5 Mounting and Commissioning

### 5.1 Safety Instructions and Preparation

Prior to starting work on pressurised components:

- Close all connections to the gas line.
- Depressurise all pressurised components. Also discharge residual energies.
- Defective components that are subject to pressure in operation must be replaced immediately by a suitable qualified person.

**DANGER**



Prior to starting work, ensure sufficient clearance for mounting.

Before installing the device, check whether the performance data (type plate) and the scope of delivery coincide with the order or the system data, i.e., make sure that the provided devices are suitable for their intended purpose. In particular, the inlet pressure of the system must be lower than the maximum allowable pressure of the device.

**Note**

A direct contact of gas valves and fittings, i.e., the control system, with hardening masonry, concrete walls or floors is not allowed. Provide suitable supports, working materials, and protective equipment. Take into account the minimum clearances for maintenance as stated in the product information. Before installing the device in the pipeline, check whether a shut-off device that interrupts the gas flow supply to the device has been mounted upstream and downstream of the device to be installed.

**Note**

Prior to commissioning, make sure that all installation work has been carried out and completed in accordance with the data and information given in these instructions and that no unauthorised persons stay in the danger zone.

**DANGER**



## 5.2 Mounting

- Remove packaging and protection from the connection flange surfaces.
- Install the device without tensioning the pipeline. Tighten screws crosswise. Make sure to observe the direction of flow, i.e. the arrow on the housing must point in the direction of flow.
- The tightening torques of the flange connections and additional information is available in the DVGW GAS information issue no. 19 (Flanged Connections in Gas Installations).

Note

Note

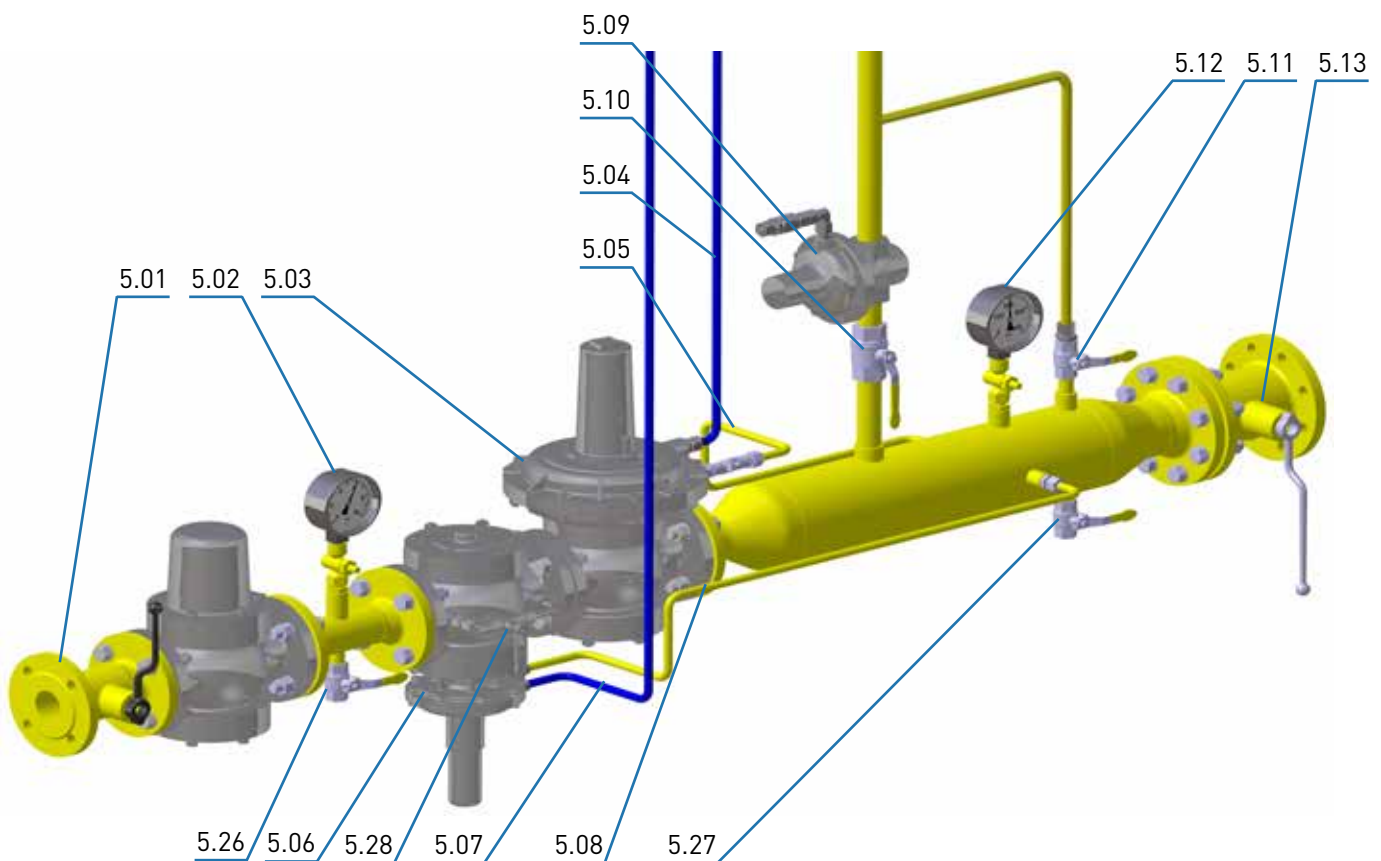

- A separate installation of the SSV breather line (item 5.07) is recommended.
- All breather lines (items 5.04 / 5.07) must be vented to the outside atmosphere.
- Breather lines (items 5.04 / 5.07) may not be required if breather valves or safety diaphragms are being used.
- The measuring lines (items 5.05 / 5.08) must be connected in a pipeline section with a steady flow. Directly upstream and downstream of the measuring point no flow-interfering built-in components may be present, such as orifice plates, pipe extensions, elbows, branches, shut-off valves, and the like.
- The maximum flow rate at the measuring point must not exceed 25 m/s, depending on the system conditions.
- In certain system circuits, such as gas control systems for gas motors and in gas burners, higher flow rates than 25 m/s are also possible. Please contact us.
- The measuring line must be connected to the pipeline separately, laterally or at the top for each device (1 gas pressure regulator (item 5.03); 1 SSV (item 5.06)).
- The SSV measuring line (item 5.08) must always be connected upstream of the shut-off valve (item 5.13) on the outlet side in such a way that it cannot be shut off.

### 5.3 Leakage Test (Test for External Leakage)

The devices are subjected to a strength and leakage test ex works at MEDENUS Gas-Druckregeltechnik GmbH.

The leakage test in the fully assembled system must be performed prior to commissioning and following maintenance work.

For the external leakage test in the fully assembled system, the following applies:

#### For Germany:

According to DVGW Code of Practice G 491, the fully assembled system must be subjected to a leakage test with air or an inert gas at the installation site, using 1.1 times the maximum operating pressure of the system (MOP).

An exception is the room between the actuator installed in the gas pressure regulator and the first shut-off valve on the outlet side. This room must be checked using the a test pressure corresponding to the maximum permissible pressure in the system in case of a malfunction (1.1 MOP<sub>d</sub>). In this test, all detachable connections must be checked using a foaming agent.

#### For other countries:

The relevant national and international standards shall apply.

#### Procedure

- Close the ball valves upstream of the valves and fittings (item 5.01).
- Close the downstream shut-off devices (item 5.13) (ball valves, solenoid or pneumatic valve).
- Depressurise the system (item 5.11).
- If there is a SRV (safety relief valve) in the controlled section and the test pressure is higher than the relief pressure of the SRV (item 5.09), the line upstream of the SRV (item 5.10) must be closed.
- Connect the testing device to measuring points upstream and downstream of the gas pressure regulator (items 5.26 / 5.27).
- Always increase the test pressure slowly and steadily.

#### While doing so, you must ensure:

Pressure in outlet chamber (item 5.12)  $\leq$  Pressure in inlet chamber (item 5.02)  
Pressure build-up always from the inlet side (inlet chamber)  
Pressure decrease always from the outlet side (outlet chamber)

- After leakage test:  
Open the ball valve in the SRV line (item 5.10) again.

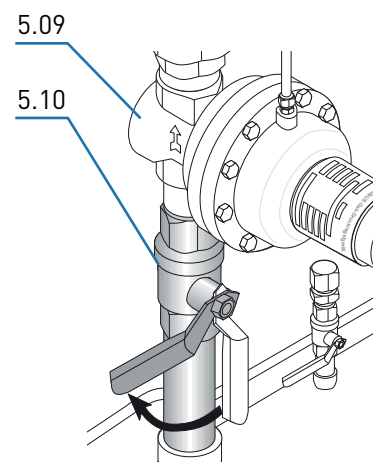

#### Note

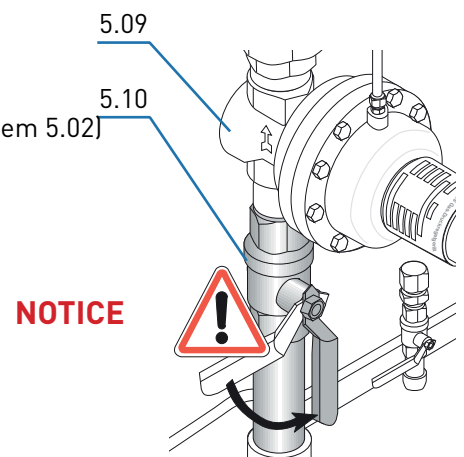

## 5.4 Initial Commissioning / Recommissioning

Initial commissioning of the system components shall be carried out by the operator. For commissioning, please refer to the documents listed under item 1 "General Information" and the system operator's work instruction.

The devices delivered by MEDENUS Gas-Druckregeltechnik GmbH are factory-set to the operating data specified by the customer. This data is listed on the Acceptance Test Certificate (ATC)\* and the type plate.

### Note

Prior to commissioning the system, a functional test must be performed on the gas pressure regulator (GPR) and the safety shut-off valves.

### Procedure

- Close the ball valves upstream of the valves and fittings (item 5.01).
- Close the downstream shut-off devices (item 5.13) (ball valves, solenoid or pneumatic valve).
- Depressurise the system (item 5.11).
- Close venting ball valve (item 5.11).
- Slowly open ball valve upstream of the valves and fittings (item 5.01).

### Note

If the inlet shut-off device is equipped with a bypass, the latter must be slowly opened for pressure compensation as step 1. This is followed by slowly opening the inlet shut-off valve. The same is true of the outlet shut-off valve.

- Check the inner leakage of the SSV (item 5.06) by reading the pressure gauge installed downstream of the GPR (item 5.12).
- Unscrew the sealing cap (item 5.15) of the safety shut-off valve (SSV).
- Perform pressure compensation by opening the ball valve (item 5.28) and engage the SSV by pulling the pull knob (item 5.14).
- The ball valve (item 5.28) automatically closes after being released.
- A closing pressure corresponding to the set value is established on the GPR.

### Note

An SSV with underpressure shut-off can only be engaged if the pressure at the measuring point exceeds the set value by at least the re-engagement differential.

- Testing the response pressure of the SSV by slowly increasing or decreasing the output pressure to response pressure.
- It may be necessary to correct the setpoint values of the response pressures. This is done by turning the SSV setpoint setting screws (items 5.17 / 5.19) to the right (pressure increase) or left (pressure decrease) in order to increase/decrease the setpoint value.

### Note

The inner setting screw (item 5.17) sets the underpressure shut-off level (lower trigger level) and the outer setting screw (item 5.19) sets the upper trigger level.

- Perform pressure compensation again by opening the ball valve (item 5.28) and engage the SSV by pulling the pull knob (item 5.14).
- Close the ball valve (item 5.28) again.

\*) Acceptance Test Certificate (ATC) available optionally

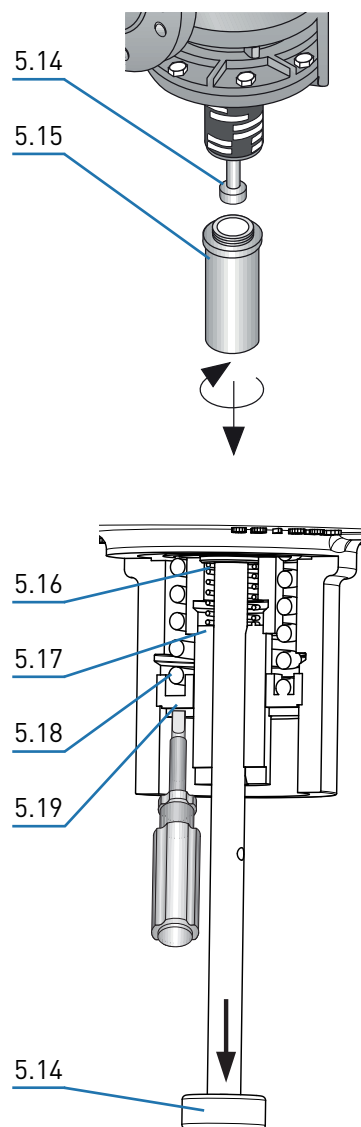

### Changing the control range

Switching to the control range of a different setpoint spring can be done for the SSV while the device is pressurised.

- Remove the sealing cap (item 5.15) and screw off the pull knob (item 5.14) for changing the spring of the underpressure shut-off device (item 5.16).
- Screw off the corresponding setting screw (items 5.17 / 5.19) for the upper or lower trigger level.
- Pull out the spring (item 5.16 / 5.18) and replace it with one that fits.
- Screw in the setting screw (item 5.17 / 5.19) again and fasten the pull knob (item 5.14) on the spindle again.
- Set the desired setpoint and screw on the sealing cap (item 5.15).

The SSV closes if the overpressure setpoint spring (upper trigger level) is removed from a pressurised system.

**Note**

## 5.5 Decommissioning

For decommissioning, please refer to the documents listed under item 1 "General Information" and the system operator's work instruction.

### Procedure

- Slowly close the outlet shut-off valve (item 5.13) or
- Close the ball valves upstream of the valves and fittings (item 5.01).
- Depressurise the system (item 5.11).
- Close venting ball valve (item 5.11).

## 6 Maintenance

### 6.1 Maintenance Plan

The following sections describe the maintenance work required for optimised and trouble-free operation of the device. If increased wear is detected during regular inspections, the required maintenance intervals must be shortened in accordance with the actual wear.

For any questions on maintenance work and intervals, please contact the manufacturer.

The intervals for monitoring and maintenance work are strongly dependent on the operating situation and the condition of the gas. This is why no fixed intervals can be given. For Germany, it is recommended to observe initially the maintenance periods according to the data given in DVGW Code of Practice G 495. For each system, this must be followed by determining the maintenance interval independently on a medium-term basis.

During maintenance work, the components must be cleaned and subjected to a thorough visual inspection. This is also necessary if irregularities in the operating behaviour have been detected during operation or during functional tests. The check must cover the diaphragms and sealings in particular.

Damaged parts and O-rings dismantled during dismantling must be replaced with new ones.

The item numbers mentioned in chapter 6.2 (Maintenance Procedure) correspond to those listed in the spare parts drawings and spare parts lists.

It is recommended to stock the parts listed in chapter 9.2 on page 18 for maintenance work.

Interval	Maintenance activities	Personnel
When required	Replacing O-rings	Qualified person
	Replacing diaphragms	
	Replacing the valve plate	
	Replacing sealing rings for the connections of the breather lines and measuring lines	

### 6.2 Maintenance Procedure

The maintenance procedure is described in detail step-by-step in our video tutorial and our pictorial descriptions. Instructions for our products can be found in the download area of our website. Should you have any problems, please feel free to contact us directly.

If components have been removed, make sure they are mounted correctly, reinstall all fastening elements and observe the screw tightening torques.

**NOTICE**



Prior to recommissioning, observe the following:

- Make sure that all maintenance work has been carried out and completed in accordance with the data and information given in these instructions.
- Make sure that no unauthorised persons stay in the danger zone.
- Make sure that all covers and safety devices have been installed and are working properly.

**DANGER**



For recommissioning, please refer to the relevant manufacturer's documentation of the gas pressure regulator installed in the system or chapter 1 and 5.4 as well as the work instructions of the system operator, and the other safety regulations for the system in which the regulator is installed.

To guarantee smooth operation, we recommend always keeping a maintenance set in reserve.

**Note**

### 6.3 Table of Screw Tightening Torques $M_A$

Item no.	S100 / 025 S100 / 040 S100 / 065	S100 / 050 S100 / 080 S100 / 100 S100 / 125	S100 / 150 S100 / 200
53	M8 / 18 Nm	M10 / 36 Nm	M12 / 62 Nm
54	M6 / 8 Nm	M6 / 8 Nm	M8 / 18 Nm
56	M8 / 18 Nm	M10 / 36 Nm	M12 / 62 Nm

### 6.4 Lubricants Table

Components (apply a thin layer)	Lubricants
All O-rings	Syntheso Proba 270
All fastening and locking screws	Anti Seize AS 450
Balls	Unisilikon TK 44N2

### 6.5 Screw Retention

Components (apply a thin layer)	Retention agent
Stud bolts	Loctite-648
Threaded pins	AN 320-21 Weiconlock

## 7 Replacement and Disposal

After the device has reached the end of its useful life, it must be dismantled and disposed of in an environmentally compatible manner.

During dismantling, components that may present a risk of injury by contamination, depending on the medium, are removed. Depending on the processed medium, the components must be properly decontaminated. Components capable of diffusion (diaphragm, O-ring, etc.) may have to be taken to a special disposal unit, depending on the material used. If no return or disposal agreement has been reached, dismantled components should be recycled:

- Metals should be scrapped
- The remaining components should be disposed of after sorting according to material.

**For technical information, please contact our customer service:**

MEDENUS Gas-Druckregeltechnik GmbH  
Saßmicker Hammer 40  
D-57462 Olpe

Phone +49 (0) 2761 / 82788-0  
Fax +49 (0) 2761 / 82788-9

E-Mail [info@medenus.de](mailto:info@medenus.de)  
Internet [www.medenus.de](http://www.medenus.de)

In addition, we are always interested in information and experience resulting from the application and which can be valuable for improving our products.

**NOTICE**



## 8 Troubleshooting

Description of the error	Possible cause	Elimination
No internal tightness in closed position	Actuator dirty or damaged	Check valve seat and valve plate (seal) for damage and dirt
	Pressure compensation ball valve dirty or sealing elements damaged	Check ball valve and replace if required
SSV cannot be opened	No pressure compensation at actuator	Perform pressure compensation via the SSV by pulling at the pull knob *
SSV cannot be engaged	Difference between response pressure and operating pressure or between upper and lower response pressure is too small	Correct response pressure settings consider required re-engagement differential (see product overview on p. 100)
	only in case of underpressure switching: Diaphragm in the control device defective or incorrectly installed	Check diaphragm and replace it, if necessary
	Pressure at the measuring point too high or low (only with underpressure switching)	Lower or increase pressure at measuring point to operating value (GPR setpoint value)
	Sluggishness of the trigger mechanism due to dirt / wear	Service switching device and replace if worn-out mechanically
Permissible response pressure group is exceeded Irregularities in response behaviour	Difference between response pressure and operating pressure or between upper and lower response pressure is too small	Correct response pressure settings consider required re-engagement differential (see product overview on p. 100) **
	Diaphragm in the control device incorrectly installed	Check diaphragm for irregular tension
	Sluggishness of the trigger mechanism due to dirt / wear	Service switching device and replace if worn-out mechanically
Gas escapes through breather line	Diaphragm clamping has become loose Diaphragm is damaged or has been mounted incorrectly O-ring sealing (item 7) dirty or damaged	Check diaphragm for fastening, damage and correct fit Check O-ring and replace it, if necessary

\*) The pull knob must be pulled for the entire duration until pressure compensation is complete. Check whether the shut-off valve downstream of the regulator is closed.

\*\*) Differential pressures between GPR, SSV and system SRV must reflect the response and closing pressure groups as well as the re-engagement differentials of the devices in order to avoid any unintended SRV switching.

**Note**



## 9 Spare Parts

### 9.1 Spare Part Drawing of Safety Shut-Off Valve SSV

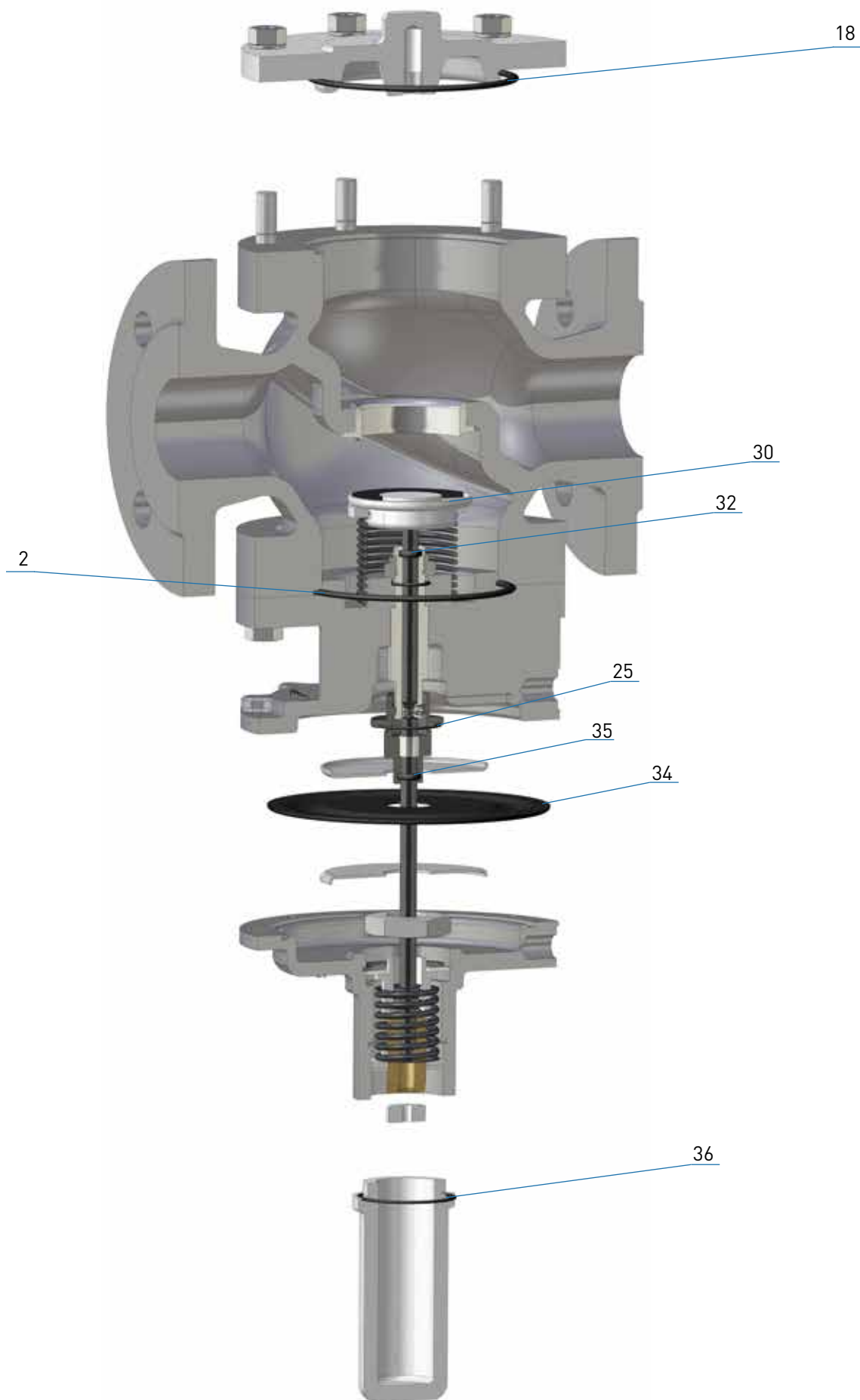

## 9.2 Parts for Maintenance Work

### Valve Plate SSV / Diaphragm SSV

Item no.	Name	Number	Exception	S100 / 025 S100 / 040	S100 / 050 S100 / 080 S100 / 100 S100 / 125	S100 / 065	S100 / 150	S100 / 200
30	Valve plate	1		<b>VT-201</b>	<b>VT-206</b>	<b>VT-204</b>	<b>VT-208</b>	<b>VT-210</b>
			DN 050		<b>VT-204</b>			
34	Diaphragm	1		<b>M-201</b>	<b>M-201</b>	<b>M-201</b>	<b>M-202</b>	<b>M-202</b>

### O-Rings and Sealing Rings

Item no.	Name	Quantity pcs.	S100 / 025 S100 / 040	S100 / 050 S100 / 080 S100 / 100 S100 / 125	S100 / 065	S100 / 150	S100 / 200
2	O-ring	1	O-014	O-036	O-018	O-045	O-046
18	O-ring	1	O-014	O-036	O-018	O-045	O-045
25	O-ring	1	O-001	O-001	O-001		
32	O-ring	1	O-007	O-007	O-007	O-009	O-009
35	O-ring	1	O-007	O-007	O-007	O-009	O-009
36	O-ring	1	O-013	O-013	O-013	O-014	O-014
<b>O-ring set order number:</b>			<b>OS-031</b>	<b>OS-032</b>	<b>OS-033</b>	<b>OS-034</b>	<b>OS-035</b>

### Example:

Safety shut-off valve:: S100 / 100 / MD-R

Spare parts according to tables in 9.2

Valve plate SSV: **VT-206**  
 Diaphragm SSV: **M-201**  
 O-ring and sealing ring set: **OS-032**

**Info:** The allocation of individual parts is done according to the item no. in the tables in 9.2, conforming to the spare parts drawings in 9.1.

# 10 Notes

Dotted lines for writing notes.

## Declaration of Conformity

(Summary)

Manufacturer: Medenus Gas-Druckregeltechnik GmbH

Address: Saßmicker Hammer 40  
D-57462 Olpe-Saßmicke

herewith declares that the product:

**S 100** Safety shut-off valve

has been subjected to an EC type examination and conforms to the basic requirements of the directives GAD 2009/142/EC EC Gas Appliances Directive in the respective current version. For devices that additionally carry the CE mark, an EC-type-examination certificate has been issued according to:

EU/97/23/EC A III B EC Pressure Equipment Directive  
**Test reports:** CE-0085 / AZ 12/225/4303/115 (S100)  
CE-0085 / AZ 12/225a/4303/115

The EC type-examination is based on the harmonised European Standards and/or national standards:  
DIN 14382 (2009-07-01)

Marking (PIN) according to Gas Appliances Directive

**CE-0085AQ0880 model S 100**

Marking according to Pressure Equipment Directive



The quality assurance system (module D) is monitored by the DVGW.

Olpe-Saßmicke,  
2016-09-30

A handwritten signature in blue ink, appearing to read 'Martin Clemens', is written over a horizontal line.

Martin Clemens  
Managing Director

In the download area of our homepage, this document is available in different languages. You can use the following QR codes and links to go directly to this document in your language.



**German:**

[http://medenus.de/files/upload/  
downloads/S100/  
BWA\\_S100\\_de.pdf](http://medenus.de/files/upload/downloads/S100/BWA_S100_de.pdf)



**MEDENUS** Gas-Druckregeltechnik GmbH

Fon +49 (0)2761 82788-0

Fax +49 (0)2761 82788-9

Saßmicker Hammer 40 / D-57462 Olpe

[info@medenus.de](mailto:info@medenus.de)

[www.medenus.de](http://www.medenus.de)

CE

EN