

MEDENUS

Gas Pressure Regulation



Gas pressure regulator RS 250 / RS 251



Operating and Maintenance Instructions

EN

Table of Contents

1 General Information	4
1.1 Warranty and Liability	4
1.2 Symbols, Notes	5
1.3 Terms, Abbreviations	5
2 Safety Instructions	6
2.1 Hazards of Handling the Device	6
2.2 Personnel Requirements	6
2.3 Country-Specific Requirements	6
2.4 Handover of the Operating and Maintenance Instructions	6
2.5 Safety in Operation	7
2.6 What To Do in Case of Danger	7
3 Responsibility of the Operator	7
4 Transport, Storage and Packaging	8
4.1 Transport	8
4.2 Storage	8
4.3 Packaging	8
5 Mounting and Commissioning	9
5.1 Safety Instructions and Preparation	9
5.2 Mounting	10
5.3 Leakage Test (Test for External Leakage)	11
5.4 Initial Commissioning / Recommissioning	12
5.5 Decommissioning	14
6 Maintenance	14
6.1 Maintenance Plan	14
6.2 Maintenance Procedure	15
6.3 Table of Screw Tightening Torques M_A	16
6.4 Lubricants Table	16
6.5 Screw Retention	16
7 Troubleshooting	17
7.1 Gas Pressure Regulator	17
7.2 Safety Shut-Off Valve	18
8 Replacement and Disposal	19
9 Spare Parts	20
9.1 Spare Parts Drawing RS 250 / RS 251 DN 25 - DN200	20
9.2 Optional Spare Parts Drawing	21
9.3 Parts for Maintenance Work	22
Main diaphragm and O-ring	22
Intermediate Diaphragm	22
Valve plate	22
Valve Plate SSV / Diaphragm SSV	23
O-Ring and Sealing Ring Sets	23
Safety diaphragm	24
10 Notes	25
11 Declaration of Conformity	26

1 General Information

The personnel entrusted with installation, operation or maintenance of the gas pressure regulator must have completely read and understood beforehand the following documents:

- **Gas Pressure Regulator RS 250 / RS 251 Product Information**
The product information contains technical data, dimensions and a description of the design and the mode of operation.
- **Gas Pressure Regulator RS 250 / RS 251 Operating and Maintenance Instructions**
This document allows safe and efficient handling of the device and contains information on assembly, commissioning, maintenance, troubleshooting and repair according to regulations.
It is an integral part of the scope of delivery of the device, must be kept in close proximity of the device and must be readily accessible to personnel at any time.
The basic requirement of safe operation is compliance with all safety instructions and guidelines specified in these instructions. Accordingly, the information and instructions must be observed when working on the device or on the gas line. In addition, the local occupational safety regulations and the general safety regulations for the application range of the device shall apply.
The figures in these instructions are provided for basic understanding and may differ from the actual design. The contents in these instructions are protected by copyright. They may be used as part of operating the device. Any other use and / or reproduction is not permitted without prior authorization by the MEDENUS Gas-Druckregeltechnik GmbH.

1.1 Warranty and Liability

Claims under warranty or liability for personal injury and material damage are generally void, **if one or several of the following conditions are not observed:**

- Work on the device during the warranty period may only be performed in consultation with the manufacturer
- Designated use of the device in accordance with the established conditions of use
- Proper installation, commissioning, operation and maintenance of the device
- Operation of the device with properly installed and functioning safety devices only
- Operating and maintenance instructions of the device or of the system
- Observance of the maintenance instructions
- Properly performed repairs
- Supply lines without defects
- The use of original MEDENUS® spare parts and lubricants listed in these instructions or
- Force majeure

It is generally prohibited

- to perform constructive modifications on the device
- to keep using the device despite the detection of a defect

1.2 Symbols, Notes

The instructions contain safety instructions marked with symbols to indicate possible consequences in case of non-observance:

This combination of symbol and signal word indicates a potentially hazardous situation which may result in light injuries, damage to the device, the breakdown of the system, and material or environmental damage if not avoided.



NOTICE

This combination of symbol and signal word indicates an imminent hazardous situation, resulting in death or serious injuries if not avoided.



DANGER

This signal word highlights useful tips, recommendations and information for efficient and trouble-free operation.

Note

1.3 Terms, Abbreviations

Terms and abbreviations are explained below:

ATC	Acceptance test certificate	p_d	Outlet pressure	MOP	Maximum operating pressure in a system
DN	Nominal width	p_{ds}	Setpoint of the outlet pressure		
GPR	Gas pressure regulator	SSV	Safety shut-off valve		
HDS	High-pressure screw spindle	SRV	Safety relief valve		
M_A	Screw tightening torque				

2 Safety Instructions

National accident prevention regulations and the system operator's safety regulations are not superseded by these operating and maintenance instructions and must be taken into consideration with priority (in Germany, see, among others, DVGW Code of Practice G 600, G 459/II, G 491 and G 495).

When performing work on the device, the current general and specific safety regulations must be observed.

The application limits of the device with respect to the medium, operating pressure and operating temperature can be found on the type plate affixed to the device or on the acceptance test certificate.

Using the device under different operating conditions must be agreed upon in consultation with MEDENUS Gas-Druckregeltechnik GmbH.

The mechanical components of the device do not have any potential ignition sources of their own nor any hot surfaces and are thus not within the scope of 2014/34/EU (ATEX). The electronic accessories used comply with the ATEX requirements.

2.1 Hazards of Handling the Device

MEDENUS® devices conform with current standards and directives, the recognized technical rules and the recognized safety rules.

However, improper use can result in hazards to the user or to third parties. This can also result in damage to the device or to the system.

This is why the device may only be used:

- in accordance with its designated use
- in perfect condition
- while observing the notes given in these operating and maintenance instructions, and inspection and maintenance regulations, which apply to the functioning and safety of the overall system.

Malfunctions or faults must be eliminated immediately.

2.2 Personnel Requirements

The device may only be mounted by qualified personnel.

Only authorised personnel in possession of the required qualification is allowed to perform settings or repairs on the device.

2.3 Country-Specific Requirements

The rules and regulations applicable at the place of use with respect to

- gas lines, installation of the gas system,
- gas supply,
- work on the gas system,
- accident prevention must be observed and complied with.

2.4 Handover of the Operating and Maintenance Instructions

The supplier of the system shall hand over these operating and maintenance instructions to the operator of the system no later than during commissioning and training of the operating personnel with the reminder to carefully store these instructions.

2.5 Safety in Operation

The device may only be used when all protective devices on the device or in the system are fully functional.

The device must be inspected by a representative of the manufacturer or by a qualified person for externally visible damage and for proper functioning at least once a year.

A more frequent inspection may become necessary, depending on the system conditions.

2.6 What To Do in Case of Danger

Information on what is to be done in case of danger and in case of accidents can be found in the respective operator's or specialist companies' work instructions.

3 Responsibility of the Operator

Operator An operator is a person who operates the device himself for commercial or economic purposes or hands it over to a third party for use / application and is legally responsible for the safety of the user, personnel or third parties.

Operator's obligations The device is used in the industrial sector. Accordingly, the operator of the device is subject to the legal obligations concerning occupational safety. In addition to the safety instructions contained in these instructions, the established maintenance intervals must be observed, taking into account the respective national standard (alarm and hazard prevention plan).

In particular, the following applies:

- The operator is obliged to perform work on MEDENUS® devices during the warranty period only after consultation with the manufacturer. Otherwise the claims under warranty will become void.
- The operator must obtain information on the current occupational safety regulations and determine additional hazards resulting from the special work conditions at the place of use of the device in a risk assessment. The operator must implement them in the form of operating manuals for operating the device.
- During the entire time of use of the device, the operator must check whether the operating manuals drawn up by him conform to the current state of the regulations and, if necessary, adapt them.
- The operator must clearly regulate and define the responsibilities for installation, operation, troubleshooting, maintenance and cleaning.
- The operator must ensure that all persons handling the device have read and understood these instructions. In addition to that, he must train the personnel at regular intervals and inform it about the dangers.
- The operator must make available to the personnel the required protective equipment and oblige them to wear the required protective equipment.
- Moreover, the operator is responsible for the device always being in technically perfect condition.

Therefore, the following applies:

- The operator must make sure that the maintenance intervals described in these instructions are observed.
- The operator must have all safety devices checked regularly for functioning and completeness.

4 Transport, Storage and Packaging

4.1 Transport

Note

The device is delivered with flange protective caps. They must be removed prior to installation. Make sure that the device is transported horizontally using suitable lifting gear. The device must be handled carefully and secured against impact and shock. In case of transport damage, we will require the following information from the type plate affixed to the device:

- Type of device
- Device model
- Year of construction / fabrication number

4.2 Storage

Equipment and spare parts must be stored under the following conditions:

- Do not store outdoors.
- Store in a dry and dust-free location.
- Store on a flat surface.
- Do not expose to aggressive media.
- Do not expose to ozone or ionising radiation.
- Do not store adjacent to direct heat sources.
- Avoid mechanical vibrations.
- Storage temperature: 0 to 25°C.
- Relative humidity: < 55 %.

Spare parts:

- Components susceptible to corrosion must be provided with a suitable preservative.
- Do not store O-rings and seals for more than 7 years even if stored properly.
- Spare parts must be stored in their original packaging until use.

Storage period for devices:

- Storage of the device for up to one year:
Store the gas pressure regulator in its original packaging and original condition at the time of supply. All protective caps of the device must remain mounted.
- Storage of the device for more than 1 year (e.g. as a spare device):
Store the device in its original packaging and original condition at the time of supply and check it for damage once a year. Check the housing surface for dirt, damage and corrosion. If necessary, clean all external parts. After 7 years, all O-rings and seals must be replaced.

4.3 Packaging

- The individual packaged items have been packaged in view of the transport conditions to be expected.
- The symbols on the packaging must be observed during transport and storage.
- Only environmentally-friendly materials have been used for packaging.
- The packaging is designed for protecting the individual components from transport damage, corrosion and other damage until mounting. This is why the packaging must not be destroyed and only be removed just prior to mounting.

5 Mounting and Commissioning

5.1 Safety Instructions and Preparation

Prior to starting work on pressurised components:

- Close all connections to the gas line.
- Depressurise all pressurised components. Also discharge residual energies.
- Defective components that are subject to pressure in operation must be replaced immediately by a suitable qualified person.

DANGER



Prior to starting work, ensure sufficient clearance for mounting.

Before installing the device, check whether the performance data (type plate) and the scope of delivery coincide with the order or the system data, i.e., make sure that the provided devices are suitable for their intended purpose. In particular, the inlet pressure of the system must be lower than the maximum allowable pressure of the device.

Note

A direct contact of gas valves and fittings, i.e., the control system, with hardening masonry, concrete walls or floors is not allowed. Provide suitable supports, working materials and protective equipment. Take into account the minimum clearances for maintenance as stated in the product information. Before installing the device in the pipeline, check whether a shut-off device that interrupts the gas flow supply to the device has been mounted upstream and downstream of the device to be installed.

Note

Prior to commissioning, make sure that all installation work has been carried out and completed in accordance with the data and information given in these instructions and that no unauthorised persons stay in the danger zone.

DANGER



5.2 Mounting

- Remove packaging and protection from the connection flange surfaces.
- Install the device without twisting the pipeline. Tighten screws crosswise.
Make sure to observe the direction of flow, i.e. the arrow on the housing must point in the direction of flow.
- In all installation positions other than horizontal, MEDENUS Gas-Druckregeltechnik GmbH must be consulted.
- The tightening torques of the flange connections and additional information is available in the DVGW GAS information issue no. 19 (Flanged Connections in Gas Installations).

Note

Note

Note

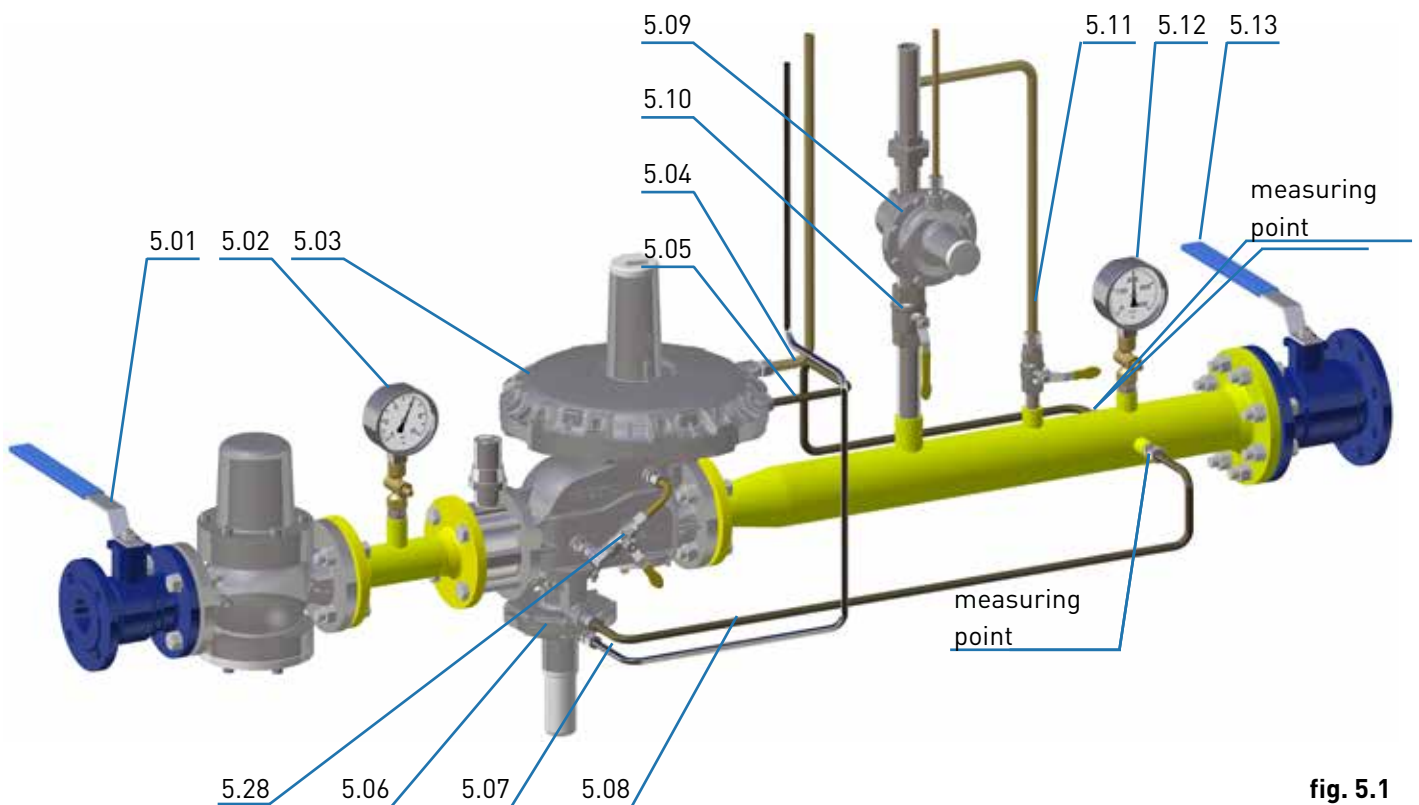

fig. 5.1

- A separate installation of the SSV breather line (item 5.07) is recommended.
- All breather lines (items 5.04 / 5.07) must be vented to the outside atmosphere.
- Breather lines (items 5.04 / 5.07) may not be required if breather valves or safety diaphragms are being used.
- The measuring lines (items 5.05 / 5.08) must be connected in a pipeline section with a steady flow. There must be no installations that cause flow interference such as shutters, expansions, manifolds, junctions, isolation valves etc. directly upstream and downstream of the measurement point.
- The maximum flow rate at the measuring point must not exceed 25 m/s, depending on the system conditions.
- In certain system circuits, such as gas control systems for gas motors and in gas burners, higher flow rates than 25 m/s are also possible. Please contact us.
- The measuring line must be connected to the pipeline separately, laterally or at the top for each device (1 gas pressure regulator (item 5.03); 1 integrated SSV (item 5.06)).
- The SSV measuring line (Pos. 5.08) must always be connected to the measuring point in front of the first outlet-side shut-off valve (item 5.13).

5.3 Leakage Test (Test for External Leakage)

The devices are subjected to a strength and leakage test ex works at MEDENUS Gas-Druckregeltechnik GmbH.

The leakage test in the fully assembled system must be performed prior to commissioning and following maintenance work.

For the external leakage test in the fully assembled system, the following applies:

For Germany:

According to DVGW Code of Practice G 491, the fully assembled system must be subjected to a leakage test with air or an inert gas at the installation site, using 1.1 times the maximum operating pressure of the system (MOP).

An exception is the room between the actuator installed in the gas pressure regulator and the first shut-off valve on the outlet side. This room must be checked using the a test pressure corresponding to the maximum permissible pressure in the system in case of a malfunction (1.1 MOP_d). In this test, all detachable connections must be checked using a foaming agent.

In direct-acting devices (without power supply), the outlet pressure acting on the actuator (limited by the SSV) should not be more than 0.5 bar above the set setpoint. This should be taken into account when specifying the response pressure of the upstream SSVs.

Note

Recommended upper response pressures:

- $P_d \leq 100 \text{ mbar}$ $P_{dso} = P_d + 50 \text{ mbar}$
- $P_d > 100 - 200 \text{ mbar}$ $P_{dso} = P_d + 100 \text{ mbar}$
- $P_d > 200 - 1000 \text{ mbar}$ $P_{dso} = P_d \times 1.5$
- $P_d > 1000 \text{ mbar}$ $P_{dso} = P_d + 500 \text{ mbar}$

For other countries:

The relevant national and international standards shall apply.

Procedure

- Close the ball valves upstream of the valves and fittings (item 5.01).
- Close the downstream shut-off devices (item 5.13) (ball valves, solenoid or pneumatic valve).
- Depressurise the system (item 5.11).
- If there is a SRV (safety relief valve) in the controlled section and the test pressure is higher than the relief pressure of the SRV (item 5.09), the line upstream of the SRV (item 5.10) must be closed.
- Raise the test pressure always slowly and steadily.

While doing so, you must ensure:

Pressure in outlet chamber (item 5.12) \leq Pressure in inlet chamber (item 5.02)

Pressure build-up always from the inlet side (inlet chamber)

Pressure reduction always from the outlet side (outlet chamber)

- After leakage test:
Open the ball valve in the SRV line (item 5.10) again.

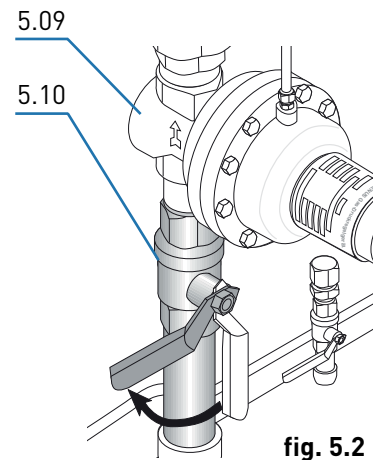

fig. 5.2

Note

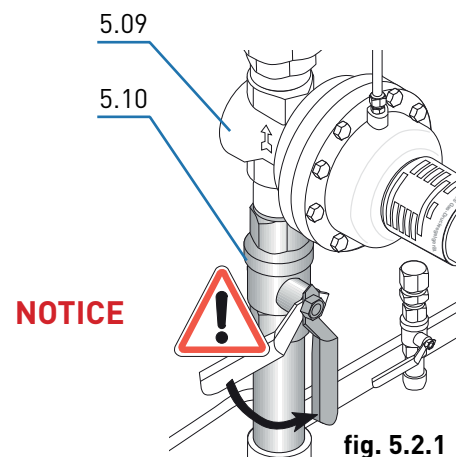

fig. 5.2.1

5.4 Initial Commissioning / Recommissioning

Initial commissioning of the system components shall be carried out by the operator. For commissioning, please refer to the documents listed under item 1 "General Information" and the system operator's work instruction.

The devices delivered by MEDENUS Gas-Druckregeltechnik GmbH are factory-set to the operating data specified by the customer. This data is listed on the Acceptance Test Certificate (ATC)* and the type plate.

Note Prior to commissioning of the system, a functional test must be performed on the gas pressure regulator (GPR), if applicable, and the safety shut-off and safety relief valves.

Procedure (fig. 5.1)

- Close the ball valves upstream of the valves and fittings (item 5.01).
- Close the downstream shut-off devices (item 5.13) (ball valves, solenoid or pneumatic valve).
- Depressurise the system (item 5.11).
- Close venting ball valve (item 5.11).
- Slowly open ball valve upstream of the valves and fittings (item 5.01).

Note If the inlet shut-off device is equipped with a bypass, the latter must be slowly opened for pressure compensation as step 1. This is followed by slowly opening the inlet shut-off valve. The same is true of the outlet shut-off valve.

- Check the inner leakage of the SSV (item 5.06) by reading the pressure gauge installed downstream of the GPR (item 5.12).
- Unscrew the sealing cap (item 5.15) of the safety shut-off valve (SSV).
- Perform pressure compensation via the SSV by pulling at the pull knob (item 5.14) and allowing the SSV to engage. In GPR with bypass ball valve (item 5.28), open the ball valve (item 5.28) while pulling the pull knob (item 5.14) until the SSV engages to perform pressure compensation.
- A closing pressure corresponding to the set value is established on the GPR.

Note An SSV with underpressure shut-off can only be engaged if the pressure at the measuring point exceeds the set value by at least the re-engagement differential.

- Testing the response pressure of the SSV by slowly increasing or decreasing the output pressure to response pressure.
- It may be necessary to correct the setpoint values of the response pressures. This is done by turning the SSV setpoint setting screws (items 5.17 / 5.19) to the right (pressure increase) or left (pressure decrease) in order to increase/decrease the setpoint value.

Note The inner setting screw (item 5.17) sets the underpressure shut-off level (lower trigger level) and the outer setting screw (item 5.19) sets the upper trigger level.

- Perform pressure compensation via the SSV again by pulling the pull knob (item 5.14) and allowing the SSV to engage.

*) Acceptance Test Certificate (ATC) available optionally

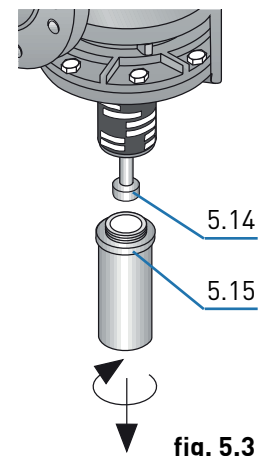

fig. 5.3

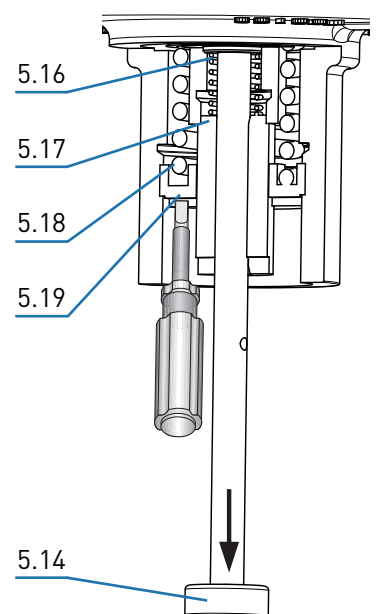

fig. 5.4

- For the functional test of the GPR, let gas flow via the discharge line (venting) (item 5.11) to the outside atmosphere and read the set regulating pressure on the outlet pressure gauge (item 5.12).
- It may be necessary to correct the setpoint of the outlet pressure once again. This is done by turning the GPR setpoint setting screw (item 5.22) to the right or left, in order to increase and decrease the setpoint, respectively, after removal of the GPR sealing cap (item 5.21).
- After closing the discharge line (item 5.11), a constant closing pressure within the closing pressure class can be read on the outlet pressure gauge (item 5.12).
- Slowly open the shut-off valve (item 5.13), close the discharge line (item 5.11) and read the set regulating pressure on the outlet pressure gauge (item 5.12).
- It may be necessary to correct the setpoint of the outlet pressure once again.
- Screw on the sealing cap (item 5.15) of the safety shut-off valve (SSV) again.
- Screw on the GPR sealing cap (item 5.21) again.

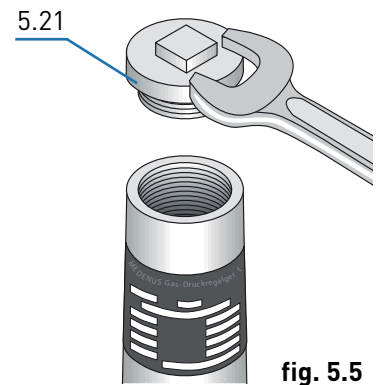

fig. 5.5

Changing the control range

Switching to the control range of a different setpoint spring can be done for the SSV as well as for the GPR while the device is pressurised.

Gas pressure regulator

- Take off the sealing cap (item 5.21) and unscrew the setting screw (item 5.22).
- Pull out the spring plate (item 5.24) with ball (item 5.23) and spring (item 5.25) and replace the spring with one that fits.
- Screw in the spring plate (item 5.24), the ball (item 5.23) and the setting screw (item 5.22) again.
- Set the desired setpoint and screw on the sealing cap (item 5.21) again.

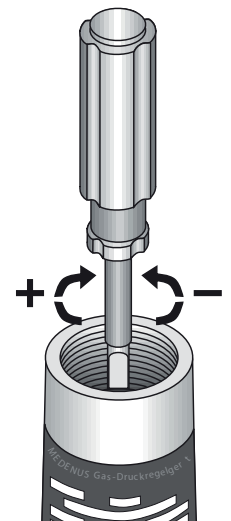

fig. 5.6

Safety shut-off valve

- Remove the sealing cap (item 5.15) and screw off the pull knob (item 5.14) for changing the spring of the underpressure shut-off device (item 5.16).
- Screw off the corresponding setting screw (items 5.17 / 5.19) for the upper or lower trigger level.
- Pull out the spring (item 5.16 / 5.18) and replace it with one that fits.
- Screw in the setting screw (item 5.17 / 5.19) again and fasten the pull knob (item 5.14) on the spindle again.
- Set the desired setpoint and screw on the sealing cap (item 5.15).

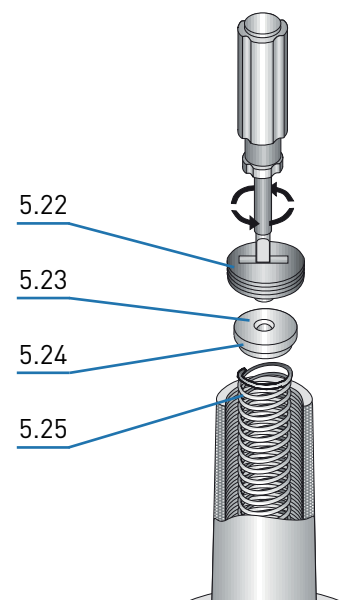

fig. 5.7

Note

The SSV closes if the overpressure setpoint spring (upper trigger level) is removed from a pressurised system.

5.5 Decommissioning

For decommissioning, please refer to the documents listed under item 1 "General Information" and the system operator's work instruction.

Procedure (fig. 5.1)

- Slowly close the outlet shut-off valve (item 5.13) or
- Close the ball valves upstream of the valves and fittings (item 5.01).
- Depressurise the system (item 5.11).
- Close venting ball valve (item 5.11).

6 Maintenance

6.1 Maintenance Plan

The following sections describe the maintenance work required for optimal and trouble-free operation of the device. If increased wear is detected during regular inspections, the required maintenance intervals must be shortened in accordance with the actual wear.

For any questions on maintenance work and intervals, please contact the manufacturer.

The intervals for monitoring and maintenance work are strongly dependent on the operating situation and the condition of the gas. This is why no fixed intervals can be given. For Germany, it is recommended to observe initially the maintenance periods according to the data given in DVGW Code of Practice G 495. For each system, this must be followed by determining the maintenance interval independently on a medium-term basis.

During maintenance work, the components must be cleaned and subjected to a thorough visual inspection. This is also necessary if irregularities in the operating behaviour have been detected during operation or during functional tests.

Damaged parts and O-rings dismantled during dismantling must be replaced with new ones.

The item numbers mentioned in chapter 6.2 (Maintenance Procedure) correspond to those listed in the spare parts drawings and spare parts lists.

It is recommended to stock the parts listed in chapter 9.3 for maintenance work.

Interval	Maintenance activities	Personnel
When required	Replacing O-rings	Qualified person
	Replacing diaphragms	
	Replacing the valve plate	
	Replacing sealing rings for the connections of the breather lines and measuring lines	

6.2 Maintenance Procedure

The maintenance procedure is described in detail step-by-step in our video tutorial and our pictorial descriptions. Instructions for our products can be found in the download area of our website. Should you have any problems, please feel free to contact us directly.

If components have been removed, make sure they are mounted correctly, reinstall all fastening elements and observe the screw tightening torques.

NOTICE



Prior to recommissioning, observe the following:

- Make sure that all maintenance work has been carried out and completed in accordance with the data and information given in these instructions.
- Make sure that no unauthorised persons stay in the danger zone.
- Make sure that all covers and safety devices have been installed and are working properly.

DANGER



For recommissioning, please refer to the relevant manufacturer's documentation of the gas pressure regulator installed in the system or chapter 1 and 5.4 as well as the work instructions of the system operator, and the other safety regulations for the system in which the regulator is installed.

To guarantee smooth operation, we recommend always keeping a maintenance set in reserve.

Note

6.3 Table of Screw Tightening Torques M_A

Item no.	Exception	RS 250 / 025 RS 250 / 050 RS 250 / 080 RS 250 / 100 RS 251 / 050	RS 250 / 150 RS 250 / 200 RS 251 / 080 RS 251 / 100
50		M8 / 18 Nm	M10 / 36 Nm
	RE 205	M10 / 36 Nm	
51		M8 / 18 Nm	M10 / 36 Nm
52		M8 / 18 Nm	M10 / 36 Nm
	DN 200		M12 / 62 Nm
53		M8 / 18 Nm	M10 / 32 Nm
	DN 200		M12 / 62 Nm
54		M6 / 8 Nm	M8 / 18 Nm

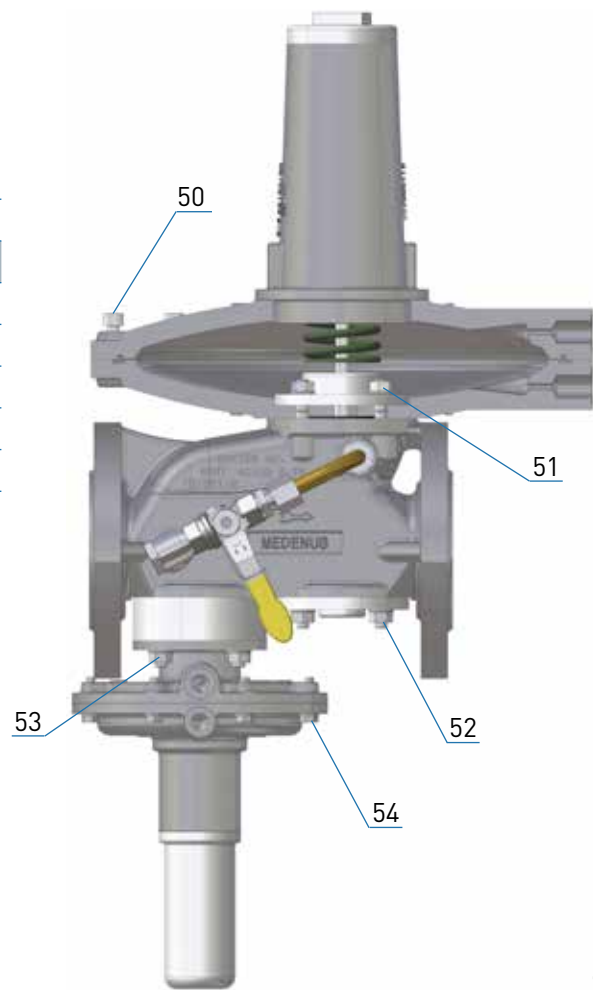

fig. 6.1

6.4 Lubricants Table

Components (apply a thin layer)	Lubricants
All O-rings	Syntheso Proba 270
All fastening and locking screws	Anti Seize AS 450
Balls	Unisilkon TK 44N2

6.5 Screw Retention

Components (apply a thin layer)	Adhesive and sealing agent
Stud bolts	Loctite-648

7 Troubleshooting

7.1 Gas Pressure Regulator

Description of the error	Possible cause	Elimination
Closing pressure too high No closing pressure	Actuator dirty or damaged	Check valve plate (seal) and valve seat for damage and dirt, replace valve plate, if necessary
	Static sealing elements defective	Replace O-rings
	Clamping of the compensating diaphragm has come off Compensating membrane is damaged or mounted incorrectly.	Check compensating diaphragm for fastening, damage, and correct fit, replace it, if necessary.
	Valve plate has become disconnected from the valve stem	Tighten nut under the valve plate
Unstable outlet pressure curve (vibrations, pulsation)	Device is working in the closing pressure range	Check regulator design
	Vibration resonance in the control system	Install restrictor plate in breather line Install baffle plate in measuring line Continue closing restrictor in measuring line by turning clockwise * Install a harder spring (setpoint spring of the next higher control range) Check setting of gas consumption devices Use of throttle valve RSD (optional accessory)
Control deviation too large	Unfavourable connection of the measuring line	Select a measuring point with steady flow, check measuring point
	Sluggishness of the device due to dirt	Subject device to maintenance
	Main diaphragm or compensating diaphragm defective or mounted incorrectly	Check diaphragm and replace if necessary
	Wrong regulator size selected Wrong setpoint spring selected Wrong control cone selection	Check controller design, setpoint spring / control cone and replace if necessary
	Inlet pressure supply is insufficient (pressure losses in the supply line too high)	Increase inlet pressure Check pipeline cross-section Check built-in filter
Inadmissible pressure peak Dynamic closing pressure too high	Damping of the device too high Control system too dynamic	Continue opening restrictor in measuring line by turning anticlockwise Remove restrictor plate from breather line Check breather lines and dimension them larger, if necessary. Replace breather valve with safety diaphragm or breather line
	Closing speed of downstream shut-off devices too high	Reduce closing speed of shut-off device
Noise	Gas velocity too high	Check regulator design
	Sluggishness of the device due to dirt / wear	Perform maintenance on actuator If worn-out mechanically, replace it, if necessary
Gas escapes through breather line	Fastening of the main diaphragm has come off Main diaphragm is damaged or has been mounted incorrectly	Check diaphragm for fastening, damage and correct fit
	Internal leakage gas SRV is set too low or is not tight	Correct settings of leakage gas SRV Check O-ring for damage and dirt, replace if necessary

*) Excessive damping limits the actuation speed.

**]) Normal flow noise does not constitute a fault. However, this noise can be reduced by installing a noise reduction device.

Note

7.2 Safety Shut-Off Valve

Description of the error	Possible cause	Elimination
No internal tightness in closed position	Actuator dirty or damaged	Check valve seat and valve plate (seal) for damage and dirt
	Pressure compensation valve (internal bypass) in the actuator dirty or sealing elements damaged	Check O-rings in the pressure compensation valve or at the SSV spindle and replace them, if necessary
SSV cannot be opened	No pressure compensation at actuator	Pressure compensation by opening the bypass ball valve (item 5.28)
SSV does not engage	Difference between response pressure and operating pressure or between upper and lower response pressure is too small	Correct response pressure settings consider required re-engagement differential (see RS 250 / 251 product overview)
	Only in case of underpressure switching: Diaphragm in the control device defective or incorrectly installed	Check diaphragm and replace it, if necessary
	Pressure at the measuring point too high or low (only with underpressure switching)	Lower or increase pressure at measuring point to operating value (GPR setpoint value)
	Sluggishness of the trigger mechanism due to dirt / wear	Service switching device and replace it, if worn-out mechanically
Permissible response pressure group is exceeded Irregularities in response behaviour	Difference between response pressure and operating pressure or between upper and lower response pressure is too small	Correct response pressure settings consider required re-engagement differential (see RS 250 / 251 product overview) *
	Diaphragm in the control device incorrectly installed	Check whether diaphragm is twisted
	Sluggishness of the trigger mechanism due to dirt / wear	Service switching device and replace it, if worn-out mechanically
Gas escapes through breather line	Diaphragm clamping has become loose Diaphragm is damaged or has been mounted incorrectly O-ring sealing (item 35) dirty or damaged	Check diaphragm for fastening, damage and correct fit Check O-ring and replace it, if necessary

*) The pressure differences between GPR, SSV and system SRV must consider the response and closing pressure groups as well as the re-engagement differentials of the devices in order to avoid any unintended SRV switching.

Note

8 Replacement and Disposal

After the device has reached the end of its useful life, it must be dismantled and disposed of in an environmentally compatible manner.

During dismantling, components that may present a risk of injury by contamination depending on the medium are removed. Depending on the processed medium, the components must be properly decontaminated. Components capable of diffusion (diaphragm, O-ring, etc.) may have to be taken to a special disposal unit, depending on the medium used. If no return or disposal agreement has been reached, dismantled components should be recycled:

NOTICE



- Metals should be scrapped
- The remaining components should be disposed of after sorting according to material.

For technical information, please contact our customer service:

MEDENUS Gas-Druckregeltechnik GmbH
Saßmicker Hammer 40
D-57462 Olpe

Phone +49 (0) 2761 / 82788-0
Fax +49 (0) 2761 / 82788-9

E-Mail info@medenus.de
Internet www.medenus.de

In addition, we are always interested in information and experience resulting from the application and which can be valuable for improving our products.

9 Spare Parts

9.1 Spare Parts Drawing RS 250 / RS 251 DN 25 - DN200

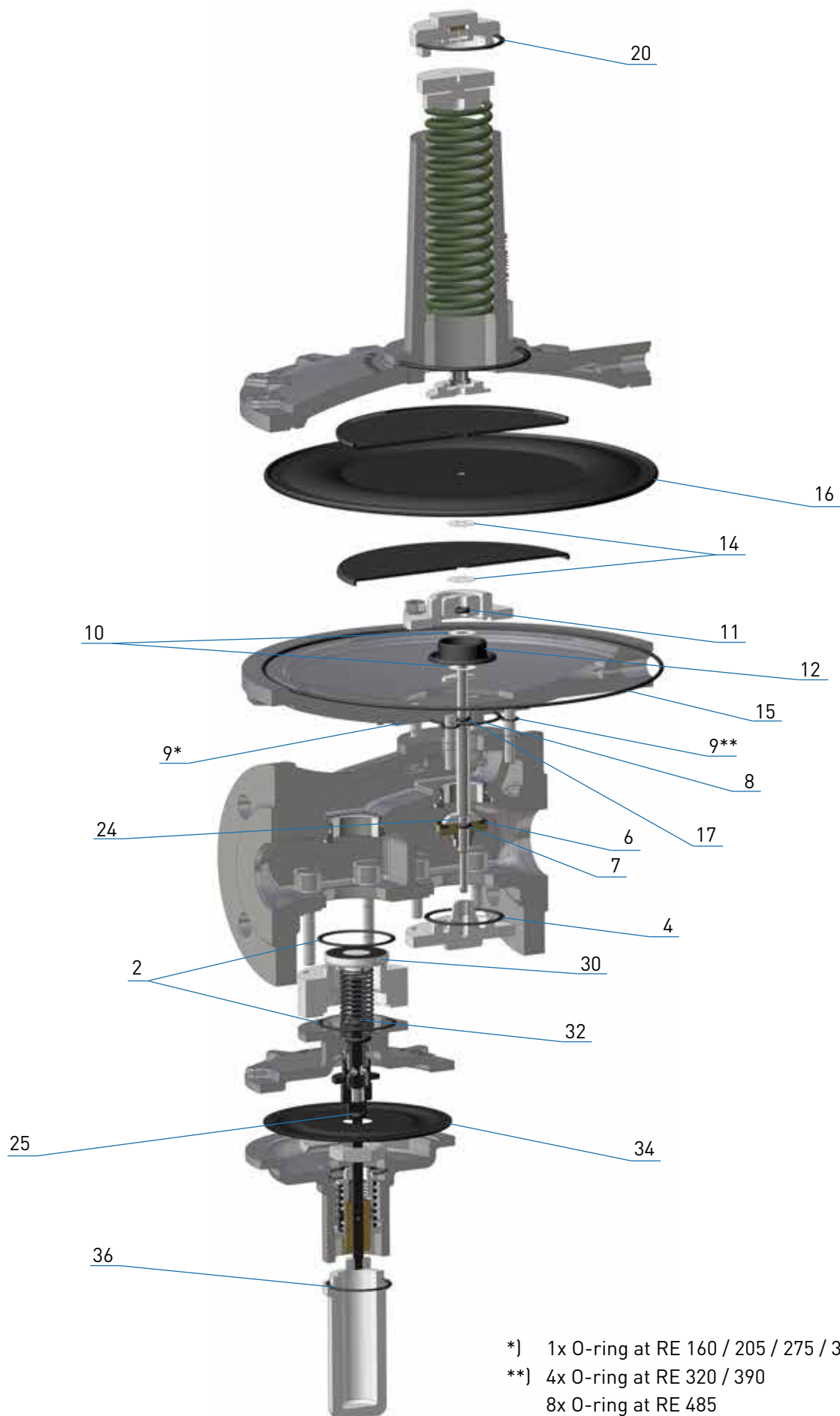
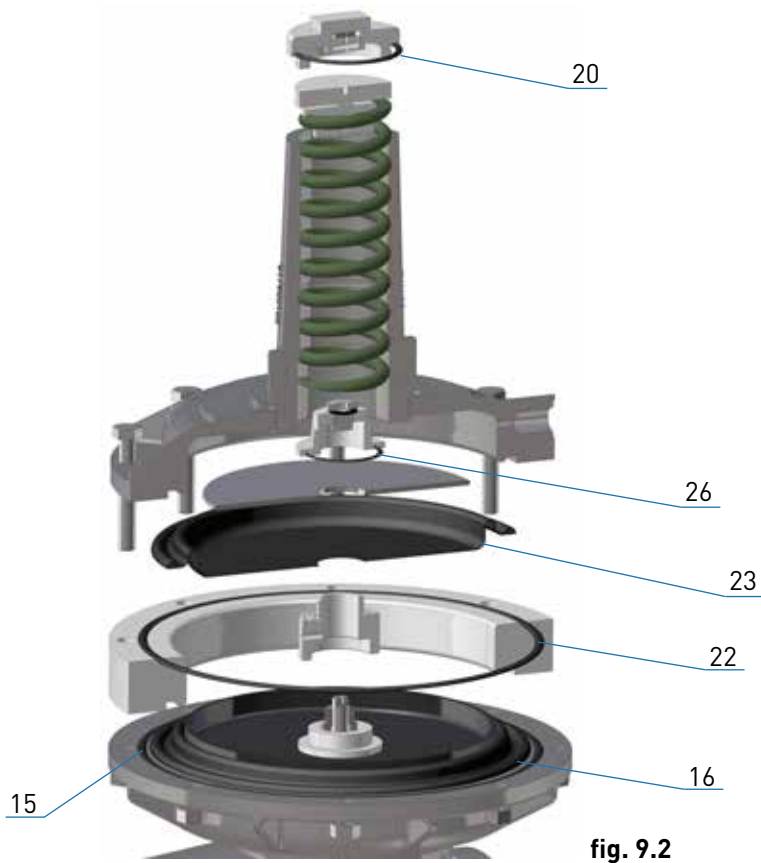
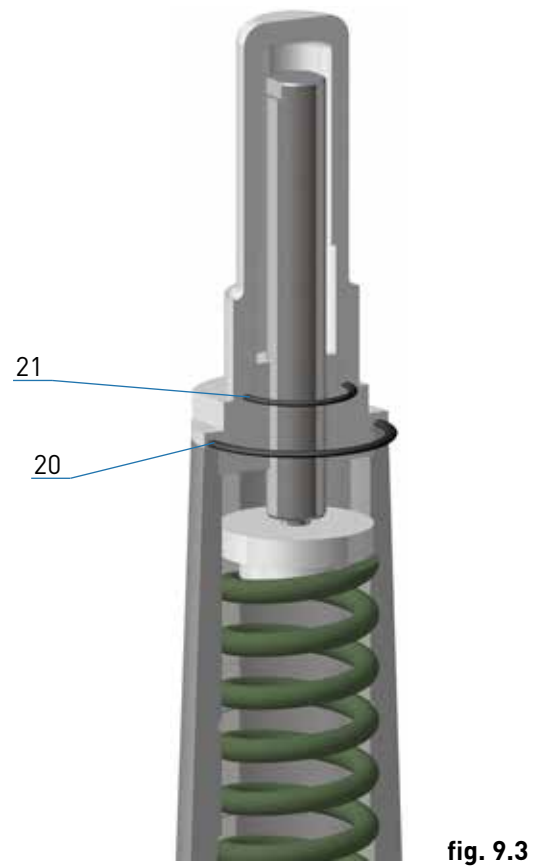

fig. 9.1

9.2 Optional Spare Parts Drawing



RS 250 / 251 shown with safety diaphragm



RS 250 / 251 shown with HDS high-pressure screw spindle

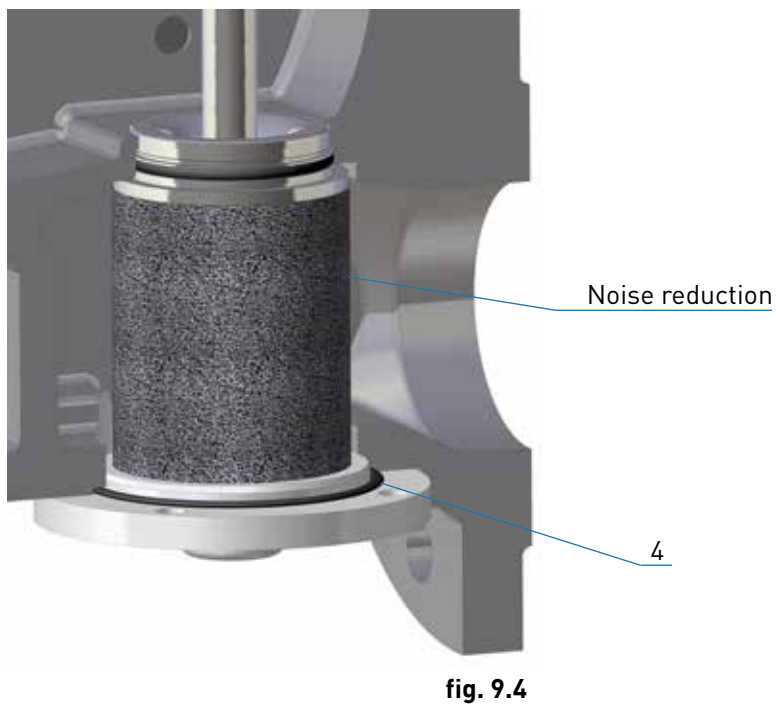

RS 250 / 251 shown with noise reduction

9.3 Parts for Maintenance Work

Main diaphragm and O-ring

Item no.	Name	Quantity pcs.	RS 250 / 025 RS 250 / 050			RS 250 / 080; RS 250 / 100; RS 251 / 050 RS 251 / 080; RS 250 / 150; RS 251 / 100; RS 250 / 200				
			RE 160	RE 205	RE 320	RE 205	RE 275	RE 385 / 390 MB	RE 385 / 390 GMB	RE 485
15	O-ring	1		O-029	O-033	O-029	O-041	O-042	O-042	O-043
16	Diaphragm	1	M-111	M-121	M-141	M-122	M-132	M-152	M-162	M-172
Main diaphragm set order number:			M-111	MS-121	MS-141	MS-122	MS-132	MS-152	MS-162	MS-172

Intermediate Diaphragm

Item no.	Name	Quantity pcs.	Valve	RS 250 / 025	RS 250 / 080	RS 251 / 080	RS 250 / 150	RS 250 / 200
				RS 250 / 050	RS 250 / 100		RS 251 / 100	
12	Diaphragm	1	17.5	M-001				
			27.5	M-002	M-003			
			32.5	M-004*	M-005			
			42.5		M-006	M-007	M-007	
			52.5		M-008**	M-009	M-009	
			65			M-010	M-010	
			85			M-011	M-011	
			95				M-012	M-012
			115					M-013

Valve plate

Item no.	Name	Quantity pcs.	Valve	RS 250 / 025	RS 250 / 080	RS 251 / 080	RS 250 / 150	RS 250 / 200
				RS 250 / 050	RS 250 / 100		RS 251 / 100	
6	Valve plate	1	17.5	VT-001				
			27.5	VT-002	VT-003			
			32.5	VT-004*	VT-005			
			42.5		VT-006	VT-006	VT-006	
			52.5		VT-007**	VT-007	VT-007	
			65			VT-008	VT-008	
			85			VT-009	VT-009	
			95				VT-010	VT-010
			115					VT-011

*) only in RS250 / 050

**) only in RS250 / 100 and RS251 / 050

Valve Plate SSV / Diaphragm SSV

Item no.	Name	Number	Exception	RS 250 / 025 RS 250 / 050	RS 250 / 080 RS 250 / 100 RS 251 / 050	RS 251 / 080	RS 250 / 150 RS 251 / 100	RS 250 / 200
30	Valve plate	1		VT-201	VT-202	VT-206	VT-208	VT-210
34	Diaphragm	1		M-201	M-201	M-201	M-202	M-202

O-Ring and Sealing Ring Sets

Item no.	Name	Quantity pcs.	Exception	RS 250 / 025 RS 250 / 050	RS 250 / 080 RS 250 / 100 RS 251 / 050	RS 251 / 080	RS 250 / 150 RS 251 / 100	RS 250 / 200
2	O-ring	1		0-014	0-018	0-036	0-044	0-046
		2	DN 50	0-014				
		2	before 1992			0-036		
4	O-ring	1		0-014	0-018	0-037	0-044	0-046
7	O-ring	1		0-007	0-009	0-009	0-009	0-009
8	O-ring	1		0-014	0-035	0-038	0-026	0-026
			RE 320	0-004				
9	O-ring	1		0-019	0-039	0-040	0-031	0-031
		4	RE 320	0-002				
			RE 390		0-002			
8	RE 485					0-003	0-003	
10	NBR-ring	2		N-001	N-002	N-002	N-002	N-002
			Valve 27.2		N-001			
		Valve 17.5	No NBR-ring					
11	O-ring	1		0-007	0-009	0-009	0-009	0-009
			Valve 27.2		0-007			
14	NBR-ring	2		N-001	N-003	N-003	N-003	N-003
17	O-ring	1		0-008				
20	O-ring	1		0-015	0-015	0-036	0-036	0-036
			Cast sealing cap	0-014	0-014	0-015	0-015	0-015
21	O-ring	1		0-012	0-012	0-016	0-016	0-016
24	O-ring	1		0-007	0-009	0-009	0-009	0-009
25	O-ring	1		0-001	0-001	0-001		
32	O-ring	1		0-007	0-007	0-007	0-009	0-009
35	O-ring	1		0-007	0-007	0-007	0-009	0-009
36	O-ring	1		0-013	0-013	0-013	0-014	0-014
O-ring set order number:				OS-001	OS-002	OS-003	OS-004	OS-005

Safety diaphragm

Item no.	Name	Quantity pcs.	RS 250 / 025 RS 250 / 050		RS 250 / 080; RS 250 / 100; RS 251 / 050 RS 251 / 080; RS 250 / 150; RS 251 / 100; RS 250 / 200			
			RE 205	RE 320	RE 205	RE 275	RE 385 / 390	RE 485
22	O-ring	1	O-029	O-033	O-029	O-041	O-042	O-043
23	Diaphragm	1	M-123	M-143	M-123	M-133	M-163	M-173
26	O-ring	1	O-013	O-013	O-013	O-013	O-013	O-013
Safety diaphragm set order number:			MS-123	MS-143	MS-123	MS-133	MS-163	MS-173

Example:

Name	Type	DN - nominal width	RE - Control device	D - nozzle (valve diameter)	SSV Control unit	Main-diaphragm	Option
Gas pressure regulator:	RS250	080	390*	27,5	MD-R	MB*	SM...

Spare parts according to tables in 9.3

Main diaphragm and O-ring: **MS-152**
 Intermediate diaphragm: **M-003**
 Valve plate: **VT-003**
 Valve plate SSV: **VT-202**
 Diaphragm SSV: **M-201**
 O-ring and sealing ring set: **OS-002**
 Safety diaphragm: **MS-163**

The allocation of individual parts is done according to the item no. in the tables in 9.3, conforming to the spare parts drawings in 9.1 and 9.2.

Note

When ordering, please state the serial number from the type plate.

Note

Example Composition of the factory number

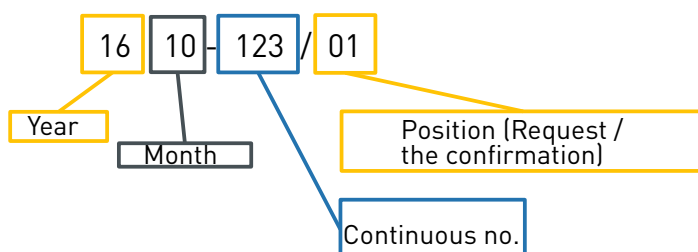

The replacement of parts must be performed only by trained and authorized persons.



NOTICE

*) When selecting the main diaphragm set for control device RE 385 / 390, a distinction has to be made between MB and GMB. The GMB diaphragm is standard equipment and is therefore not mentioned separately in the controller designation.

Declaration of Conformity

(Summary)

Manufacturer: Medenus Gas-Druckregeltechnik GmbH

Address: Saßmicker Hammer 40
D-57462 Olpe-Saßmicke

herewith declares that the products:

RS 250, RS 251 Gas pressure regulator with integrated
safety shut-off valve

have been subjected to an EC type examination and conform to
the basic requirements of the directives GAD 2009/142/EC
EC Gas Appliances Directive in the respective current version.

For devices that additionally carry the CE mark,
an EC-type-examination certificate has been issued according to:

2014/68/EU A III B EC Pressure Equipment Directive

Test report: CE-0085 / AZ 16/180/4301/210 (RS250/251)

The EC type-examination is based on the harmonised
European Standards and/or national standards:

DIN 334 (2009-07-01)

DIN 14382 (2009-07-01)

Marking (PIN) according to Gas Appliances Directive

CE-0085AQ0882 model RS 250

CE-0085AQ0883 model RS 251

Marking according to Pressure Equipment Directive



The quality assurance system (module D) is monitored
by the DVGW.

Olpe-Saßmicke,
2016-09-30

Martin Clemens
Managing Director

In the download area of our homepage, this document is available in different languages. You can use the following QR codes and links to go directly to this document in your language.



German:

[http://medenus.de/files/upload/
downloads/RS250/
BWA_RS250_251_de.pdf](http://medenus.de/files/upload/downloads/RS250/BWA_RS250_251_de.pdf)



English:

[http://medenus.de/files/upload/
downloads/RS250/
BWA_RS250_251_en.pdf](http://medenus.de/files/upload/downloads/RS250/BWA_RS250_251_en.pdf)



MEDENUS Gas-Druckregeltechnik GmbH

Fon +49 (0)2761 82788-0

Fax +49 (0)2761 82788-9

Saßmicker Hammer 40 / D-57462 Olpe

info@medenus.de

www.medenus.de

EN