

flowstar

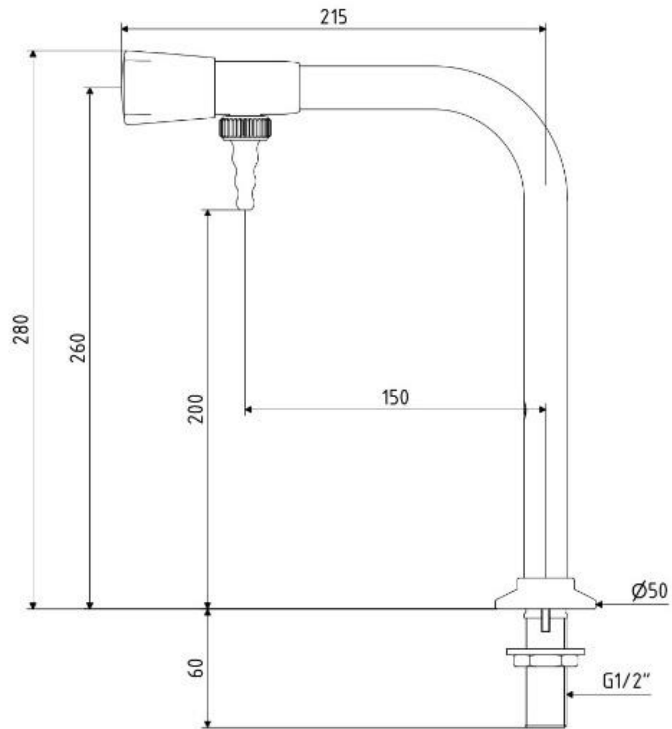

Description: Pillar tap with removable serrated nozzles.

Applications: Standard laboratory water tap for all applications where header tank supply is present (Full WRAS approval)

Options: Fixed or full-bore nozzles are available on request. Hot water.

Construction: All brass body, Rilsan plastic coated, white (RAL9016).

Chemical resistant plastic ABS handwheel, Identification coding to DIN13792

Connection and mounting: ½" BSP male flat ended shank x 60mm long with back nut.

Standard anti-rotation base with location pin. Two mounting holes 22mm and 5mm diameter required template enclosed.

Pressure and Flow: Maximum pressure 100PSI (Recommended 20PSI)

Flow Rate @ 20 psi = 12 Litre/min.

Spares: Hand wheel Assembly, Valve headwork

WRAS: Approved