

# **brownall**<sup>®</sup>

## **Guide to Air Elimination in Fluid Systems**

**Flowstar (UK) Limited**

**Tel: 01482 601030**

**Email: [sales@flowstar.co.uk](mailto:sales@flowstar.co.uk)**

*The removal of air is essential if water filled and other liquid carrying systems are to work efficiently. Trapped air can inhibit the filling of the system, the priming of pumps, reduce output and retard circulation. Air can also contribute to noise, cavitation and corrosion.*

### **Origins of Air In Systems**

#### **Residual Air:**

When a system is vented during filling, some air will remain trapped even after completion.

#### **Air penetrating the system:**

When the system temperature falls a reduction in pressure occurs, and as a result of the reduction of water volume, air can be sucked in through small leakage points. This situation would apply for example, when the expansion vessel is undersized.

#### **Dissolved Air:**

Water contains air in dissolved form and the air absorption capacity varies according to pressure and temperature.

#### **Gas generation:**

Gases develop due to electrical and bio-chemical reactions in heating systems.

### **Release Of Air from the System**

Manually operated vents of the air bottle type provide a temporary solution to the problem. However, it should be noted that these require frequent attention to cope with the air which Accumulates during the normal running period, therefore a vent giving a continuous and automatic process is generally preferred by the majority of engineers associated with system design.

### **Automatic Air Eliminators - Principal Of Operation**

The following basic principal of operation applies to the majority of types available in the market place today. Air collects at the high points of the system and enters the float chamber of the air eliminators thus reducing float buoyancy that allows air to escape through the seat orifice. As fluid replaces air, the float buoyancy is increased allowing the float assembly to rise and close the seat orifice.

### **The Importance Of A Clean System**

Dirt or other foreign matter can cause problems, reducing the efficiency of a system, particularly when applied to air elimination. It is therefore recommended that prior to the installation of automatic air eliminators the system is thoroughly flushed. In addition, a pipeline strainer should be installed immediately before the inlet to the AAE.

## **Selection Of The Most Suitable Automatic Air Eliminator**

With several types of air eliminator available, product evaluation relating to system requirements is essential. With this in mind, the following factors should be taken into consideration: -

**System Parameters:** - Select the correct type, ensuring that the pressure and temperature rating meet the requirement of the system.

**Materials of Construction:** - Quality of manufacture and materials used in construction are critical. Corrosion and clogging of valve mechanisms is a potential problem if incorrect materials are used.

**Reliability:** - An automatic valve, usually operating in an inaccessible roof space or system header, must be capable of long term trouble free operation.

With proven reliability extending over many years the Brownall range of Automatic Air Eliminators meets the above criteria and is number one choice with professional building services consulting engineers and specifying authorities.

### **Brownall AAE Technical Specification**

Type A - With integral filter

Type B - With integral filter and lock shield isolator valve

Type C - With integral filter, lock shield isolator valve and outlet check valve

Type D - With side inlet and integral filter

Connections: Screwed ½" BSP female inlet 3/8" BSP Male outlet

Pressure Rating: Up to 10 Bar

Temperature Rating: Up to 93°C (200°F)

Recommended Minimum Working Pressure: 0.15bar (5ft effective head)

#### **Materials of construction**

Valve Body: Gunmetal BS EN 1982: 1999 CC 491K (formerly BS1400 LG2)

Valve stem: Stainless Steel 316S16

Valve: PTFE glass filled

Float: Stainless Steel 316S16

Weight: 1.3Kg

### **Typical Questions for Selection of Air Eliminator**

Q. What is the pressure rating of the system?

Rec. Please refer to performance rating table (page 5) for most suitable A/E.

Q. What is the temperature rating of the system?

Rec. Please refer to performance rating table (page 5) for most suitable A/E.

Q. Is the valve required to be isolated from the system?

Rec. If no, select type A. If yes, select type B.

Q. Is the system prone to vacuum (air being drawn back in)?

Rec. Select type C (with outlet check valve).

Q. Does the system set-up require a horizontal inlet?

Rec. Select type D (with horizontal inlet).

**N.B.** All HPHW Air Eliminators have flanged connections (table to be specified) for higher-pressure applications.

## **Installation and Mounting**

The unit should be fitted at any high points in the heating system where air may collect. The valve is suitable for pressures up to 10 bar (145 lbf/in<sup>2</sup>) maximum and temperatures up to 93°C (200°F). The ball check valve version (Type C) should be specified if it is necessary to prevent air being drawn into the system.

### **Installation**

The unit should be mounted with the axis vertical (see diagram overleaf). It is recommended that the vent pipe work is connected to the outlet in order to discharge air and any seepage of fluid to a suitable safe point. The pipe work layout should allow for any maintenance that may be required. A drain plug is fitted at the base of the float chamber to assist draining. To ensure minimum maintenance it is recommended that a strainer is fitted before the inlet of the AAE. This is especially useful if access to the valve is difficult.

### **Maintenance**

If an isolator has been fitted, or if the air eliminator has its own isolator (i.e. types B & C), the valve should be shut. The drain plug at the base of the valve chamber may be removed to drain the body and for access to the valve spindle. It is then easy to rectify seepage problems due to foreign matter lodging on the valve seat. The valve spindle can be raised and then rotated using a small screwdriver on order to clear the seating of debris. Undue pressure should not be applied.

If the leakage persists, the valve may be dismantled without removal from the inlet pipe work. A suitable vessel should be available to collect any water spillage. During the operation any discharge pipe work fitted should be disconnected and held away from the valve. The six 10mm A/F screws should be removed and the cover carefully raised vertically to avoid bending the float spindle. The valve seating should be checked for cleanliness. The float should be checked for damage or water ingress and the spindle checked for straightness. If the spindle or PTFE needle require changing it is recommended that the float assembly is replaced as a matched unit and is available as a service kit.

The mesh filter (where fitted) should be checked for debris and damage. The filter can be removed by using a screwdriver to prise off the retaining circlip and lifting off the body spigot. Replace the cleaned filter by centralising it over the body spigot and refitting the retaining circlip. **It is vital that the circlip is refitted.** The valve chamber and the gasket face should be cleaned before re-assembly. Using a new gasket fit the float assembly and cover carefully to avoid damage to the PTFE needle. The fixing screws should be refitted and tightened evenly to avoid distortion of the flange. Check the free action of the needle spindle through the drain hole and the drain plug should then be replaced, ensuring that the fibre sealing washer is in place. The isolator may then be opened to check that no leakage is present at the outlet or flange face. The discharge pipe work should then be reconnected.

### **Brownall Automatic Air Eliminator Selection Chart**

Air flow rates:

<b>Pressure (Bar)</b>	<b>Types A, B, C Flow Rate (L/min)</b>	<b>Type D Flow Rate (L/min)</b>
0.5	47	22
1.0	65	29
1.5	75	33
2.0	83	35
2.5	89	38
3.0	94	39
3.5	97	41
4.0	101	42
4.5	103	43
5.0	107	45

Performance ratings:

<b>AAE Type</b>	<b>Temperature Ratings</b>	<b>Pressure Ratings</b>
A	93°C (200°F)	Max 10 Bar (150 psi) Min 0.12 Bar (2.25 psi) (5ft Effective Head)
B		
C		
D		
MPHW	149°C (300°F)	Max 7 Bar (100 psi)
HPHW / F	182° (360°F)	Max 10.5 Bar (155 psi)
HPHW / H	204°C (400°F)	Max 17 Bar (250 psi)

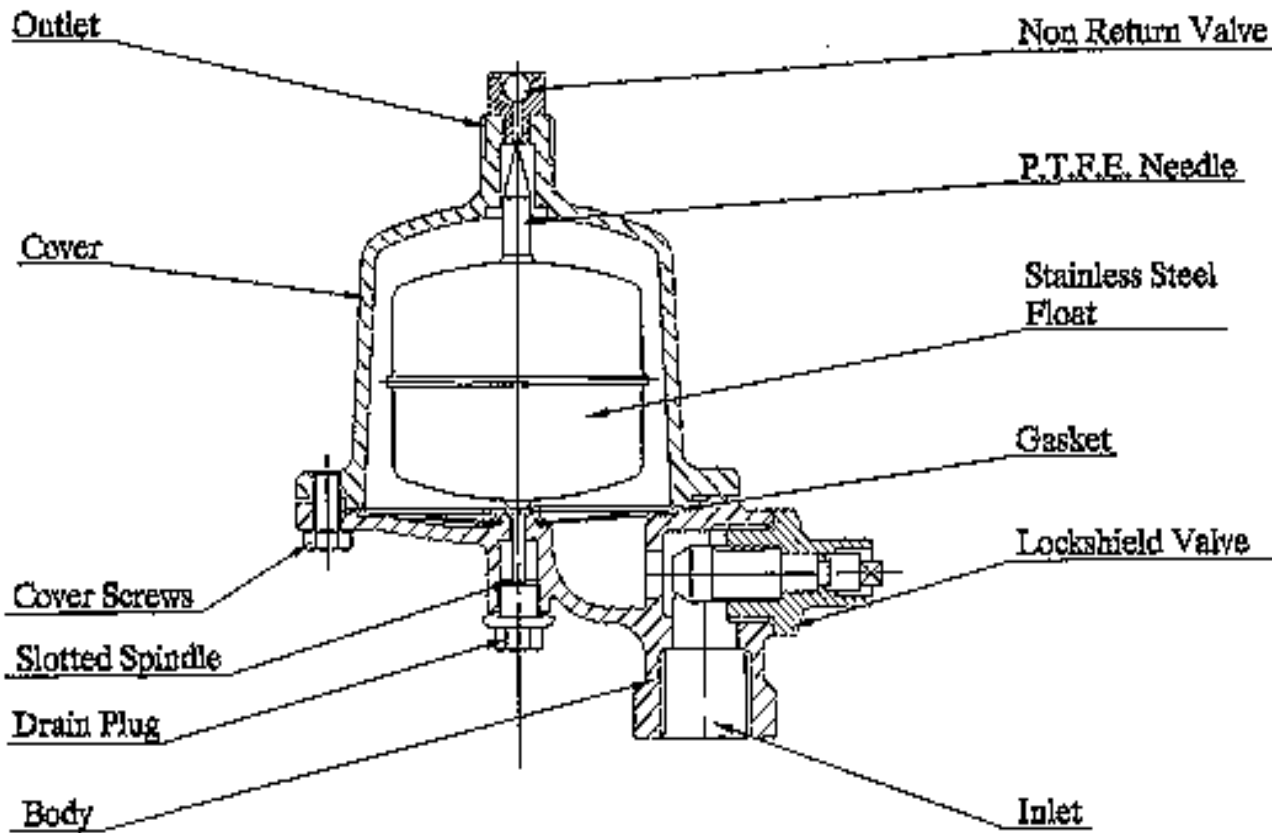

Assembly Drawing of  
Type C Air Eliminator

### **Distributors**

Flowstar  
Units 1 & 2 Gillett Sreet  
Hull  
HU3 4JA

Telephone: 01482 601030

Email: [sales@flowstar.co.uk](mailto:sales@flowstar.co.uk)