



AUTOMATIC AIR ELIMINATOR

TYPE A

TYPE B (with integral lock shield isolator)

TYPE C (with integral lock shield isolator and outlet check valve)

TYPE D (with side inlet)

MOUNTING

The unit should be fitted at any points in the heating system where air may collect. The valve is suitable for pressure up to 10 bar (145 lbf/sq in) maximum and temperatures up to 93°C. The ball check valve version should be specified if it is necessary to prevent air being drawn into the system.

CONNECTIONS

Initial screwed 1/2" BSP Female Outlet screwed 3/8" BSP Male.

INSTALLATION

The unit should be mounted with the axis vertical (see diagram).

It is necessary that vent pipework is connected to the outlet in order to discharge air and any seepage to a suitable safe point.

The pipework layout should allow for any maintenance that may be required. A drain plug is fitted at the base of the final chamber to assist draining.

In order to ensure minimum maintenance it is recommended that the strainer is fitted to the inlet of the automatic air eliminator. This is especially useful if access to the valve is difficult.

MAINTENANCE

If an isolator has been fitted or if the air eliminator has its own isolator valve, this valve should be shut. The drain plug at the base of the valve chamber may be removed for access to the valve spindle. It is then easy to rectify seepage problems due to foreign matter lodging on the valve seal. The valve spindle can be raised and then rotated using a small screwdriver in order to clear the seating of debris.

If the leakage problem persists then the valve may be dismantled and the interior checked. A suitable vessel should be at hand to collect any water spillage.

During this operation any discharge pipework should be disconnected and held away from the valve. The six 10mm A/F screws should be removed and the cover should be carefully raised to avoid bending the float spindle. The valve seating should be checked for cleanliness. The float may be checked for damage or water ingress and the spindle checked for straightness. If the seating, float, spindle or needle requires changing then it is recommended that the float assembly and seat are replaced as a matched pair as supplied with the service kit.

The valve chamber and the gasket face should be cleaned before reassembly. After fitting the cover and float, the fixing screws should be fitted and tightened evenly to avoid distorting the flange. The drain cock should be replaced, if removed, using sealant. The isolator may then be opened to check that no leakage is present at the outlet. The discharge pipework should then be reconnected.

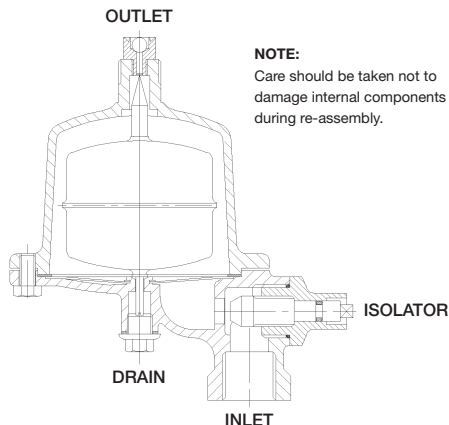

brownall™

DELTA ROAD,
ST HELENS, WA9 2ED
TELEPHONE: +44 (0)1744 458 615

FAX: +44 (0)1744 453 675
EMAIL: brownallsales@cranebsu.com
www.brownall.com

Every effort has been made to ensure that the information contained in this publication is accurate at the time of publishing. Crane Ltd assumes no responsibility or liability for typographical errors or omissions or for any misinterpretation of the information within the publication and reserves the right to change without notice.

B.AUTO.ELIM.A5.0610
IOM.0119 REV.2

CRANE BUILDING SERVICES & UTILITIES

www.cranebsu.com