

Tavola riassuntiva delle principali caratteristiche costruttive e di funzionamento Main fabrication and operating characteristics table

Mod.	Tipo di cappello	Certificati	Connessioni
131	mezzo boccaglio	Cappello chiuso	Connessioni flangiate EN e ANSI (per esecuzioni diverse, fare riferimento all'Ufficio Tecnico)
131b	boccaglio pieno	(molla coperta)	
132	mezzo boccaglio	Cappello aperto	diverse, fare riferimento all'Ufficio Tecnico)
132b	boccaglio pieno	(molla scoperta)	

Type	Bonnet type	Certifications	Connections
131	semi nozzle	Closed	Flanged connections EN and ANSI (for different executions please refer to Technical Dept.)
131b	full nozzle	(covered spring)	
132	semi nozzle	Open	Flanged connections EN and ANSI (for different executions please refer to Technical Dept.)
132b	full nozzle	(uncovered spring)	

Principali caratteristiche di funzionamento

Applicazioni	Aeriformi - liquidi
Intervallo pressioni di taratura p	da 0.20 a 40 barg

Materiali di costruzione di corpo e cappello	Interv. temp. di esercizio*
Corpo e cappello in ghisa	da -10 a +300°C
Corpo in acciaio al carbonio e capp. aperto in ghisa	da -10 a +400°C
Corpo in acciaio al carbonio e cappello chiuso in ghisa	da -10 a +350°C
Corpo e cappello in acciaio al carbonio	da -20 a +425°C
Corpo e cappello in acciaio inossidabile	da -196 a +537°C

* Per temperature e pressioni diverse da quelle riportate nella presente tabella, fare riferimento all'Ufficio Tecnico.

Main operating characteristics

Applications	Gaseous - liquid
Set pressure p range:	from 0.20 to 40 barg

Body and bonnet construction material	Temperature Range*
Cast iron body and bonnet	from -10 to +300°C
Carbon steel body and cast iron open bonnet	from -10 to +400°C
Carbon steel body and cast iron closed bonnet	from -10 to +350°C
Carbon steel body and bonnet	from -20 to +425°C
Stainless steel body bonnet	from -196 to +537°C

* For temperature and pressure different than those in this table, ask to Technical Department.

Coefficienti di efflusso	Aeriformi	Liquidi
Kd (certificato)	0.41	0.35
Kdr (Kd • 0.9) (ridotto)	0.37	0.32

	Aeriformi - liquidi
Sovrapressione	+10% di p se p ≥ 1 bar +0.1 bar se p < 1 bar
Scarto di chiusura	-10% di p se p ≥ 1 bar -0.1 bar se p < 1 bar

Massima contropressione ammessa generata ed imposta***

Valvola senza soffiutto di bilanciamento	4% della press. di taratura (aeriformi) 5% della press di taratura (liquidi)
Valvola con soffiutto di bilanciamento	20% della press di taratura (aeriformi e liquidi)

***Per l'impiego con contropressione imposta e per contropressioni superiori ai valori indicati, fare riferimento all'Ufficio Tecnico.

Coefficient of discharge	Gaseous	Liquid
Kd (certified)	0.41	0.35
Kdr (Kd • 0.9) (derated)	0.37	0.32

	Gaseous- liquid
Overpressure	+10% of p if p ≥ 1 bar +0.1 bar if p < 1 bar
Blow down	-10% of p if p ≥ 1 bar -0.1 bar if p < 1 bar

Maximum allowable built up and superimposed back pressure pb***

Safety valves without balancing bellow	4% of set pressure (gas and vapour) 5% of set pressure (liquid)
Safety valves with balancing bellow	20% of set pressure (gas, vapour and liquid)

*** In case of superimposed backpressure, please refer to Technical Department.

Classificazione corpi

Materiale	Entrata	Uscita
Corpo Ghisa	EN PN 16	EN PN 16
	ASME CL 150 (125)	ASME CL 150 (125)
Acciaio	da EN PN 16	da EN PN 16
	a EN PN 40	a EN PN 40
	ASME CL 150	ASME CL 150

LEGENDA: p= pressione di taratura (barg); pb= contropressione (barg).

Note

Valvole di sfioro
Le valvole della serie 130 sono disponibili anche nella versione valvole di sfioro. Le Valvole di sfioro, identificate dalla lettera R posta accanto al numero identificante il modello, si caratterizzano come accessori (dispositivi) a pressione aventi funzione di servizio. I materiali di costruzione, le dimensioni ed i limiti di utilizzo secondo il rapporto pressione/temperatura delle valvole di sfioro, sono gli stessi validi per le valvole di sicurezza della Serie 130.

Alcuni dati riportati nella presente pagina possono variare su specifica richiesta, previa analisi e approvazione delle funzioni competenti di Besa S.p.A.

Body Ratings

Body material	PN valves Inlet	Outlet
Cast iron	EN PN 16	EN PN 16
	ASME CL 150 (125)	ASME CL 150 (125)
Steel	from EN PN 16	from EN PN 16
	to EN PN 40	to EN PN 40
	ASME CL 150	ASME CL 150

LEGENDA: p=set pressure (barg) pb= backpressure (barg)

Note

Relief Valves:
130 Series Safety valves are also available as Relief valves. Relief valves, identified by the letter R after the type number, are devices with an operational function, having pressure-bearing housings. Materials, dimensions and application limits depending on Pressure/Temperature ratio for Relief Valves are the same of Safety Valves 130 Series.

Some information given on these pages can be changed upon specific requests, after BESA qualified office approval.

Valvole di sicurezza Modello 131-132

Safety Valves Type 131-132

Legenda materiali std.

Descrizione	131-G / 132-G	131-C / 132-C	131-I
1 Corpo Valvola	Ghisa G250	Acciaio al Carbonio ASTM A216 WCB - EN 1.0619	Acciaio inossidabile ASTM A351 CF8M - EN 1.4408
2 Sede	Acciaio inossidabile ASTM 316 - EN 1.4401	Acciaio inossidabile ASTM 316 - EN 1.4401	Acciaio inossidabile ASTM 316 - EN 1.4401
3 Otturatore	Acciaio inossidabile ASTM 420 - EN 1.4028	Acciaio inossidabile ASTM 420 - EN 1.4028	Acciaio inossidabile ASTM 316 - EN 1.4401
4 Sfera	Acciaio inossidabile ASTM 420 - EN 1.4028	Acciaio inossidabile ASTM 420 - EN 1.4028	Acciaio inossidabile ASTM 316 - EN 1.4401
5 Piattello Guida	Ghisa GS450/10 con bussola ASTM 430F Tenifer	Ghisa GS450/10 con bussola ASTM 430F Tenifer o acciaio inossidabile ASTM 316 - EN 1.4401	Acciaio inossidabile ASTM 316 - EN 1.4401
6 Ralla Molla	Acciaio AVP	Acciaio AVP	Acciaio inossidabile ASTM 316 - EN 1.4401
7 Asta	Acciaio inossidabile ASTM 430F - EN 1.4104	Acciaio inossidabile ASTM 430F - EN 1.4104	Acciaio inossidabile ASTM 316 - EN 1.4401
8 Molla	Acciaio al carbonio Acciaio legato	Acciaio al carbonio Acciaio legato	Acciaio inossidabile ASTM 316 S42
9 Vite di regolazione	Ottone OT58/ Acciaio AVP	Ottone OT58/ Acciaio AVP	Acciaio inossidabile ASTM 316 - EN 1.4401 con bussola in Ptfte
10 Cappello	Ghisa GS450/10	Ghisa GS450/10 o Acciaio al Carbonio ASTM A216 WCB - EN 1.0619	Acciaio inossidabile ASTM A351 CF8M - EN 1.4408
11 Cappuccio H4 a tenuta con leva	Ghisa GS450/10	Ghisa GS450/10	Acciaio inossidabile ASTM A351 CF8M - EN 1.4408

Dimensioni scartamenti (mm)

DN E	131-G / 132-G		131-C / 132-C / 131-I		H
	FLANGE EN PN16/PN16 PN25/PN25	FLANGE ANSI/ASME CL150/CL150	FLANGE EN PN16/PN16 PN25/PN25 PN40/PN40	FLANGE ANSI/ASME CL150/CL150	
15	90	85.1	90	85.1	223
20 x 20	95	89.7	95	89.7	223
20 x 25	100	96.3	100	96.3	223
25	100	96.3	100	96.3	223
32	105	102.9	105	102.9	223
40	115	114.5	115	114.5	223
50	127	126	125	124	273
65	145	147.2	145	145.2	330
80	157	158.8	155	154.8	375
100	179	178.8	175	174.8	435
125	204	201.8	200	197.8	545
150	229	228.4	225	222.4	645

dimensioni indicative, da confermare in caso di ordine

Tipi di cappuccio

Cappuccio a tenuta tipo H4 con leva di sollevamento dell'otturatore

Cappuccio aperto tipo H3 con leva di sollevamento dell'otturatore

Cappuccio a tenuta tipo H2

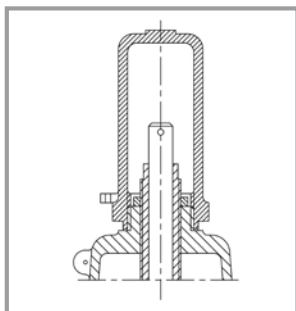
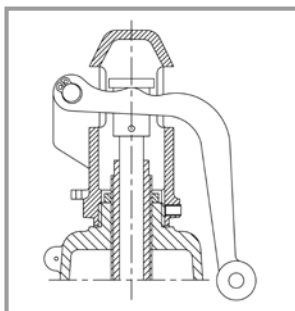
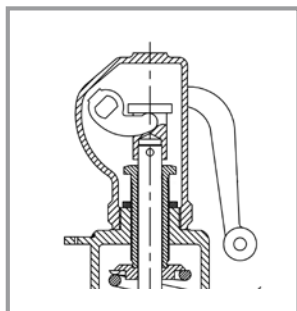

Note

A richiesta e con l'approvazione dell'Ufficio Tecnico, la costruzione delle valvole può essere eseguita utilizzando componenti di materiale diverso da quello indicato nella tabella soprastante.

Dimensioni caratterizzanti le prestazioni fluidodinamiche

DN E Entrata	do diametro geometrico di efflusso orifizio	Area geometrica di efflusso cm ²	DN U Uscita	Alzata otturatore mm	Max pressione di taratura corpo valvola	
					Ghisa barg	Acciaio
15-1/2"	12.5	1.23	15-1/2"	2.3	16	40
20-3/4"	18	2.54	20-3/4"	4.4	16	40
20-3/4"	18	2.54	25-1"	3.1	16	40
25-1"	18	2.54	25-1"	3.1	16	40
32-1"1/4	18	2.54	32-1"1/4	2.0	16	40
40-1"1/2	23	4.15	40-1"1/2	2.5	16	40
50-2"	29	6.61	50-2"	3.2	16	40
65-2"1/2	37	10.75	65-2"1/2	4.0	16	37
80-3"	46	16.62	80-3"	5.1	16	35
100-4"	60	28.27	100-4"	7.1	16	30
125-5"	74	43.00	125-5"	8.5	16	25
150-6"	92	66.48	150-6"	11.4	16	16

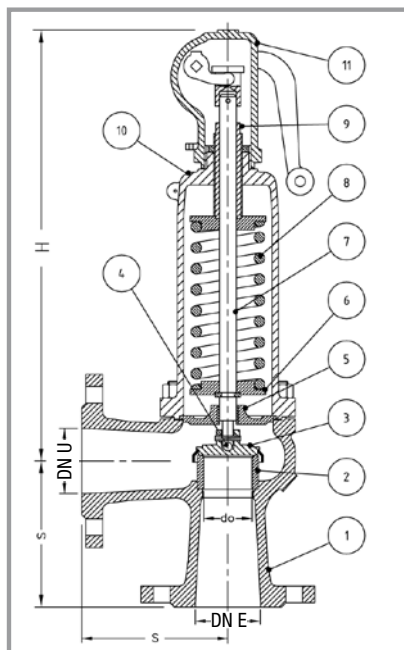

Valvole di sicurezza Modello 131-132

Safety Valves Type 131-132

Std. material legenda

Description	131-G / 132-G Valve with cast iron body	131-C / 132-C Valve with carbon steel body	131-I Valve with stainless steel body
1 Valve body	Cast iron G250	Carbon steel ASTM A216 WCB - EN 1.0619	Stainless steel ASTM A351 CF8M - EN 1.4408
2 Seat	Stainless steel ASTM 316 - EN 1.4401	Stainless steel ASTM 316 - EN 1.4401	Stainless steel ASTM 316 - EN 1.4401
3 Disc	Stainless steel ASTM 420 - EN 1.4028	Stainless steel ASTM 420 - EN 1.4028	Stainless steel ASTM 316 - EN 1.4401
4 Ball	Stainless steel ASTM 420 - EN 1.4028	Stainless steel ASTM 420 - EN 1.4028	Stainless steel ASTM 316 - EN 1.4401
5 Complete Guide	Cast iron GS450/10 with bush ASTM 430F Tenifer	Cast iron GS450/10 with bush ASTM 430F Tenifer or stainless steel ASTM 316 - EN 1.4401	Stainless steel ASTM 316 - EN 1.4401
6 Spring plate	AVP steel	AVP steel	Stainless steel ASTM 316 - EN 1.4401
7 Spindle	Stainless steel ASTM 430F - EN 1.4104	Stainless steel ASTM 430F - EN 1.4104	Stainless steel ASTM 316 - EN 1.4401
8 Spring	Carbon steel Alloy steel	Carbon steel Alloy steel	Stainless steel ASTM 316 S42
9 Pressure adjusting screw	Brass OT58/AVP steel	Brass OT58/AVP steel	Stainless steel ASTM 316 - EN 1.4401 with bush in Ptfte
10 Bonnet	Cast iron GS450/10	Cast iron GS450/10 or Carbon steel ASTM A216 WCB - EN 1.0619	Stainless steel ASTM A351 CF8M - EN 1.4408
11 Tight cap H4 with lifting lever	Cast iron GS450/10	Cast iron GS450/10	Stainless steel ASTM A351 CF8M - EN 1.4408

Dimensions defining valve performances

DN I Inlet	Actual orifice diameter	Actual discharge area	DN O Outlet	Disc lift	Max set pressure valve body	Cast iron barg	Cast Steel
	mm	cm ²		mm.			
15-1/2"	12.5	1.23	15-1/2"	2.3		16	40
20-3/4"	18	2.54	20-3/4"	4.4		16	40
20-3/4"	18	2.54	25-1"	3.1		16	40
25-1"	18	2.54	25-1"	3.1		16	40
32-1 1/4"	18	2.54	32-1 1/4"	2.0		16	40
40-1 1/2"	23	4.15	40-1 1/2"	2.5		16	40
50-2"	29	6.61	50-2"	3.2		16	40
65-2 1/2"	37	10.75	65-2 1/2"	4.0		16	37
80-3"	46	16.62	80-3"	5.1		16	35
100-4"	60	28.27	100-4"	7.1		16	30
125-5"	74	43.00	125-5"	8.5		16	25
150-6"	92	66.48	150-6"	11.4		16	16

Center to face dimensions (mm)

DN I	131-G / 132-G		131-C / 132-C / 131-I		H
	EN FLANGE PN16/PN16 PN25/PN25	ANSI/ASME FLANGE CL150/CL150	EN FLANGE PN16/PN16 PN25/PN25 PN40/PN40	ANSI/ASME FLANGE CL150/CL150	
15	90	85.1	90	85.1	223
20 x 20	95	89.7	95	89.7	223
20 x 25	100	96.3	100	96.3	223
25	100	96.3	100	96.3	223
32	105	102.9	105	102.9	223
40	115	114.5	115	114.5	223
50	127	126	125	124	273
65	145	147.2	145	145.2	330
80	157	158.8	155	154.8	375
100	179	178.8	175	174.8	435
125	204	201.8	200	197.8	545
150	229	228.4	225	222.4	645

approximate dimensions to be confirmed at order

Caps

Tight Cap H4 with lifting lever

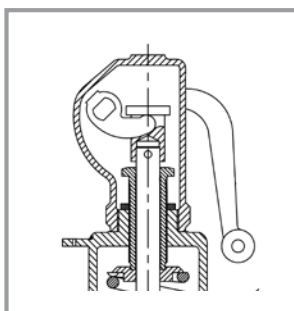

Open Cap H3 with disc lifting lever

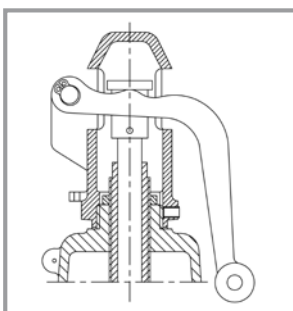

Tight Cap H2

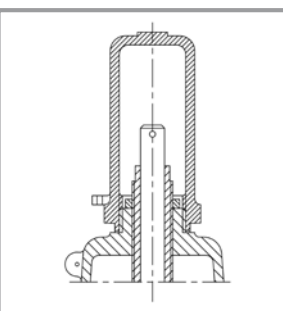

Note

Valves can be manufactured with materials different than those in this table upon request and after Besa Technical Dept. approval.

Valvole di sicurezza Modello 131b-132b
Safety Valves Type 131b-132b

Legenda materiali std.

Descrizione	131b-C / 132b-C	131b-I
	Valvola con corpo in acciaio al carbonio	Valvola con corpo in acciaio inossidabile
1 Corpo Valvola	Acciaio al carbonio ASTM A216 WCB - EN 1.0619	Acciaio inossidabile ASTM A351 CF8M - EN 1.4408
2 Boccaglio	Acciaio inossidabile ASTM 316 - EN 1.4401	Acciaio inossidabile ASTM 316 - EN 1.4401
3 Otturatore	Acciaio inossidabile ASTM 420 - EN 1.4028	Acciaio inossidabile ASTM 316 - EN 1.4401
4 Sfera	Acciaio inossidabile ASTM 420 - EN 1.4028	Acciaio inossidabile ASTM 316 - EN 1.4401
5 Piattello Guida	Ghisa GS450/10 con bussola in ASTM 430F Tenifer o acciaio inossidabile ASTM 316 - EN 1.4401	Acciaio inossidabile ASTM 316 - EN 1.4401
6 Ralla Molla	Ferro AVP	Acciaio inossidabile ASTM 316 - EN 1.4401
7 Asta	Acciaio inossidabile ASTM 430F - EN 1.4104	Acciaio inossidabile ASTM 316 - EN 1.4401
8 Molla	Acciaio al carbonio Acciaio legato	Acciaio inossidabile ASTM 316 S42 - EN 1.4401
9 Vite di regolazione	Ottone OT58/ Acciaio AVP	Acciaio inossidabile ASTM 316 - EN 1.4401 con bussola in Ptfe
10 Cappello	Ghisa GS450/10 o acciaio al carbonio ASTM A216 WCB - EN 1.0619	Acciaio inossidabile ASTM A351 CF8M - EN 1.4408
11 Cappuccio H4 a tenuta con leva	Ghisa GS450/10	Acciaio inossidabile ASTM A351 CF8M - EN 1.4408

Dimensioni caratterizzanti le prestazioni fluidodinamiche

DN E Entrata	do diametro geometrico orifizio mm	Area geometrica di efflusso cm ²	DN U Uscita	Alzata otturatore mm	Max pressione di taratura barg
15-1/2"	12.5	1.23	15-1/2"	2.3	40
20-3/4"	18	2.54	20-3/4"	4.4	40
20-3/4"	18	2.54	25-1"	3.1	40
25-1"	18	2.54	25-1"	3.1	40
32-1"1/4	18	2.54	32-1"1/4	2.0	40
40-1"1/2	23	4.15	40-1"1/2	2.5	40
50-2"	29	6.61	50-2"	3.2	40
65-2"1/2	37	10.75	65-2"1/2	4.0	37
80-3"	46	16.62	80-3"	5.1	35
100-4"	60	28.27	100-4"	7.1	30
125-5"	74	43.00	125-5"	8.5	25
150-6"	92	66.48	150-6"	11.4	16

Dimensioni scartamenti (mm)

131b-C / 132b-C / 131b-I	131-C / 132-C / 131-I
FLANGE EN	FLANGE
PN16/PN16	ANSI/ASME
PN25/PN25	CL 150/CL 150
PN40/PN40	

DN E	S	S	H
15	90	85,1	223
20 x 20	95	89,7	223
20 x 25	100	96,3	223
25	100	96,3	223
32	105	102,9	223
40	115	114,5	273
50	125	124	273
65	145	145,2	330
80	155	154,8	375
100	175	174,8	435
125	200	197,8	545
150	225	222,4	645

dimensioni indicative, da confermare in caso di ordine

Tipi di cappuccio

Cappuccio a tenuta tipo H4
con leva di sollevamento dell'otturatore

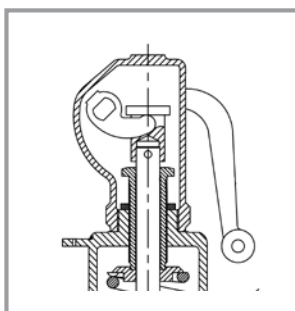

Cappuccio aperto tipo H3 con leva
di sollevamento dell'otturatore

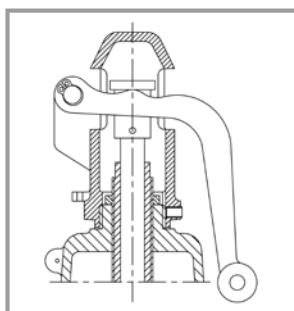

Cappuccio a tenuta tipo H2

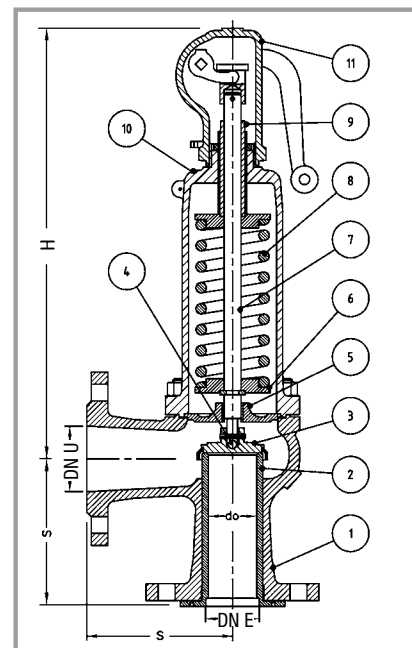
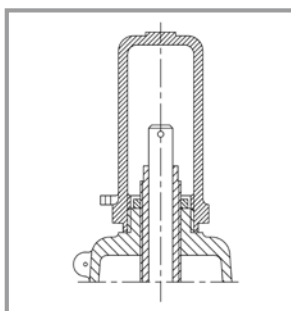

Note

A richiesta e con l'approvazione dell'Ufficio Tecnico, la costruzione delle valvole può essere eseguita utilizzando componenti di materiale diverso da quello indicato nella tabella soprastante.

Valvole di sicurezza Modello 131b-132b

Safety Valves Type 131b-132b

Std. material legenda

Description	131b-C / 132b-C Valve with carbon steel body	131b-I Valve with stainless steel body
1 Valve body	Carbon steel ASTM A216 WCB - EN 1.0619	Stainless steel ASTMA351 CF8M - EN 1.4408
2 Nozzle	Stainless steel ASTM 316 - EN 1.4401	Stainless steel ASTM 316 - EN 1.4401
3 Disc	Stainless steel ASTM 420 - EN 1.4028	Stainless steel ASTM 316 - EN 1.4401
4 Ball	Stainless steel ASTM 420 - EN 1.4028	Stainless steel ASTM 316 - EN 1.4401
5 Complete Guide	Cast iron GS450/10 with bush ASTM 430F Tenifer	Stainless steel ASTM 316 - EN 1.4401
6 Spring plate	AVP steel	Stainless steel ASTM 316 - EN 1.4401
7 Spindle	Stainless steel ASTM 430F - EN 1.4104	Stainless steel ASTM 316 - EN 1.4401
8 Spring	Carbon steel Alloy steel	Stainless steel ASTM 316 S42
9 Pressure adjusting screw	Brass OT58/AVP steel	Stainless steel ASTM 316 - EN 1.4401 with bush in Ptfte
10 Bonnet	Cast iron GS450/10 or Carbon steel ASTM A216 WCB - EN 1.0619	Stainless steel ASTMA351 CF8M - EN 1.4408
11 Tight cap H4 with lifting lever	Cast iron GS450/10	Stainless steel ASTMA351 CF8M - EN 1.4408

Dimensions defining valve performances

DN I Inlet	Actual orifice diameter mm	Actual discharge area cm ²	DN O Outlet	Disc lift mm.	Max set pressure barg
15-1/2"	12.5	1.23	15-1/2"	2.3	40
20-3/4"	18	2.54	20-3/4"	4.4	40
20-3/4"	18	2.54	25-1"	3.1	40
25-1"	18	2.54	25-1"	3.1	40
32-1"1/4	18	2.54	32-1"1/4	2.0	40
40-1"1/2	23	4.15	40-1"1/2	2.5	40
50-2"	29	6.61	50-2"	3.2	40
65-2"1/2	37	10.75	65-2"1/2	4.0	37
80-3"	46	16.62	80-3"	5.1	35
100-4"	60	28.27	100-4"	7.1	30
125-5"	74	43.00	125-5"	8.5	25
150-6"	92	66.48	150-6"	11.4	16

Center to face dimensions (mm)

131b-C / 132b-C / 131b-I EN FLANGE PN16/PN16 PN25/PN25 PN40/PN40	131-C / 132-C / 131-I ANSI/ASME FLANGE CL 150/CL 150
--	---

DN I	S	S	H
15	90	85,1	223
20 x 20	95	89,7	223
20 x 25	100	96,3	223
25	100	96,3	223
32	105	102,9	223
40	115	114,5	273
50	125	124	273
65	145	145,2	330
80	155	154,8	375
100	175	174,8	435
125	200	197,8	545
150	225	222,4	645

approximate dimensions to be confirmed at order

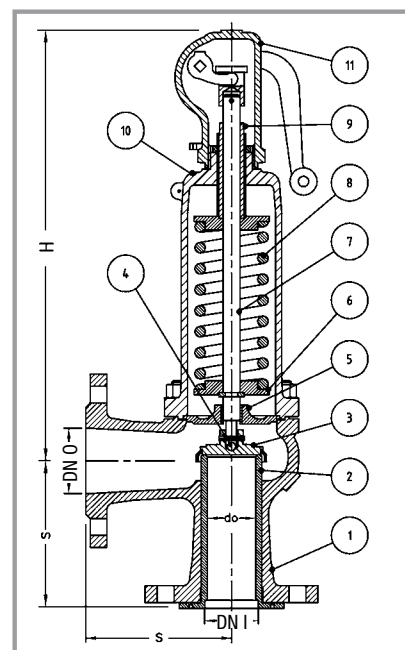

Caps

Tight Cap H4 with lifting lever

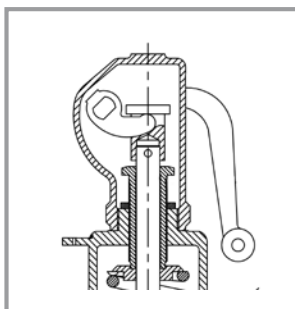

Open Cap H3 with disc lifting lever

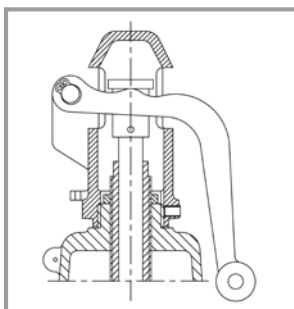

Tight Cap H2

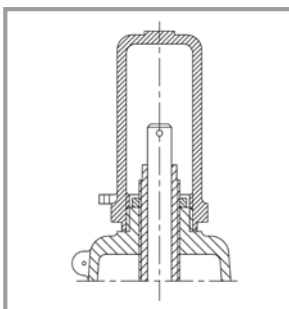

Note

Valves can be manufactured with materials different than those in this table upon request and after Besa Technical Dept. approval.

Tabella delle Portate / Flow rate table

Pressione di taratura P / Set pressure P	DN 15 - do 12.5				DN 20 - do 18			DN 25 - do 18			DN 32 - do 18			DN 40 - do 23			DN 50 - do 29			
	acqua (L) / water	aria (G) / air	vapore d'acqua sat. / sat. steam		acqua (L) / water	aria (G) / air	vapore d'acqua sat. / sat. steam	acqua (L) / water	aria (G) / air	vapore d'acqua sat. / sat. steam	acqua (L) / water	aria (G) / air	vapore d'acqua sat. / sat. steam	acqua (L) / water	aria (G) / air	vapore d'acqua sat. / sat. steam	acqua (L) / water	aria (G) / air	vapore d'acqua sat. / sat. steam	
	a 25°C	a 25°C			a 25°C	a 25°C		a 25°C	a 25°C		a 25°C	a 25°C		a 25°C	a 25°C		a 25°C	a 25°C		
bar	kg/h	kg/h	kg/h	kg/h	kg/h	kg/h	kg/h	kg/h	kg/h	kg/h	kg/h	kg/h	kg/h	kg/h	kg/h	kg/h	kg/h	kg/h	kg/h	kg/h
0,25	1.171	40	26	2.434	87	53	2.434	87	53	2.434	87	53	3.994	136	87	6.350	216	145		
0,5	1.536	53	33	3.203	116	70	3.203	116	70	3.203	116	70	5.230	182	114	8.315	289	190		
0,75	1.830	65	41	3.813	142	85	3.813	142	85	3.813	142	85	6.226	221	139	9.898	352	235		
1	2.084	76	48	4.338	158	101	4.338	158	101	4.338	158	101	7.083	258	165	11.260	411	263		
1,5	2.562	99	62	5.313	205	129	5.313	205	129	5.313	205	129	8.675	335	211	13.792	533	336		
2	2.958	119	75	6.135	248	156	6.135	248	156	6.135	248	156	10.017	405	256	15.926	644	407		
2,5	3.308	144	90	6.860	298	188	6.860	298	188	6.860	298	188	11.200	488	306	17.806	775	488		
3	3.624	165	103	7.514	342	215	7.514	342	215	7.514	342	215	12.269	559	351	19.506	889	558		
4	4.184	207	129	8.677	430	268	8.677	430	268	8.677	430	268	14.167	702	438	22.524	1.117	697		
5	4.678	249	155	9.701	518	321	9.701	518	321	9.701	518	321	15.840	846	525	25.182	1.345	835		
6	5.125	292	180	10.627	606	374	10.627	606	374	10.627	606	374	17.352	989	611	27.586	1.573	972		
7	5.536	334	206	11.479	694	427	11.479	694	427	11.479	694	427	18.742	1.133	698	29.797	1.802	1.109		
8	5.918	377	231	12.272	782	480	12.272	782	480	12.272	782	480	20.037	1.277	784	31.854	2.030	1.246		
9	6.277	419	256	13.016	870	532	13.016	870	532	13.016	870	532	21.252	1.421	869	33.787	2.259	1.383		
10	6.616	462	282	13.720	959	585	13.720	959	585	13.720	959	585	22.402	1.565	955	35.615	2.489	1.519		
12	7.248	547	332	15.030	1.136	689	15.030	1.136	689	15.030	1.136	689	24.540	1.854	1.125	39.015	2.949	1.789		
14	7.829	633	382	16.235	1.313	793	16.235	1.313	793	16.235	1.313	793	26.507	2.144	1.296	42.141	3.409	2.060		
16	8.370	719	433	17.356	1.491	898	17.356	1.491	898	17.356	1.491	898	28.337	2.435	1.466	45.051	3.871	2.331		
18	8.877	805	483	18.409	1.670	1.002	18.409	1.670	1.002	18.409	1.670	1.002	30.057	2.726	2.602	47.784	4.334	2.602		
20	9.358	891	533	19.405	1.848	1.106	19.405	1.848	1.106	19.405	1.848	1.106	31.683	3.018	1.806	50.370	4.799	2.872		
22	9.815	978	583	20.352	2.028	1.209	20.352	2.028	1.209	20.352	2.028	1.209	33.230	3.311	1.975	52.829	5.264	3.140		
24	10.251	1.064	633	21.257	2.207	1.314	21.257	2.207	1.314	21.257	2.207	1.314	34.708	3.604	2.145	55.178	5.731	3.411		
26	10.670	1.151	684	22.126	2.388	1.419	22.126	2.388	1.419	22.126	2.388	1.419	36.125	3.899	2.316	57.432	6.198	3.683		
28	11.073	1.238	735	22.961	2.568	1.524	22.961	2.568	1.524	22.961	2.568	1.524	37.489	4.194	2.488	59.601	6.667	3.956		
30	11.462	1.326	785	23.767	2.749	1.628	23.767	2.749	1.628	23.767	2.749	1.628	38.806	4.489	2.658	61.693	7.137	4.227		
32	11.838	1.413	835	24.547	2.931	1.733	24.547	2.931	1.733	24.547	2.931	1.733	40.079	4.785	2.829	63.717	7.608	4.498		
34	12.202	1.501	886	25.303	3.113	1.837	25.303	3.113	1.837	25.303	3.113	1.837	41.312	5.082	3.000	65.679	8.080	4.769		
36	12.556	1.589	936	26.037	3.295	1.941	26.037	3.295	1.941	26.037	3.295	1.941	42.511	5.380	3.170	67.583	8.553	5.039		
38	12.900	1.677	987	26.750	3.478	2.046	26.750	3.478	2.046	26.750	3.478	2.046	43.676	5.678	3.342	69.436	9.028	5.313		
40	13.235	1.765	1.038	27.445	3.661	2.152	27.445	3.661	2.152	27.445	3.661	2.152	44.811	5.977	3.514	71.240	9.503	5.587		

Pressione di taratura P / Set pressure P	DN 65 - do 37			DN 80 - do 46			DN 100 - do 60			DN 125 - do 74			DN 150 - do 92		
	acqua (L) / water	aria (G) / air	vapore d'acqua sat. / sat. steam	acqua (L) / water	aria (G) / air	vapore d'acqua sat. / sat. steam	acqua (L) / water	aria (G) / air	vapore d'acqua sat. / sat. steam	acqua (L) / water	aria (G) / air	vapore d'acqua sat. / sat. steam	acqua (L) / water	aria (G) / air	vapore d'acqua sat. / sat. steam
	a 25°C	a 25°C		a 25°C	a 25°C		a 25°C	a 25°C		a 25°C	a 25°C		a 25°C	a 25°C	
bar	kg/h	kg/h	kg/h	kg/h	kg/h	kg/h	kg/h	kg/h	kg/h	kg/h	kg/h	kg/h	kg/h	kg/h	kg/h
0,25	10.337	352	227	15.978	570	351	27.183	926	597	41.349	1408	909	63.912	2177	1405
0,5	13.536	471	296	20.923	762	457	35.597	1240	778	54.147	1964	1184	83.693	2915	1831
0,75	16.113	573	362	24.905	927	559	42.371	1508	952	64.452	2294	1448	99.621	3546	2239
1	18.330	670	429	28.333	1035	663	48.203	1762	1128	73.323	2861	1716	113.332	4143	2652
1,5	22.451	869	547	34.702	1343	845	59.039	2285	1439	89.805	3476	2189	138.808	5373	3383
2	25.925	1048	663	40.071	1621	1025	68.174	2758	1744	103.701	4195	2653	160.285	6845	4101
2,5	28.985	1262	794	44.801	1952	1227	76.222	3321	2089	115.942	5051	3177	179.207	7808	4911
3	31.752	1.448	908	49.078	2.238	1.404	83.498	3.808	2.389	127.010	5.793	3.634	196.313	8.954	5.618
4	36.665	1.818	1.134	56.671	2.811	1.753	96.416	4.783	2.983	146.660	7.275	4.538	226.687	11.245	7.015
5	40.993	2.189	1.359	63.361	3.384	2.101	107.798	5.758	3.575	163.973	8.759	5.438	253.447	13.539	8.405
6	44.906	2.561	1.583	69.409	3.959	2.447	118.088	6.735	4.163	179.625	10.245	6.333	277.638	15.836	9.788
7	48.504	2.933	1.806	74.971	4.534	2.792	127.550	7.714	4.750	194.019	11.733	7.225	299.886	18.136	11.168
8	51.854	3.305	2.029	80.148	5.109	3.136	136.358	8.693	5.335	207.416	13.223	8.116	320.594	20.439	12.545
9	54.999	3.678	2.251	85.010	5.686	3.479	144.631	9.674	5.920	219.999	14.715	9.005	340.043	22.745	13.919
10	57.975	4.052	2.473	89.609	6.263	3.822	152.455	10.656	6.503	231.901	16.209	9.892	358.439	25.053	15.290
12	63.509	4.800	2.913	98.163	7.419	4.503	167.008	12.623	7.662	254.038	19.202	11.655	392.655	29.679	18.014
14	68.598	5.550	3.354	106.030	8.579	5.184	180.391	14.596	8.820	274.395	22.202	13.416	424.120	34.317	20.737
16	73.336	6.302	3.794	113.352	9.741	5.864	192.848	16.573	9.978	293.344	25.210	15.177	453.408	38.966	23.459
18	77.785	7.056	4.235	120.229	10.906	6.547	204.548	18.556	11.138	311.141	28.226	16.943	480.917	43.627	26.188
20	81.993	7.812	4.676	126.734	12.075	7.227	215.615	20.543	12.296	327.975	31.249	18.704	506.936	48.300	28.911
22	85.996	8.569	5.112	132.921	13.246	7.901	226.141	22.535	13.443	343.986	34.279	20.449	531.684	52.984	31.607
24	89.821	9.329	5.553	138.832	14.419	8.583	236.199	24.532	14.603	359.285	37.317	22.213	555.331	57.679	34.334
26	93.490	10.090	5.995	144.503	15.596	9.267	245.846	26.534	15.767	373.960	40.362	23.983	578.012	62.386	37.070
28	97.020	10.853	6.439	149.959	16.776	9.953	255.129	28.541	16.934	388.080	43.415	25.759	5		