

With Good Reason

Pressure Reducing Valves in Stainless Steel



Made in Germany

Berluto® Armaturen-Gesellschaft mbH
Rhineland Valve Factory



Why stainless steel?

For decades our company is manufacturing a wide range of pressure reducers and float valves. In addition to brass and red bronze we process stainless steel for a certain time for our float valves. So far, however, our pressure reducing valves had been exclusively made in red bronze.

Regular customer inquiries and the increasing demands on technical installations have prompted us to develop and build also pressure reducing valves in high-grade stainless steel.

Our customers appreciate our high level of expertise and the diversity of our range. With this further step we would like to strengthen our know-how and our reputation as a competent and reliable partner for pressure reducers and float valves.

Just standard or also customized special versions?

We offer a wide range of standard valves adapted for a variety of applications. But particularly in recent years we extended our range in line with our customers' individual requirements. In our high-tech production plant we manufacture standard valves in large quantities as well as small series or even single items. To date, we worked out and realised a large number of specific solutions for our customers.

Please contact us if you will not find the appropriate valve in this brochure – we will always find a solution for you!

Why Berluto?

The requirements to pressure reducing valves are most different and individual. A certain feature which is crucial for your special application might be of minor importance for other users. Our brochure shows all new stainless steel series listing the technical key features. This prospectus provides a first overview and might be helpful to find the most appropriate valve type for your purposes.

It may nevertheless be necessary to receive more detailed information. In that case we look forward to receiving your e-mail or you just give us a call – we will gladly answer all your questions and provide personal advice.

You will see: There are many good reasons for a stainless steel pressure reducing valve from Berluto.



... speaking for a Berluto stainless steel pressure reducing valve

- 1 Proven technology made in Germany**
Berluto was founded in 1920 and since that date, nowadays settled in Toenisvorst/Niederrhein, we produce top quality valves made in Germany. Our technology has been proven many thousand times and during the last decades it has been continuously developed and upgraded.
- 2 Durability**
We rely on outstanding quality and produce valves for a permanent long-term use. This robustness and durability is regularly confirmed by our customers who order spare sealing sets for valves which were bought 30 or 40 years ago.
- 3 A modular system with numerous connection types at favourable prices**
With our sophisticated modular system we manage to produce a variety of connection types and combinations. We offer e.g. ANSI flanges, NPT threads, dairy fittings or welded ends. The multitude of combinations enables us to supply a high-quality product at very attractive prices.
- 4 Compact design**
Due to the non-rising stem all our stainless steel pressure reducers are very compact and require little space. The special fine thread allows a high-precise pressure setting.
- 5 Excellent media compatibility**
Needless to say that all standard media may be used. But even aggressive media, fully desalinated water or gases can be used trouble-free with our pressure reducing valves in high-grade stainless steel (material 1.4408).
- 6 Various pressure ranges**
In line with the specific applications we offer different inlet and outlet pressure ranges. On the next page you will find detailed information on this subject.
- 7 High temperature resistance**
The high-quality FKM seals allow permanent media temperatures up to 190°C.
- 8 Inlet pressure relief and ideal flow characteristics**
Fluctuations in the upstream pressure line are a well-known problem. Our valves are pressure-relieved i.e. the set back pressure remains stable and will not be affected by fluctuating inlet pressures. And finally, our stainless steel series has been flow-optimised. The new designed valve body ensures considerably less turbulences of the medium and has a smoother flow rating with reduced noise level.
- 9 Trouble-free maintenance**
Time is money – our stainless steel pressure reducing valves are equipped with a low-maintenance cartridge which is easy to replace with just a few steps. There is no simpler, faster and more cost-efficient way of maintenance.
- 10 Environmentally friendly products**
We are committed to environmental protection. The consumption of energy has been drastically reduced in recent years and we use sustainable materials. However, our biggest asset is the high quality of our products: The long service life, the high reliability of our valves and the reduced maintenance preserve global resources – this is our key contribution to environmental protection.

PN bar	p ₂ bar	Nominal Size	kvs m ³ /h	Design	Internal Thread DRV - Type	Flange DRV - Type
Diaphragm pressure reducer for standard & wide range pressure						
25	1.5 - 6	DN15 - DN50	2.9 - 13	Diaphragm	DRV 702	DRV 802
25	0.5 - 4	DN15 - DN50	2.9 - 13	Diaphragm	DRV 772	DRV 872
25	1.5 - 10	DN15 - DN50	2.9 - 13	Diaphragm	DRV 708	DRV 808
25	0.5 - 9	DN15 - DN50	2.9 - 13	Diaphragm	DRV 778	DRV 878
Pressure reducer with low pressure diaphragm						
25	0.2 - 2	DN15 - DN50	2.9 - 13	Diaphragm	DRV 750	DRV 850
Pressure reducer with high pressure piston						
40	1.5 - 12	DN15 - DN50	2.9 - 13	Piston	DRV 724	DRV 824
40	2.0 - 20	DN15 - DN50	2.9 - 13	Piston	DRV 725	DRV 825



Applications

Our stainless steel valves are particularly suitable for problematic media such as fully desalinated water, aggressive liquids or air and gases.

Characteristics

Due to the pre-pressure relief our valves ensure a stable outlet pressure even with strong fluctuations of the inlet pressure. The removable cartridge simplifies any required maintenance and the strainer filter protects the pressure reducer against damage by solid particles. The high-quality FKM seals tolerate temperatures up to 190°C.

Materials

For our stainless steel valves we solely use top quality materials with a high resistance against a vast number of aggressive media.

Body	stainless steel, V4A, 1.4408
Spring bonnet	stainless steel, V4A, 1.4408
Seals	FKM
Inner parts	stainless steel, V4A, 1.4404

1 | non-rising stem for a small installation height

5 | inlet pressure up to 25 bar or 40 bar

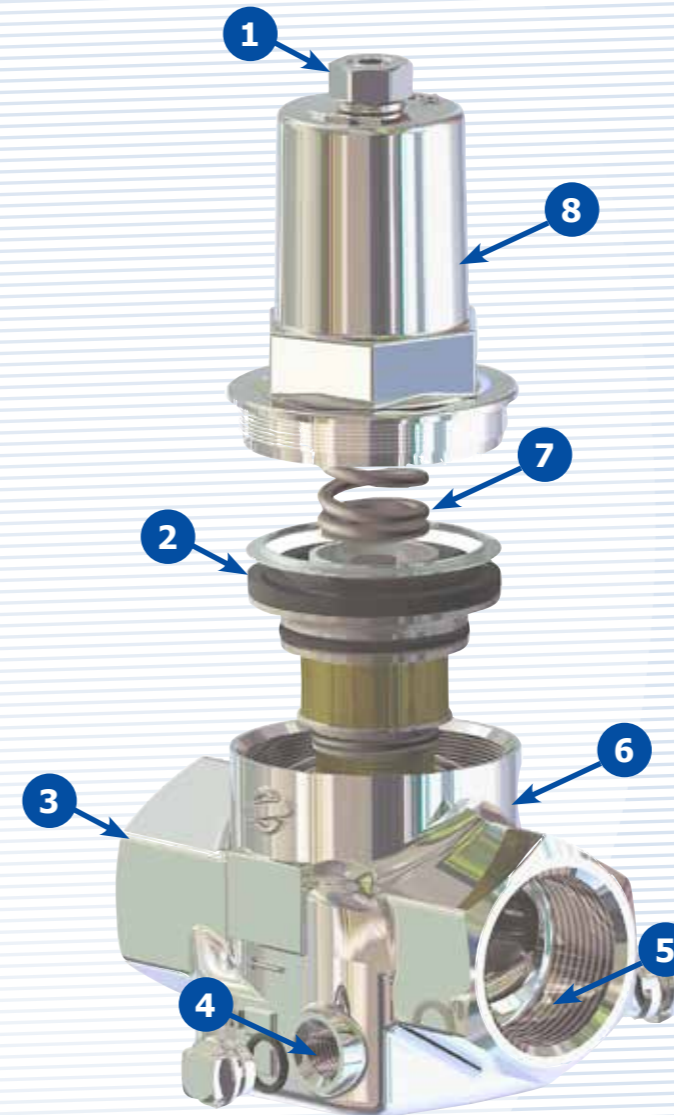

6 | robust valve body made of stainless steel (material 1.4408) for a long service life

2 | high-quality FKM seals for aggressive media and temperatures up to 190°C

7 | various outlet pressure ranges available for optimum adaptation to your application

3 | numerous connection types such as e.g. DIN-, ANSI-, NPT threads and others adapters or fitting elements become superfluous

8 | electropolished surface (optionally available)

4 | manometer connection to control the outlet pressure

9 | removable cartridge for a fast and simple maintenance

10 | integrated strainer filter protects against damage by solid particles

Pressure reducers for standard and wide range pressure with internal thread

Type overview diaphragm pressure reducers with internal thread according to ISO 228

DRV-Type	Max. inlet pressure	Outlet pressure range
DRV 702	25 bar	1.5 - 6 bar
DRV 708	25 bar	1.5 - 10 bar
DRV 772	25 bar	0.5 - 4 bar
DRV 778	25 bar	0.5 - 9 bar



Characteristics

Standard and wide range pressure reducers are adapted for all usual applications with inlet pressures up to 25 bar. Depending on your specific needs you can choose between 4 different outlet pressure ranges.

As standard, the diaphragm controlled pressure reducers are equipped with FKM seals. Optionally, this series is available with NBR seals with KTW- and W270-approval for drinking water applications.

The connection threads correspond to ISO 228, NPT threads are available on request. On the next page you will find an overview of our series with flange connections.

1 fabric reinforced FKM diaphragm for aggressive media and temperatures up to 190°C, optionally with NBR seals (with KTW- and W270-approval for drinking water)

2 Outlet pressures from 0.5 - 10 bar

3 Inlet pressure up to 25 bar

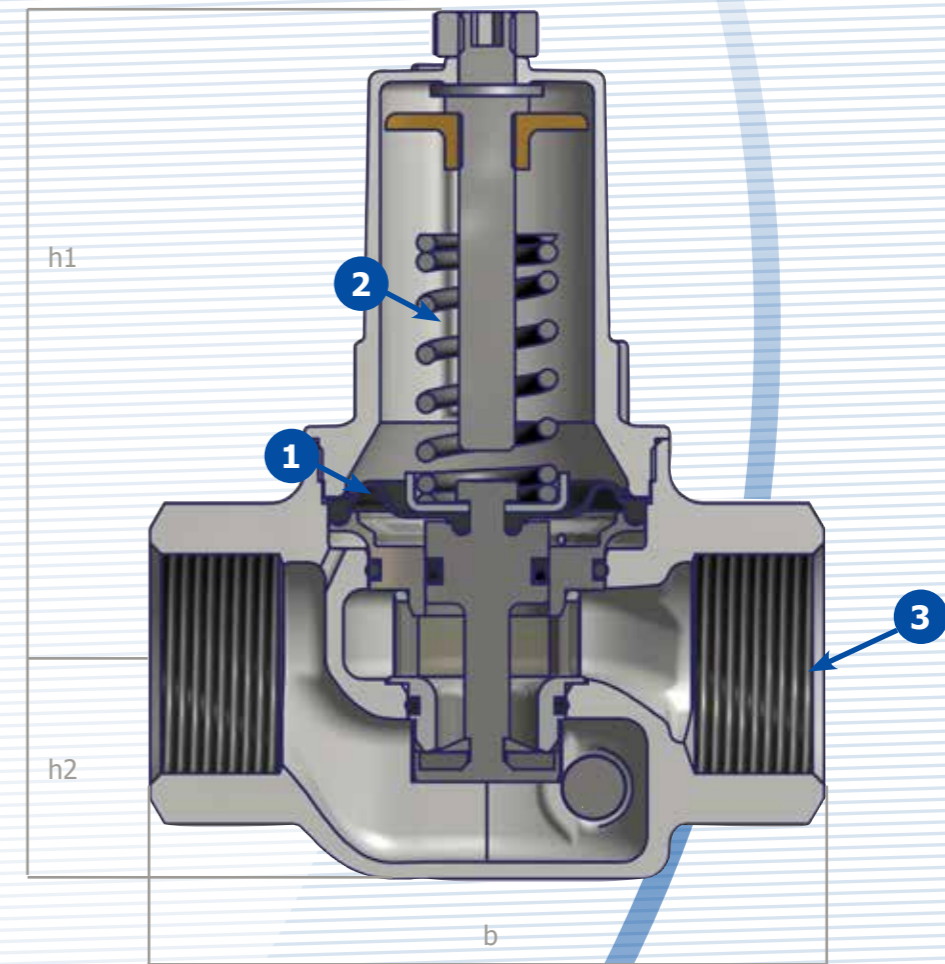

Nominal Size	Connection	Art.no. DRV 702	Art.no. DRV 708	Art.no. DRV 772	Art.no. DRV 778
DN 15	G 1/2"	70202	70802	77202	77802
DN 20	G 3/4"	70203	70803	77203	77803
DN 25	G 1"	70204	70804	77204	77804
DN 32	G 1 1/4"	70205	70805	77205	77805
DN 40	G 1 1/2"	70206	70806	77206	77806
DN 50	G 2"	70207	70807	77207	77807

Nominal Size	Connection	kvs-value in m³/h	Dimension h1 in mm	Dimension h2 in mm	Weight in kg
DN 15	G 1/2"	2.9	118	29	1.3
DN 20	G 3/4"	3.9	118	29	1.3
DN 25	G 1"	5.4	118	39	2.0
DN 32	G 1 1/4"	6.1	118	39	2.0
DN 40	G 1 1/2"	9	219	37	5.4
DN 50	G 2"	13	219	37	5.3

Pressure reducers for standard and wide range pressure with flanges

Type overview diaphragm pressure reducers with flanges according to DIN EN 1092

DRV-Type	Max. inlet pressure	Outlet pressure range
DRV 802	25 bar	1.5 - 6 bar
DRV 808	25 bar	1.5 - 10 bar
DRV 872	25 bar	0.5 - 4 bar
DRV 878	25 bar	0.5 - 9 bar



Characteristics

Standard and wide range pressure reducers are adapted for all usual applications with inlet pressures up to 25 bar. Depending on your specific needs you can choose between 4 different outlet pressure ranges.

As standard, the diaphragm controlled pressure reducers are equipped with FKM seals. Optionally, this series is available with NBR seals with KTW- and W270-approval for drinking water applications.

The flanges correspond to DIN EN 1092, ANSI or JIS flanges are available on request.

Nominal Size	Art.no. DRV 802	Art.no. DRV 808	Art.no. DRV 872	Art.no. DRV 878
DN 15	80202	80802	87202	87802
DN 20	80203	80803	87203	87803
DN 25	80204	80804	87204	87804
DN 32	80205	80805	87205	87805
DN 40	80206	80806	87206	87806
DN 50	80207	80807	87207	87807

1 fabric reinforced FKM diaphragm for aggressive media and temperatures up to 190°C, optionally with NBR seals (with KTW- and W270-approval for drinking water)

2 Outlet pressures from 0.5 - 10 bar

3 Inlet pressure up to 25 bar

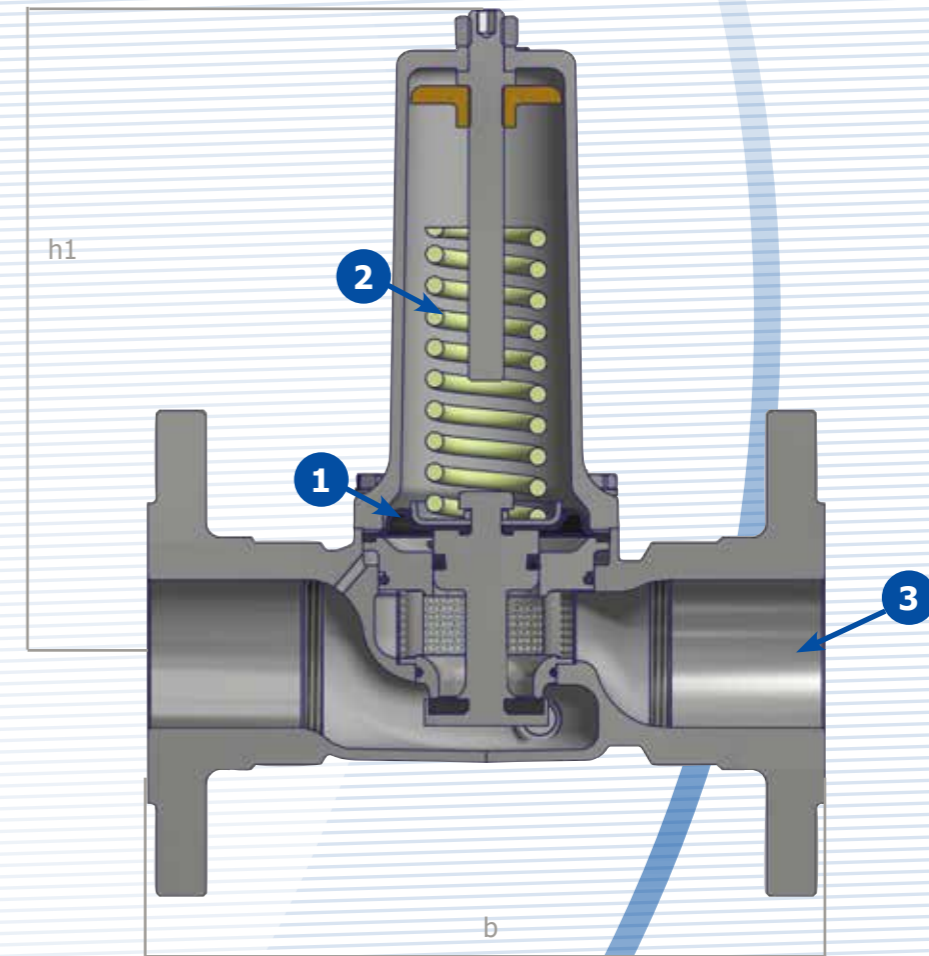

Nominal Size	kvs-value in m³/h	Dimension b in mm	Dimension h1 in mm	Flange Ø in mm	Weight in kg
DN 15	2.9	130	118	95	1.3
DN 20	3.9	150	118	105	1.3
DN 25	5.4	160	118	115	2.0
DN 32	6.1	180	118	140	2.0
DN 40	9	200	219	150	5.4
DN 50	13	230	219	165	5.3

Pressure reducers for low pressure with internal thread and flanges

Type overview pressure reducers for low pressure with internal thread according to ISO 228 and flanges according to DIN EN 1092

DRV-Type	Connection	Max. inlet pressure	Outlet pressure range
DRV 750	Internal Thread	25 bar	0.2 - 2 bar
DRV 850	Flange	25 bar	0.2 - 2 bar



Characteristics

Low pressure reducers are adapted for applications with inlet pressures up to 25 bar combined with low outlet pressures from 0.2 to 2 bar.

With the help of the enlarged control diaphragm the outlet pressure can be set sensitively and with high accuracy.

These low pressure versions are ideally suited for critical applications, whenever low pressures are required or sensitive devices will be installed downstream.

As standard, all low pressure reducers are available with internal thread according to ISO 228 and with flanges as per DIN EN 1092. On request, connection types such as ANSI, JIS, NPT or welding ends are deliverable.

Nominal Size	Art.no. DRV 750	Art.no. DRV 850
DN 15	75002	85002
DN 20	75003	85003
DN 25	75004	85004
DN 32	75005	85005
DN 40	75006	85006
DN 50	75007	85007

1 | enlarged control diaphragm for a sensitive control

2 | Outlet pressure from 0.2 - 2 bar

3 | Inlet pressure up to 25 bar

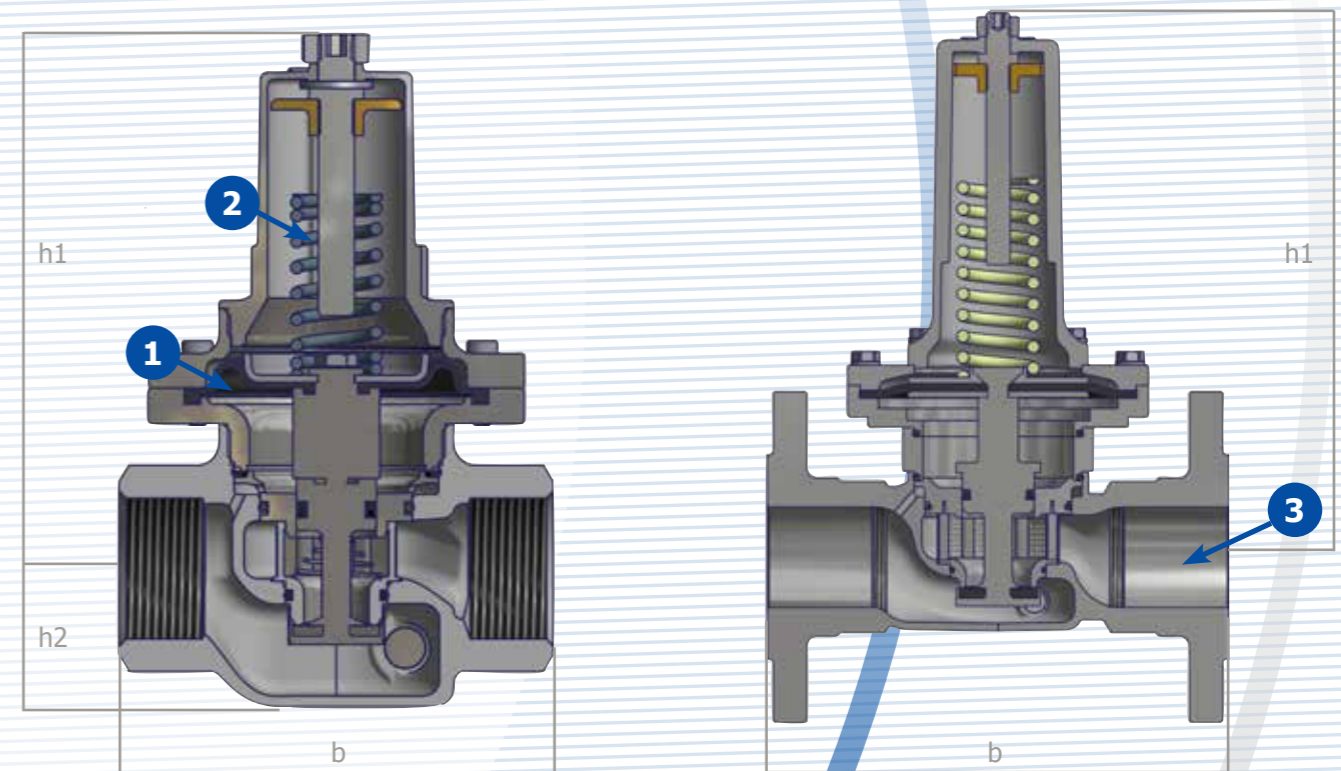

Nominal Size	kvs-value in m³/h	Dimension h1 in mm	DRV 750			DRV 850		
			Dimension h2 in mm	Dimension b in mm	Weight in kg	Dimension b in mm	Flange Ø in mm	Weight in kg
DN 15	2.9	137	29	95	1.7	130	95	3.2
DN 20	3.9	137	29	95	1.6	150	105	3.9
DN 25	5.4	150	39	110	3.1	160	115	5.9
DN 32	6.1	150	39	120	3.0	180	140	7.3
DN 40	9	269	37	150	9.3	200	150	13.7
DN 50	13	269	37	160	9.1	230	165	15.4

Pressure reducers for high pressure with internal thread and flanges

Type overview pressure reducers for high pressure with internal thread according to ISO 228 and flanges according to DIN EN 1092

DRV-Type	Connection	Max. inlet pressure	Outlet pressure range
DRV 724	Internal Thread	40 bar	1.5 - 12 bar
DRV 824	Flange	40 bar	1.5 - 12 bar
DRV 725	Internal Thread	40 bar	2 - 20 bar
DRV 825	Flange	40 bar	2 - 20 bar



Characteristics

Piston-type pressure reducers for high pressure are extremely robust. With a maximum inlet pressure range up to 40 bar and an outlet pressure range up to 20 bar this series is ideally suited for numerous demanding applications.

Due to the robust piston design these types react less sensitive to pressure shocks than diaphragm pressure reducers.

The missing diaphragm reduces the seals contact surface of piston-type pressure reducers. That is why this valve type is perfectly adapted for applications with highly aggressive media.

As standard, all high pressure reducers are available with internal thread according to ISO 228 and with flanges as per DIN EN 1092. On request, connection types such as ANSI, JIS, NPT or welding ends are deliverable.

Nominal Size	Art.no. DRV 724	Art.no. DRV 824	Art.no. DRV 725	Art.no. DRV 825
DN 15	72402	82402	72502	82502
DN 20	72403	82403	72503	82503
DN 25	72404	82404	72504	82504
DN 32	72405	82405	72505	82505
DN 40	72406	82406	72506	82506
DN 50	72407	82407	72507	82507

1 | robust piston design therefore less sensitive to pressure shocks

2 | high outlet pressure range outlet pressures from 1.5 – 20 bar

3 | Inlet pressure up to 40 bar

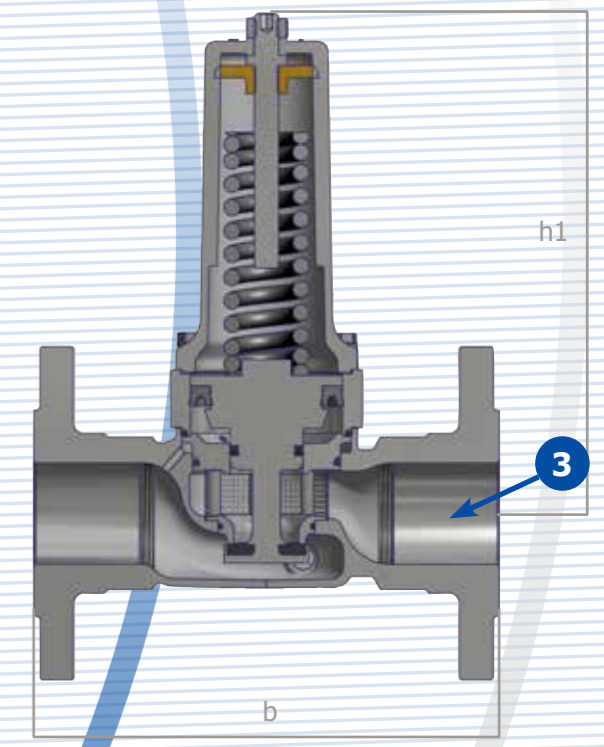
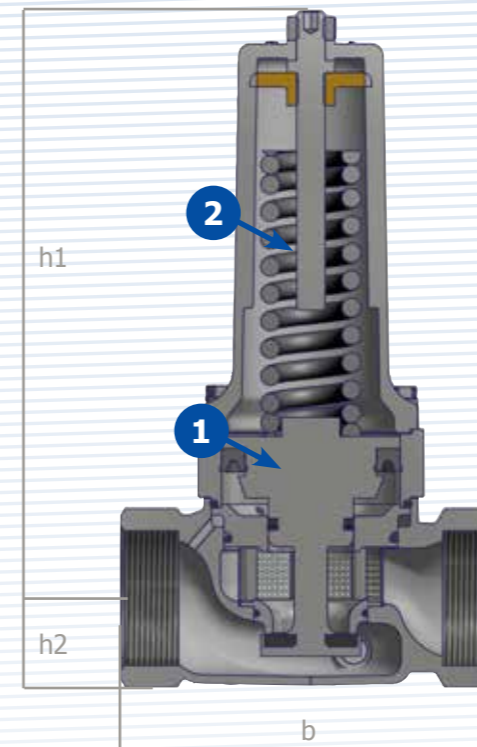

Nominal Size	kvs-value in m³/h	Dimension h1 in mm	DRV 724 & DRV 725			DRV 824 & DRV 825		
			Dimension h2 in mm	Dimension b in mm	Weight in kg	Dimension b in mm	Flange Ø in mm	Weight in kg
DN 15	2.9	136	29	95	1.7	130	95	3.2
DN 20	3.9	136	29	95	1.6	150	105	3.9
DN 25	5.4	137	39	110	2.5	160	115	5.3
DN 32	6.1	137	39	120	2.4	180	140	6.6
DN 40	9	247	37	150	6.8	200	150	11.2
DN 50	13	247	37	160	6.7	230	165	13.0

How to choose the right pressure reducer for my application?

General determination of the application

For the correct dimensioning of a pressure reducer first of all the maximum flow rate with satisfactory regulating performance has to be stipulated. This rate results from the relation of smallest possible inlet pressure and the required outlet pressure that is to be regulated. Moreover, the medium density (e.g. water 1.000 kg/m³, air 1,293 kg/m³) must be known. And finally the temperature is decisive for media like air and gases.

If the required nominal size of the pipeline and the valves' nominal size determined by the kvs-calculation differ considerably, then the nominal size of the pressure reducer may vary 1 to 2 sizes from the nominal size of the pipeline; in this case a sufficient inlet and outlet section before and behind the valve (with nominal size equal to the pressure reducer) is recommended (length approx. 10 times nominal size)

Calculation of the kvs-value

Knowing the application data (lowest inlet pressure, outlet pressure to be regulated, max. flow rate, density and temperature of the medium) the required kv-value will be calculated (this can easily be done with our kv-value calculator under <http://www.berluto.com/service-area/kv-cv-value-calculator>). The calculator indicates the minimum kv-value (kv) as well as the kv-set value (kvs) of a certain pressure reducer for the required application. Having obtained these values, the matching pressure reducer can be chosen from our type overview (column kvs). Starting from the minimum kv-value, the pressure reducer would be completely opened with the specified discharge (i.e. at the end of the setting range). An additional raise of the discharge would result in a falling outlet pressure. If a certain reserve for the discharge rate is desired, the valve selection should base on the kvs-value which is 30% above the minimum value (kv); with this flow rate the valve works in an optimum range. On the other hand, with regard to the kvs-value, the pressure reducer should not be oversized, this will lead to a functioning below the optimum range. Generally, the best performance will be achieved in the range of 10% to 70% of the kvs-value.

Selection of the setting range

For an optimum regulating precision the setting range for the outlet pressure should be settled in the upper part of the scale i.e. the required outlet pressure should be at around 70% to 90% of the setting range. For instance, for an outlet pressure of 1.4 bar a valve with a setting range from 0.2 to 2 bar is better suited than a pressure reducer with a setting range from 0.5 to 4 bar.

Example

Inlet pressure: 10 bar
 Outlet pressure: 4 bar
 Flow rate: 15 m³/h
 Medium: water
 Temperature: 20 °C

For this example the minimum kv-value would be 6.1 m³/h and the kvs-value would be 8 m³/h. According to this calculation and if no further requirements are specified (e.g. nominal size of the pipeline) the correct valve for this pressure range would be type DRV 702 DN32 (as minimum size) or type DRV 702 DN40. Providing that the maximum velocity must not exceed 2 m/s, the optimum nominal size for a flow rate of 15 m³/h will be DN50. In general, the nominal size of the pipeline may exceed the valves' nominal size by 2 stages. For the example cited both types with nominal sizes DN32 and DN40 might be chosen, as well as type DN50 which would be the optimum choice for this pipeline (kvs-value = 13m³/h -> the desired kvs-value of 8 m³/h is at 62% of the valve performance)

Calculation of the nominal size

Provided that the pipeline is not yet installed, at first one will base the selection on the nominal size arising from the kvs-calculation of the pressure reducer (as described above). In case that the pipeline exists already one tends to choose a pressure reducer with the nominal size equal to the pipeline. However, when choosing the pipeline it is important to ensure that the installation-specific maximum flow velocity will not be exceeded. This might cause an augmented component loading, pressure loss and a significant noise level. For liquids the flow velocity is calculated with 2 m/s on average (maximum 5 m/s), for air and gases with 10 to 20 m/s. .

Remark

Please make sure that the pressure reducer will not be oversized (as a minimum the required kvs-value should be around 10% of the valves' kvs-value). An oversizing might affect the function significantly.



Company history

On 31th of July, the plumber Jean Bergner received the German patent for his invention of a particularly robust and reliable construction of a float valve.

In 1920, Bergner founded, in cooperation with the merchant Ludwig and the plumber Toeller, the company Berluto. 4 years later, in 1924, the "Berluto Armaturen AG" was established under the chairmanship of August Bender and in 1953 the company was transformed into today's "Berluto Armaturen GmbH". To date the business is run in the third generation by descendants of the founder.



Today

This day, Berluto Armaturen GmbH is located in an advanced development and manufacturing site in Toenisvorst, Germany. Computer-aided development processes and CNC-machining centers with CAD/CAM connection ensure a flexible production with high precision and short processing times. This allows a production of large valve series as well as custom-made special valves in the well-known high quality made in Germany by Berluto.



We would be pleased to welcome you as our new customer

In this brochure you will find just a small selection of our entire product range. For reasons of space we are not able to show all variations and special versions in this prospectus. If you do not find the adequate valve for your application, please do not hesitate to contact us by phone, by email, or by fax. We will do our best to offer the optimum solution for your purposes. We look forward to hear from you soon.

With good reason

Our program



| Pressure reducers in stainless steel



| Pressure reducers in red bronze



| Float valves in stainless steel

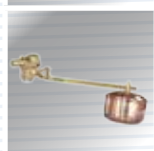

| Float valves in red bronze and brass



| Safety valves in red bronze and brass



| Dirt traps in red bronze and stainless steel



Berluto® Armaturen-Gesellschaft mbH
P.O. Box 11 52 • D-47907 Toenisvorst • Germany
Tempelsweg 16 • D-47918 Toenisvorst • Germany

Phone: +49 - (0)2151 - 7038-0
Fax: +49 - (0)2151 - 7007 63

eMail: info@berluto.de
www.berluto.de