

# Pressure & Flame Protection



**Bailey**

*Safety & Regulating Valves*

# Bailey

## G4 PILOT PRESSURE REDUCING VALVES



## DA SERIES PRESSURE REDUCING VALVES

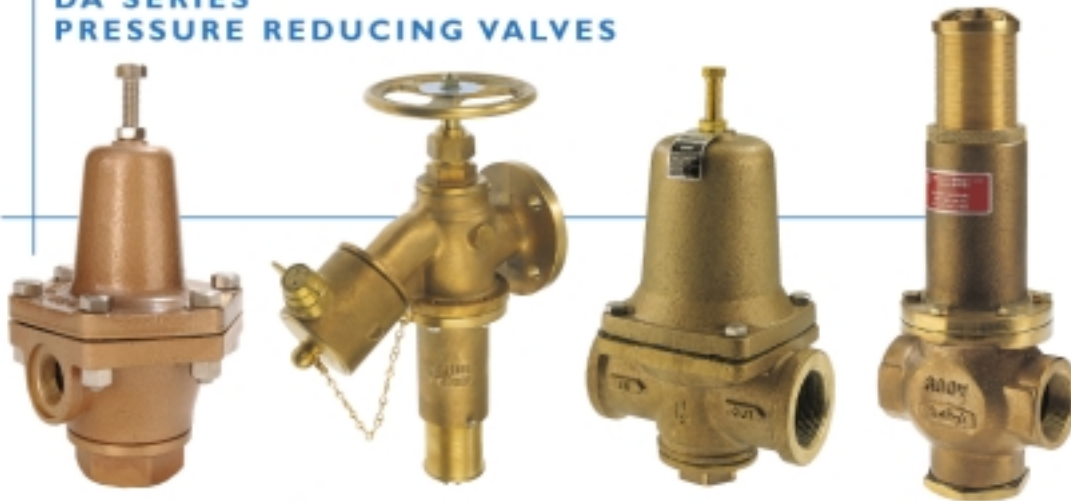

## 700 SERIES SAFETY RELIEF VALVES



## 480/490 AND 616D SAFETY RELIEF VALVES



# Bailey

## Safety and Regulating Valves

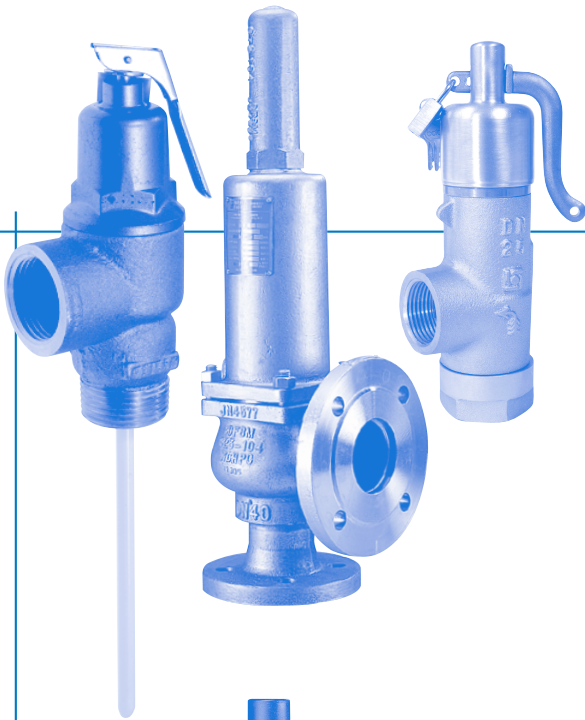

### SAFETY RELIEF VALVES

Bailey safety relief valves offer a broad spectrum of protection against over-pressure for vital services such as steam, air, gases, water and process fluids.



### PRESSURE REDUCING VALVES

Bailey pressure reducing valves offer comprehensive pressure regulation for key services, fire hose and pressure systems using steam, air, water, hot water and fine industrial gases.



### SIGHT GLASSES

A range of sight glasses are available for visual inspection of key processes.

# Bailey

## The logical choice

Wherever demanding applications exist you will find Bailey valves, from industrial and commercial to domestic and fire fighting.

Bailey valves are used in the construction of hotels, high-rise buildings, hospitals, textile, paper and steel mills, rubber, food, drink, chemical and pharmaceutical processes, off-shore oil and gas platforms, floating production storage and off-loading (FPSO) vessels. In fact, anywhere boilers, compressors or pumps produce high-pressure service media for use on multiple low-pressure applications.

Global legislation covering all pressure equipment and systems requires regular inspection of plant, pipework and safety provisions. Bailey valves have demonstrated proven reliability over many years and require minimal maintenance.

A policy of continuous improvement assures that Bailey valves will always meet current legislative requirements and of course provide exceptional reliability and performance. Bailey's design service can help to specify the most appropriate size and type of valve for any specific application, with the ability to include special modifications where necessary.

By choosing Bailey, quality, professional advice and proven performance are assured - all delivered through an extensive world-wide network of distributors.

Should a valve change-out be required at short notice, ex-stock availability of most standard valves via our extensive distribution network ensures minimal plant downtime and maximum protection.

Experience and focus on customer services make Bailey the logical choice of supplier for valves to reduce or limit pressure in pipework, boilers and vessels - across a wide range of applications.

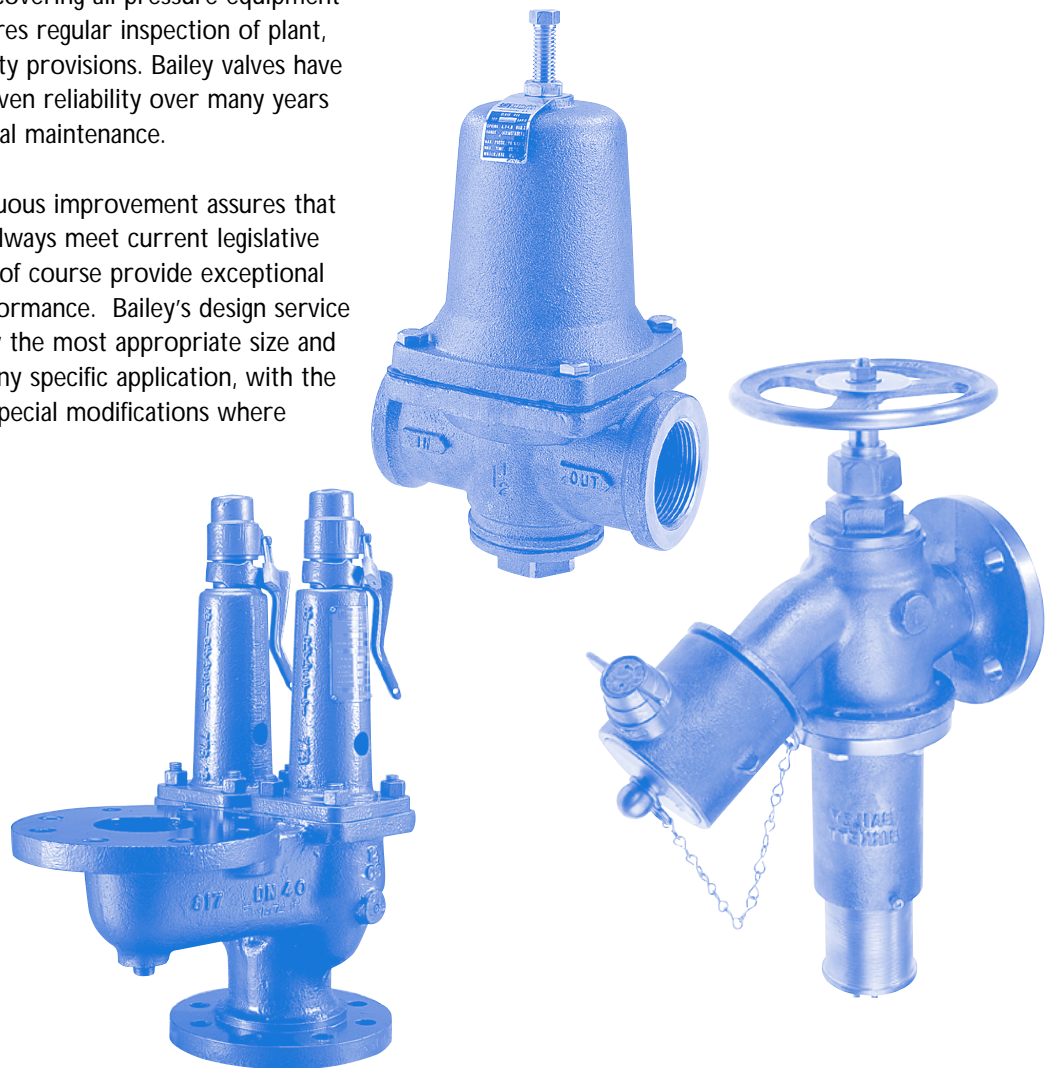

## CONTENTS

### Page Safety Relief Valves

5	Introduction
6	Definitions
7	Application Table
8	Installation Guidelines
9-10	707
11-12	716
13-14	716H
15-16	716T
17-18	746
19-20	756
21-22	766
23-24	776
25-26	480-490
27-28	616D

### Page Pressure Reducing Valves

29	Introduction and Application Table
----	------------------------------------

#### G4 - Pilot Operated Reducing Valve

31	Remote Pressure Sensing
32	Low Pressure (less than 0.35 Barg)
32	Gas and Oxygen Duties
33-34	Drawing, Parts List and Materials
35	Technical Specification
36	Dimensions
37-38	Installations
39	Setting
40	Sizing
41	Sizing Example
41	Spares
42-44	Surplus/Maintaining Valves

#### DA - Direct Acting Reducing Valves

45-46	Class T
47-48	Class TH
49-50	Bailey B
51-52	C10
53-54	Class F

#### Installation

55	Installation of PRVs
56	Rise to Dead End
56	Setting PRVs

### Page Associated Products

57-58	1001S Sight Glass
-------	-------------------

### Page Capacity Charts/Sizing

60-61	Safety Relief Valves Air Capacity Charts
62-63	Safety Relief Valves Saturated Steam Capacity Charts
64-65	Safety Relief Valves Water Capacity Charts
66-67	Safety Relief Valves Hot Water Capacity Charts
68	G4 Dry Saturated Steam Capacity Chart
69	G4 Air Capacity Charts
70-71	G4 Pipe Sizing Chart
72-73	C10 and Class T Air Capacity Charts/Sizing
74-75	C10 and Class T/TH Water Capacity Charts/Sizing
76	Bailey B Saturated Steam Capacity Charts/Sizing
77	Class F Sizing

### Page Spring Selection Charts

79	480/490 and 707 Spring Selection Charts
80	716 Spring Selection Chart
81	Pressure Reducing Valves Spring Selection Charts

# Safety Relief Valves

## INTRODUCTION

The effects of exceeding safe pressure levels in an unprotected pressure vessel or system, can have catastrophic effects on both plant and personnel.

Safety relief valves should be used to protect any pressurised system from the effects of exceeding its design pressure limit.

A safety relief valve is designed to automatically discharge gas, vapour or liquid from any pressure containing system, preventing a predetermined safe pressure being exceeded, and protecting plant and personnel.

### Safety Valve

A valve which automatically discharges gases and vapours so as to prevent a predetermined safe pressure being exceeded. It is characterised by a rapid full opening action and is used for steam, gases or vapour service.

### Relief Valve

A valve which automatically discharges fluid, usually liquid, when a predetermined upstream pressure is exceeded. The term is commonly used for pressure relieving valves in which the lift is proportional to the increase in pressure above the set pressure.

### Safety Relief Valve

A valve which will automatically discharge gases, vapours or liquids, to prevent a predetermined safe pressure being exceeded. It is characterised by a rapid opening action.

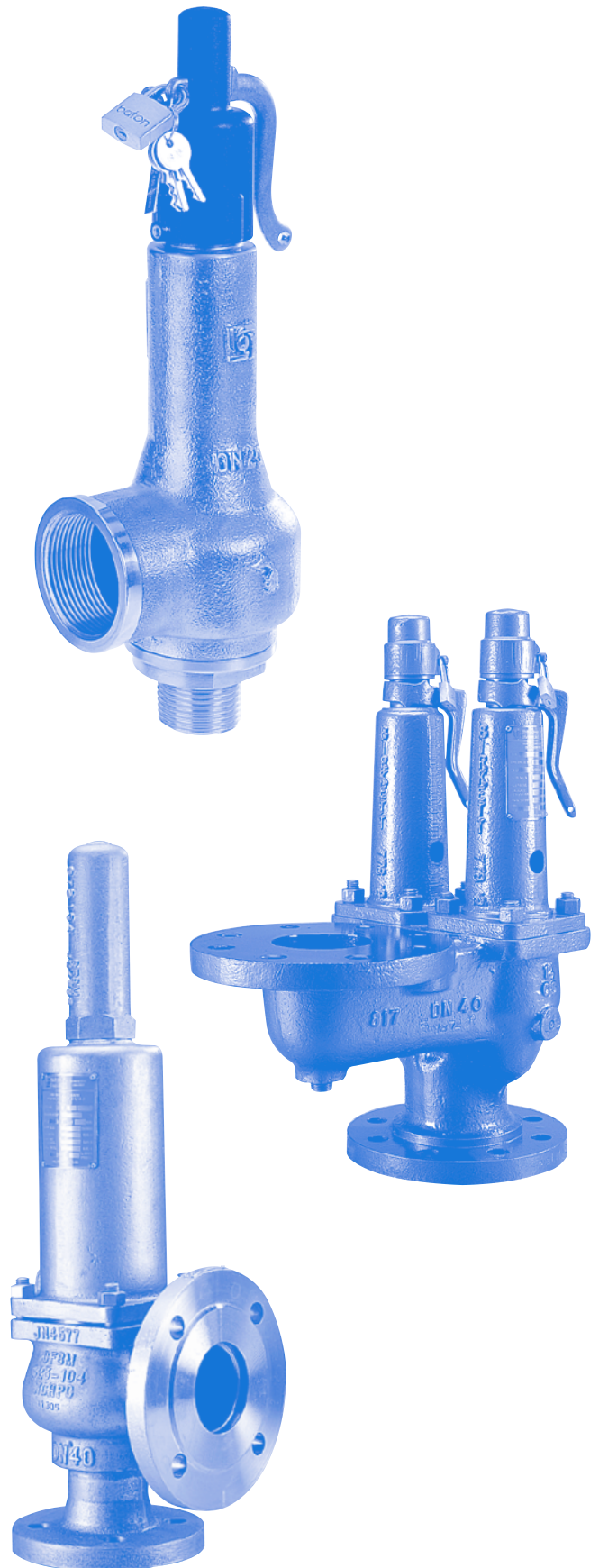

## DEFINITIONS

### Set Pressure

The pressure measured at the valve inlet at which a safety relief valve should commence to lift under service conditions.

### Overpressure

The pressure increase above set pressure at the valve inlet at which the discharge capacity is attained. Usually expressed as a percentage of set pressure.

### Accumulation

The pressure increase over a maximum safe working pressure of the vessel or system when the safety relief valve is discharging at its rated capacity is called accumulation. The term refers to the vessel or system to be protected and not to the valve. Accumulation is the same as over-pressure when the valve is set at the design pressure of the vessel.

### Re-Seat Pressure

The pressure measured at the valve inlet at which the safety relief valve closes.

### Blow-Down

The difference between the set pressure and the re-seating pressure expressed as a percentage of the set pressure or as a pressure difference.

### Simmer

The pressure zone between the valve set pressure and the popping pressure. In this pressure zone the valve is only slightly open and therefore discharging a small percentage of its rated capacity.

### Popping Pressure

The pressure at which the valve disc rapidly moves from a slightly open (simmer) position to a practically full open position.

### Superimposed Back Pressure

Pressure higher than atmosphere in the safety relief valve outlet. This may result from discharge into the common disposal system of other safety relief valves or devices, or as a result of a specific design requirement. Back pressure can be either constant or variable depending on the operating conditions.

### Built Up Back Pressure

The pressure existing at the outlet of a safety relief valve caused by flow through the valve into the disposal system.

### Differential Set Pressure

This is the difference between the set pressure and the constant superimposed back pressure. It is applicable only when a conventional type safety relief valve is used to discharge against constant superimposed back pressure. (It is the pressure at which the safety valve is set at on the test bench without back pressure.)

### Cold Differential Set Pressure

The pressure at which a safety relief valve, intended for high temperature service, is set on a test rig using a test fluid at ambient temperature. The cold differential test pressure will be higher than the set pressure, in order to compensate for the effect of elevated temperature on the valve. Refer to table on page 8.

### Valve Lift

The actual travel of the valve disc away from the seat when the valve is relieving.

### Discharge Capacity

Actual rate of discharge of service media, which can be expressed in mass flow or volumetric terms.

### Equivalent Capacity

Calculated mass or volumetric flow rate of the valve of a given test fluid. The fluids commonly used for test purposes are steam, air and water.

## PRESSURE TERM RELATIONSHIP

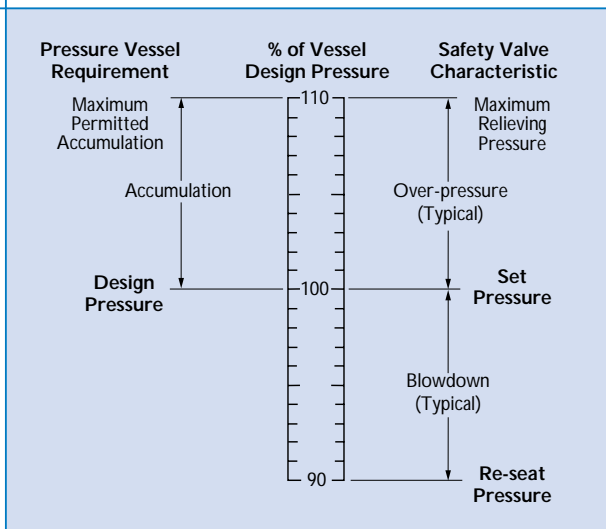

Note: System operating pressure must always be less than the re-seat pressure.

## SAFETY RELIEF VALVE - APPLICATIONS

Application	Medium	Safety Relief Valve Type
Vented boilers Un-vented boilers	Hot Water	707 716 746 716T
Boiler, pipeline and vessel protection	Steam	707/716 746 756/766
Compressor pipeline and receiver protection	Air	707 716 746
Pipeline and vessel protection	Cold Water	707 716 746
Pump protection	Liquids	480/485
Process pipeline, pump and vessel protection	Process/Corrosive Liquids	716 Stainless steel 746 Stainless steel 490 Stainless steel
Clean steam and hygienic environments	Steam and Gases	716 Stainless steel 746 Stainless steel
Pipework, tank and equipment protection	Cryogenic Gases	776
Pipework, tank and equipment protection	Cold & Fine Gases	716 776
Blowers, bulk transfer, tank duty, road/rail transfers	Air	616D

The selection of figure number for each application depends on:  
Pressure - capacity - material - temperature - fluid - connection required.



## INSTALLATION

Safety Relief Valves should always be installed in an upright position with their spring chamber vertical. All packing materials should be removed from the valve connections prior to installation.

### Pressure Vessels

When fitting a Safety Relief Valve onto pressure vessels, the inlet connection pipe should be as short as possible and the bore should be at least equivalent to the nominal bore size of the valve.

The pressure drop between the vessel and the valve should be no more than 3% at rated capacity.

A pressure-tight dome should be specified when:

- 1) A back pressure must be contained within the relieving system.
- 2) A head of liquid is built up within the valve body and consequently needs to be contained.
- 3) The relieving medium is toxic, corrosive or environmentally unfriendly.

### Pipelines

When fitting a Safety Relief Valve into a pipeline, the inlet connecting pipe leading from the main pipeline to the Safety Relief Valve should be as short as possible, so that the inlet pressure drop is no more than 3% of rated capacity.

In addition, it is advised that the Safety Relief Valve is placed a sufficient distance downstream of the pressure source. This will protect the valve from the adverse effects of pressure pulsations.

### Discharge Pipelines

These should be equal to or larger than the valve outlet, with adequate supports, minimum number of bends and overall length. Unless balanced bellows valves are installed, the maximum built up backpressure should not exceed 10% of the set pressure, although the 746, 756 and the 766 can handle higher back pressure if required. Steam service valves should be adequately drained.

Alignment of the discharge or drain should present no risk to persons or property. Protection from the collection of rainwater or condensation in the discharge pipe is advisable.

### System Cleansing

It is essential that new installations are fully flushed and all debris removed prior to installing the valve as serious damage can be caused to valve seats, resulting in subsequent leakage.

### Pressure Adjustment

Every valve is fitted with a suitable spring and tested before leaving the factory. Valves can be preset on request but to alter the set pressure, the adjusting screw, when viewed from the top, should be screwed downwards in a clockwise direction to increase the set pressure and upwards in an anti-clockwise direction to decrease it. Set pressure adjustment must be carried out by experienced and approved personnel. Any change in set pressure must be within the range of the existing spring, if it exceeds the range, a new spring will be required. The cap lead seal must be re-made after any adjustment to the set pressure.

### Blowdown Adjustment

(756 & 766 valves only)

The blowdown ring (part no. 8) is set before the valve leaves the factory and normally no further adjustment will be necessary. However, if the reseating pressure has to be altered in service, the blowdown ring should be screwed (downwards) clockwise to raise the re-seat, popping and simmer pressures. If the blowdown ring is screwed (upwards) anti-clockwise the re-seat, popping and simmer pressures will lower. When re-inserting the setting screw (part no 9.) it should always be placed to engage a slot in the blowdown ring. The standard blowdown is 5% for 756 and 10% for 766 valves (minimum 0.3 Barg for both valve types).

For recommended settings, please contact our technical sales office who will be pleased to help.

## COLD DIFFERENTIAL TEST PRESSURE

When setting a valve intended for use at high temperature on a test rig using a test fluid at ambient temperatures, it is necessary to set the valve at a slightly higher pressure, so that it will open at the correct set pressure under operating conditions. The necessary allowance is shown in the following table.

Operating temperature	Increase in set pressure at ambient temperature
Up to 121°C	None
122°C to 316°C	1%
317°C to 427°C	2%

# 707 Safety Relief Valve



## DESIGN

The Bailey 707 Safety Relief Valve encompasses a top guided design, combining an unobstructed seat bore with high lift capability. This bronze bodied valve can be supplied with a resilient or metal trim with a choice of screwed and flanged connections.

The Bailey 707 is certified to BS EN 4126 Part 1 (BS6759 pt 1:2:3) and is suitable for duty on air/gas, steam/hot water (above 100°C) and process liquid.

Test levers are available for inline safety checking, alternatively a sealed dome can be supplied for service conditions requiring a pressure tight seal on the discharge side, eg. liquid service with enclosed discharge.

## TECHNICAL SPECIFICATION

### Approvals

BS EN ISO 4126 Part 1 (SAFED)  
Pressure Equipment Directive (PED)  
ISO 9001:2008  
Water Regulation Advisory Scheme (WRAS)

### Materials

Body - Bronze from -20 to 224°C  
Trim - St.St/EPDM from -20 to 95°C  
- St.St/Aflas from -20 to 200°C  
- St.St. from -20 to 224°C

### Size Range

Size	Orifice mm <sup>2</sup>	Min (Barg) Pressure	Max (Barg) Pressure
DN15 (1/2")	126	0.3	24.0
DN20 (3/4")	364	0.3	24.0
DN25 (1")	481	0.3	24.0
DN32 (1 1/4")	791	0.3	24.0
DN40 (1 1/2")	1240	0.3	24.0
DN50 (2")	1943	0.3	24.0

### Performance

	Kdr	Over pressure	Blow down
Steam	0.173	10%	15%*
Hot water ‡	0.173	10%	15%*
Air / Gas	0.173	10%	15%*
Liquid	0.149	10%	20%*†

\* or 0.3 Barg min † or 0.6 Barg min ‡ above 100°C

### Maximum Back Pressure

Barg	5.5
Constant	80%
Built-up	10%
Variable	0%

(Total % must not exceed Barg shown)

### Connections

Screwed Female In x Screwed Female Out  
Screwed Male In x Screwed Female Out  
Flanged In x Flanged Out

### Construction

Top Guided / High Lift

### Cap Options

Open lever  
Screw-on pressure tight dome

### Sizing

Refer to Capacity Charts (page 60-67)

### Spring Selection

Refer to Spring Selection Chart (page 79)

## PARTS

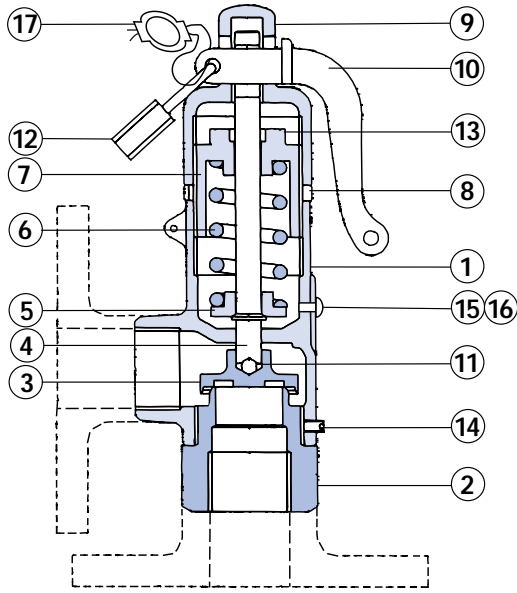

ITEM	PART	MATERIAL
1	Body	Bronze
2	Seat	Bronze
3*	Disc	Stainless Steel/
	Assembly	EPDM/Aflas
4	Spindle	Stainless Steel
5	Spring Cap	Stainless Steel
6*	Spring	Chrome Alloy
7	Adjusting Screw	Bronze
8	Locking Ring	Bronze
9	Dome	Bronze
10	Lever	Bronze
11*	Ball	Stainless Steel
12	Padlock	Brass
13	Bush	PTFE
14	Pinning Screw	Steel
15	Nameplate	Aluminium
16	Nameplate Screw	Steel
17	Lead & Wire Seal	Lead & Stainless Steel

Note:

\* Recommended spares; available from Safety Systems UK Ltd.  
Recommended inspection every 12 months.

## DIMENSIONS

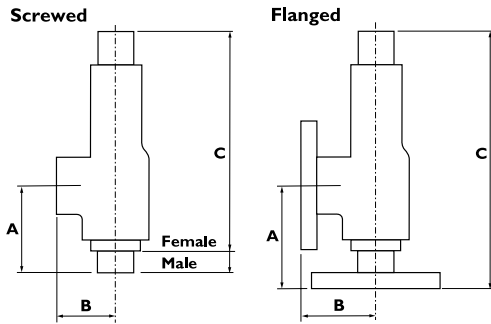

Valve Type	Valve Size	Inlet	Outlet	A	B	C	C	Weight
				mm	mm	Dome	Lever	(kg)
Male x Female	DN15	1/2"	1/2"	59	29	130	152	0.5
	DN20	3/4"	3/4"	65	37	159	181	1.6
	DN25	1"	1"	78	40	185	208	2.0
	DN32	1 1/4"	1 1/4"	89	48	205	237	3.5
	DN40	1 1/2"	1 1/2"	95	56	245	277	5.0
	DN50	2"	2"	109	71	298	333	7.0
Female x Female	DN15	1/2"	1/2"	40	29	111	133	0.6
	DN20	3/4"	3/4"	46	37	140	162	1.0
	DN25	1"	1"	56	40	163	186	1.5
	DN32	1 1/4"	1 1/4"	67	48	183	215	3.0
	DN40	1 1/2"	1 1/2"	67	56	216	249	4.5
	DN50	2"	2"	79	71	268	303	6.0
Flanged x Flanged	DN20	3/4"	3/4"	70	62	164	187	2.0
	DN25	1"	1"	71	73	179	202	3.0
	DN32	1 1/4"	1 1/4"	90	81	206	239	4.5
	DN40	1 1/2"	1 1/2"	94	89	243	276	6.0
	DN50	2"	2"	110	108	298	333	9.0

## FIGURE NUMBERING

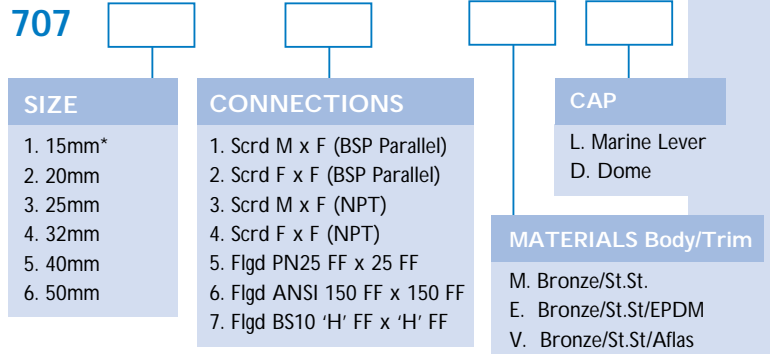

\* For screwed only.

# 716 Safety Relief Valve



## DESIGN

The 716 Safety Relief Valve combines a top guided, unobstructed seat bore with full lift capability to provide maximum discharge capability.

Positive reseating is achieved with freely pivoting EPDM discs for gas, hot water and other liquid duties up to 150°C. Optional Aflas soft seats increase the range to 200°C. Precision lapped stainless steel trim gives positive re-seating for steam duty at higher temperatures. Fitted with a test lever for inline safety checking, or alternatively with a sealed dome for service conditions requiring a pressure tight seal on the discharge side, eg. liquid service.

## TECHNICAL SPECIFICATION

### Approvals

BS6759 Pt 1, 2, & 3  
PED certified Category IV

### Materials

Body - Bronze (-29 to 220°C)  
- Stainless Steel (-29 to 260°C)  
Trim - St. St. / EPDM (-29 to 150°C)  
- St. St. / Aflas (-29 to 200°C)  
- St. St. (-29 to 260°C)

### Size Range

Size	Orifice mm <sup>2</sup>	Min (Barg) Pressure	Max Pressure (Barg)		
			Cl & SS All media	Bronze Gas & liquid	Bronze Steam & hot water
DN15 (1/2")	109	0.35	12.5	32	22
DN20 (3/4")	314	0.35	12.5	24.5	22
DN25 (1")	415	0.35	12.5	20.5	20
DN32 (1 1/4")	660	0.35	12.5	18	18
DN40 (1 1/2")	1075	0.35	12.5	18	18
DN50 (2")	1662	0.35	12.5	18	18

### Performance

	Kdr	Over pressure	Blow down
Steam	0.7	5%	15%*
Hot water ‡	0.7	5%	15%*
Air / Gas	0.7	10%	10%*
Liquid	0.46	10%	20%†

\* or 0.3 Barg min † or 0.6 Barg min ‡ above 100°C

### Maximum Back Pressure

Barg	5.5
Constant	80%
Built-up	10%
Variable	0%

(Total % must not exceed Barg shown)

### Connections

Screwed In x Screwed Out  
Flanged In x Screwed Out

### Construction

Top Guided / Full Lift

### Cap Options

Open lever  
Pressure tight dome

### Sizing

Refer to Capacity Charts (page 60-67)

### Spring Selection

Refer to Spring Selection Chart (page 80)

## PARTS

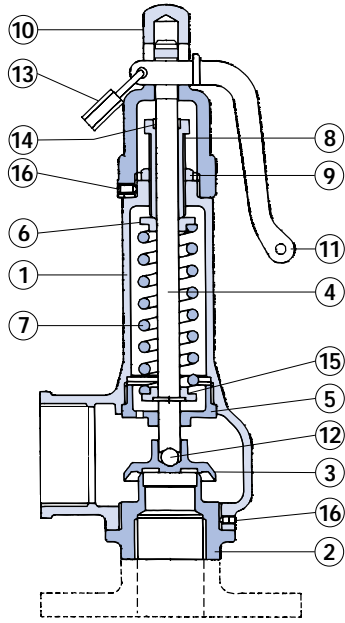

ITEM	PART	MATERIAL	
		St.St.	Bronze
1	Body	St.St	Bronze
2	Seat	St.St	Bronze
3*	Disc	Various	Various
4	Spindle	St.St	Brass
5	Guide	Nickel alloy	Bronze
6	Top Spring Cap	St.St	Brass
7*	Spring	St.St	Chrome vanadium
8	Adjusting Screw	St.St	Brass
9	Lock Nut	St.St	Brass
10†	Dome	St.St	Nylon
11	Lever	N/A	Brass
12*	Ball	Monel	St.St
13	Padlock	N/A	Brass
14	Bush	PTFE	PTFE
15	Bottom Spring Cap	St.St	Brass
16	Pinning Screw	St.St	Brass

Note:

\* Recommended spares; available from Safety Systems UK Ltd.

† Synthetic dome should not be adjacent to external heat sources. Recommended inspection every 12 months.

## DIMENSIONS

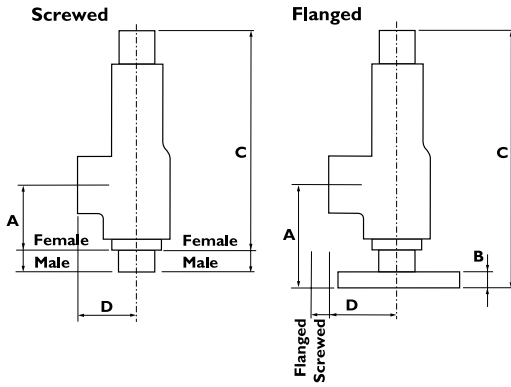

	Valve Type	Valve Size	Inlet	Outlet	A	B	'C' Dome	'C' Lever	D	Weight (kg)
Male x Female	DN15	1/2"	3/4"	58	-	173	192.5	40	1.0	
	DN20	3/4"	1 1/4"	63	-	229	252	55	1.6	
	DN25	1"	1 1/2"	70	-	257	280	60	2.1	
	DN32	1 1/4"	2"	80	-	318.5	351	70	4.0	
	DN40	1 1/2"	2 1/2"	91	-	366.5	405.5	81	7.0	
	DN50	2"	3"	110	-	414.5	456.5	96	10.0	
Female x Female	DN15	1/2"	3/4"	40	-	158	178	40	1.0	
	DN20	3/4"	1 1/4"	44	-	209	232	55	1.6	
	DN25	1"	1 1/2"	48	-	235	258	60	2.1	
	DN32	1 1/4"	2"	58	-	295	328	70	4.0	
	DN40	1 1/2"	2 1/2"	67	-	340	380	81	7.0	
	DN50	2"	3"	80	-	382	424	96	10.0	
Flange x Female	DN20	3/4"	1 1/4"	75	10	242	265	55	2.5	
	DN25	1"	1 1/2"	75	11	261	284	60	3.2	
	DN32	1 1/4"	2"	95	12.7	332	365	70	5.7	
	DN40	1 1/2"	2 1/2"	105	12.7	379	418	81	9.0	
	DN50	2"	3"	120	12.7	422	464	96	12.5	

All dimensions in mm

## FIGURE NUMBERING

716

CODE	TRIM	BODY	CONNECTIONS	CAP
AS BS	St. Steel Aflas	St. Steel	Screwed in and out (Inlet available Male or Female)	D Pressure tight dome
ES VS SS	EPDM Aflas St. Steel	Bronze		L Open lever
AF BF	St. Steel Aflas	St. Steel	Flanged in screwed out	
EF VF SF	EPDM Aflas St. Steel	Bronze		

# 716H Safety Relief Valve

## TECHNICAL SPECIFICATION



### Approvals

ASME VIII  
PED certified Category IV

### Materials

Body - Carbon Steel gr WCB (-29 to 260°C)  
- Stainless Steel gr CF8M (-46 to 260°C)  
Trim - Aflas (-29 to 200°C (No. 7 only))  
- St.St. (-46 to 260°C)  
- EPDM (-29 to 150°C)

### Size Range

Size	Orifice mm <sup>2</sup>	Min (Barg) Pressure	Max (Barg) Pressure
DN15 (1/2")	109 (No.7)	0.35	51
DN20 (3/4")	109 (No.7)	0.35	51
DN25 (1")	109 (No.7)	0.35	51
DN15 (1/2")	45 (No.6)	51	102
DN20 (3/4")	45 (No.6)	51	102

### Performance

	6-Kdr	7-Kdr	Over pressure	Blow down
Steam	0.811	0.824	10%*	15%
Air / Gas	0.811	0.824	10%*	15%
Liquid	0.670	0.505	10%*	15%

\*or 0.2 Barg min

### Maximum Back Pressure

Barg	19.65
Constant	80%
Built-up	10%
Variable	0%

(Total % must not exceed Barg shown)

### Connections

Screwed In x Screwed Out  
Flanged In x Flanged Out (except DN15)

### Construction

Top Guided / Full Lift

### Cap Options

Open lever  
Pressure tight dome  
Packed lever

### Sizing

Refer to Capacity Charts (page 60-67)

## DESIGN

The figure 716H safety relief valve is a high pressure version of the popular 716 valve.

Pressures up to 102 Barg (orifice dependent) can now be accommodated in two high grade materials, Carbon Steel A216-WCB and Stainless Steel A351-CF8M.

The 716H is certified to the ASME VIII code for the full range of flowing media.

## FIGURE NUMBERING

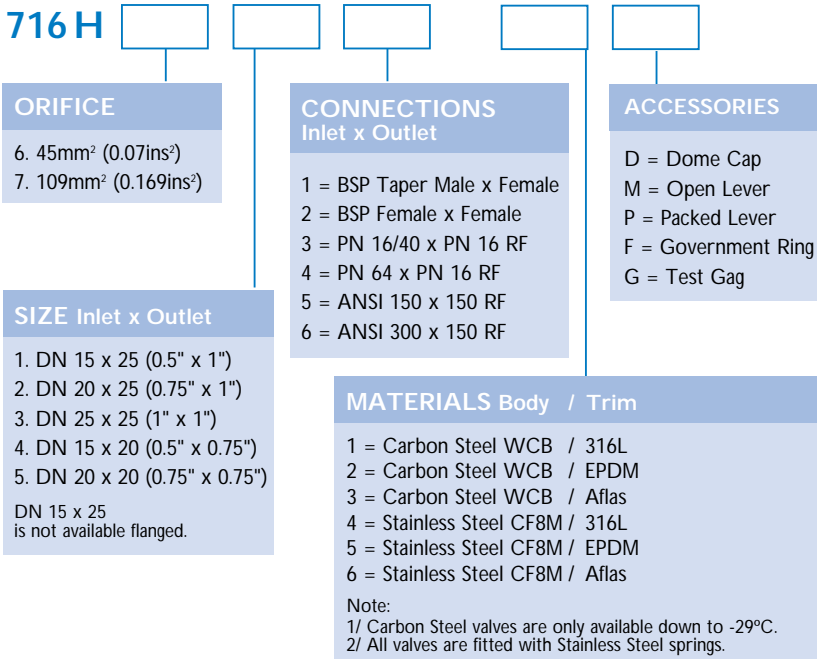

## PARTS

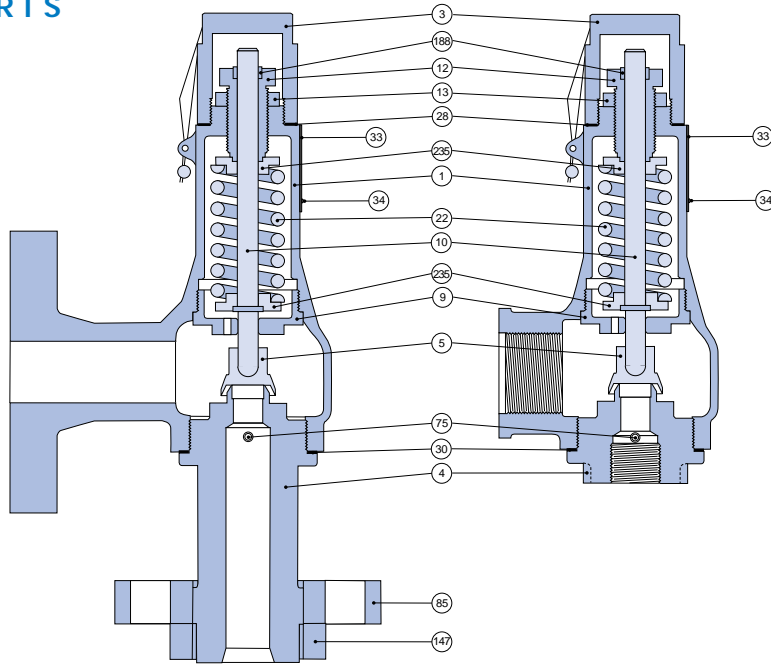

ITEM	PART	CARBON STEEL	STAINLESS STEEL
1	Body	SA 216-WCB CARB ST	SA 351-CF8M ST ST
3	Cap	SA 216-WCB CARB ST	SA 351-CF8M ST ST
4*	Nozzle	ASTM A479-316L	ASTM A479-316L
5*	Disc assy.	VARIOUS	VARIOUS
9	Guide	17/4	17/4
10	Spindle	316	316
12	Adjusting screw	ASTM A479-410	ASTM A479-410
13	Locking nut	ASTM A479-316L	ASTM A479-316L
22*	Spring	C.S. ALUMINIUM COATED	ASTM A313-316
28*	Cap gasket	ST-706 6	ST-706
30	Body gasket	ST-706	ST-706
33	Data plate	321 ST ST	321 ST ST
34	Hammer drive screw	ELECTRO BRASSED CS.	ASTM A479-316L
75	Grub screw	ASTM A479-316L	ASTM A479-316L
85	Inlet flange	SA 105 CARB ST	SA 182-F316 ST ST
147	Flange nut	SA564 17/4 (33HRC)	SA564 17/4 (33HRC)
188	Adjusting screw bush	VIRGIN PTFE	VIRGIN PTFE
235	Spring end plate	ASTM A479-431	ASTM A479-431

\* Recommended spares; available from Safety Systems UK Ltd.  
Recommended inspection every 12 months.

## DIMENSIONS

Female screwed

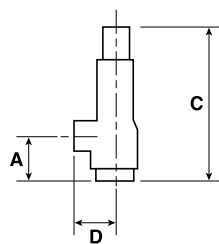

Male screwed

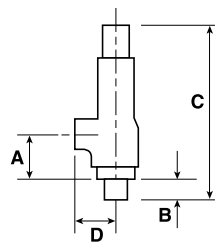

Flanged

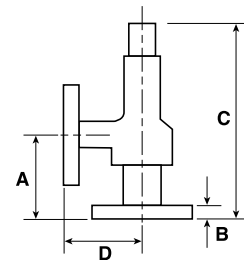

Sizes (ins) inlet & outlet	Inlet & Outlet connection	Orifice No.	A	B	C†	D	Max pressure up to 100°F (Psig)		Weight (kg)
							Inlet	Outlet	
1/2", 3/4" x 3/4"	Screwed Male x Female	6	64	21	257	55	1480	285	4
1/2", 3/4", 1" x 1"	Screwed Female x Female	7	44	-	189	55	740	285	4
1/2", 3/4", 1" x 1"	Screwed Male x Female	7	43	19	209	55	740	285	4
3/4" x 1"	ANSI 150# x 150#	7	117	31	262	95	740	285	6.5
3/4" x 1"	ANSI 300# x 150#			41					
1" x 1"	ANSI 150# x 150#	7	117	33	262	95	740	285	6.5
1" x 1"	ANSI 300# x 150#			45					

†When a Lever or Test Gag is fitted dimension C will increase. All dimensions in mm.

# 716T Pressure and Temperature Safety Relief Valve

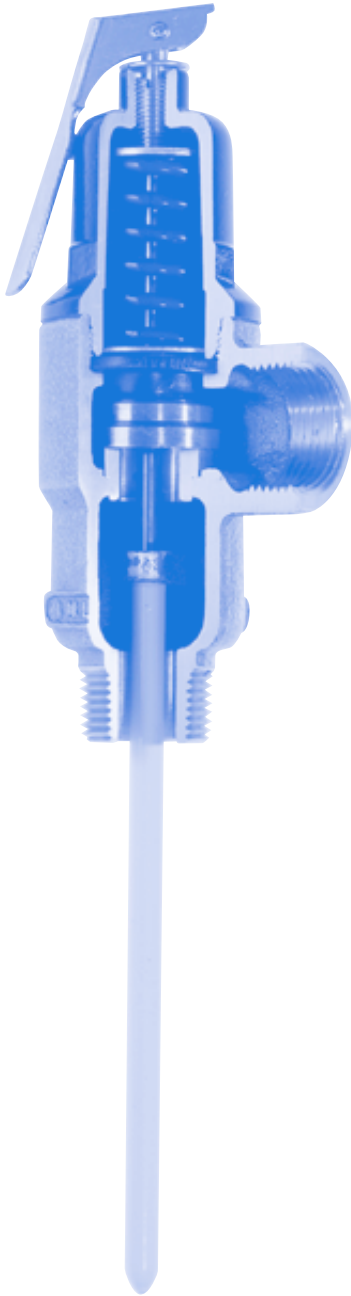

## TECHNICAL SPECIFICATION

### Approvals

ASME Section IV  
 PED certified to Article 3 Paragraph 3  
 (sound engineering practice), hence they do not carry the CE mark  
 Water Regulation Advisory Scheme (WRAS)  
 Also independently tested by the Building Research Establishment

### Materials

Body - Bronze  
 Internals - DZR brass  
 Trim - Silicone

### Size Range

Size	Min (Barg) Pressure	Max (Barg) Pressure
DN20 (3/4")	2.4	10.3
DN25 (1")	2.4	10.3
DN32 (1 1/4")	2.4	10.3
DN40 (1 1/2")	2.4	10.3
DN50 (2")	2.4	10.3

### Connections

Screwed In x Screwed Out

### Construction

Top Guided

### Cap Options

Lever fitted as standard

### Sizing

Refer to Capacity Charts opposite

- WRAS Approved
- Manual Test Lever
- Soft Seated Design
- Double Safety Protection
- Designed to EN1490/BS6283
- Large Discharge Capacities
- Independently Tested by BRE
- Smooth Temperature Probe
- Diaphragm Protection

## DESIGN

The 716T is the ultimate solution to hot water system protection, it protects unvented hot water systems, against both excess pressure and excess temperature. Increasing pressure is sensed by the spring, which automatically opens the relief valve at the pre-set pressure and the integral probe independently monitors increases in temperature, safely opening the relief valve between 90°C and 95°C.

The 716T has capacities well in excess of EN1490:2000 code requirements, and has been independently tested by the Building Research Establishment, in accordance with EN1490:2000 which is to supersede BS6283 pt3.

The temperature probes are designed to have a smooth surface free from crevices, to reduce mineral build-up, and are white powder coated to minimise galvanic action within the heater.

The 716T has a bronze body, DZR brass internals and silicone seat in accordance with potable water code requirements. A soft seat provides leak tight operation. The spring and spring chamber are protected from the hot water by the EPDM diaphragm, reducing corrosion and increasing life in service.

The manual test lever can be easily operated from any position around the valve.



## SIZING

### Temperature Rating in kW

Size	¾"	1"	1¼"	1½"	2"
<b>kW</b>	44	70	80	173	184
<b>kW (Per BSEN 1490)</b>	25	50	75	100	-

To convert kW to Btu/hr multiply by 3400. The temperature probe will safely open the relief valve approximately in the region of 90 to 95°C.

### Pressure Rating in kW

Set P Barg	¾"	1"	1¼"	1½"	2"
2.4	166	186	315	524	631
2.5	171	192	324	540	650
3.0	196	220	371	619	745
4.0	246	277	466	777	935
5.0	296	323	560	935	1125
6.0	345	389	655	1093	1315
7.0	395	445	749	1251	1505
8.0	445	502	844	1409	1695
9.0	495	558	939	1567	1885
10.0	545	614	1033	1725	2075
10.3	560	631	1062	1773	2132

The kW rating shown has been calculated in accordance with BS6759 pt1 and ASME IV. They represent the steam relief capacity of the relief valve at 10% over pressure. To convert kW to Btu/hr multiply by 3400.

## DIMENSIONS

Inlet & Outlet	A	B	C	D	(kg)
<b>BSP</b>					
¾" male x ¾" female	38	62	262	113	0.60
1" male x 1" female	40	53	262	121	0.75
1¼" male x 1" female*	44	50	259	99	1.20
1½" male x 1½" female	63	68	271	80	2.00
2" male x 2" female	63	75	280	65	2.00

\*1¼" valve has a 1" outlet

All dimensions in mm

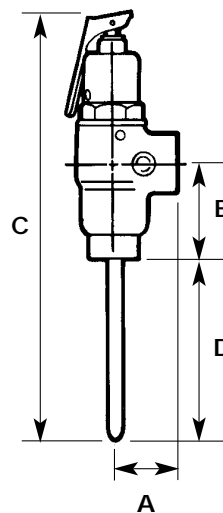

# 746 Safety Relief Valve

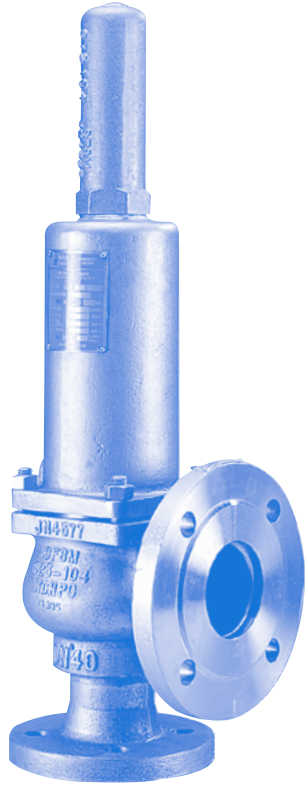

## TECHNICAL SPECIFICATION

### Approvals

- BS6759 Pt 1, 2, & 3
- ASME VIII
- TUV-AD Merkblatt A2
- PED certified Category IV

### Materials

- Body - Carbon St. gr WCB (-29 to 427°C)
- Stainless St. gr CF8M (-46 to 427°C)
- Trim - Stainless Steel (-46 to 427°C)
- Viton (-29 to 200°C)
- PTFE (-46 to 220°C)
- EPDM - Hot Water (-29 to 150°C)

### Size Range

Size	Orifice mm <sup>2</sup>	Min (Barg) Pressure*	Max (Barg) Pressure
DN25 (1")	415	0.35	40
DN32 (1¼")	660	0.35	40
DN40 (1½")	1075	0.35	40
DN50 (2")	1662	0.35	40
DN65 (2½")	2827	0.35	35
DN80 (3")	4301	0.35	32
DN100 (4")	6648	0.35	25

\* Minimum pressure for bellows valves is greater than stated

### Performance (BS6759)

	Kdr	Over pressure	Blow down
Steam	0.7	5%	15%*
Hot water†	0.7	5%	15%*
Air / Gas	0.7	10%	10%*
Liquid	0.46	10%	20%†

\*or 0.3 Barg min for 0.6 Barg min †above 100°C

### Performance (ASME)

	Kdr	Over pressure	Blow down
Steam	0.738	10%	Fixed
Air / Gas	0.738	10%	Fixed
Liquids	0.482	10%	Fixed

### Maximum Back Pressure

Barg	16
Constant	80%
Built-up	5%
Variable	40% (when bellows fitted)

(Total % must not exceed Barg shown)

### Connections

Flanged In x Flanged Out

### Construction

Top Guided / Full Lift

### Cap Options

- Pressure tight dome
- Packed lever
- Open lever

### Sizing

Refer to Capacity Charts (page 60-67)

## DESIGN

The 746 Safety Relief Valve incorporates a freely pivoting disc, which ensures correct alignment with the nozzle. The combination of top guiding, unobstructed seat bore and full lift capability ensures the highest possible discharge rate thus maximum plant protection.

Due to the large flows available the inlet pipework must be sized to give a maximum inlet pressure drop of 3%

The 746 safety relief valve is available in both conventional and balanced bellows types, and features a special disc style for liquid application, which enhances valve performance.

The 'conventional' arrangement is suitable for applications where the built up pressure will not exceed 5%. The conventional valve can also be used in systems where the superimposed backpressure is at a constant level (up to 80%).

The 'balanced bellows' arrangement is for applications where several safety relief valves discharge into a common discharge manifold, or in any circumstances where a variable back pressure can occur, up to a maximum of 40%.

## PARTS

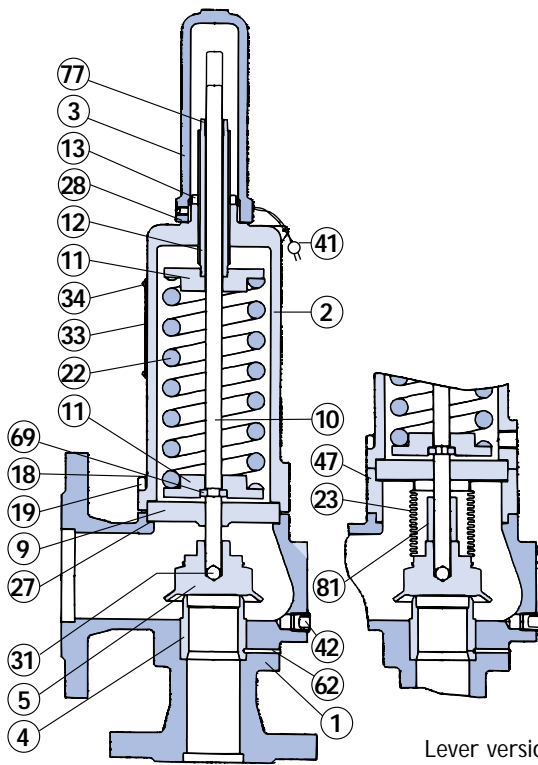

Lever versions are available.

ITEM	PART	MATERIALS	
		Carbon Steel	St.St
1	Body	Carbon St	St.St
2	Bonnet	Carbon St.	St.St
3	Cap	Carbon St.	St.St
4	Seat	St.St	St.St
5*	Disc#	St.St	St.St
9	Guide Plate	St.St	St.St
10 (H)	Spindle	St.St	St.St
11	Spring Plate	St.St	St.St
12	Adjusting Screw	St.St	St.St
13	Locknut	St.St	St.St
18 (H)	Body Stud	Carbon St	St.St
19	Body Nut	Carbon St	St.St
22 (H)	Spring**	C.V	St.St
23 (B)*	Bellows Unit	St.St	St.St
27*	Body/Bonnet Gasket	Garlock	Garlock
28*	Cap Gasket	Garlock	Garlock
31*	Ball	St.St	St.St
33	Nameplate	St.St	St.St
34	Nameplate Pin	Carbon St	St.St
41	Warranty Seal	Lead/wire	Lead/wire
42	Drain Plug	Carbon St	St.St
47(BH)	Spacing Piece	St.St	St.St
62	Seat Pin	St.St	St.St
69	Split Collar	St.St	St.St
77	Adjusting Screw Bush	PTFE	PTFE
81(B)	Lift Stop	St.St	St.St

Note:

B - Denotes used on Bellows type valves.

H - High Pressure type valves; spacer, larger studs, spring and spindle.

# Resilient trims are available.

\* Recommended spares; available from Safety Systems UK Ltd.

\*\* Other spring material options are available dependent on duty.

Recommended inspection every 12 months.

## DIMENSIONS

Flanged x Flanged

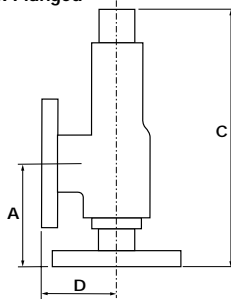

Valve Type	Valve Size	Inlet	Outlet	'C'			Weight (kg)		
				A	Dome	Lever			
Flanged	DN25	1"	1 1/2"	105	410	410	445	100	8.5
	DN32	1 1/4"	2"	115	455	455	490	110	14.0
	DN40	1 1/2"	2 1/2"	140	570	570	605	115	20.0
	DN50	2"	3"	150	615	615	665	120	30.0
	DN65	2 1/2"	4"	170	725	725	785	140	42.5
	DN80	3"	5"	195	825/ 925H	825/ 925H	865/ 965H	160	64.5
	DN100	4"	6"	220	925/ 1030H	925/ 1030H	955/ 1060H	180	86.0

Flange sizes listed are for:  
Carbon Steel Flanges PN 40x16  
Others available on request.

All dimensions in mm

## FIGURE NUMBERING

746/

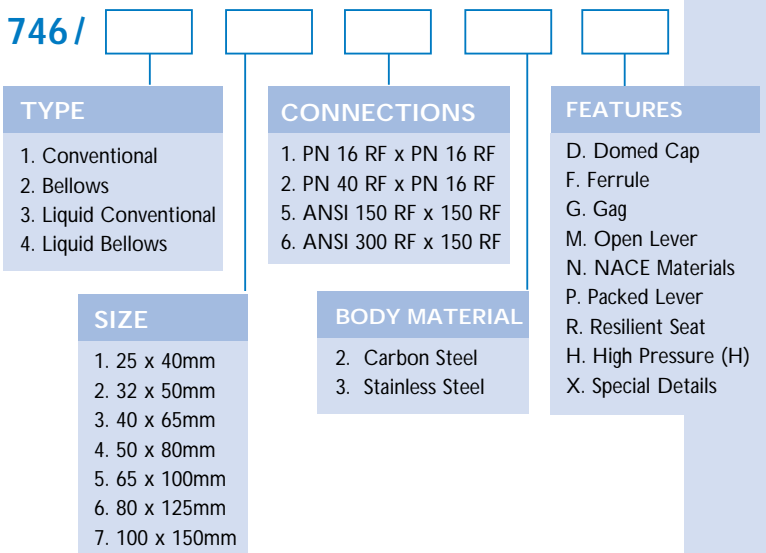

Notes:

A. Any special requirements will be indicated by the letter X which will be agreed with the sales office. For example, paint specification or spring material.

B. Any combination of features can be called up eg. DG, PR, DFRN etc.

C. (H) for '746' 80 and 100mm valves only.

# 756 Safety Relief Valve

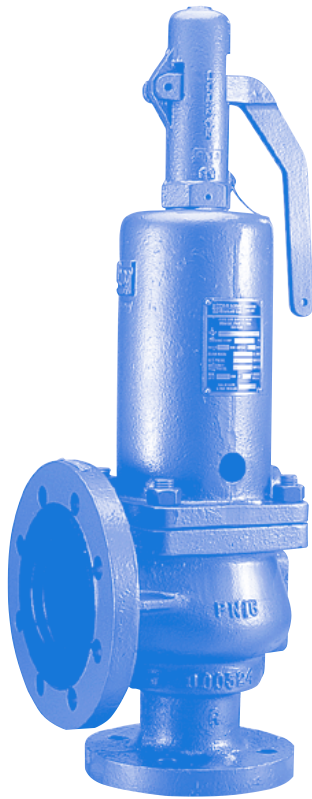

## DESIGN

The 756 Safety Valve combines a top piston guided valve and an unobstructed seat bore with a full lift capability, giving maximum discharge capacity. The design incorporates an adjustable blowdown ring and meets all the requirements of BS6759 Part 1.

A freely pivoting disc and precision lapped stainless steel trim gives positive re-seating for steam duty. As standard the 756 is fitted with a test lever for inline testing. Ideally suited to applications on steam boilers and pipelines where blowdown tolerances are critical.

## TECHNICAL SPECIFICATION

### Approvals

BS6759 Pt 1  
PED certified Category IV

### Materials

Body - Carbon St. gr WCB (-29 to 300°C)  
Trim - Stainless Steel

### Size Range

Size	Orifice mm <sup>2</sup>	Min (Barg) Pressure	Max (Barg) Pressure
DN25 (1")	415	0.35	24
DN32 (1¼")	660	0.35	24
DN40 (1½")	1075	0.35	24
DN50 (2")	1662	0.35	24
DN65 (2½")	2827	0.35	24
DN80 (3")	4301	0.35	24

### Performance

	Kdr	Over pressure	Blow down
Steam	0.716	5%	5%*

\*or 0.3 Barg min

### Maximum Back Pressure

Barg	12
Constant	0%
Built-up	50%
Variable	0%

(Total % must not exceed Barg shown)

### Connections

Flanged In x Flanged Out

### Construction

Top Guided / Full Lift

### Cap Options

Open lever fitted as standard

### Sizing

Refer to Capacity Charts (page 60-67)

## PARTS

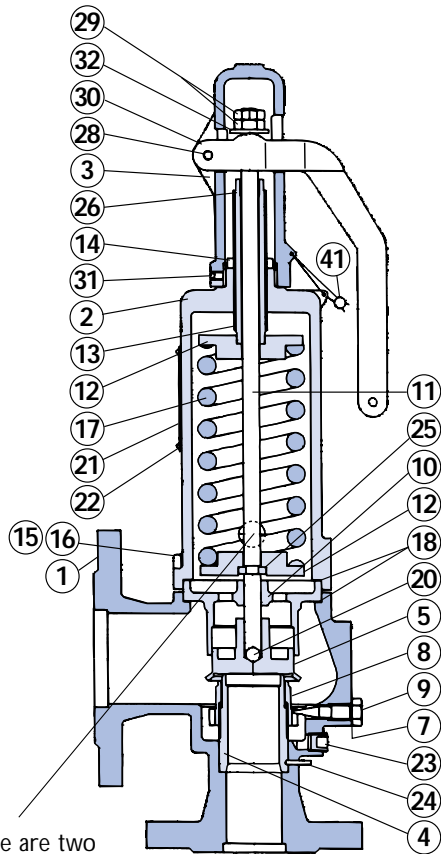

There are two vent holes to ensure spring chamber is at atmospheric pressure.

ITEM	PART	MATERIAL
		Carbon Steel
1	Body	Carbon Steel
2	Bonnet	Carbon Steel
3	Cap	Carbon Steel
4	Seat	St.St.
5*	Disc	St.St.
7*	Set Screw Gasket	NAF
8	Blowdown Ring	St.St.
9	Setting Screw	Brass
10	Guide Plate	Bronze
11	Spindle	St.St.
12	Spring Plate	Brass
13	Adjusting Screw	Brass
14	Locknut	Brass
15	Body Stud	Carbon Steel
16	Body Nut	Carbon Steel
17*	Spring	Chrome Vanadium
18*	Body/Bonnet Gasket	NAF
20*	Ball	St.St.
21	Nameplate	St.St.
22	Nameplate Pin	Steel
23	Drain Plug	Steel
24	Seat Pin	St.St.
25*	Split Collar	St.St.
26	Adjusting Screw Bush	PTFE
28	Fulcrum Pin	St.St.
29	Spindle nut	Brass
30	Easing Lever	Carbon Steel
31	Grub Screw	St.St.
32	Spindle Washer	St.St.
41	Warranty Seal	Lead

\* Recommended spares; available from Safety Systems UK Ltd. Recommended inspection every 12 months.

## DIMENSIONS

Flanged x Flanged

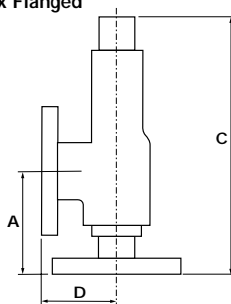

Valve Type	Valve Size	Inlet *NB	Outlet *NB	A	'C' Lever	D	Weight (kg)
Flanged	DN25	1"	1½"	105	410	100	8.5
	DN32	1¼"	2"	115	455	110	14.0
	DN40	1½"	2½"	140	570	115	20.0
	DN50	2"	3"	150	615	120	30.0
	DN65	2½"	4"	170	725	140	42.5
	DN80	3"	5"	195	825*	160	64.5

\*Add 100mm to the DN80 Fig. 756 valve All dimensions in mm only for set pressures above 14 Barg.

Flange sizes listed are for:  
Carbon Steel Flanges PN 40x16  
Others available on request.

## FIGURE NUMBERING

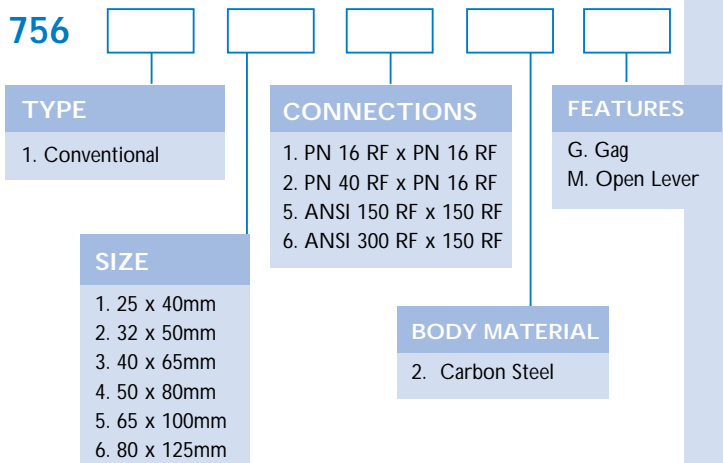

Notes:

A. Any special requirements will be indicated by the letter X which will be agreed with the sales office. For example, paint specification or spring material.

# 766 Safety Relief Valve

## TECHNICAL SPECIFICATION

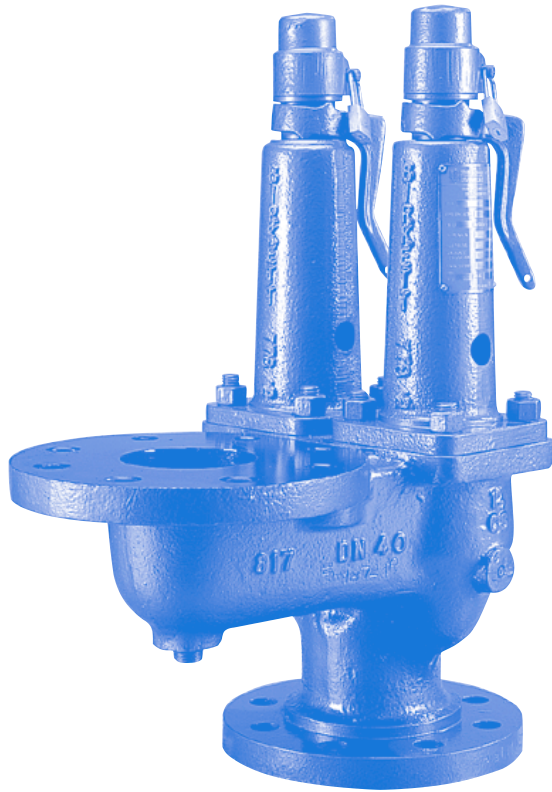

### Approvals

BS6759 Pt 1  
PED certified Category IV

### Materials

Body - Carbon St. gr WCB (-29 to 230°C)  
Trim - Stainless Steel (-29 to 230°C)

### Size Range

Size	Orifice mm <sup>2</sup>	Min (Barg) Pressure	Max (Barg) Pressure
DN40 (1½")	2280	0.35	24
DN50 (2")	4054	0.35	24
DN65 (2½")	6334	0.35	24
DN80 (3")	9121	0.35	24

### Performance

	Kdr	Over pressure	Blow down
Steam	0.4	10%	10%*

\*or 0.3 Barg min

### Maximum Back Pressure

Barg	CS 12 / CI 6
Constant	0%
Built-up	50%
Variable	0%

(Total % must not exceed Barg shown)

### Connections

Flanged In x Flanged Out

### Construction

Top Guided / High Lift

### Cap Options

Open lever fitted as standard

### Sizing

Refer to Capacity Charts (page 60-67)

## DESIGN

The 766 Safety Valve is a double spring high lift valve with high discharge capacity. The top guided piston design incorporates an adjustable blowdown ring and meets all the requirements of BS6759 Part 1.

A freely pivoting disc and precision lapped stainless steel trim gives positive re-seating for steam duty. Fitted as standard with test lever for inline testing. Ideally suited to applications on steam boilers and pipelines where blowdown tolerances are critical.

## FIGURE NUMBERING

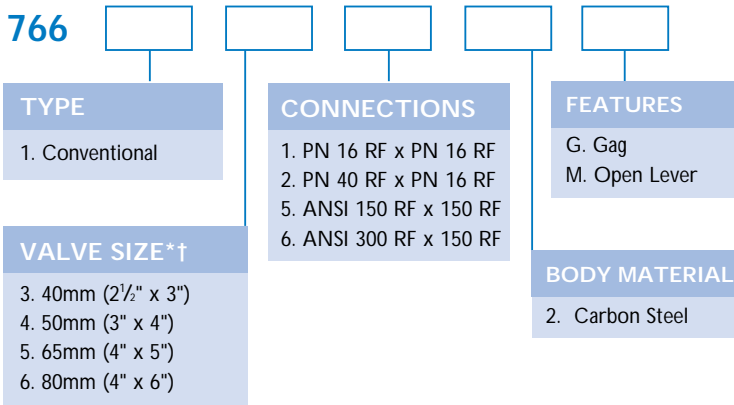

\*Flange sizes are larger than the valve size, refer to the dimension table

Notes:

- A. Any special requirements will be indicated by the letter X which will be agreed with the sales office. For example, paint specification or spring material.
- B. Any combination of features can be called up eg. MG etc.
- C. Flange options are dependant on Valve Body materials, as detailed opposite.

† Please see table on page 22 for inlet and outlet connection sizes.

## PARTS

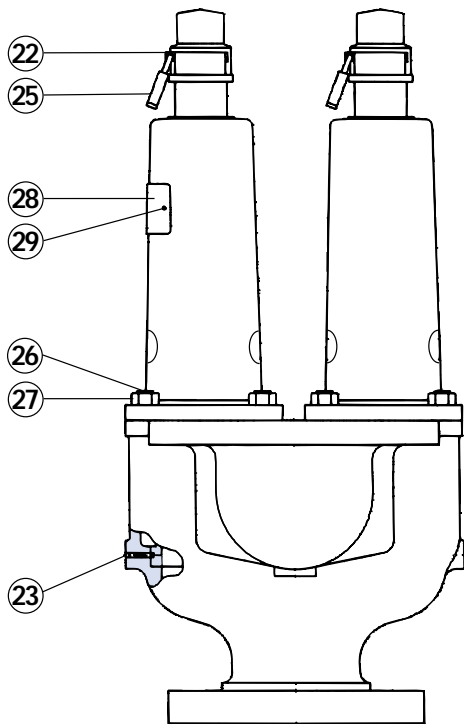
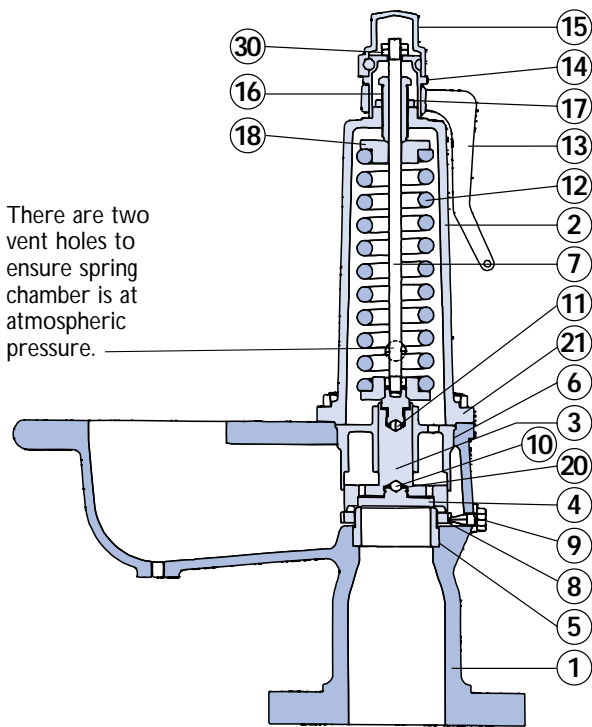

ITEM	PART	MATERIAL
1	Body	Carbon Steel
2	Cover	Carbon Steel
3	Valve Disc Holder	Bronze
4*	Valve Disc	St.St.
5	Seat Ring	St.St.
6	Guide	Bronze
7	Spindle	St.St.
8	Blow Down Ring	St.St.
9	Setting Screw	St.St.
10*	Valve Disc Ball	St.St.
11*	Spindle Ball	St.St.
12*	Spring	Chrome Vanadium
13	Easing Lever	SG Iron
14	Dome	Bronze
15	Dome Cap	Carbon Steel
16	Adjusting Screw	Brass
17	Locknut	Brass
18	Spring plate	Plated Steel
20*	Disc Retaining Clip	St.St.
21*	Body Gasket	Garlock
22	Locking Pin	Brass
23	Seat Securing Pin	St.St.
25	Padlock	Brass
26	Body Stud	Steel
27	Body Stud Nut	Steel
28	Nameplate	St.St.
29	Nameplate screw	Steel
30	Locknut	Steel

Note:

\* Recommended spares; available from Safety Systems UK Ltd.  
Recommended inspection every 12 months.

## DIMENSIONS

Flanged x Flanged

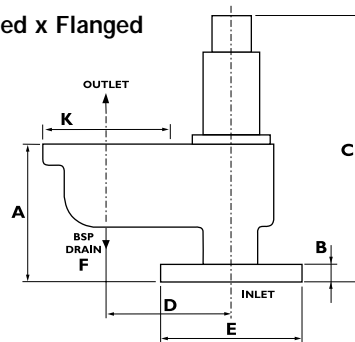

Valve Type	Valve Size	Inlet†	Outlet†	A	B CS	C CS	D	E CS	F (BSP DRAIN)	K CS	Weight (kg)
Flanged	DN40	2½"	3"	197	22	452	156	185	⅜"	200	25
	DN50	3"	4"	229	24	498	181	200	½"	220	38
	DN65	4"	5"	279	24	660	219	235	½"	250	58
	DN80	4"	6"	295	24	702	238	235	½"	285	83

Flange sizes listed are for:  
Carbon Steel Flanges PN 40x16  
Others available on request.

All dimensions in mm.

# 776 Cryogenic Safety Valve



## DESIGN

The 776 Safety Relief Valve is designed for cryogenic duty down to  $-196^{\circ}\text{C}$ . The valve combines a full lift design and top guided construction with an unobstructed seat bore to provide maximum discharge capacity. Positive sealing is achieved through a freely pivoted disc with Kel F (PCTFE) soft seat technology.

The valve is designed to conform with ISO4126, AD Merkblatt A2, ASME VIII and BS6759 Parts 2 & 3.

Production assembly and tests are carried out in accordance with both BOC and Air Products specifications.

BOC specification: 1819660 and 399856.

Air Products specification: 4WPI-EW80010, and 4WPI-SW70003.

## TECHNICAL SPECIFICATION

### Approvals

AD Merkblatt A2  
ASME VIII  
BS 6759 Pt. 2 & 3  
PED certified Category IV

### Materials

Body - Bronze ( $-196$  to  $60^{\circ}\text{C}$ )  
- Stainless steel ( $-268$  to  $60^{\circ}\text{C}$ )  
Trim - Kel F PCTFE ( $-268$  to  $60^{\circ}\text{C}$ )

### Size Range

Size (Orifice code)	Orifice mm <sup>2</sup>	Min (Barg) Pressure	Max (Barg) Pressure
DN15 (1 & 2M)	109	1	41.3
DN20 (2R)	109	1	41.3
DN20 (2 & 2M1)	109	1	41.3
DN20 (3)	314	1	38.6
DN25 (4)	314	1	38.6
DN32 (5)	415	1	34.5
DN40 (6)	660	1	34.5
DN50 (7)	1075	1	31

### Coefficient of Discharge

Air (TUV alpha W)	Above 3 Barg	Above 2.5 Barg	Above 2 Barg	Above 1.5 Barg	Above 1 Barg
Orifice codes 1, 2, 4, 5, 6, 7	0.69	0.69	0.69	0.67	0.63
3	0.67	0.65	0.63	0.62	0.58
1R, 2R	0.40	0.40	0.40	0.39	0.36
Air (ASME Kdr)	0.737				

### Performance

Over Pressure 10%      Blowdown 10%

### Maximum Back Pressure

Barg	5.5
Constant	80%
Built-up	10%
Variable	0%

(Total % must not exceed Barg shown)

### Connections

Screwed In x Screwed Out

### Construction

Top Guided / Full Lift

### Cap Options

Pressure tight dome fitted as standard

### Sizing

Refer to Capacity Charts (page 60-67)



## PARTS

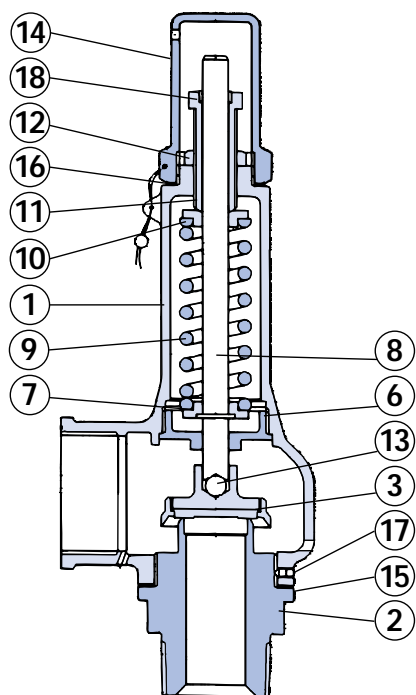

ITEM	PART	MATERIAL
1	Body	Bronze
2	Seat	Bronze
3*	Disc Assembly	St.St. / Kel F PCTFE
6	Guide	Bronze
7	Lower Spring Plate	Brass
8	Spindle	Brass
9*	Spring	St.St
10	Upper Spring Plate	Brass
11	Adjusting Screw	Brass
12	Locknut	Brass
13*	Ball	St.St
14	Cap	Brass
15*	Body Gasket	Gylon PTFE
16*	Cap Gasket	Gylon PTFE
17	Grubscrew	St.St
18	Bush	PTFE

Note:

\* Recommended spares; available from Safety Systems UK Ltd.  
Refer to factory for Stainless Steel version.  
Recommended inspection every 12 months.

## DIMENSIONS

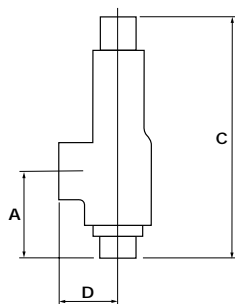

Valve Type	Valve Size	Inlet *BSP	Outlet *BSP	A	'C' Dome	D	Weight (kg)
Male x Female	DN15 /1	1/2"	3/4"	52	173	40	1.0
	DN15 /1R	1/2"	3/4"	52	173	40	1.0
	DN15 /2M	1/2"	1"	52	173	45	1.0
	DN20 /2R	3/4"	1"	70	191	45	1.0
	DN20 /2	3/4"	1"	70	191	45	1.0
	DN20 /3	3/4"	1 1/4"	63	231	55	1.6
	DN25 /2M1	1"	1"	70	191	45	1.0
	DN25 /4	1"	1 1/4"	73	241	55	1.6
	DN32 /5	1 1/4"	1 1/2"	78	265	60	2.1
	DN40 /6	1 1/2"	2"	84	323	70	4.0
	DN50 /7	2"	2 1/2"	95	371	81	7.0

\* Other threaded options are also available.  
All dimensions in mm.

## FIGURE NUMBERING

Fig.	Size	Trim	Connections
776/1	DN15 x 20		
776/1R	DN15 x 20		
776/2M	DN15 x 25		
776/2R	DN20 x 25		
776/2	DN20 x 25	Soft Seat	*Screwed
776/3	DN20 x 32	Kel F	BSP
776/2M1	DN25 x 25		
776/4	DN25 x 32	(PCTFE)	Male x
776/5	DN32 x 40		Female
776/6	DN40 x 50		
776/7	DN50 x 65		

# 480/85/90 Relief Valve



## DESIGN

This spring operated liquid relief valve has a cartridge type assembly which can be withdrawn from the body without disturbing the spring setting and hence relieving pressure. This allows the seating surfaces to be cleaned without the need to reset the valve. The 480 is a bronze relief valve, the 485 is also bronze with a renewable stainless steel seat and disc, while the 490 is all stainless steel.

Typically for use on positive displacement pumps, for relief or bypass duties. The spring cartridge assembly can be supplied separately for use as an integral pump bypass relief valve.

The spindle is normally fitted with an 'O' ring to protect the spring particularly on corrosive duties.

## TECHNICAL SPECIFICATION

### Approvals

BS6759 Pt 3  
PED certified Category IV

### Materials

Body - Bronze (-20 to 120°C) with 'O' ring  
 - Bronze (-20 to 224°C) without 'O' ring  
 - Stainless Steel (-20 to 200°C) with 'O' ring  
 - Stainless Steel (-20 to 260°C) without 'O' ring  
 Trim - Bronze  
 - Stainless Steel

### Size Range

Size	Orifice mm <sup>2</sup>	Min (Barg) Pressure	Max (Barg) Pressure
DN20 (3/4")	285	0.35	24
DN25 (1")	507	0.35	24
DN40 (1 1/2")	1140	0.35	24
DN50 (2")	2027	0.35	24
DN80 (3")	4560	0.35	10

### Performance

	Kdr	Over pressure	Blow down
Liquid for 0.6 Barg min	0.11	10%	20%†

### Maximum Back Pressure

Barg	5.5
Constant	80%
Built-up	10%
Variable	0%

(Total % must not exceed Barg shown)

### Connections

Screwed In x Screwed Out

### Construction

Top Guided

### Cap Options

Pressure tight dome

### Sizing

Refer to Capacity Charts (page 60-67)

### Spring Selection

Refer to Spring Selection Chart (page 79)

## PARTS

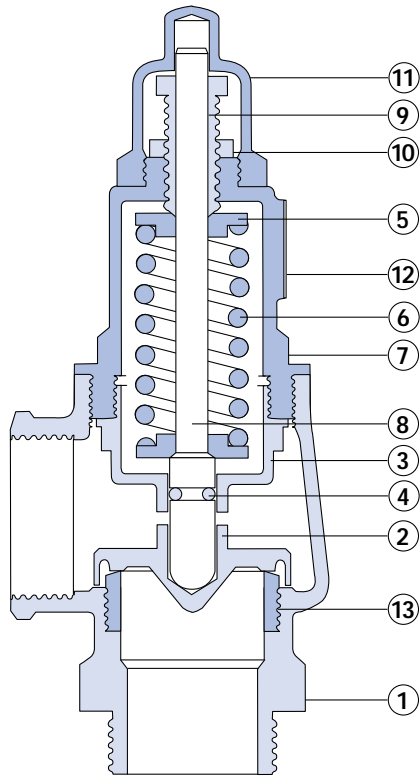

ITEM	PART	MATERIAL	
		480	490
1	Body	Bronze	St. St.
2	Valve Disc	Bronze*	St. St.
3	Guide	Bronze	St. St.
4	'O' Ring	Nitrile	Viton
5	Spring Plate	Brass	St. St.
6	Spring	C. S.	St. St.
7	Cover	Bronze	St. St.
8	Spindle	Bronze	St. St.
9	Adjusting Screw	Brass	St. St.
10	Locknut	Brass	St. St.
11	Dome	Bronze	St. St.
12	Nameplate	Aluminium	Aluminium
13	Renewable Seat	Bronze*	St. St.

\*Materials for Fig 485 are the same as Fig 480 except items 2 & 13 which are Stainless Steel.

## DIMENSIONS

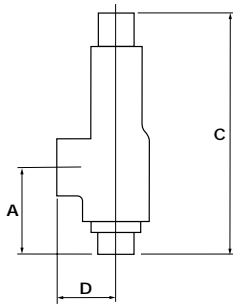

Valve Type	Valve Size	Inlet & Outlet (BSP)	A	'C' Dome	D	Weight (kg)
Male x Female	DN20	3/4"	49	176	41	1
	DN25	1"	64	198	45	2
	DN40	1 1/2"	73	237	56	3
	DN50	2"	91	270	64	5
	DN80	3"	111	390	86	13

All dimensions in mm.

## FIGURE NUMBERING

FIGURE No.	BODY MATERIAL	TRIM MATERIAL	CAP	
480	Bronze	Bronze		Screwed
485	Bronze	Stainless Steel	Dome	
490	Stainless Steel	Stainless Steel		

# 616D Safety Valve



## TECHNICAL SPECIFICATION

### Approvals

BS6759 Pt 2  
PED certified Category IV

### Materials

Body - Aluminium (-30 to 200°C)  
Trim - PTFE/Bronze

### Size Range

Size	Orifice mm <sup>2</sup>	Min (Barg) Pressure	Max (Barg) Pressure
DN40 (1½")	1140	0.2	2.5
DN50 (2")	2027	0.2	2.5

### Kdr (Coefficient of discharge)

Air Variable

### Maximum Back Pressure

Not applicable on open discharge

### Connections

Screwed In x Open discharge

### Construction

Top Guided

### Cap Options

Dome

### Sizing

Refer to Capacity Charts (page 60-67)

## DESIGN

The type 616D is a spring operated high capacity safety valve for low-pressure air applications. It is designed to deliver precise relieving and re-seating pressures while the protected open discharge gives downward flow. The non-stick seating surfaces give positive shut-off and freedom from sticking, whilst the mixture of aluminium and gunmetal make it light but very robust. Typically used on blowers or bulk transfer road/rail transport vehicles.

It is specially designed to give overpressure protection of positive displacement air blowers and associated tanks or pressure vessels.

## INSTALLATION OF 616D

Mount the valve in a vertical position whenever possible. (It may be mounted at any angle up to 45° without detriment.) Ensure that the valve discharge is unobstructed and does not create a hazard to persons or property.

The branch leading to the valve must be the same nominal bore as the valve (or larger) and bushed down at the valve entry. The length must be kept as short as possible.

Due to the adverse effect of pressure pulsations from the usual Rootes-type blowers, the valve should not be mounted within 1.25m of the blower outlet. However, no valve or other obstruction must intervene between the blower and the safety valve.

## PARTS

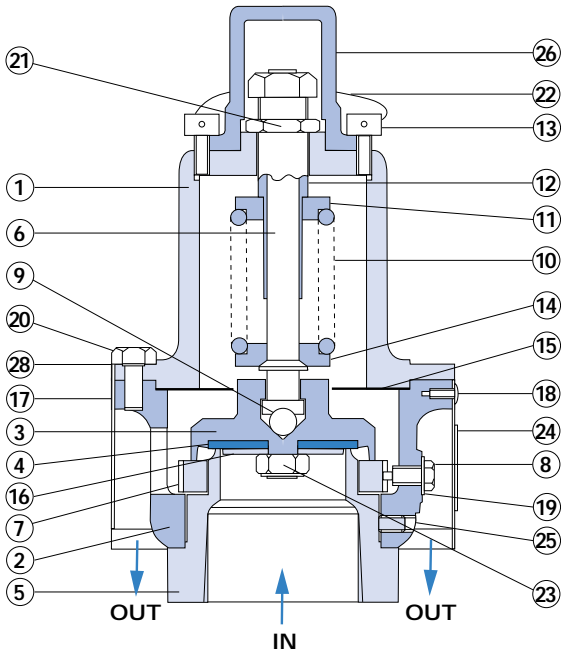

ITEM	PART	MATERIAL
1	Cover	Aluminium
2	Body	Aluminium
3	Disc Holder	Aluminium
4	Disc	PTFE
5	Seat	Bronze
6	Spindle	St. St.
7	Blow Down Ring	Bronze
8	Setting Screw	Ni. pl. Steel
9	Spindle Ball	St. St.
10	Spring	St. St.
11	Upper Spring Cap	Mild Steel
12	Adjusting Screw	Brass
13	Cap Screw	St. St.
14	Bottom Spring Cap	Mild Steel
15	Dust Shield	Aluminium
16	Disc Support	Zi. pl. Steel
17	Cowl	Zi. pl. Steel
18	Self Tapping Screw	Zi. pl. Steel
19	Shakeproof Washer	St. St.
20	Set Screw	St. St.
21	Locknut	Brass
22	Wire and Lead Seal	Lead & St. St.
23	Self Locking Nut	Brass
24	Nameplate	Aluminium
25	Grub Screw	Steel
26	Locking Dome	Nylon
28	Starwasher	St. St.

## DIMENSIONS

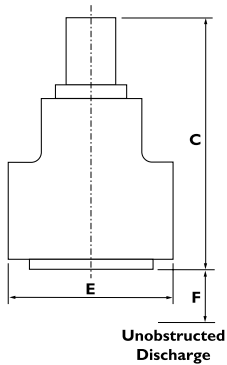

Valve Type	Valve Size	Inlet (BSP)	C	E	F	Weight (kg)
Screwed	DN40	1½"	194	102	10	1.8
	DN50	2"	205	127	13	2.0

All dimensions in mm.

## FIGURE NUMBERING

FIGURE No.	BODY MATERIAL	TRIM MATERIAL	CAP	CONNECTION
616D	Aluminium	PTFE / Bronze	Dome	Screwed Bottom Inlet Open Discharge

# Pressure Reducing Valves

## INTRODUCTION

You may be processing chemicals, producing food or drink, heating factories, sterilizing hospital equipment, supplying potable water in high rise buildings or fighting fires. Whatever the process, the chances are at some stage you will need to depend on a pressure reducing valve.

Bailey produce a wide range of dependable pressure reducing valves which independently and without intervention, monitor the supply pressure and automatically deliver a consistent reduced pressure for the operator, day and night.

When steam, air, water, liquids, gas or chemicals are to be used, boilers, pumps and compressors are quite often required to pressurise the system. The initial system pressure is usually high due to the use of small diameter cost effective piping systems, and it will be substantially higher than the pressure required by the final application. Most of these applications require reliable, constant and stable reduced pressures, without which the process would lose or produce poor quality products.

The comprehensive Bailey range of pressure reducing valves is used throughout the world on a huge array of applications; below is a guide to which valve type is best suited for a given application.

## PRESSURE REDUCING VALVES - APPLICATIONS

Application	Material	Size	Recommended Valve Type
Steam	Bronze	15 to 50mm	2042/3 - Bailey B
	Carbon Steel	65 to 150mm	2044
	Carbon Steel	65 to 150mm	2045
	Carbon Steel	15 to 100mm	2046
Water/Liquid	Bronze	Screwed 15 to 50mm	C10
	Bronze	Screwed/Flanged 15 to 50mm	Class T
	Bronze	Screwed/Flanged 25 to 50mm	Class TH
Air	Bronze	15 to 50mm	2042/3 - C10/Class T
	Carbon Steel	65 to 150mm	2044
	Carbon Steel	15 to 50mm	2046
	Carbon Steel	65 to 150mm*	2045/6
Fine Gas	Bronze	15 to 50mm	2042/3 GN - C10/Class T
	Carbon Steel	65 to 150mm	2044 GP
	Carbon Steel	15 to 50mm	2046 GN
	Carbon Steel	65 to 150mm*	2045/6 GP
Oxygen and Methane	Bronze	15 to 50mm	2042/3 OV
Fire fighting hose pressure regulator	Bronze	Flanged 40 to 80mm	Class F
	AB2	Screwed 50 to 65mm	
	Titanium		

Accurate selection of the valve type depends on:  
inlet/outlet pressure - capacity - material - temperature - fluid - connection required.

\*2046 Valves only available up to 100mm

# G4 Series

## PILOT OPERATED PRESSURE REDUCING VALVES

### ...Extremely sensitive and accurate

The 'G4' pressure reducing valve is designed for use on steam, air and gases. It will maintain a constant outlet pressure irrespective of variations in the inlet pressure or demand from the system.

Initially with no compression on the adjusting screw, both the pilot and main valve seats are closed due to the action of the springs in the pilot and main valve. Fluid at the inlet pressure passes up the inlet relay port to the pilot valve seat which is opened by clockwise (viewed from above) rotation of the adjusting screw. This compresses the adjusting spring and applies load to the topside of the diaphragm, pushing open the pilot valve. Fluid now passes through the pilot valve seat, through the relay port to the top of the large diameter piston, which in turn pushes the main valve open.

The pressure of the fluid is reduced as it passes through the open main valve from the inlet to the valve outlet. At the same time fluid passes up the outlet relay port to the underside of the diaphragm, from where the outlet pressure is controlled.

The outlet pressure is a result of the balancing of the forces acting on the diaphragm, from the adjusting spring above and the reduced pressure from below.

The 'G4' is extremely sensitive and accurate, due to the large diaphragm. Inlet variations, or demand from the system, will attempt to affect the outlet pressure. Such attempts will result in movement of the pilot valve, which in turn minutely moves the piston and main valve. Thus the outlet pressure is maintained and the controlling cycle starts again.

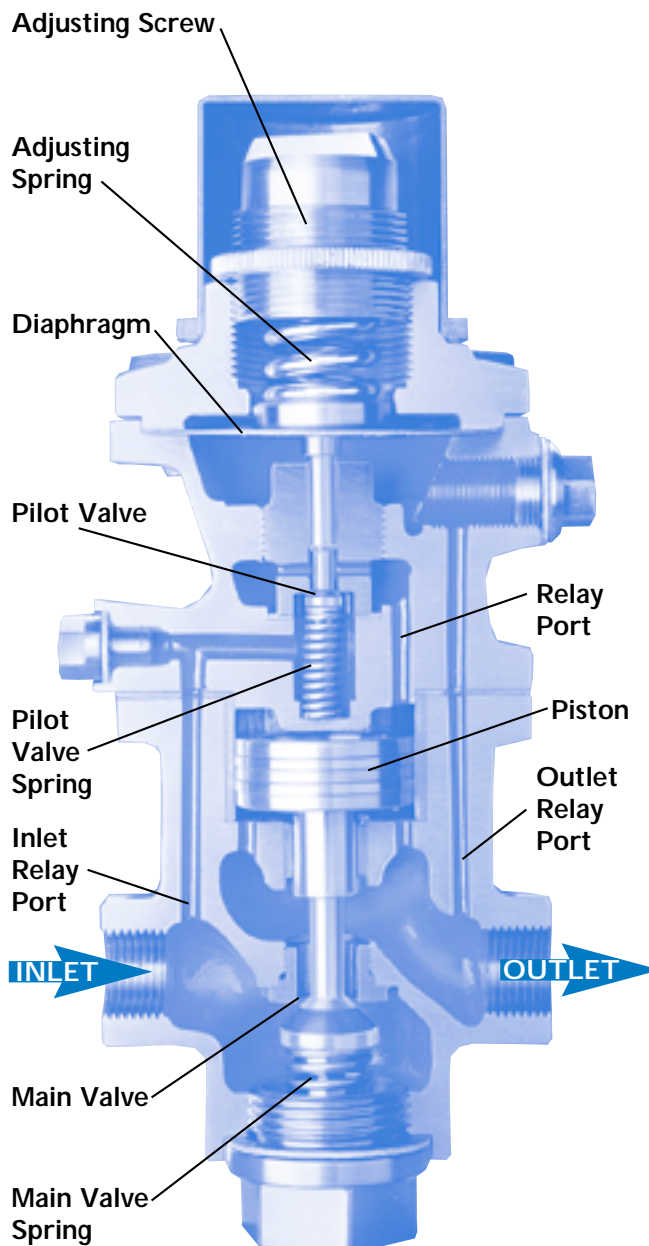

## PRESSURE EQUIPMENT DIRECTIVE (PED)

The G4 pressure reducing valve is fully compliant/certified to the PED as follows:

Sizes DN15 to DN25 in accordance with article 3, paragraph 3 (sound engineering practice) hence do not require the CE mark.

Sizes DN32 to DN100 to Category II, group 1 gases (CE marked)

Sizes DN32 to DN150 to Category II, group 2 gases (CE marked)

## REMOTE PRESSURE SENSING

### For Steam Applications

The 'G4' is a self-actuated, pilot operated pressure reducing valve and it relies upon a stable pressure signal from the outlet pipe work in order to maintain stable control of the outlet pressure.

However, under certain conditions the signal pressure may be unstable in the immediate vicinity of the valve outlet and as a result may cause erratic control.

This can easily be overcome by installing a balance pipe from the remote sensing port to a straight section of the outlet pipe where stable flow has been resumed (see diagram below).

Ideally the balance pipe should be a minimum of 2 metres (6 feet) long and must be screwed into the remote sensing port to the required depth, see page 38. It should also include a pipe union and stop valve to allow dismantling and isolation. It should be installed with a steady fall away from the reducing valve, to facilitate self drainage of condensate.

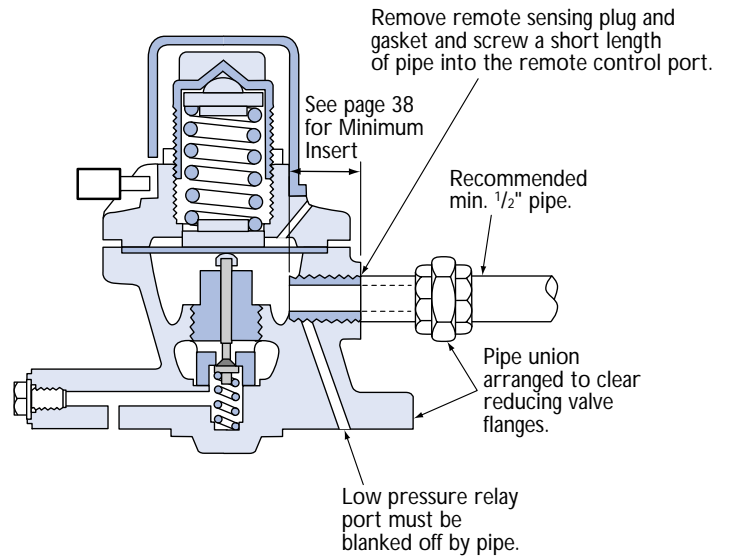

### We recommend fitting a balance pipe:

1. When the reduced pressure is below 55% of the inlet pressure.
2. When a low pressure top is fitted.
3. When difficult outlet pipe work conditions occur.

We do not recommend fitting a balance pipe on air/gas applications. To ensure correct operation the G4 should be mounted at least 10 pipe diameters from restrictions such as other valves or bends.

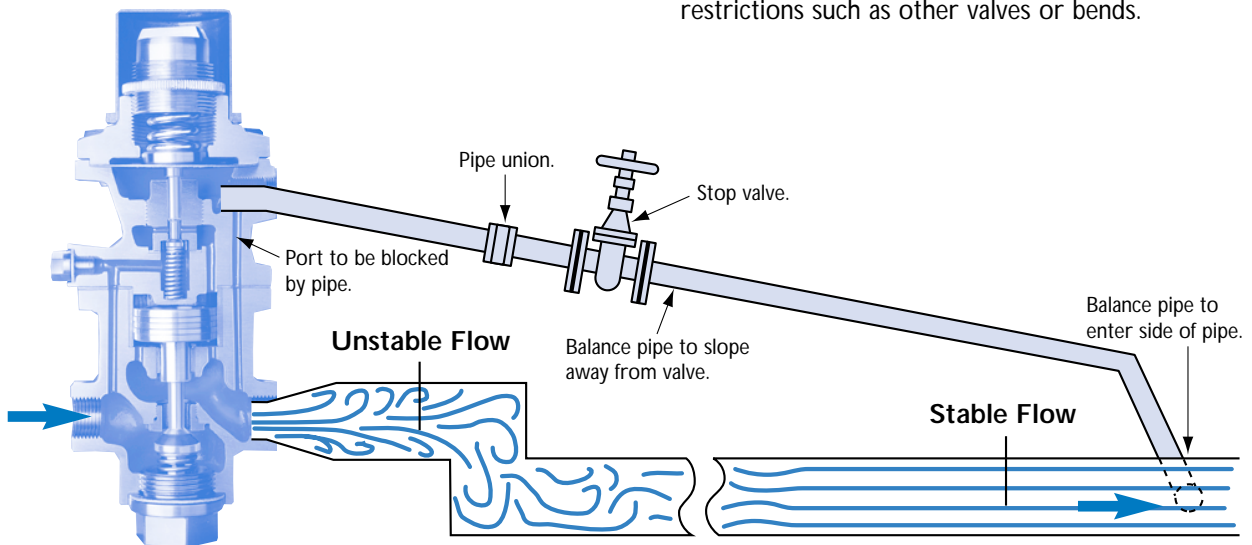



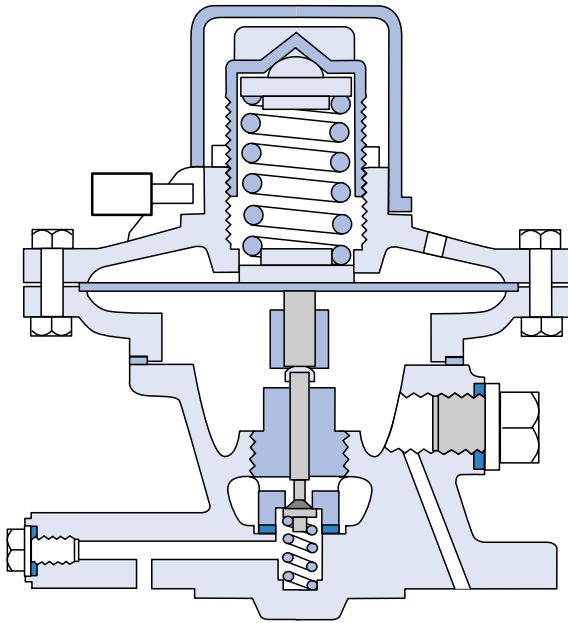

The standard 'G4' pilot top can reduce pressures down to 0.35 Barg (5 Psig). For pressures below this, a bronze low pressure pilot top can be fitted in place of the standard top. It is suitable for outlet pressures from 0.07 to 0.35 Barg (1 to 5 Psig) using the yellow spring. The low pressure top is available for fitting on to valve sizes 15 to 100mm ( $\frac{1}{2}$  to 4 inch), and a balance line should always be fitted to a low pressure top, on steam duty and never on air/gas duty.

*Note: A low pressure top is only suitable for inlet pressure up to a maximum of 7 Barg (100 Psig).*

*Higher inlet pressures can be accommodated by use of two G4 valves 'in-series', refer to page 37.*

The low pressure top can also be supplied as a **conversion kit**, allowing existing valves and stock to be modified quickly should the need suddenly arise.

The 'G4' has successfully been used for many years with metal seats on demanding steam applications. However soft seated versions are available for industrial fine gas applications, involving such gases as carbon dioxide, nitrogen and oxygen. Typical application areas would include pharmaceuticals, food processing and brewing.

The 'G4' utilises a range of soft elastomer seat materials to meet the ever growing demand for these specialist applications.

In addition, valves for active gases, such as oxygen and methane, can be supplied fully assembled and tested to "oxygen service" standard in Bailey's state of the art clean room facility. This facility complies fully with the "Industrial Gas Committee" guidelines.

All soft seat options can also be supplied as **conversion kits**, allowing existing valves and stock to be modified quickly should the need suddenly arise.

We do not recommend fitting a balance pipe on gas applications. To ensure correct operation the G4 should be mounted at least 10 pipe diameters from restrictions such as other valves or bends.

PARTS

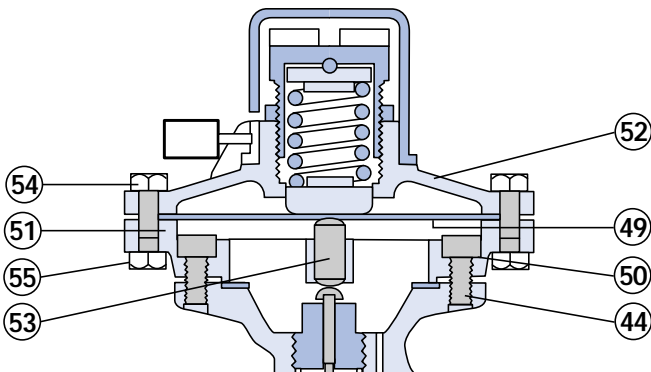
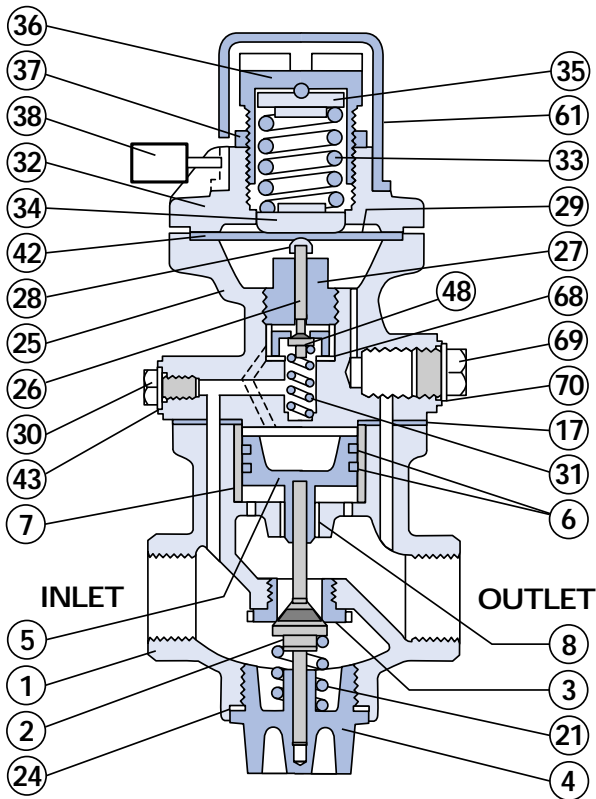
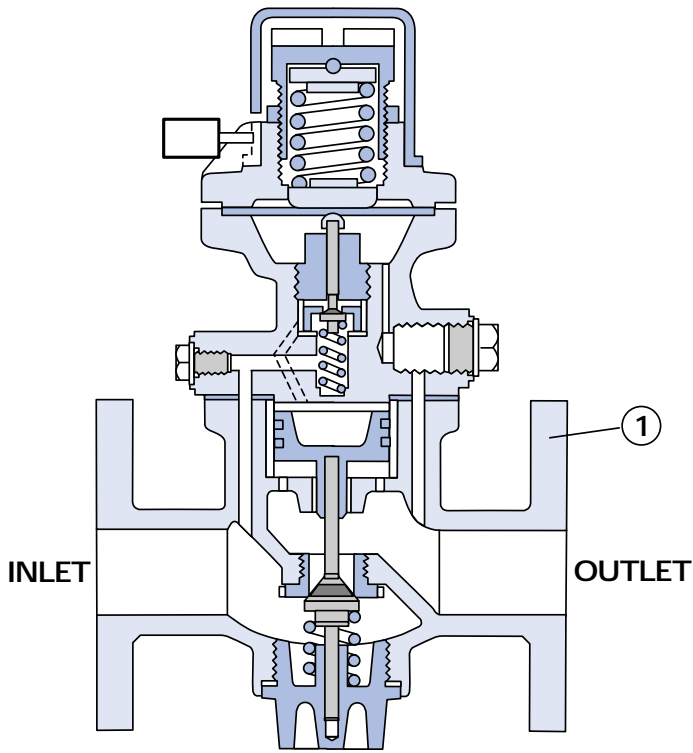

ITEM	PART
1	Body
2†	Main Valve
3†	Main Valve Seat
4	Bottom Plug
5	Piston
6*†	Piston Rings
7	Piston Liner
8	Piston Guide
17*†	Valve Body Top Joint
21†	Main Valve Spring
24*†	Bottom Plug Joint
25	Pilot Valve Top
26†	Pilot Valve
27†	Pilot Valve Plug
28*†	Pilot Valve Cap
29*†	Diaphragm
30	H.P. Port Plug
31†	Pilot Valve Spring
32	Pilot Valve Top Cover
33	Adjusting Spring
34	Adjusting Spring Bottom Plate
35	Adjusting Spring Top Plate
36	Adjusting Screw
37	Locking Ring
38	Padlock
42*†	Diaphragm Joint
43*†	H.P. Port Plug Joint
44	Cap Headed Screws
48†	Pilot Valve Head
49	L.P. Diaphragm
50	L.P. Screw Joint
51	L.P. Adaptor Flange
52	L.P. Top Cover
53	L.P. Push Rod
54	L.P. Top Cover Bolts
55	L.P. Top Cover Nuts
61	Top Cap
68*†	Pilot Valve Plug Joint
69	Remote Control Plug
70*†	Remote Control Plug Joint

Note: A variety of elastomeric or PTFE seats and gaskets are available to suit various applications.

\*Routine service pack; available from Safety Systems UK Ltd.

†Complete repair pack; available from Safety Systems UK Ltd.

Recommended inspection every 12 months.

## MATERIALS

ITEM	2042 & 2043 Bronze	2044 Carbon Steel	2045 Carbon Steel	2046 Carbon Steel
1	Bronze	Carbon Steel	Carbon Steel	Carbon Steel
2	Stainless Steel	Stainless Steel	Stainless Steel	Stainless Steel
3	Stainless Steel	Stainless Steel	Stainless Steel	Stainless Steel
4	Bronze	Bronze	Stainless Steel	Stainless Steel
5	Bronze	Bronze	Bronze	Stainless Steel
6	Bronze	Bronze	Bronze	Chrome Iron
7	Stainless Steel	Stainless Steel	Stainless Steel	Stainless Steel
8	Stainless Steel	Stainless Steel	Stainless Steel	Stainless Steel
17	NAF	NAF	NAF	NAF
21	Stainless Steel	Stainless Steel	Stainless Steel	Stainless Steel
24	NAF	NAF	NAF	NAF
25	Bronze	Bronze	Bronze	Steel
26	Stainless Steel	Stainless Steel	Stainless Steel	Stainless Steel
27	Stainless Steel	Stainless Steel	Stainless Steel	Stainless Steel
28	Brass	Brass	Brass	Brass
29	Stainless Steel	Stainless Steel	Stainless Steel	Stainless Steel
30	Bronze	Bronze	Bronze	Carbon Steel
31	Stainless Steel	Stainless Steel	Stainless Steel	Stainless Steel
32	Bronze	Bronze	Bronze	Carbon Steel
33	Steel	Steel	Steel	Steel
34	Brass	Brass	Brass	Brass
35	Brass	Brass	Brass	Brass
36	Bronze	Bronze	Bronze	Bronze
37	Bronze	Bronze	Bronze	Bronze
38	Brass	Brass	Brass	Brass
42	NAF	NAF	NAF	NAF
43	NAF	NAF	NAF	NAF
44	Steel	Stainless Steel	Stainless Steel	Stainless Steel
48	Stainless Steel	Stainless Steel	Stainless Steel	Stainless Steel
49	Bronze	Bronze	Bronze	N/A
50	Copper	Copper	Copper	N/A
51	Bronze	Bronze	Bronze	N/A
52	Bronze	N/A	N/A	N/A
53	Monel	Monel	Monel	N/A
54	Steel	Steel	Steel	N/A
55	Steel	Steel	Steel	N/A
61	Nylon	Nylon	Nylon	Nylon
68	Copper	Copper	Copper	Copper
69	Brass	Bronze	Bronze	Carbon Steel
70	NAF	NAF	NAF	NAF

## TECHNICAL SPECIFICATION - G4 reducing valves

Figure Number	Size Range mm	Connections	MATERIALS			PRESSURE Barg		TEMP.
			Body	Pilot Top	Main Valve Trim	Inlet Min-Max	Outlet Min-Max	Deg.C Min-Max
<b>2042</b>	15-50	Screwed	Bronze	Bronze	St Steel	0.7-35§	0.07-21	-20 to +260
†2042GN	15-50	Screwed	Bronze	Bronze	Nitrile	0.7-31	0.07-21	-20 to +100
†2042GV	15-50	Screwed	Bronze	Bronze	Viton	0.7-31	0.07-21	-18 to +150
†2042GP	15-50	Screwed	Bronze	Bronze	PTFE	0.7-35	0.07-21	-20 to +170
<b>2043</b>	15-50	Flanged	Bronze	Bronze	St Steel	0.7-35§	0.07-21	-20 to +260
†2043GN	15-50	Flanged	Bronze	Bronze	Nitrile	0.7-31	0.07-21	-20 to +100
†2043GV	15-50	Flanged	Bronze	Bronze	Viton	0.7-31	0.07-21	-18 to +150
†2043GP	15-50	Flanged	Bronze	Bronze	PTFE	0.7-35	0.07-21	-20 to +170
<b>2044</b>	65-150*	Flanged	Carbon St.	Bronze	St Steel	0.7-16π§	0.07-15π§	-20 to +220
<b>2044GP</b>	65-150*	Flanged	Carbon St.	Bronze	PTFE	1.0-16	0.07-15π	-20 to +170
<b>2045</b>	65-150*	Flanged	Carbon St.	Bronze	St Steel	0.7-35π§	0.35-21π§	-20 to +260
<b>2045GP</b>	65-150*	Flanged	Carbon St.	Bronze	PTFE	1.0-35	0.07-21§	-20 to +170
<b>2046</b>	15-100	Flanged	Carbon St.	Carbon St.	St Steel	0.7-42π§	0.35-21π§	-20 to +400
#2046GN	15-50	Flanged	Carbon St.	Carbon St.	Nitrile	0.7-31	0.35-21	-20 to +100
#2046GV	15-50	Flanged	Carbon St.	Carbon St.	Viton	0.7-31	0.35-21	-18 to +150
#2046GP	15-100	Flanged	Carbon St.	Carbon St.	PTFE	1.0-42	0.35-21π	-20 to +170

The pressures and temperatures in this table are the maximum for the model shown, restrictions apply as shown below.

Note: When outlet pressure is less than 0.35 Barg a low pressure top will be fitted.

† 'G' for gas duty can be replaced by 'O' for oxygen duty.

‡ When a stainless steel spring is fitted the maximum outlet pressure is 10.5 Barg.

# 15/20/25mm are all fitted into the 25mm body (1" flanges).

32/40/50mm are all fitted into the 50mm body (2" flanges).

π Air service restrictions see below.

§ Steam service restrictions see below.

\* A 150mm body can be offered with a restricted main valve to give a 125mm size flow rate.

### § - Steam Service Restrictions

Figure Number	Restriction on:	Restriction
<b>2042</b>	Inlet	25 Barg to 225°C/17 Barg to 260°C
<b>2043</b>	Inlet	25 Barg to 225°C/17 Barg to 260°C
<b>2044</b>	Inlet	13 Barg Max
<b>2044</b>	Outlet	12 Barg Max
<b>2045</b>	Inlet	65-150mm 25 Barg to 225°C/17 Barg to 260°C
<b>2045</b>	Outlet	65-100mm 21 Barg to 225°C/16 Barg to 260°C
<b>2045</b>	Outlet	125-150mm 12 Barg Max
<b>2046</b>	Inlet	42 Barg to 280°C/32 Barg to 400°C
<b>2046</b>	Outlet	125-100mm 12 Barg Max

### π - Air Service Restrictions

Figure Number	Restriction on:	Restriction
<b>2044</b>	Inlet	16 Barg to 120°C/13 Barg to 220°C
<b>2044</b>	Outlet	65-100mm 15 Barg to 120°C/12 Barg to 220°C
<b>2044</b>	Outlet	125-150mm 12 Barg
<b>2045</b>	Inlet	65-150mm 35 Barg to 170°C/17 Barg to 260°C
<b>2045</b>	Outlet	65-100mm 21 Barg to 170°C/16 Barg to 260°C
<b>2045</b>	Outlet	125-150mm 12 Barg Max
<b>2046</b>	Inlet	42 Barg to 280°C/32 Barg to 400°C
<b>2046</b>	Outlet	125-100mm 12 Barg

## DIMENSIONS

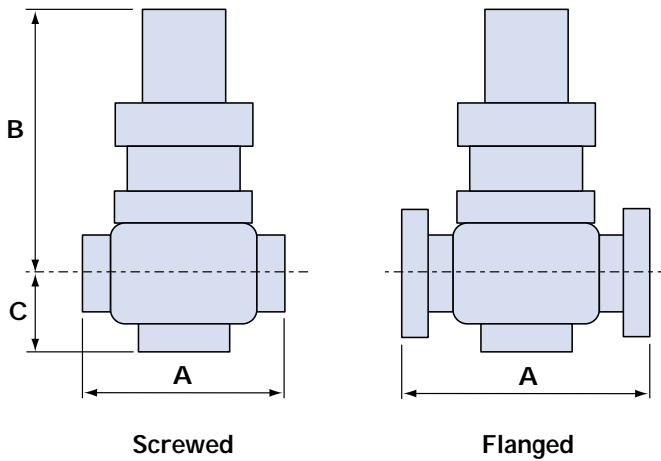

### CONNECTION OPTIONS

<b>Screwed</b> BSP**	API/NPT
<b>Flanged</b> BS4504 PN**	ANSI, BS10

\*\*Standard item.

Valve type	Size	Connection	A			B		C		Weight kg
			ins	mm	DIN flange mm	ins	mm	ins	mm	
<b>Fig 2042</b> <b>Screwed</b> <b>Bronze</b>	15mm	½" BSP	4.125	105	–	8	203	2.375	60	6
	20mm	¾" BSP	4.125	105	–	8.25	210	2.5	64	6.8
	25mm	1" BSP	4.5	114	–	8.375	213	2.625	67	7
	32mm	1¼" BSP	4.875	124	–	9.625	244	3	76	10.8
	40mm	1½" BSP	5.25	133	–	9.875	251	3.125	79	12.7
	50mm	2" BSP	6.375	162	–	10.25	260	3.25	83	15.4
<b>Fig 2043</b> <b>Flanged</b> <b>Bronze</b>	15mm	½"	5.5	140	130*	8	203	2.375	60	8
	20mm	¾"	5.625	143	150*	8.25	210	2.5	64	8.6
	25mm	1"	6.75	171	160*	8.375	213	2.625	67	9
	32mm	1¼"	7	178	180*	9.625	244	3	76	13.6
	40mm	1½"	7.5	191	200*	9.875	251	3.125	79	16.3
	50mm	2"	8.5	216	230*	10.25	260	3.25	83	20.8
<b>Fig 2044</b> <b>Flanged</b> <b>Carbon</b> <b>Steel</b> <b>(Brz. top)</b>	65mm	2½"	10	254	254	11.25	286	5.125	130	38
	80mm	3"	11.25	286	286	11.25	286	5.75	146	56
	100mm	4"	13.5	343	343	12.75	324	7	178	80
	125mm	6"	16.5	419	419	16.5	419	9.75	248	174
	150mm	6"	16.5	419	419	16.5	419	9.75	248	174
<b>Fig 2045</b> <b>Flanged</b> <b>Carbon</b> <b>Steel</b> <b>(Brz. top)</b>	65mm	2½"	10	254	254	11.25	286	5.125	130	38
	80mm	3"	11.25	286	286	11.25	286	5.75	146	56
	100mm	4"	13.5	343	343	12.75	324	7	178	80
	125mm	6"	16.5	419	419	16.5	419	9.75	248	174
	150mm	6"	16.5	419	419	16.5	419	9.75	248	174
	<b>Fig 2046</b> <b>Flanged</b> <b>Carbon</b> <b>Steel</b> <b>(C.S. top)</b>	15mm	1"	6.75	171	230†	8.375	213	2.75	70
20mm		1"	6.75	171	230†	8.375	213	2.75	70	13.5
25mm		1"	6.75	171	230†	8.375	213	2.75	70	13.5
32mm		2"	9	229	229	10.5	267	3.5	89	26.3
40mm		2"	9	229	229	10.5	267	3.5	89	26.3
50mm		2"	9	229	229	10.5	267	3.5	89	26.3
65mm		2½"	10	254	254	11.25	286	5.125	130	42
80mm		3"	11.25	286	286	11.25	286	5.75	146	52
100mm		4"	13.5	343	343	12.75	324	7	178	87

Face to face dimensions are in accordance with

\*Din 3300 (PN40)

†Din 3300 (PN64)

## 'IN SERIES' INSTALLATIONS

Multiple valves installed 'In Series' should be considered for applications when high pressure drops are required. If the required outlet pressure is less than the minimum shown in the charts two valves can be used.

An 'In Series' installation should be designed to drop the pressure in at least two steps/stages.

## 'IN PARALLEL' INSTALLATIONS

Multiple valves can be installed as an 'in parallel' system when the system has a very large variation in the required capacity. On such a system one large and one small valve should be installed, with a combined capacity greater than the maximum required demand, the smaller valve having a capacity just greater than the minimum required demand.

Setting the smaller valve slightly higher than the larger valve, will ensure that the larger valve is closed at low flow rates. Increasing demand will then open the larger valve as outlet pressure falls to its set point.

A typical diagram is shown (using close coupled parallel slide isolating valves).

### 'IN SERIES' INSTALLATION

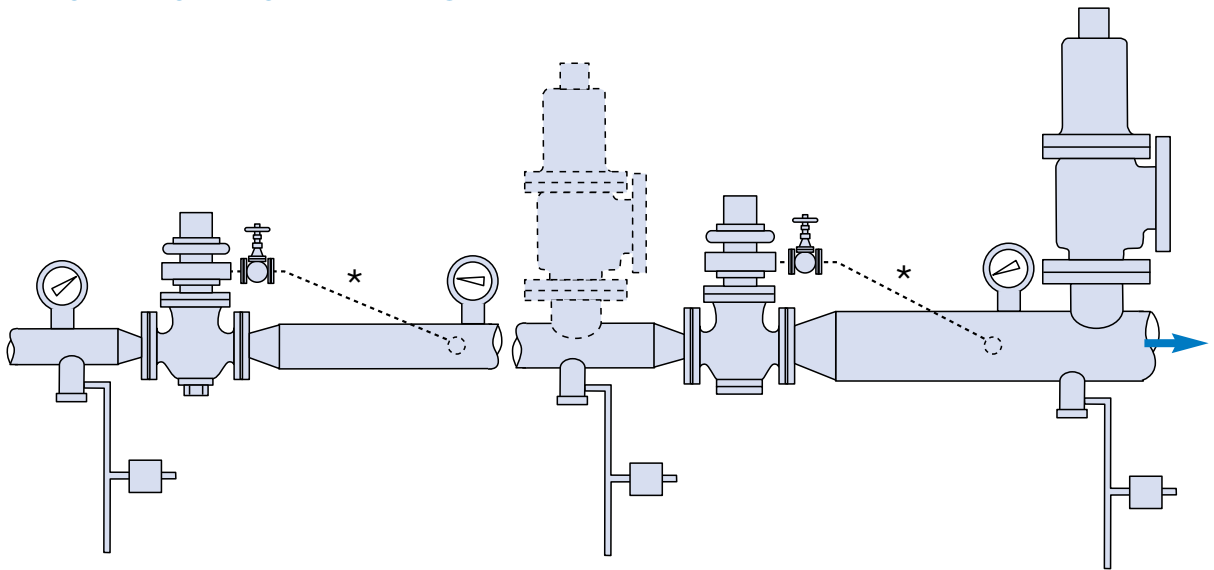

### 'IN PARALLEL' INSTALLATION

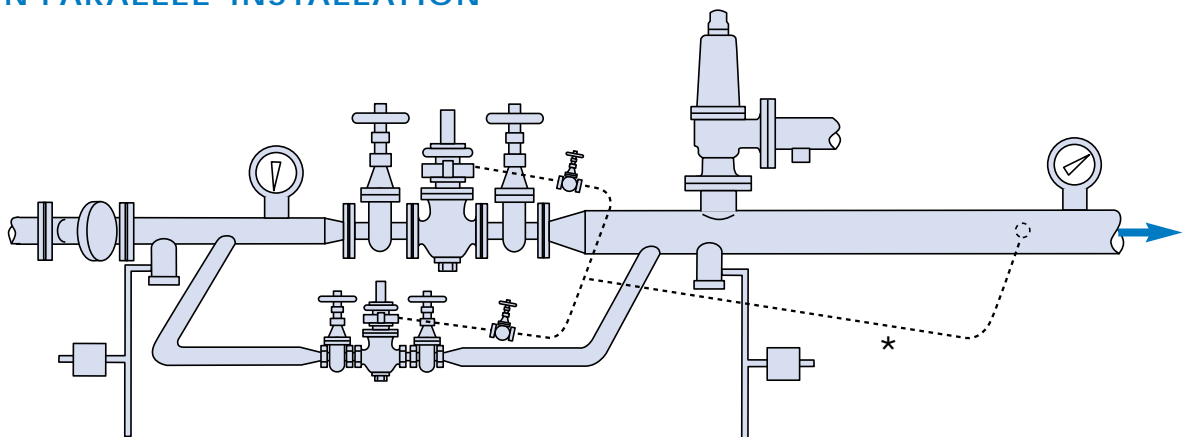

\* Balance lines are only required on some steam applications, they are not required on air/gas applications, see page 38.

## INSTALLATION

### TYPICAL STEAM REDUCING VALVE INSTALLATION USING GLOBE STOP VALVES

\*(Note: if you use parallel slide stop valves, they can be close coupled to the G4.)

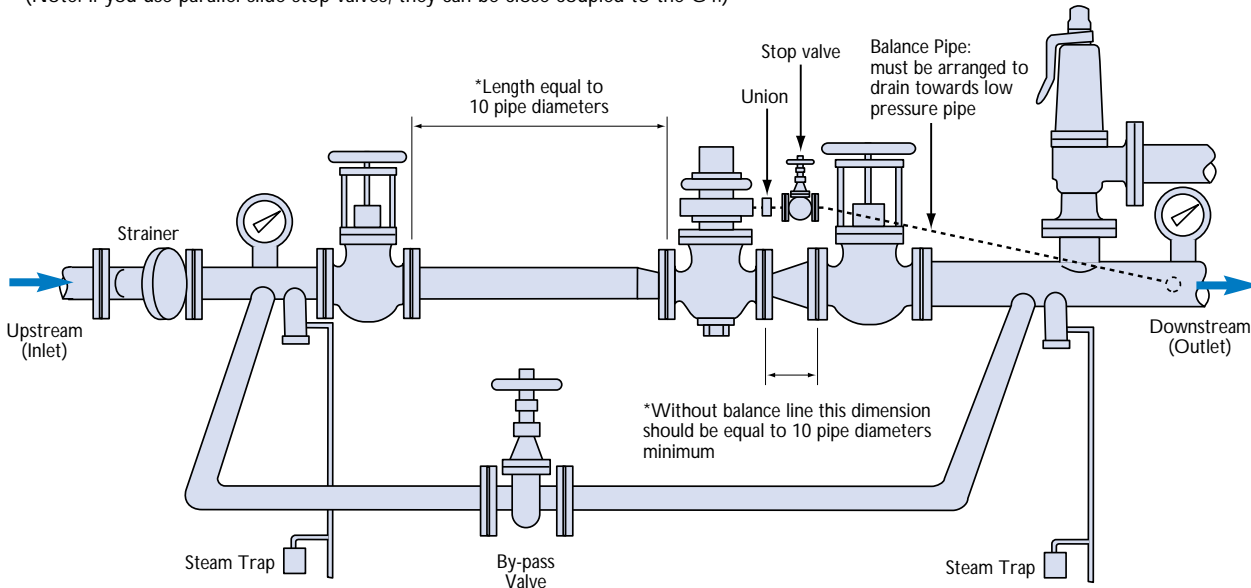

The majority of troubles experienced with pressure regulators can be attributed to installation faults. These can be avoided by giving attention to the following points:

#### Sizing

The correct sizing and layout of regulators, pipework, stop valves, strainers and other fittings is extremely important for good performance.

#### Inlet Strainer

Dirt, grit and pipe scale are common causes of regulator failure. A strainer of upstream pipe size should be fitted at least 10 pipe diameters before the regulator.

#### Steam Traps

Steam reducing valve stations should have steam traps fitted on the inlet and outlet pipes, to prevent build up of condensate in the regulator, particularly under no flow conditions.

#### Safety Valve

Every installation should be fully protected against regulator failure by a safety valve. Care should be taken that the discharge from such a valve cannot cause damage to property or create a hazard to personnel. The safety valve should be sized to pass the maximum capacity of the regulator.

#### Pipe work

All pipework and fittings should be properly supported and free from any strain or vibrations which could affect their correct operation. All flanges should be correctly aligned and joints carefully fitted to avoid blockage of valve ports.

If a jointing compound is used it should not be allowed to foul the internal ports or working parts of the valve.

#### Balance Pipe (Steam applications only)

A balance pipe should be fitted when the reduced pressure is 55% or less of the inlet pressure, or to help counteract difficult turbulent downstream conditions caused by pipe fittings, valves or bends. The method of connecting the balance pipe to the reducing valve is shown in the sketch. It should drain downwards and be connected into the side of the downstream pipe at a point where smooth flow occurs (preferably downstream of the safety valve). Where isolation of the regulator is desired, a stop valve should be fitted in the balance line.

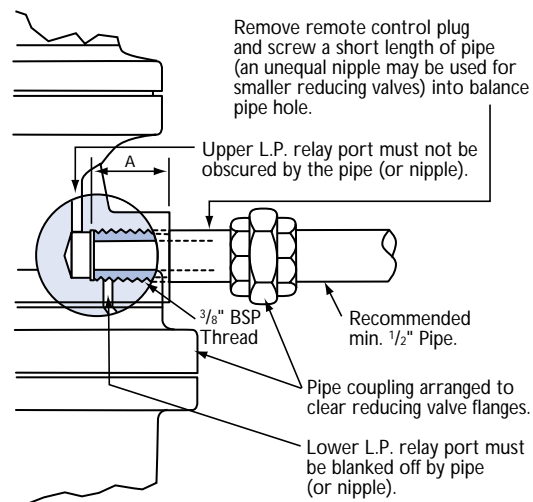

'A' dimension must be  $\frac{15}{16}'' \pm \frac{1}{16}''$  on all stainless steel valves or CS Fig 2046. All other valves with bronze pilot tops, the pipe should penetrate 1" minimum.

### Before putting a regulator into service

Prior to installing the valve all pipes should be thoroughly blown-through to remove any dirt, grit or pipe scale. Additional cleaning can be done by removing the regulator bottom plug, main valve and spring, and then carefully opening the inlet stop valve by a small amount. Remove any dirt lodged in the valve body and replace all parts.

## SETTING

### Setting under no flow conditions

This is the more accurate method and may be carried out as follows:

1. Any condensate remaining in the pipeline should be removed by first applying a little tension to the regulator adjusting spring (by rotating the adjusting screw clockwise for a few turns) and then slowly opening the outlet and inlet stop valves. When the downstream pressure starts to rise, close the inlet stop valve and remove all tension from the regulator adjusting spring.
2. Close the outlet stop valve and slowly open the inlet stop valve. Wait for about one minute to confirm that the reduced pressure is maintained at zero. This is a check that the regulator gives 'dead-tight' shut-off under no flow conditions.
3. Slowly raise the reduced pressure (by rotating the regulator adjusting screw clockwise) until the desired pressure is obtained. (Do not forget to set the safety valve 15% above the reduced pressure, if necessary.) The valve is now correctly set and the adjusting screw should be locked with the lock-nut provided.
4. Slowly bring the outlet stop valve to 'full open' and apart from a possible initial 'fall back' of the reduced pressure (whilst the systems is warmed through) the regulator should continue to maintain the reduced pressure.

### Setting On Flow

With the inlet and outlet stop valves closed, apply a little tension to the regulator adjusting spring (by rotating the adjusting screw clockwise for a few turns). Open the inlet and all downstream stop valves and then wait until all condensate has been removed and the system properly warmed through. Then slowly raise the reduced pressure by clockwise rotation of the adjusting screw until the desired reduced pressure is obtained. (Do not forget to set the Safety Valve, if necessary.) If the flow is varying,

some trial and error may be necessary before the correct setting is finally achieved. The reduced pressure under no-flow conditions should be checked as soon as convenient.

We strongly recommend that the inlet strainer and reducing valve should be cleaned out one week after commissioning, and the strainer and steam traps checked at regular intervals thereafter.

### Outlet Pressure Regulation

Up to 80mm (3") size  $\pm 1/2\%$  of outlet pressure  
[ $\pm 0.035$  Barg ( $1/2$  Psig) below 6.9 Barg (100 Psig)]

Above 80mm (3") size  $\pm 1\%$  of outlet pressure  
[ $\pm 0.07$  Barg (1 Psig) below 6.9 Barg (100 Psig)]

Pressure rise at dead end (steam only) = 1%.

## SPRING SELECTION

If possible it is advisable to select a spring which has at least 10% additional adjustment above the required set pressure. As can be seen from the chart, the springs have overlapping ranges. Where possible the spring with the lowest range should be selected.

15-100mm (1/2" - 4") VALVES		
Barg	(Psig)	Colour Code
0.07-3.5	(1-50)	Yellow
0.7-7.0	(10-100)	Black
2.8-10.5	(40-150)	White
3.5-14.0	(50-200)	Green
7.0-21.0	(100-300)	Red
150mm (6")* VALVES		
Barg	(Psig)	Colour Code
0.35-1.4	(5-20)	Red
0.7-3.5	(10-50)	Yellow
2.8-7.0	(40-100)	Black
3.5-12.0	(50-175)	Green

\*A 150mm body can be offered with a restricted main valve to give a 125mm size flow rate.



## SIZING

The G4 Pressure Regulator can give its best performance when correctly sized to match the maximum demand of the system. It is therefore important that the size of regulator is decided from the known or estimated consumption and never fitted just as a line size valve. It is useful to remember that the G4 is a full lift, high capacity valve and correctly sized will almost invariably be smaller than the size of the pipe work.

The valve sizing charts illustrate that the maximum capacity occurs when the outlet pressure is less than 55% of the inlet pressure (critical pressure drop sizing). When the outlet pressure is above 55% sub critical flow occurs and the capacity will be reduced.

**Critical pressure drop sizing is only true when both the inlet and outlet pipework is sized correctly in accordance with our pipe sizing charts (see page 70).**

It is important to remember that the outlet pipe is invariably larger than the inlet pipe, in order to pass the same quantity of steam, air or gas at a lower pressure.

**Note** Undersized pipe work and fittings cause unnecessary and uncontrolled pressure losses and are a major cause of unstable control.

### Capacity Variations

The sizing charts give the maximum capacities which can be handled by the regulator for the given inlet and outlet pressures.

For trouble free operation the minimum flow rate should be considered to be 10% of the maximum.

### Steam

If no steam capacity is given, size the regulator based on the maximum flow which can be achieved through the inlet pipe, according to our pipe sizing charts.

Alternatively, if the maximum heat requirement of the system is known, the following approximate relationship can be used.

Steam Capacity:

$$\text{Kg/h} = \text{Kcals} \div 554$$

$$\text{kg/h} = \text{kW} \times 0.6446$$

$$\text{lbs/h} = \text{B.T.U.'s/h} \div 1000$$

### Superheated Steam

If the steam temperature is greater than the saturated steam temperature, the capacities shown in our tables will need to be reduced.

DEGREES OF SUPERHEAT		
°C	°F	Factor
0 to 10	0 to 50	multiply by 0.96
10 to 50	50 to 100	multiply by 0.92
50 to 75	100 to 150	multiply by 0.89
75 to 100	150 to 200	multiply by 0.86
100 to 150	200 to 300	multiply by 0.82

### Air and Gases

For gases other than air, divide the chart air capacity by  $\sqrt{\text{SG}}$  (SG of Air = 1) to give the equivalent gas capacity.

### Other Temperatures

The air/gas capacity tables are based on air at 15°C. If the actual flowing temperature is different, the chart capacity will need to be divided by  $\sqrt{\frac{T}{288}}$

Where: T= flowing temperature °C + 273°k.

## SIZING EXAMPLE

### Requirement

Fluid - Steam @ 184°C  
 Inlet Pressure - 10 Barg  
 Outlet Pressure - 5.5 Barg  
 Required Capacity - 1100 kg/h

### Sizing

Refer to the sizing chart on page 68. At an inlet pressure of 10 Barg and at an outlet pressure of 5.5 Barg.

The first valve to pass more than 1100 kg/h is the 32mm (1¼"), which will pass 1489kg/h.

### Selection

Refer to page 29 and page 35.

We can choose between figures 2042, 2043 or 2046. The choice will then depend on the customer's requirements on connections and materials. The most economical choice would be the 2042 screwed bronze valve.

At 5.5 Barg a standard top is acceptable (ref. page 32), only one diaphragm is required (see opposite) and the black spring (ref. page 81) should be fitted with a range of 0.7 to 7.0 Barg.

### Inlet Pipe Size

Refer to page 70, at 10 Barg the smallest pipe to pass our required flow of 1100kg/h is 50mm (2").

### Outlet Pipe Size

Refer to page 70, at 5.5 Barg the smallest pipe to pass our required flow of 1100kg/h is 65mm (2 ½").

## SPARES

### Routine Service Pack:

1 Diaphragm  
 1 Set of Piston Rings  
 1 Pilot Valve Cap  
 1 Set of Joints

### Complete Repair kit:

1 Diaphragm  
 1 Set of Piston Rings  
 1 Pilot Valve Assembly  
 1 Main Valve  
 1 Main Valve Seat  
 1 Main Valve Spring  
 1 Set of Joints  
 1 Pilot Valve Cap



Each carton of spares contains a leaflet, which not only identifies the parts supplied, but also has a recommended list of 'check-points' to help identify common causes of reducing valve trouble.

## DIAPHRAGMS

One diaphragm is required for reduced pressures up to 10.5 Barg (150 Psig), but two are required for reduced pressure above this figure.

## SURPLUS/MAINTAINING VALVES

The 'G4 surplus' valve can also be described as a 'pressure maintaining' or 'pressure sustaining' valve.

In these days of high energy costs and environment emission controls, steam and air systems can be very expensive to install and run. Often most industrial applications need steam or air for the main process plant and it is critical to maintain the supply to these processes. Additionally, such plants will also have other demands of a less critical nature such as compressed air lines, heating and cleaning systems.

Obviously two separate systems could be employed, providing that the necessary funds are available to install and run both. Alternatively the secondary and less critical applications can be run from the surplus generated from the main system. However, during periods of extreme demand the main process could be starved of steam or air, resulting in production disruption and product loss. (See figure 1).

### The solution is to fit a 'G4 surplus' valve.

The 'G4 surplus' valve is designed to be installed in branch lines to non-essential equipment (see figure 1), to maintain the upstream pressure, thus maintaining the supply to the more vital process and subsequently maintaining production from the system. Alternatively to dump flow surplus to requirements, to a drain or atmosphere.

Additionally if the pressure in a boiler or air accumulator is allowed to fall too low, a lot of energy will be required to build up the pressure once again (see figure 2).

### The solution is to fit a 'G4 Maintaining' valve.

The 'G4 Maintaining' valve is designed to be installed in the main pipeline from the boiler or an air compressor (see figure 2), to maintain the pressure in the boiler or accumulator, thus preventing the boiler or accumulator from becoming exhausted.

### Operation

The inlet pressure is directed under the diaphragm. A small increase in pressure above the set pressure lifts the diaphragm and opens the pilot valve, which in turn opens the main valve. Subsequently when excess demand drops the pressure below the required level, the adjusting spring will overcome the pressure under the diaphragm and close the pilot valve. This in turn causes the main valve to close, thus cutting the surplus supply and/or maintaining pressure in the main line, boiler or accumulator.

This duty and valve type is known by many names. As can be seen in this text the valve 'maintains' or 'sustains' pressure in the main line, boiler or accumulator and can use 'surplus' pressure for non-essential services.

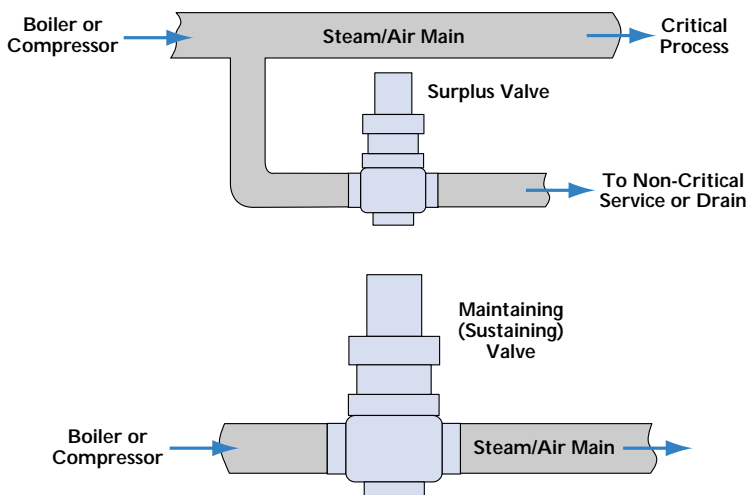
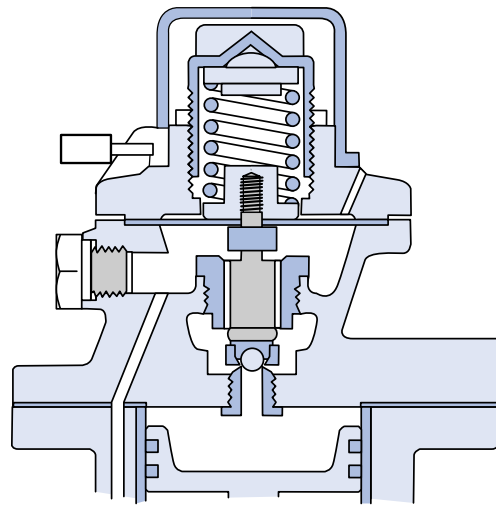

**Figure 1**

When the G4 surplus valve is closed, the full flow from boiler/compressor goes to the critical process.

**Figure 2**

When the G4 maintaining valve is closed, the full flow from boiler/compressor is stopped and the minimum pressure of the boiler/accumulator is maintained.

## G4 SURPLUS/MAINTAINING VALVE SELECTION

### Example 1: Surplus duty (see figure 1, page 42)

A steam boiler normally working at a pressure of 10 Barg, delivers steam to a critical process which must not fall below 8 Barg (closing pressure) in order to preserve correct operation. The excess (surplus) capacity produced can be used for a non-critical service. If this non-critical service requires 3500 Kg/h of saturated steam, what size of G4 surplus valve will be required?

A surplus valve is normally sized on the minimum allowable pressure drop across the valve ie: at an equivalent pressure equal to the maximum outlet setting of the valve. Looking at page 51 and the 10 Barg inlet pressure, the maximum outlet setting is 9 Barg. The required flow is 3500kg/h by 0.48 and it can be seen that the 80mm (3") valve will pass a maximum flow of 3771kg/h.

### Example 2: Pressure maintaining duty (see figure 2, page 42).

A steam boiler, normally working at a pressure of 10 Barg, delivers steam to a process. It is determined that the boiler pressure must not fall below 8 Barg. The process normally requires 3500 Kg/h of saturated steam, what size of G4 maintaining valve will be required?

Selecting a pressure maintaining valve is the same as selecting a surplus valve, therefore follow the same sizing procedure.

## SURPLUS/MAINTAINING VALVE PERFORMANCE

A small pressure rise (accumulation) above the set point is required to fully open the valve, and a small pressure drop (regulation) below the set pressure is required to close the valve. It is therefore important to set the valve higher than the pressure at which the valve must be closed, to allow for this regulation.

In the above examples the valve must be set at a minimum of 8.15 Barg. This allows for the regulation of 0.15 Barg to ensure the valve is fully closed at 8 Barg. It can also be seen that the valve will be fully open by 8.35 Barg (i.e. 0.2 Barg accumulation above the set point of 8.15 Barg).

### Spring selection

If possible, it is advisable to select a spring which has at least 10% adjustment above the required set pressure. As can be seen from the chart, the springs have overlapping ranges and therefore, where possible, the spring with the lowest pressure range should be selected.

In the examples we require a spring for a pressure of 8.15 Barg (ideally plus 10%, say 9 Barg). As can be seen the white, green and red springs can do this pressure, however the white spring should be selected as it has the lower range.

### Valve selection

Referring to the charts on page 29 and page 44, it can be seen that the figures 2044 and 2045 are suitable for the given conditions.

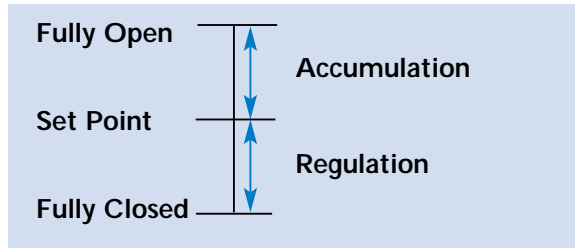

Closing Pressure		Accumulation	Regulation
Barg	(Psig)	Barg (Psig)	Barg (Psig)
0.35 - 3.5	(5 - 50)	0.10 (1.5)	0.04 (0.5)
3.5 - 7.0	(50 - 100)	0.10 (1.5)	0.10 (1.5)
7.0 - 10.3	(100 - 150)	0.20 (3.0)	0.15 (2.0)
10.3 - 20.7	(150 - 300)	0.50 (7.0)	0.70 (10.0)

Spring Colour Code	Spring Pressure Range	
	Barg	(Psig)
Yellow	0.35 - 3.5	(5 - 50)
Black	0.7 - 7.0	(10 - 100)
White	2.8 - 10.3	(40 - 150)
Green	3.5 - 14.0	(50 - 200)
Red	7.0 - 20.7	(100 - 300)

## DIAPHRAGMS

For pressures above 10.3 Barg (150 Psig) two diaphragms must be fitted. Below this pressure only one diaphragm is fitted.

## TECHNICAL SPECIFICATION - G4 SURPLUS/MAINTAINING VALVES

Figure No.	2042	2043	2044	2045
<b>Size</b>	15 – 50mm (½ – 2ins)	15 – 50mm (½ – 2ins)	65 – 100mm (2½ – 4ins)	65 – 100mm (2½ – 4ins)
<b>Connections</b>	Screwed	Flanged	Flanged	Flanged
<b>Material</b>	Bronze	Bronze	Carbon Steel	Carbon Steel
<b>Max. inlet pressure</b>	20.7 Barg (300 Psig)	20.7 Barg (300 Psig)	20.7 Barg (300 Psig)	20.7 Barg (300 Psig)
<b>Min. inlet pressure</b>	0.7 Barg (10 Psig)	0.7 Barg (10 Psig)	1.03 Barg (15 Psig)	1.03 Barg (15 Psig)
<b>Temperature range</b>	<b>Min.</b>	<b>Max.</b>	<b>Max.</b>	<b>Max.</b>
Stainless steel seat	-20°C (-68°F)	260°C (500°F)	260°C (500°F)	220°C (430°F) 260°C (500°F)
Nitrile seat	-20°C (-68°F)	100°C (212°F)	100°C (212°F)	NA NA
Viton seat	-18°C (-64°F)	150°C (302°F)	150°C (302°F)	NA NA
PTFE seat	-20°C (-68°F)	170°C (338°F)	170°C (338°F)	170°C (338°F) 170°C (338°F)

# Class T Pressure Reducing Valve

The Class T balanced direct acting pressure regulator is designed for use on installations that have varying inlet pressures and capacities, and require positive shut-off under "no flow" conditions.

The standard valve is suitable for controlling air, gas and water. Alternative seals and diaphragms need to be fitted for oil duty.

## OPERATION

The Class T pressure regulator is operated by a spring loaded piston and has a balanced main valve which ensures that the outlet dead-end pressure is unaffected by changes of inlet pressure.

The valve is opened by the load on the adjusting spring and closed by reduced pressure on the underside of the diaphragm. Under normal working conditions, the balance of these two forces gives the degree of valve opening for the required reduced pressure.

## FEATURES AND BENEFITS

- Fully balanced piston - allows a constant outlet pressure to be maintained, irrespective of varying inlet pressure.
- Soft disc - for positive shut-off.
- Self actuation/regulation - requires no external power source.
- Simple design - enables the valve to be easily maintained and serviced, without removal from the line.
- Minimum variation between 'flow' and 'no-flow' pressure.

## CE MARKING

The Class T has been certified to the requirements of the PED (Category II). Valve sizes below 32mm (1¼ inch), do not require, and hence, cannot be CE marked.

## TECHNICAL SPECIFICATION

**Size** 15, 20, 25, 32, 40, 50 mm  
(½, ¾, 1, 1¼, 1½, 2 inch)

**Connections** Screwed BSP parallel, NPT.  
Flanged BS4504 PN25/40.  
BS 10 table 'H', ANSI 150.

**Material** Bronze.

**Temperature Range**  
Min: -20°C Max: air/water 100°C / oil 90°C.

**Maximum Inlet Pressure** 40 Barg.

**Maximum Outlet Pressure\*** 13.8 Barg.

**Minimum Outlet Pressure\***

MIN. OUTLET	INLET PRESSURE RANGE
0.35 Barg	up to 6.9 Barg
5% of inlet	6.9 to 20.7 Barg
10% of inlet	above 20.7 Barg

\* Setting including rise at dead end (see pages 56, 73 and 75).

## SPRING SELECTION

DEAD END PRESSURE SETTING RANGE (Barg)	DEAD END PRESSURE SETTING RANGE (Psig)	COLOUR CODE
0.35 to 0.7	5 to 10	Dark Green
0.7 to 1.4	10 to 20	Light Green
1.4 to 2.8	20 to 40	Orange
2.8 to 5.5	40 to 80	Brown
5.5 to 8.3	80 to 120	Blue
8.3 to 13.8	120 to 200	Red

## PARTS

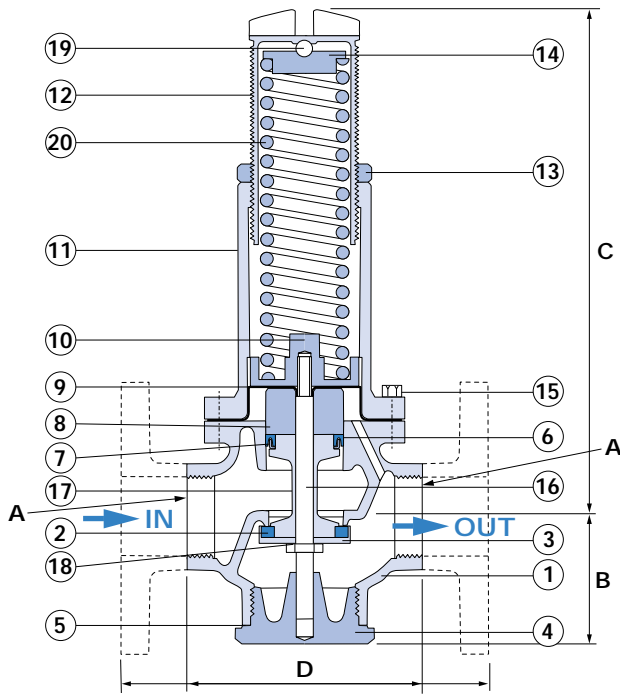

ITEM	PART	MATERIAL
1	Body	Bronze
2†	Valve Disc*	Rubber/PTFE
3	Disc Holder	Brass
4	Bottom Plug	Bronze
5†	Bottom Plug Joint	NAF
6†	H. P. Seal	Rubber
7	H. P. Seal Ring	Brass
8	Distance Piece	Brass
9†	Rolling Diaphragm	Rubber
10	Piston	Brass
11	Spring Chamber	Bronze
12	Adjusting Screw	Bronze
13	Adjusting Screw Ring	Brass
14	Spring Plate	Brass
15	Set Screws	Plt. Steel
16	Valve Stem	Bronze
17	Valve Stem Sleeve	Bronze
18	Valve Stem Joint	NAF
19	Adjusting Screw Ball	St. St.
20	Spring	Plt. Steel

\* Valve discs are normally rubber, however PTFE discs should be specified when the inlet pressure is above 17.2 Barg or the outlet pressure is above 8.2 Barg.

†Set of seals - water/gas or oil duty; available from Safety Systems UK Ltd.

Recommended inspection every 12 months

## DIMENSIONS

### Screwed

SIZE	DN15	DN20	DN25	DN32	DN40	DN50
<b>A BSP</b>	1/2"	3/4"	1"	1 1/4"	1 1/2"	2"
<b>B</b>	45	48	56	68	68	79
<b>C</b>	162	184	222	232	292	324
<b>D</b>	76	89	111	124	133	165
<b>Kg</b>	2	3	4	6	8	11

### Flanged

SIZE	DN15	DN20	DN25	DN32	DN40	DN50
<b>A</b>	1/2"	3/4"	1"	1 1/4"	1 1/2"	2"
<b>B</b>	57	57	61	67	70	83
<b>C</b>	162	184	222	232	292	324
<b>D</b>	130	150	160	180	200	230
<b>Kg</b>	3	5	6.5	8.5	13	17

All dimensions in mm.

# Class TH Pressure Reducing Valve

The Class TH High Pressure Reducing Valve has been developed to increase the outlet pressures available from the Class T range of valves.

The existing range utilises diaphragm technology to regulate the closing pressure. This technology relies on the flexibility of rolling rubber diaphragms, which limit the maximum outlet pressure due to the strength of the rubber.

Within the Class TH High Pressure Reducing Valve, the diaphragm is replaced with a piston (Y). The outlet pressure is sensed up through port (X) to the underside of the piston. This design allows much higher pressures to be accommodated and is less susceptible to pressure spikes and water hammer.

## OPERATION

The Class TH pressure regulator is operated by a spring loaded piston and has a balanced main valve which ensures that the outlet dead-end pressure is unaffected by changes of inlet pressure.

The valve is opened by the load on the adjusting spring and closed by reduced pressure on the underside of the piston. Under normal working conditions, the balance of these two forces gives the degree of valve opening for the required reduced pressure.

## FEATURES AND BENEFITS

- Fully balanced piston - allows a constant outlet pressure to be maintained, irrespective of varying inlet pressure.
- Soft disc - for positive shut-off.
- Self actuation/regulation - requires no external power source.
- Simple design - enables the valve to be easily maintained and serviced without removal from the line.
- Minimum variation between 'flow' and 'no-flow' pressure.

## TECHNICAL SPECIFICATION

<b>Size</b>	25, 40 and 50 mm (1, 1½ and 2 inch)
<b>Connection</b>	Flanged BS4504 PN16/40.
<b>Material</b>	Bronze
<b>Temperature Range</b>	-20 to 100°C
<b>Maximum Inlet Pressure</b>	40 Barg
<b>Maximum Outlet Pressure*</b>	20 Barg
<b>Minimum Outlet Pressure*</b>	3 Barg

\* Setting including rise at dead end (see pages 56 and 74).

## CE MARKING

The Class TH has been certified to the requirements of the PED (Category II). Valve sizes below 32mm (1¼ inch), do not require, and hence, cannot be CE marked.

## SPRING SELECTION

Dead End Setting Barg	Spring Number			Springs Colour Code
	DN25 (1")	DN40 (1.5")	DN50 (2")	
3 to 15	C2957-425	C2954-425	C2960-425	White
1 to 7	-	C3197-425	C3196-425	Purple
>7 to 20	C3019-425	C2959-425	C2961-425	Yellow

Dead End Setting = Flowing outlet pressure + Rise to dead end



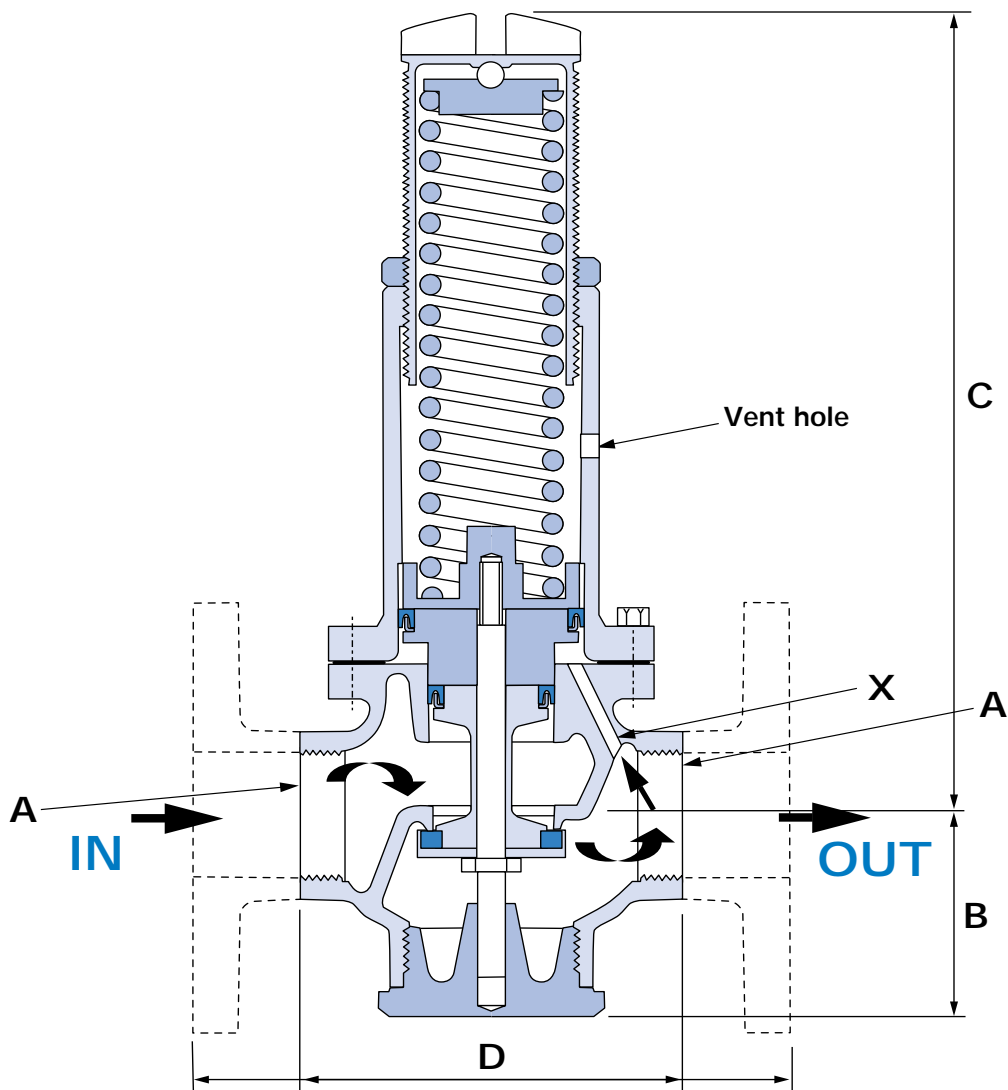

## DIMENSIONS

### Screwed

SIZE	DN25	DN40	DN50
A BSPF	1"	1½"	2"
B	56	68	79
C	222	292	324
D	111	133	165
Kg	4	8	11

### Flanged

SIZE	DN25	DN40	DN50
A	1"	1½"	2"
B	61	70	83
C	222	292	324
D	160	200	230
Kg	6.5	13	17

All dimensions in mm.

# Bailey B Pressure Reducing Valve

The Bailey B series of steam pressure reducing and regulating valves are single seated, spring loaded, direct acting diaphragm-actuated valves. This series automatically reduces a high inlet pressure to a lower delivery pressure and maintains that lower pressure within reasonably close limits.

They are designed and built to withstand long periods of service. The simplicity of design aids the ease of maintenance when it is required.

## OPERATION

The steam enters at the inlet port (upstream), passing through the strainer screen and seat to the valve outlet (downstream). The amount of valve opening is controlled by the diaphragm.

The diaphragm moves in accordance with the forces exerted upon it by the main spring and the downstream pressure acting on the underside of the diaphragm, which opposes the main spring.

When the force exerted by the main spring is greater than that exerted by the downstream pressure, the valve is pushed off its seat by means of the push rod, thus allowing steam to flow from inlet to outlet. When the force exerted by the downstream pressure is greater than that exerted by the main spring, the diaphragm will return to a horizontal position. The piston spring, assisted by the steam pressure, will force the valve against the seat, thus cutting off the flow.

## FEATURES AND BENEFITS

- Pressure adjustment can be changed easily by loosening the lock nut and simply turning the adjustment screw - clockwise to increase, and anti-clockwise to decrease the delivery (outlet) pressure.
- Valves are fitted with a carefully matched brass piston and cylinder with a composition seat disc insert for tight shut-off.
- The working parts of the valve are protected by a self supporting inbuilt monel strainer screen which maximises operability and increase reliability. It is easily removed for cleaning.
- The rugged but simple design of the Bailey B regulator lends itself to easy maintenance and repair. The inner valve assembly is easy to clean or replace by loosening the large hex head bottom plug. All major repairs can normally be made without removing the valve from the line.
- Self activation/regulation - requires no external power source.

## TECHNICAL SPECIFICATION

<b>Size</b>	15, 20, 25, 32, 40, 50mm (½", ¾", 1", 1¼", 1½", 2")
<b>Connection</b>	Screwed BSP parallel female.
<b>Material</b>	Bronze.
<b>Temperature Range</b>	-20 to 204°C.
<b>Maximum Inlet Pressure</b>	Steam 17.2 Barg.
<b>Maximum Outlet Pressure</b>	Steam 10.3 Barg.
<b>Minimum Outlet Pressure*</b>	Steam 0.7 Barg

Outlet pressure should not be less than 10% of the inlet pressure.

\* Setting including rise at dead end (see page 56).

## SPRING SELECTION

Size	Spring Ranges Maximum Working Range		Part Number
	Barg	Psig	
DN15 (½")	0.14-2.07	2-30	110
	0.69-3.45	10-50	111
	2.07-8.62	30-125	113
	3.45-10.34	50-150	8805
DN20 (¾")	0.14-1.39	2-20	110
	0.69-2.41	10-35	111
	2.07-5.17	30-75	113
	3.45-6.70	50-100	8805
DN25 (1")	0.14-1.39	2-20	110
	0.69-2.41	10-35	111
	2.07-5.17	30-75	113
	3.45-6.70	50-100	8805
DN32 (1¼")	0.14-1.03	2-15	5356
	0.69-2.07	10-30	737
	1.36-4.14	20-60	1163
	3.79-6.70	55-100	1303
DN40 (1½")	0.14-1.03	2-15	5356
	0.69-2.07	10-30	737
	1.38-3.46	20-50	1163
	3.10-6.70	45-100	1303
DN50 (2")	0.14-0.69	2-20	5357
	0.69-4.14	10-60	3135
	1.38-6.70	20-100	760
	6.12-10.34	90-150	1904

## CE MARKING

The Bailey B valve has been certified to the requirements of the PED (Category II). Valve sizes below 32mm (1¼ inch), do not require, and hence, cannot be CE marked.

## PARTS

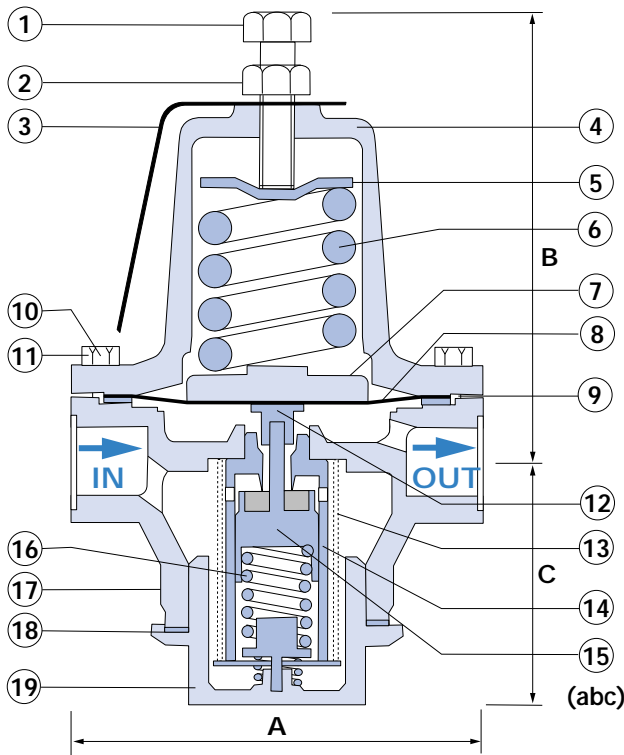

ITEM	PART	MATERIAL
1	Adjusting Screw	St. Steel
2	Lock Nut	St. Steel
3	Name Plate	Aluminium
4	Spring Chamber	Bronze
5	Spring Button	Brass
6	Pressure Spring	St. Steel
7	Pressure Plate	Brass
8*	Diaphragm	Bronze
9	Gasket	Teflon
10	Screw (Top)	St. Steel
11	Nut (Bottom)	St. Steel
12	Pusher Post Button	Brass
13*	Screen	Monel
14*	Cylinder	Brass
15	Piston Sub Assembly:-	
15a*	Pusher Rod	Brass
15b*	Seat Disc	Teflon
15c*	Piston	Brass
16*	Piston Spring	St. Steel
17	Body	Bronze
18*	Gasket	Teflon
19	Bottom Plug	Bronze

## DIMENSIONS

SIZE	DIMENSIONS			SHIP Wt (Kg)
	A	B	C	
DN15 1/2"	107	114	54	3.6
DN20 3/4"	130	117	54	4.5
DN25 1"	149	137	54	7.3
DN32 1 1/4"	171	156	67	9.1
DN40 1 1/2"	171	156	67	9.1
DN50 2"	235	216	89	17

\*Repair pack; available from Safety Systems UK Ltd.

Recommended inspection every 12 months

## FIGURE NUMBERING



SIZE	SPRING Bar (Psi)				
1 = 15mm (1/2")	1 = 0.14-2.07 (2-30)	2 = 0.69-3.45 (10-50)	3 = 2.07-8.62 (30-125)	4 = 3.45-10.34 (50-150)	-
2 = 20mm (3/4")	1 = 0.14-1.38 (2-20)	2 = 0.69-2.41 (10-35)	3 = 2.07-5.17 (30-75)	4 = 3.45-7.60 (50-110)	5 = 7.20-10.34 (105-150)
3 = 25mm (1")	1 = 0.14-1.38 (2-20)	2 = 0.69-3.10 (10-45)	3 = 1.38-4.14 (20-60)	4 = 3.79-6.90 (55-100)	5 = 6.21-10.34 (90-150)
4 = 32mm (1 1/4")	1 = 0.14-1.03 (2-15)	2 = 0.69-2.07 (10-30)	3 = 1.38-4.14 (20-60)	4 = 3.79-6.90 (55-100)	5 = 6.21-10.34 (90-150)
5 = 40mm (1 1/2")	1 = 0.14-1.03 (2-15)	2 = 0.69-2.07 (10-30)	3 = 1.38-3.45 (20-50)	4 = 3.10-6.90 (45-100)	5 = 6.21-10.34 (90-150)
5 = 50mm (2")	1 = 0.14-0.69 (2-10)	2 = 0.69-4.14 (10-60)	3 = 1.38-6.90 (20-100)	4 = 6.12-10.34 (90-150)	-

# C10 Pressure Reducing Valve

The C10 balanced pressure reducing valve range is designed for use on water/air (gas) applications and for installations which have varying inlet pressures and capacities. It is particularly suitable where positive shut-off is required under 'no flow' conditions and where compact size and economy are essential.

## OPERATION

The C10 pressure regulator is operated by a spring loaded piston and has a balanced main valve which ensures that the outlet dead-end pressure is unaffected by changes of inlet pressure.

The valve is opened by the load on the adjusting spring and closed by reduced pressure on the underside of the diaphragm. Under normal working conditions, the balance of these two forces gives the degree of valve opening for the required reduced pressure.

## FEATURES AND BENEFITS

- Cast bronze body and stainless steel seat for extended life.
- Soft disc for positive shut-off.
- Integral strainer to maximise operability and increase reliability.
- Fully balanced piston - allows a constant outlet pressure to be maintained, irrespective of varying inlet pressure.
- Simple design - enables the valve to be easily maintained and serviced without removal from the line, using only an adjustable spanner and screwdriver.
- Self actuation/regulation - requires no external power source.
- Single adjustable spring - only one spring covers the entire outlet pressure range.

## CE MARKING

For liquid applications the C10 is in accordance with the PED and does not require to be CE marked.

The C10 is not available for use on CE certified air duties.

## TECHNICAL SPECIFICATION

<b>Size</b>	15, 20, 25, 32, 40, 50 mm (1/2, 3/4, 1, 1 1/4, 1 1/2, 2 inch)
<b>Connection</b>	Screwed BSP parallel female
<b>Material</b>	Bronze.
<b>Temperature Range</b>	-18 to 82°C
<b>Maximum Inlet Pressure</b>	27 Barg
<b>Maximum Outlet Pressure*</b>	4.8 Barg
<b>Minimum Outlet Pressure*</b>	0.7 Barg

Outlet pressure should not be less than 10% of the inlet pressure.

\* Setting including rise at dead end (see pages 56, 73 and 75).

## SPRING SELECTION

DEAD END PRESSURE SETTING RANGE (Barg)	DEAD END PRESSURE SETTING RANGE (Psig)	COLOUR CODE
0.7 to 4.8	10 to 70	Only 1 Spring

## PARTS

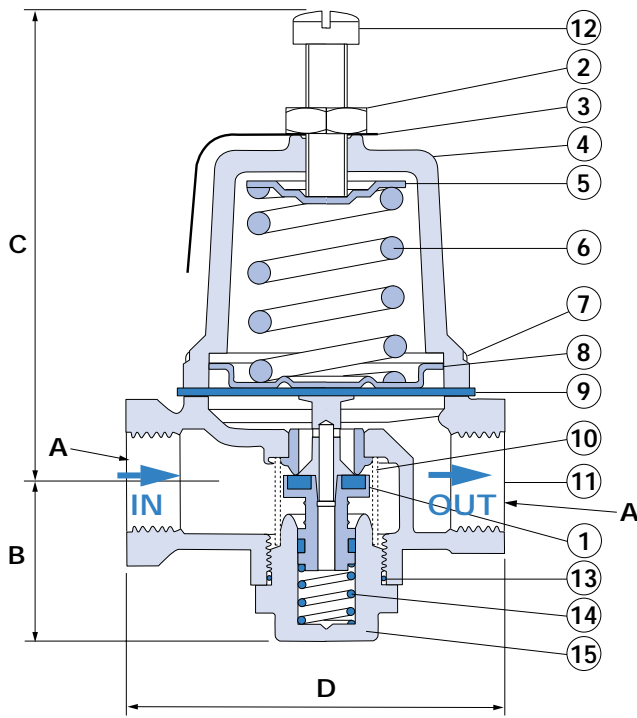

ITEM	PART	MATERIAL
1*	Piston Subassembly including: - Pusher Post - Seat Disc - Piston - 'O'-Ring	Brass EPDM Brass EPDM
2	Nut	St. St.
3	Name Plate	Aluminium
4	Spring Chamber	Iron
5	Spring Plate	Steel/Iron
6	Spring	Steel
7	Screw	Brass/St. St.
8	Pressure Plate	Steel/Iron
9*	Diaphragm	EPDM
10*	Strainer	St. St.
11	Body Subassembly including: - Body - Seat Ring	Bronze St. St.
12	Adjusting Screw	Brass
13*	'O'-Ring	EDPM
14	Piston Spring	St. St.
15	Bottom Plug	Brass

\*Repair pack; available from Safety Systems UK Ltd.

Recommended inspection every 12 months

## DIMENSIONS

SIZE	DN15	DN20	DN25	DN32	DN40	DN50
<b>A BSP</b>	1/2"	3/4"	1"	1 1/4"	1 1/2"	2"
<b>B</b>	33.40	35.50	40.40	50.60	55.70	66.50
<b>C</b>	98.20	104.80	112.70	191.00	224.70	276.00
<b>D</b>	77.00	84.20	98.00	119.10	144.50	171.50
<b>Kg</b>	0.80	1.00	1.30	3.30	5.90	9.40

All dimensions in mm.

# Class F Hose Pressure Regulator

The Class F Hose Pressure Regulator combines the features of a fire hydrant valve and a direct acting water pressure regulator, to give a single unit which protects the fire crew from excess pressure in the fire hose which could cause difficulties in handling the hose. High pressure fire systems are to be found in high rise buildings, oil, gas and chemical facilities.

## OPERATION

The Class F hose pressure regulator incorporates a spring loaded "balanced" pressure reducing valve combined with a hydrant stop valve. The stop valve element is operated in exactly the same way as a conventional hydrant stop valve (clockwise rotation to close, anti-clockwise rotation to open).

The reducing valve element is opened by the load applied to the pressure adjusting spring and closed by the reduced pressure acting upon the underside of the diaphragm. Under working conditions the balance of these two forces determines the degree of valve opening required to maintain a steady outlet pressure.

Accurate pressure control is achieved by a venturi section in the outlet flow area, which ensures that there is a minimal rise in outlet pressure between the fully open and fully closed positions.

Under conditions of varying flow rates, the close control of the Class F ensures a uniform fire fighting pressure is maintained at any hydrant in a fire protection system.

## APPLICATIONS

The Class F hose pressure regulator is suitable for:

- Fire mains systems in high rise buildings.
- High pressure systems on oil rig platforms and in oil refineries and chemical plants.
- Hand held hoses and fixed monitors, where individual pressure requirements vary.
- Applications with high pressure drops caused by the length of water mains.
- Applications with low pressure condition produced by pump characteristics.
- Floating production, storage and off-loading (FPSO) vessels.

## TECHNICAL SPECIFICATION

**Size** Valve size is always 1½"

### Connections

<b>Inlet</b>	Standard	Flanged 1½"
	Options	Flanged 2, 2½, 3"
	Available as	ANSI 150/300
<b>Outlet</b>	Standard	2½" BS336 Instantaneous female coupling.
	Options	Screwed 2½" BSP male. To suit internationally recommended adaptors.

### Materials

The standard valve construction is bronze with aluminium bronze trim, which is used for both fresh water and sea water.

This is also available in Titanium and AB2.

Our Technical Department will be pleased to advise on other required materials.

**Inlet Pressure Range** 4.8 to 20.7 Barg

**Outlet Pressure Range\*** 4.1 to 8.3 Barg

\* Setting including rise at dead end of 0.7 Barg (see page 56).

## FEATURES AND BENEFITS

- Designed to meet the needs of modern fire protection technology.
- Maintains a uniform fire fighting pressure at every hydrant in a fire protection system, irrespective of location.
- Accurate pressure control is maintained despite varying flow levels and inlet pressures.
- Greatly reduces installation costs by completely eliminating expensive relief piping systems.
- Individual floor level pressure requirements met by quick and easy in-situ regulator adjustment.
- Sea-water resistant trim incorporated as standard.
- Available in a wide variety of material options, to suit particular applications.

## CE MARKING

The Class F is not required to be PED certified on water applications, hence cannot be CE marked.

## PARTS

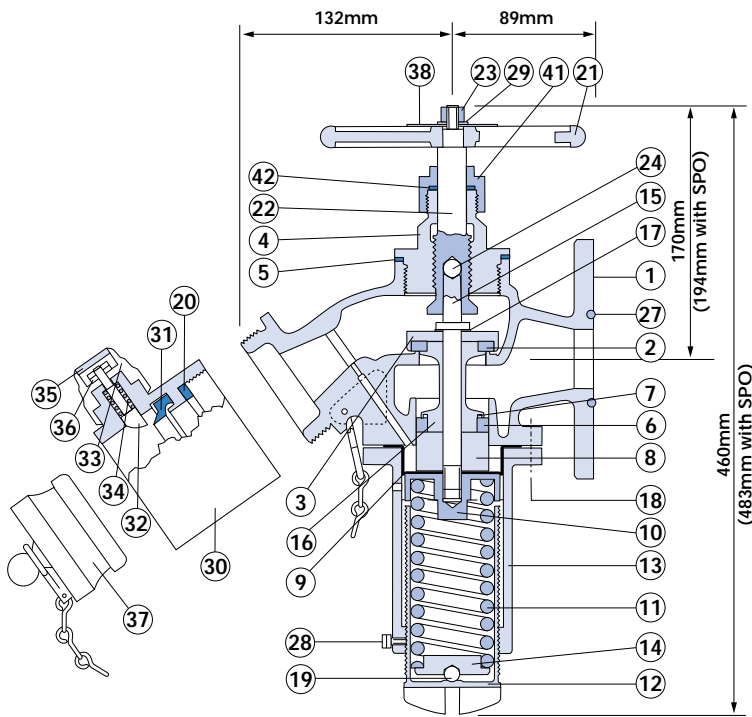

Weight approx. 15kg

## OPTIONAL 'SPO' DEVICE

### Class F with set pressure override device

An optional feature of the valve is a set pressure override device (or SPO) which, when actuated, allows full opening of the valve without regulating the downstream pressure, thereby bringing it very close to the available inlet pressure.

The SPO can be used for manifolding applications where the valve has to supply a combination of units e.g. water cannons, hand held hoses or foam making equipment.

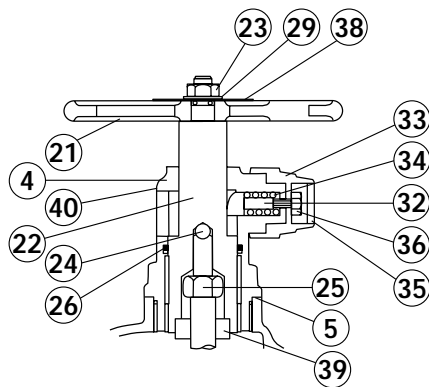

## SPRING SELECTION

DEAD END PRESSURE SETTING RANGE (Barg)	DEAD END PRESSURE SETTING RANGE (Psig)	COLOUR CODE
4.1 to 5.5	60 to 80	Brown
5.5 to 8.3	80 to 120	Blue

ITEM	PART	MATERIAL
1	Body	Bronze
2*	Valve Disc	Nitrile
3	Disc Holder	Bronze
4	Bonnet	Bronze
5*	Bonnet Joint	NAF
6*	High Pressure Seal	Rubber
7	H.P. Seal Ring	Al. Bronze
8	Distance Piece	Al. Bronze
9*	Diaphragm	Nitrile
10	Piston	Bronze
11	Spring	Plt. Steel
12	Adjusting Screw	Bronze
13	Spring Chamber	Bronze
14	Adjusting Screw Plate	Al. Bronze
15	Valve Stem	Al. Bronze
16	Valve Stem Sleeve	Al. Bronze
17*	Valve Stem Joint	NAF
18	Set Screws	St. St.
19*	Adjusting Screw Ball	Phosphor Bronze
20	Washer	Rubber
21	Handwheel	Bronze
22	Handwheel Stem	Bronze
23	Handwheel Nut	Brass
24*	Handwheel Stem Ball	Phosphor Bronze
25	Valve Stem Nut	Brass
26	Handwheel Stem 'O' Ring	Rubber
27	Body 'O' Ring	Nitrile
28	Lock Screw	St. St.
29	Handwheel Washer	Brass
30	Adaptor Body	Bronze
31*	Coupling Washer	Neoprene
32*	Coupling Bolt	Bronze
33	Quick Release Cap	Bronze
34*	Coupling Spring	Phosphor Bronze
35	Screwed Cap	Brass
36	Philidas Nut	Bronze
37	Cap and Chain	Bronze
38	Nameplate	Aluminium
39	Retaining Nut	Bronze
40	Position Indicator	Aluminium
41	Gland	Bronze
42*	Gland 'O' Ring	Nitrile

\*Repair pack; available from Safety Systems UK Ltd.

Recommended inspection every 12 months

## Installation

- 1) Mount the valve with the spring centre line vertical and with the adjusting screw uppermost.
- 2) Ensure the valve and pipework is adequately supported and that the pipe does not impose strain onto the valve.
- 3) Provide adequate headroom or adjustment and space underneath to remove the bottom cover or plug, to give access for dismantling.
- 4) It is recommended to fit pressure gauges downstream of the valve.
- 5) Isolating valves and line strainers are advisable.
- 6) The downstream (outlet) system should be protected by a correctly sized safety relief valve, set at a pressure not less than 1 barg or 15% (whichever is the greater) above the dead end setting of the regulator. See page 56 for definitions.
- 7) Flush the pipework to ensure that it is clear of dirt and debris.
- 8) For valves on air, gas and steam. The outlet piping should be expanded to accommodate the increased volume.
- 9) Ensure correct orientation of the valve, with respect to the direction of flow. Each valve is marked with a flow direction arrow.
- 10) Ensure that the correct spring is fitted for the required downstream (outlet) pressure, including the 'rise at dead end' (see page 56).

## Setting

All direct acting regulating valves should be set against a 'Dead end', allowing for a 'rise at dead end'. For definitions of these terms please refer to Page 78.

- 1) Remove all the load from the spring by unscrewing the adjusting screw (see item 12 on individual valve drawings).
- 2) Provide a downstream (outlet) 'Dead end' complete with pressure gauge, by closing a suitable isolating valve.
- 3) Admit upstream (inlet) pressure.
- 4) Commence adding load to the spring by screwing the adjusting screw (item 12). Stop when the required downstream (outlet) dead end setting pressure has been achieved.
- 5) Open the downstream isolating valve slowly to allow flow through the valve. On steam applications it is important that the down stream system is allowed to clear any condensate and to warm through gradually.
- 6) If necessary, reset the pressure by turning the adjusting screw and then checking the new dead end setting.

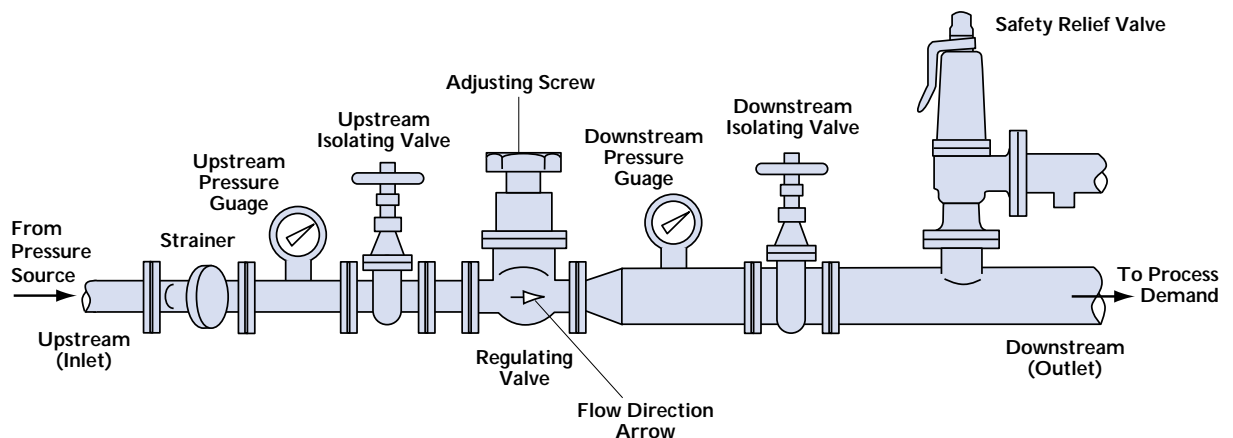



## RISE AT DEAD END

This is the amount of downstream pressure rise which occurs between the valve being fully open and closed.

All direct acting, spring loaded pressure reducing valves use two forces which open and close the valve and seat, thus regulating the flow through the valve.

- 1) The '**spring force**' which tends to open the valve.
- 2) The '**diaphragm force**' is created by the pressure in the outlet, acting on the underside of the diaphragm, opposing the spring force. This force tends to close the valve. When the valve is flowing at the correct pressure, the spring will have pushed the valve the correct distance away from the seat, allowing flow through the valve.

Once there is no demand from the system, the outlet pipe work will effectively be closed, i.e. the flow through the valve will come up against a dead end (nowhere to go). Under this condition the pressure will rise in the outlet, which in turn will increase the diaphragm force which opposes the spring force. This will tend to close the valve. When the diaphragm force is greater than the spring force, the valve will be fully closed.

The amount of rise in the outlet from the flowing pressure to the fully closed pressure is thus called "Rise at dead end".

## DEAD END SETTING

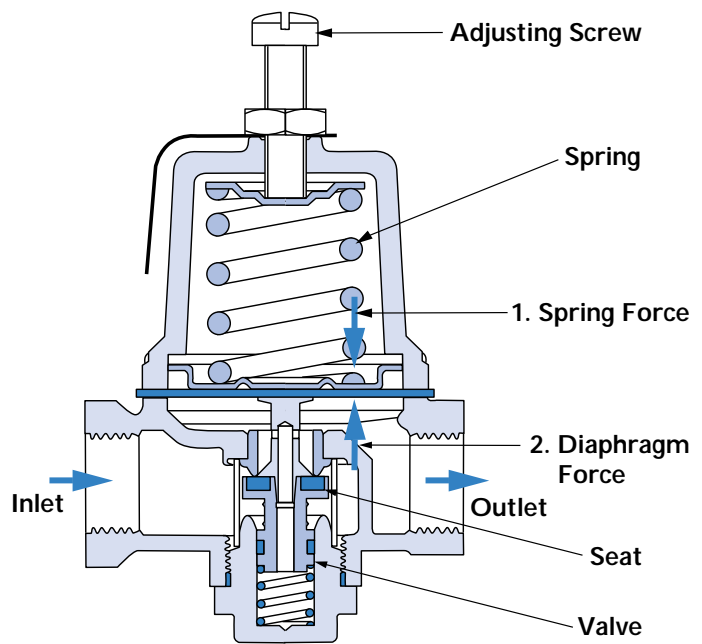

When commissioning the system and setting the valve, it is recommended practice to close off the outlet piping, i.e. dead end. It is important therefore to set the valve under this condition at the dead end pressure (flowing pressure plus the rise at dead end).

**It is also important that when selecting the appropriate spring, the dead end pressure is used and not the flowing pressure.**

All sizing charts are based on the valve being fully open with a standard rise at dead end. However, alternative figures can be used, that reduce or increase the flow rate, dependent on the allowable rise. Please refer to the sizing examples.

# 1001S Sightglass

## DESIGN

- Virtually resistant to chemical attack.
- Glass conforms to BS2598/1980.
- Unrestricted full bore flow.
- All-round visibility.
- Stainless steel (316L) carrier and flanges.
- One-piece continuous PTFE end seals as standard. Viton and Neoprene end seals can be fitted on request.
- Can be supplied assembled as shown, or as a kit of finished parts with or without glass.



## APPLICATIONS

The only material in contact with the fluid is the boro-silicate glass and seals. The Type 1001S Sightglass can therefore handle almost all fluids and has applications in the chemical and pharmaceutical industries in particular.

## CE MARKING

In accordance with the PED the 1001 sight glass does not require CE marking, but will be issued with a statement of conformance.

## TECHNICAL DATA

There are two pressure options, 1001S low pressure and 1001SH high pressure.

MAXIMUM WORKING PRESSURES							
Size		1"	1½"	2"	3"	4"	6"
Max. Working Pressure 1001S	Bar	4.0	4.0	4.0	3.0	2.0	2.0
with Corwrap shatter protection	Bar	4.0	4.0	4.0	3.0	2.0	2.0
Max. Working Pressure 1001SH	Bar	9.0	9.0	9.0	7.0	7.0	8.25
with Corwrap shatter protection	Bar	6.0	6.0	6.0	4.5	4.5	4.5

WORKING TEMPERATURES (Dependent on end seals)		
End Seal	Minimum °C	Maximum °C
PTFE	-50°C	200°C
Viton	-30°C	160°C
Neoprene	-40°C	120°C

DIMENSIONS (1001S and 1001SH)							
Size		1"	1½"	2"	3"	4"	6"
Overall length*	mm	185	185	185	185	192	205

\* With standard 150mm glass. Longer glass can be supplied to special order.

## END CONNECTIONS

Available flanged to BS10 Table E, BS 4504 PN 10, DIN PN10 or ANSI 150.

## SIGHT GLASS

The Bailey 1001S Sight Glass is used widely in the chemical, pharmaceutical, food, drink and allied industries, where visual monitoring is essential. The flanges are stainless steel and the glass is made from Borosilicate. Borosilicate glass has excellent transparent properties and is resistant to almost all substances except hydrofluoric acid, phosphoric acid and hot strong caustic solutions. The glass is suitable for temperatures up to 200°C and it will tolerate a degree of thermal shock, however rapid changes in temperature should be avoided as it will increase the stress within the glass.

## CORWRAP SHATTER PROTECTION

When dealing with glass the inevitable can happen, the glass can break. However it may happen, by thermal shock or accidental impact, the result will be the same. Broken glass and leaking process fluids can cause further accidents. Whether the fluid is a chemical or a drinks concentrate the clean up operation can be huge. Bailey can offer additional protection in such circumstances by the addition of a single layer of polyester-impregnated glass fibre cloth called CORWRAP, applied to the external surface of the glass. Whilst CORWRAP does have very good resistant properties, it does not have the excellent resistance to corrosion as the glass.

If a glass does break, CORWRAP firstly contains the broken glass reducing any resultant danger, and secondly it will for a limited period contain the process fluid, often for a time sufficient to safely shut down the process and drain the fluid to a safe level, thus allowing a new glass to be installed.

Being suitable for operating temperatures up to 150°C CORWRAP has a grey textured finish and it is translucent, hence retains a degree of visual monitoring of the process fluid.

# Capacity Charts/ Sizing

## AIR CAPACITY CHART (l/s) @ 0.3 Barg or 10% overpressure\* and 15°C

Set Pressure (Barg)	Valve Type 707 BS EN ISO 4126 Pt 1 (BS6759 Pt 1:2:3)						Valve Type 716 (BS6759 Pt2)					
	DN15	DN20	DN25	DN32	DN40	DN50	DN15	DN20	DN25	DN32	DN40	DN50
0.35	3.93	11.4	15.0	24.7	38.7	60.6	18.3	52.6	69.6	111	180	279
1.0	8.28	23.9	31.6	52.0	81.5	128	31.2	89.9	119	189	308	476
2.0	13.6	39.1	51.7	85.0	133	209	48.8	140	186	295	481	744
3.0	18.3	52.8	69.8	115	180	282	63.5	183	242	384	626	968
4.0	22.9	66.3	87.6	144	226	354	79.7	230	303	482	786	1215
5.0	27.6	79.7	105	173	272	426	95.9	276	365	580	945	1462
6.0	32.3	93.2	123	203	317	497	112	323	427	678	1105	1708
7.0	36.9	107	141	232	363	569	128	369	488	776	1265	1955
8.0	41.6	120	159	261	409	641	144	416	550	874	1424	2202
9.0	46.2	134	177	290	455	713	161	463	611	972	1584	2449
10.0	50.9	147	194	320	501	785	177	509	673	1070	1744	2696
12.0	60.2	174	230	378	593	929	209	603	796	1267	2063	3189
12.5	66.6	181	239	393	616	965	217	626	827	1316	2143	3313
14.0	69.5	201	265	437	684	1072	242	696	920	1463	2382	3683
16.0	78.9	228	301	495	776	1216	274	789	1043	1659	2701	4177
18.0	88.2	255	337	554	868	1360	306	882	1166	1855	3021	4670
20.0	97.5	282	372	612	960	1504	339	976	1289			
22.0	107	309	408	671	1051	1647	371	1069				
24.0	116	336	443	729	1143	1791	403	1162				
26.0							436		Maximum pressure per size based on 716 bronze valve. 716 C1 and SS maximum pressure 12.5 Barg.			
28.0							468					
30.0							501					
32.0							533					

\* Minimum overpressure = 0.07 Barg at set pressure less than 1.0 Barg.

### Other Gases

If you wish to use the valve on other compatible gases, the sizing details above can be used. The valve capacity will however change depending on the specific gravity of the flowing gas. Multiply the valve air capacity by  $1/\sqrt{SG}$  to give the gas capacity. SG = specific gravity (relative to air = 1).

### Useful Conversions

Nm<sup>3</sup>/h = 1/sec x 3.60

SCFM = 1/sec x 2.12

716H (ASME VIII) Air Capacity @ 10% Overpressure & 15°C		
Set Pressure	No.6 Orifice	No.7 Orifice
Barg	l/s	l/s
1	–	37
10	–	210
20	–	403
30	–	595
40	–	787
50	–	980
51	407	999
60	478	–
80	635	–
100	791	–
102	807	–

## AIR CAPACITY CHART (l/s) @ 0.3 Barg or 10% overpressure\* and 15°C

Set Pressure (Barg)	Valve Type 746# (BS6759 Pt2)							Valve Type 776 (AD MERKBLATT A2)								
	DN25	DN32	DN40	DN50	DN65	DN80	DN100	1/1R DN20	1/2R DN20	1/2M DN15	1/2M1 DN20	1/3 DN20	1/4 DN25	1/5 DN32	1/6 DN40	1/7 DN50
0.35	69.6	109	178	275	467	711	1098									
1.0	115	182	297	459	781	1188	1836	15.3	15.3	26.9	26.9	71.3	77.5	103	163	265
2.0	181	287	468	723	1231	1872	2894	24.9	24.9	40.3	40.3	107	116	153	244	397
3.0	242	384	626	968	1646	2505	3872	34	34	58.7	58.7	155	169	224	356	579
4.0	303	482	786	1215	2066	3144	4859	42.5	42.5	73.4	73.4	205	211	279	444	723
5.0	365	580	945	1462	2486	3782	5846	51.0	51.0	88.0	88.0	246	253	335	533	868
6.0	427	678	1105	1708	2906	4421	6834	59.5	59.5	103	103	287	296	391	621	1012
7.0	488	776	1265	1955	3326	5060	7821	67.9	67.9	117	117	328	338	446	710	1156
8.0	550	874	1424	2202	3746	5699	8808	76.4	76.4	132	132	369	380	502	798	1301
9.0	611	972	1584	2449	4165	6337	9795	84.9	84.9	147	147	410	422	558	887	1445
10.0	673	1070	1744	2696	4585	6976	10783	93.4	93.4	161	161	451	464	613	976	1589
12.0	796	1267	2063	3189	5425	8253	12757	110	110	190	190	533	548	725	1153	1878
12.5	827	1316	2143	3313	5635	8573	13251	115	115	198	198	553	570	752	1197	1950
14.0	920	1463	2382	3683	6265	9531	14732	128	128	220	220	614	633	836	1330	2166
16.0	1043	1659	2701	4177	7104	10808	16706	144	144	249	249	696	717	948	1507	2455
18.0	1166	1855	3021	4670	7944	12086	18681	161	161	278	278	778	801	1059	1684	2743
20.0	1289	2051	3340	5164	8784	13363	20655	178	178	307	307	860	886	1171	1862	3032
22.0	1413	2247	3659	5658	9623	14641	22630	195	195	337	337	942	970			
24.0	1536	2443	3979	6151	10463	15918	24605	212	212	366	366	1024	1054			
26.0	1659	2639	4298	6645	11303	17196		229	229	395	395	1106	1139			
28.0	1782	2835	4617	7138	12142	18473		246	246	424	424	1187	1223			
30.0	1906	3031	4936	7632	12982	19751		263	263	454	454	1269	1307			
32.0	2029	3227	5256	8126	13822	21028										
34.0	2152	3423	5575	8619	14661											
36.0	2276	3619	5894	9113												
38.0	2399	3815	6214	9607												
40.0	2522	4011	6533	10100												

\* Minimum overpressure = 0.07 Barg at set pressure less than 1.0 Barg.

# The 746 can be sized/certified to ASME VIII and AD Merkblatt A2 - contact factory for details.

## AIR CAPACITY CHART (l/s) @ 0.07\* Barg or 10% overpressure and 15°C Valve Type 616D

Valve Size	Set Pressure Barg											
	0.2*	0.35*	0.5*	0.65*	0.8	1.0	1.2	1.4	1.6	1.8	2.0	2.5
DN40	64.2	75.7	87.9	101	116	137	160	186	212	241	271	340
DN50	115	132	150	169	191	222	252	286	322	359	398	490

## SATURATED STEAM CAPACITY CHART (kg/h)

Set Pressure (Barg)	Valve Type 707 BS EN ISO 4126 pt 1 (BS6759 pt 1:2:3 @ 10% Overpressure*)						Valve Type 716 (BS6759 Pt1 @ 5% Overpressure)†					
	DN15	DN20	DN25	DN32	DN40	DN50	DN15	DN20	DN25	DN32	DN40	DN50
0.35	9.68	28.0	37.0	60.8	95.3	149	35.6	103	136	216	351	543
1.0	22.6	65.2	86.2	142	222	348	70.5	203	269	427	696	1075
2.0	35.9	104	137	225	353	553	125	359	475	755	1230	1902
3.0	47.8	138	182	300	470	737	167	480	635	1010	1645	2543
4.0	59.3	171	226	372	583	914	209	602	795	1265	2060	3185
5.0	76.6	221	292	481	753	1181	251	723	955	1519	2475	3826
6.0	89.0	257	340	559	876	1372	293	844	1115	1774	2889	4467
7.0	99.9	289	381	627	983	1540	335	965	1276	2029	3304	5108
8.0	112	324	428	705	1104	1731	377	1086	1436	2283	3719	5750
9.0	123	355	469	771	1208	1893	419	1207	1596	2538	4134	6391
10.0	135	390	515	848	1329	2082	461	1329	1756	2793	4549	7032
12.0	157	454	600	987	1548	2425	545	1571	2076	3302	5378	8315
12.5	167	482	637	1048	1642	2573	566	1632	2156	3429	5586	8636
14.0	182	524	693	1140	1787	2799	629	1831	2397	3811	6208	9598
16.0	201	606	801	1318	2066	3237	714	2056	2717	4321	7038	10880
18.0	243	702	928	1527	2393	3750	798	2298	3037	4830	7867	12163
20.0	256	739	977	1606	2518	3946	882	2540	3357			
22.0	284	822	1086	1786	2799	4386	966	2783				
24.0	308	889	1174	1931	3027	4743				Maximum pressure per size based on 716 bronze valve.		
26.0												
28.0										716 C1 and SS maximum pressure 12.5 Barg.		
30.0												

\* Minimum overpressure = 0.07 Barg at set pressure less than 0.7 Barg.

† Minimum overpressure = 0.07 Barg at set pressure less than 1.0 Barg.

### Other Temperatures

The steam tables on these pages are based on saturated steam, at the temperatures shown.

For steam systems operating at higher temperatures, the above capacities will need to be derated by using the super heat correction factor. Refer to page 63.

### Useful Conversions

lbs/h = kg/h x 2.2046

716H (ASME VIII) Steam Capacity @ 10% Overpressure		
Set Pressure	No.6 Orifice	No.7 Orifice
Barg	kg/h	kg/h
1	–	100
10	–	567
20	–	1086
30	–	1605
40	–	2124
50	–	2643
51	1098	2695
60	1289	–
80	1712	–
100	2135	–
102	2177	–

## SATURATED STEAM CAPACITY CHART (kg/h)

Set Pressure (Barg)	Valve Type 746 <sup>#</sup> (BS6759 Pt1 @ 5% Overpressure)†							Valve Type 756 (BS6759 Pt1 @ 5% Overpressure)†						Metal Seat Valve Type 766 (BS6759 Pt1 @ 10% Overpressure)*			
	DN25	DN32	DN40	DN50	DN65	DN80	DN100	DN25	DN32	DN40	DN50	DN65	DN80	DN40	DN50	DN65	DN80
0.35	124	198	322	498	847	1289	1992	161	257	419	648	1101	1676	402	716	1119	1611
1.0	269	429	698	1079	1836	2793	4317	297	472	769	1189	2022	3076	893	1587	2480	3571
2.0	457	727	1183	1830	3112	4735	7318	486	773	1258	1945	3309	5034	1485	2640	4125	5940
3.0	635	1010	1645	2543	4326	6581	10173	650	1033	1683	2601	4425	6732	2065	3673	5738	8262
4.0	795	1265	2060	3185	5417	8241	12738	813	1294	2107	3257	5541	8429	2592	4609	7201	10369
5.0	955	1519	2475	3826	6508	9901	15303	977	1554	2531	3913	6656	10127	3119	5545	8664	12475
6.0	1115	1774	2889	4467	7598	11560	17869	1141	1815	2955	4567	7772	11825	3645	6482	10127	14582
7.0	1276	2029	3304	5108	8689	13220	20433	1305	2075	3380	5225	8888	13522	4172	7418	11591	16689
8.0	1436	2283	3719	5750	9780	14880	22999	1469	2336	3804	5881	10004	15220	4699	8355	13054	18795
9.0	1596	2538	4134	6391	10871	16539	25565	1632	2596	4228	6537	11120	16917	5226	9291	14517	20902
10.0	1756	2793	4549	7032	11962	18199	28130	1796	2857	4653	7193	12235	18615	5752	10228	15980	23009
12.0	2076	3302	5378	8315	14143	21518	33260	2124	3378	5501	8505	14467	22010	6806	12100	18906	27222
12.5	2156	3429	5586	8636	14689	22348	34543	2206	3508	5713	8833	15024	22859	7069	12569	19638	28276
14.0	2397	3811	6208	9598	16325	24838	38391	2451	3898	6350	9817	16699	25405	7859	13974	21832	31436
16.0	2717	4321	7038	10880	18587	28157	43522	2779	4419	7198	11129	18930	28800	8912	15847	24759	35649
18.0	3037	4830	7867	12163	20689	31476	48652	3107	4940	8047	12441	21162	32196	9965	17720	27685	39863
20.0	3357	5339	8697	13446	22871	34795	53783	3434	5461	8896	13753	23393	35591	11019	19593	30612	44076
22.0	3678	5849	9526	14728	25052	38115	58913	3762	5982	9744	15065	25625	38986	12072	21466	33538	48289
24.0	3998	6358	10356	16011	27234	41434	64044	4089	6503	10593	16377	27857	42381	13126	23338	36464	52503
26.0	4318	6868	11186	17293	29416	44753											
28.0	4638	7377	12015	18576	31598	48073											
30.0	4959	7886	12845	19859	33779	51392											
32.0	5279	8396	13675	21142	35961	54711											
34.0	5599	8905	14504	22424	38143												
36.0	5919	9414	15334	23707													
38.0	6240	9924	16164	24990													
40.0	6560	10433	16993	26272													

\* Minimum overpressure = 0.07 Barg at set pressure less than 0.7 Barg.

† Minimum overpressure = 0.07 Barg at set pressure less than 1.0 Barg.

# The 746 can be sized/certified to ASME VIII and AD Merkblatt A2 - contact factory for details.

### FSH - SUPERHEAT STEAM CORRECTION TABLE

Set Pressure (Barg)	Saturated Steam Temp. °C	Total Steam Temperature in Degrees Centigrade					
		150	200	260	310	370	430
1	120	1.00	0.98	0.93	0.88	0.84	0.80
4	150	1.00	0.99	0.93	0.88	0.84	0.81
7	170	1.00	0.99	0.94	0.89	0.84	0.81
10	361	1.00	0.99	0.94	0.89	0.85	0.81
14	180	1.00	0.99	0.95	0.89	0.85	0.81
18	210	-	1.00	0.95	0.90	0.85	0.81
24	220	-	1.00	0.96	0.90	0.86	0.82
34	240	-	1.00	0.96	0.92	0.86	0.82
41	250	-	1.00	0.97	0.92	0.87	0.82



## WATER CAPACITY CHART (l/min) @ 10% overpressure\* @ 20°C

Set Pressure (Barg)	Valve Type 707 (BS6759 Pt3)						Valve Type 716 (BS6759 Pt3)					
	DN15	DN20	DN25	DN32	DN40	DN50	DN15	DN20	DN25	DN32	DN40	DN50
0.35	10.3	29.8	39.4	64.8	102	159	27.6	79.4	105	167	272	420
1.0	16.7	48.3	63.8	105	164	258	44.6	129	170	270	440	680
2.0	23.6	68.3	90.2	148	233	364	63.1	182	240	382	622	962
3.0	28.9	83.6	110	182	285	446	77.3	223	294	468	762	1178
4.0	33.4	96.5	128	210	329	515	89.3	257	340	540	880	1361
5.0	37.4	108	143	235	368	576	99.8	287	380	604	984	1521
6.0	40.9	118	156	257	403	631	109	315	416	662	1078	1667
7.0	44.2	128	169	278	435	682	118	340	449	715	1164	1800
8.0	47.3	137	180	297	465	729	126	364	481	764	1245	1924
9.0	50.1	145	191	315	493	773	134	386	510	811	1320	2041
10.0	52.8	153	202	332	520	815	141	406	537	854	1392	2152
12.0	57.9	167	221	363	570	893	155	445	589	936	1525	2357
12.5	59.1	171	226	371	581	911	158	454	601	955	1556	2406
14.0	62.5	181	239	392	615	964	167	481	636	1011	1647	2546
16.0	66.8	193	255	420	658	1031	179	514	680	1081	1760	2722
18.0	70.9	205	271	445	698	1093	189	545	721	1146	1867	2887
20.0	74.7	216	285	469	735	1152	200	575	760			
22.0	78.4	226	299	492	771	1208	209	603				
24.0	81.9	236	312	514	806	1262	219	639				
26.0							227					
28.0							236					
30.0							244					
32.0							252					
34.0												
36.0												
38.0												
40.0												

\* Minimum overpressure = 0.07 Barg at set pressure less than 0.7 Barg.

### Useful Conversions

l/gpm = 1/min x 0.22  
 m<sup>3</sup>/min = 1/min x 0.001

### Other Liquids

If you wish to use the valve on other compatible liquids, the sizing details above can be used. The valve capacity will however change depending on the specific gravity of the flowing liquid. Multiply the valve water capacity by  $1/\sqrt{SG}$  to give the liquid capacity.  
 SG = specific gravity (relative to water = 1).

Maximum pressure per size based on 716 bronze valve.  
 716 C1 and SS maximum pressure 12.5 Barg.

## WATER CAPACITY CHART (l/min) @ 10% overpressure\* @ 20°C

Set Pressure (Barg)	Valve Type 746# (BS6759 Pt3)							Valve Type 480/490 Series (BS6759 part 3)				
	DN25	DN32	DN40	DN50	DN65	DN80	DN100	DN20	DN25	DN40	DN50	DN80
0.35	105	167	272	420	715	1088						
1.0	170	270	440	680	1157	1761	2722	27.90	49.63	112	198	446
2.0	240	382	622	962	1637	2490	3849	34.17	60.78	137	243	547
3.0	294	468	762	1178	2005	3050	4714	39.46	70.19	158	281	631
4.0	340	540	880	1361	2315	3522	5443	55.80	99.27	223	397	893
5.0	380	604	984	1521	2588	3937	6086	62.39	111	250	444	998
6.0	416	662	1078	1667	2835	4313	6666	48.34	122	273	486	1093
7.0	449	715	1164	1800	3062	4659	7210	73.82	131	295	525	1181
8.0	481	764	1245	1924	3273	4980	7698	78.91	140	316	561	1263
9.0	510	811	1320	2041	3472	5282	8165	83.70	149	334	595	1339
10.0	537	854	1392	2152	3660	5568	8606	88.23	157	353	628	1412
12.0	589	936	1525	2357	4009	6099	9428	96.65	172	387	687	—
12.5	601	955	1556	2406	4092	6225	9622	98.64	176	395	702	—
14.0	636	1011	1647	2546	4330	6588	10183	104	186	418	742	—
16.0	680	1081	1760	2722	4629	7043	10886	112	199	446	794	—
18.0	721	1146	1867	2887	4910	7470	11547	118	211	473	842	—
20.0	760	1208	1968	3043	5176	7874	12171	125	222	499	887	—
22.0	797	1267	2064	3191	5428	8259	12765	131	233	523	931	—
24.0	832	1324	2156	3333	5670	8626	13332	137	243	547	972	—
26.0	866	1378	2244	3469	5901	8978						
28.0	899	1430	2329	3600	6124	9317						
30.0	931	1480	2410	3727	6339	9644						
32.0	961	1528	2490	3849	6547	9960						
34.0	991	1575	2566	3967	6748							
36.0	1019	1621	2641	4082								
38.0	1047	1666	2713	4194								
40.0	1074	1709	2783	4303								

\* Minimum overpressure = 0.07 Barg at set pressure less than 0.7 Barg.

# The 746 can be sized/certified to ASME VIII and AD Merkblatt A2 - contact factory for details.

### Useful Conversions

USgpm = l/min x 0.26

### 716H (ASME VIII) Water Capacity @ 10% Overpressure & 20°C

Set Pressure	No.6 Orifice	No.7 Orifice
Barg	l/m	l/m
1	—	49
10	—	155
20	—	219
30	—	269
40	—	310
50	—	347
51	193	350
60	209	—
80	241	—
100	270	—
102	272	—

## HOT WATER CAPACITY CHART (kW) FOR A PRESSURISED (un-vented) SYSTEM

Set Pressure (Barg)	Valve Type 707 (BS6759 Pt1 @ 10% Overpressure)*						Valve Type 716 (BS6759 Pt1 @ 5% Overpressure)†					
	DN15	DN20	DN25	DN32	DN40	DN50	DN15	DN20	DN25	DN32	DN40	DN50
0.35	6.88	19.9	26.3	43.2	67.7	106	54.5	157	208	330	538	832
1.0	14.0	40.5	53.5	88.0	138	216	61.9	178	236	374	611	944
2.0	22.9	66.3	87.5	144	226	354	78.2	225	298	473	771	1192
3.0	30.9	89.4	118	194	304	477	105	301	398	633	1031	1594
4.0	38.8	112	148	244	382	599	131	377	498	792	1291	1996
5.0	46.7	135	178	293	460	720	157	453	599	952	1551	2398
6.0	54.6	158	208	343	537	842	184	529	699	1112	1811	2799
7.0	62.5	181	239	392	615	964	210	605	799	1271	2071	3201
8.0	70.4	203	269	442	693	1085	236	681	900	1431	2331	3603
9.0	78.3	226	299	491	770	1207	263	757	1000	1590	2591	4005
10.0	86.2	249	329	541	848	1329	289	833	1100	1750	2851	4407
12.0	102	294	389	640	1003	1572	342	984	1301	2069	3370	5211
12.5	106	306	404	665	1042	1633	355	1022	1351	2149	3500	5412
14.0	118	340	449	739	1158	1815	394	1136	1501	2388	3890	6015
16.0	133	386	510	838	1314	2059	447	1288	1703	2708	4410	6818
18.0	149	431	570	937	1469	2302	500	1440	1903	3027	4930	7622
20.0	165	477	630	1036	1624	2545	553	1592	2104			
22.0	181	522	690	1135	1780	2788	605	1744				
24.0	197	568	751	1234	1935	3032						
26.0												
28.0												
30.0												
32.0												
34.0												
36.0							Maximum pressure per size based on 716 bronze valve.					
38.0												
40.0							For 716 C1 and SS maximum pressure 12.5 barg.					

\* Minimum overpressure = 0.07 Barg at set pressure less than 0.7 Barg.

† Minimum overpressure = 0.07 Barg at set pressure less than 1.0 Barg.

### Note

**Pressurised (un-vented) hot water systems** have the entire discharge capacity handled solely by the valve.

**Open vented systems** take into account the discharge capacities of the vent. Hence the equivalent discharge of the valve/system is considered to be double the above chart capacities.

## HOT WATER CAPACITY CHART (kW) FOR A PRESSURISED (un-vented) SYSTEM

Set Pressure (Barg)	Valve Type 746 (BS6759 Pt1 @ 5% Overpressure)†						
	DN25	DN32	DN40	DN50	DN65	DN80	DN100
0.35	227	360	587	907	1543	2547	3628
1.0	235	374	608	941	1600	2434	3762
2.0	309	492	801	1239	2107	3206	4956
3.0	398	633	1031	1594	2711	4124	6375
4.0	498	792	1291	1996	3394	5164	7983
5.0	599	952	1551	2398	4078	6204	9590
6.0	699	1112	1811	2799	4762	7244	11198
7.0	799	1271	2071	3201	5445	8285	12805
8.0	900	1431	2331	3603	6129	9721	14413
9.0	1000	1590	2591	4005	6813	10365	16020
10.0	1100	1750	2851	4407	7496	11405	17628
12.0	1301	2069	3370	5211	8863	13485	20843
12.5	1351	2149	3500	5412	9205	14005	21647
14.0	1501	2388	3890	6015	10231	15565	24058
16.0	1703	2708	4410	6818	11598	17645	27274
18.0	1903	3027	4930	7622	12965	19725	30489
20.0	2104	3346	5450	8426	14332	21805	33704
22.0	2304	3665	5970	9230	15699	23885	36919
24.0	2505	3984	6490	10034	17067	25965	40134
26.0	2706	4304	7010	10837	18434	28045	
28.0	2907	4623	7530	11641	19801	30125	
30.0	3107	4942	8050	12445	21168	32206	
32.0	3308	5261	8569	13249	22536	34286	
34.0	3509	5580	9089	14053	23903		
36.0	3710	5900	9609	14856			
38.0	3910	6219	10129	15660			
40.0	4111	6538	10649	16464			

† Minimum overpressure = 0.07 Barg at set pressure less than 1.0 Barg.

## G4 DRY SATURATED STEAM CAPACITY - Kg/h See page 41 for a sizing example

Inlet Pressure Barg	Outlet Pressure Barg												
		R15mm	15mm	20mm	25mm	32mm	40mm	50mm	65mm	80mm	100mm	125mm	150mm
<b>0.70</b>	0.35	14.4	42.5	86.7	143	215	310	534	NA	NA	NA	NA	NA
	0.07*	14.4	42.5	86.7	143	215	310	534	NA	NA	NA	NA	NA
<b>1.00</b>	0.65	15.3	46.7	95.3	157	239	346	594	NA	NA	NA	NA	NA
	0.55	16.3	49.5	101	166	254	367	630	NA	NA	NA	NA	NA
	0.32*	16.3	49.5	101	166	254	367	630	1072	1337	2397	NA	NA
	0.07*	16.3	49.5	101	166	254	367	630	1072	1337	2397	NA	NA
<b>2.00</b>	1.65	19.2	58.7	120	197	300	434	747	NA	NA	NA	NA	NA
	1.30	22.8	69.5	141	233	356	514	884	1418	1769	3171	4590	6538
	1.10	24.8	75.5	154	254	386	559	960	1540	1920	3442	4981	7095
	0.35	24.8	75.5	154	254	386	559	960	1540	1920	3442	4981	7095
	0.07*	24.8	75.5	154	254	386	559	960	1540	1920	3442	NA	NA
<b>5.00</b>	4.30	35.4	108	220	363	553	799	1374	NA	NA	NA	NA	NA
	4.00	39.9	121	248	408	623	900	1547	2347	2388	2978	5338	7727
	2.75	51.8	158	322	530	808	1168	2007	3219	4015	7196	10415	14834
	0.35	51.8	158	322	530	808	1168	2007	3219	4015	7196	10415	14834
	0.07*	51.8	158	322	530	808	1168	2007	3219	4015	7196	NA	NA
<b>10.00</b>	9.00	56.7	172	352	580	884	1279	2198	3024	3771	6759	9783	13934
	5.50	95.4	291	593	977	1489	2152	3699	5932	7398	13260	19193	27335
	1.20	95.4	291	593	977	1489	2152	3699	5932	7398	13260	19193	27335
	0.35	95.4	291	593	977	1489	2152	3699	5932	7398	13260	NA	NA
<b>15.00</b>	14.00	67.9	207	422	695	1059	1531	2633	3216	4011	7190	NA	NA
	12.00	108	330	673	1109	1690	2443	4199	6629	8267	14819	21448	30548
	8.25	139	423	862	1420	2164	3128	5377	8624	10755	19277	27901	39739
	2.90	139	423	862	1420	2164	3128	5377	8624	10755	19277	27901	39739
	0.80*	139	423	862	1420	2164	3128	5377	8624	10755	19277	NA	NA
<b>20.00</b>	19.00	78.3	238	487	802	1222	1767	3037	3360	4190	7511	NA	NA
	12.00	177	539	1101	1814	2764	3995	6868	11014	13736	24621	35636	50755
	11.00	181	552	1126	1855	2827	4086	7024	11265	14048	25180	36445	51906
	4.60	181	552	1126	1855	2827	4086	7024	11265	14048	25180	36445	51906
	3.10	181	552	1126	1855	2827	4086	7024	11265	14048	25180	NA	NA
	1.28	181	552	1126	1855	2827	4086	7024	NA	NA	NA	NA	NA
<b>25.00</b>	20.70	164	500	1020	1680	2560	3700	6359	9717	12118	21720	NA	NA
	13.75	220	684	1395	2297	3500	5059	8696	13946	17392	31174	45120	64261
	12.00	220	684	1395	2297	3500	5059	8696	13946	17392	31174	45120	64261
	6.30	220	684	1395	2297	3500	5059	8696	13946	17392	31174	45120	64261
	2.80	220	684	1395	2297	3500	5059	8696	NA	NA	NA	NA	NA
<b>30.00</b>	20.70	243	743	1516	2497	3805	5500	9454	15162	18908	33891	NA	NA
	16.50	268	817	1667	2746	4184	6047	10395	16671	20789	37264	NA	NA
	12.00	268	817	1667	2746	4184	6047	10395	16671	20789	37264	53934	76816
	8.00	268	817	1667	2746	4184	6047	10395	16671	20789	37264	53934	76816
	6.90	268	817	1667	2746	4184	6047	10395	16671	20789	37264	NA	NA
	4.60	268	817	1667	2746	4184	6047	10395	NA	NA	NA	NA	NA
<b>35.00</b>	20.70	305	930	1898	3126	4763	6884	11834	18979	23668	42425	NA	NA
	19.25	309	943	1923	3168	4827	6977	11993	19234	23986	42993	NA	NA
	12.00	309	943	1923	3168	4827	6977	11993	19234	23986	42993	62227	88627
	9.60	309	943	1923	3168	4827	6977	11993	19234	23986	42993	62227	88627
	7.50	309	943	1923	3168	4827	6977	11993	19234	23986	42993	NA	NA
	6.20	309	943	1923	3168	4827	6977	11993	NA	NA	NA	NA	NA
<b>40.00</b>	20.70	353	1074	2195	3615	5508	7961	13684	21945	27367	49055	NA	NA
	12.00	353	1074	2195	3615	5508	7961	13684	21945	27367	49055	71000	101121
	10.30	353	1074	2195	3615	5508	7961	13684	21945	27367	49055	71000	101121
	8.07	353	1074	2195	3615	5508	7961	13684	21945	27367	49055	NA	NA
	6.20	353	1074	2195	3615	5508	7961	13684	NA	NA	NA	NA	NA
<b>42.00</b>	20.70	369	1125	2295	3780	5760	8325	14310	22950	28619	51299	NA	NA
	12.00	369	1125	2295	3780	5760	8325	14310	22950	28619	51299	74249	105748
	10.30	369	1125	2295	3780	5760	8325	14310	22950	28619	51299	74249	105748
	8.30	369	1125	2295	3780	5760	8325	14310	22950	28619	51299	NA	NA
	6.20	369	1125	2295	3780	5760	8325	14310	NA	NA	NA	NA	NA

**Useful Conversions**  
lbs/h = kg/h x 2.2046

\* Low pressure top required for outlet pressures below 0.35 Barg

1. The Max. & Min. outlet pressure for a given inlet pressure and valve size, can be determined from the above table. E.g. a 100mm valve with an inlet pressure of 40 Barg has a maximum available outlet pressure of 20.7 Barg and a minimum of 8.07 Barg.
2. To ensure the above flows, it is critical the correct size of outlet pipe is used. See page 70.
3. For super heated steam the above capacities need to be derated. See page 40

## G4 AIR CAPACITY - l/s @ 15°C

Inlet Pressure Barg	Outlet Pressure Barg													
		R15mm	15mm	20mm	25mm	32mm	40mm	50mm	65mm	80mm	100mm	125mm	150mm	
0.70	0.35	4.6	14	28.6	47.1	71.8	104	178	NA	NA	NA	NA	NA	
	0.07*	4.6	14	28.6	47.1	71.8	104	178	NA	NA	NA	NA	NA	
1.00	0.65	5.0	15.5	31.5	52.0	79.2	114	196	NA	NA	NA	NA	NA	
	0.55	5.4	16.4	33.5	55.2	84.2	122	209	NA	NA	NA	NA	NA	
	0.32*	5.4	16.4	33.5	55.2	84.2	122	209	357	445	797	NA	NA	
	0.07*	5.4	16.4	33.5	55.2	84.2	122	209	357	445	797	NA	NA	
2.00	1.65	6.3	19.3	39.5	65.0	99.1	143	246	NA	NA	NA	NA	NA	
	1.30	7.6	23.2	47.3	77.9	118	171	295	473	590	1057	1530	2180	
	1.10	8.3	25.3	51.6	85.0	129	187	322	516	643	1153	1819	2377	
	0.35	8.3	25.3	51.6	85.0	129	187	322	516	643	1153	1819	2377	
	0.07*	8.3	25.3	51.6	85.0	129	187	322	516	643	1153	NA	NA	
5.00	4.30	11.2	34.3	70.1	115	176	254	437	NA	NA	NA	NA	NA	
	4.00	12.8	39.1	79.8	131	200	289	497	765	954	1711	2477	3528	
	2.75	17.0	51.8	106	174	265	383	659	1057	1318	2363	3803	4871	
	0.35	17.0	51.8	106	174	265	383	659	1057	1318	2363	3803	4871	
	0.07*	17.0	51.8	106	174	265	383	659	1057	1318	2363	NA	NA	
10.00	9.00	17.4	53.3	108	179	272	394	678	912	1137	2039	2951	4204	
	5.50	31.0	94.5	193	317	484	699	1202	1928	2404	4309	7008	8882	
	1.20	31.0	94.5	193	317	484	699	1202	1928	2404	4309	7008	8882	
	0.35	31.0	94.5	193	317	484	699	1202	1928	2404	4309	NA	NA	
15.00	14.00	20.2	61.7	125	207	316	456	785	908	1132	2029	NA	NA	
	12.00	34.3	104	213	351	536	775	1332	2099	2618	4692	6792	9673	
	8.25	45.0	137	280	460	702	1014	1743	2796	3486	6249	10187	12882	
	2.90	45.0	137	280	460	702	1014	1743	2796	3486	6249	10187	12882	
	0.80*	45.0	137	280	460	702	1014	1743	2796	3486	6249	NA	NA	
20.00	19.00	22.8	69.7	142	234	356	515	886	892	1112	1994	NA	NA	
	12.00	57.5	175	357	589	897	1297	2229	3579	4459	7993	11569	16478	
	11.00	58.9	180	366	603	920	1329	2284	3664	4569	8190	13307	16882	
	4.60	58.9	180	366	603	920	1329	2284	3664	4569	8190	13307	16882	
	3.10	58.9	180	366	603	920	1329	2284	3664	4569	8190	NA	NA	
	1.28	58.9	180	366	603	920	1329	2284	NA	NA	NA	NA	NA	
25.00	20.70	51.7	157	321	530	807	1167	2006	3049	3802	6815	NA	NA	
	13.75	72.9	222	453	746	1137	1664	2826	4532	5651	10130	NA	NA	
	12.00	72.9	222	453	746	1137	1664	2826	4532	5651	10130	14662	20882	
	6.30	72.9	222	453	746	1137	1664	2826	4532	5651	10130	14662	20882	
	2.80	72.9	222	453	746	1137	1664	2826	NA	NA	NA	NA	NA	
30.00	20.70	78.3	238	487	802	1222	1767	3038	4872	6076	10891	NA	NA	
	16.50	86.8	265	540	889	1355	1959	3367	5400	6734	12070	NA	NA	
	12.00	86.8	265	540	889	1355	1959	3367	5400	6734	12070	17470	24882	
	8.00	86.8	265	540	889	1355	1959	3367	5400	6734	12070	17470	24882	
	6.90	86.8	265	540	889	1355	1959	3367	5400	6734	12070	NA	NA	
	4.60	86.8	265	540	889	1355	1959	3367	NA	NA	NA	NA	NA	
35.00	20.70	99.3	302	617	1017	1550	2241	3852	6178	7705	13811	NA	NA	
	19.25	101	307	627	1032	1573	2274	3908	6268	7817	14011	NA	NA	
	12.00	101	307	627	1032	1573	2274	3908	6268	7817	14011	20279	28882	
	9.60	101	307	627	1032	1573	2274	3908	6268	7817	14011	20279	28882	
	7.50	101	307	627	1032	1573	2274	3908	6268	7817	14011	NA	NA	
	6.20	101	307	627	1032	1573	2274	3908	NA	NA	NA	NA	NA	
	6.20	101	307	627	1032	1573	2274	3908	NA	NA	NA	NA	NA	
40.00	20.70	115	350	714	1175	1791	2589	4450	7136	8899	15951	NA	NA	
	12.00	115	350	714	1175	1791	2589	4450	7136	8899	15951	23088	32882	
	10.30	115	350	714	1175	1791	2589	4450	7136	8899	15951	23088	32882	
	8.07	115	350	714	1175	1791	2589	4450	7136	8899	15951	NA	NA	
	6.20	115	350	714	1175	1791	2589	4450	NA	NA	NA	NA	NA	
42.00	20.70	120	367	748	1233	1878	2715	4666	7483	9332	16728	NA	NA	
	12.00	120	367	748	1233	1878	2715	4666	7483	9332	16728	24211	34482	
	10.30	120	367	748	1233	1878	2715	4666	7483	9332	16728	24211	34482	
	8.30	120	367	748	1233	1878	2715	4666	7483	9332	16728	NA	NA	
	6.20	120	367	748	1233	1878	2715	4666	NA	NA	NA	NA	NA	

### Useful Conversions

SCFM = 1/sec x 2.12

Nm<sup>3</sup>/h = 1/sec x 3.60

\* Low pressure top required for outlet pressures below 0.35 Barg

1. The Max. & Min. outlet pressure for a given inlet pressure and valve size, can be determined from the above table. E.g. a 100mm valve with an inlet pressure of 40 Barg has a Maximum available outlet pressure of 20.7 Barg and a minimum of 8.07 Barg.
2. To ensure the above flows, it is critical the correct size of outlet pipe is used. See page 70.
3. For gases other than air and temperatures other than 15°C refer to page 40

## G4 PIPE SIZING

**CAPACITIES FOR STEAM IN kg/h** (For lbs/h multiply capacity by 2.2046.) See opposite for air capacities

Pressure in Psig	Pressure in Barg	PIPE SIZE (millimetres)														
		15	20	25	32	40	50	65	80	100	125	150	200	250	300	350
7.5	0.5	9 0.03	18 0.03	30 0.03	45 0.03	88 0.03	159 0.03	308 0.03	476 0.03	705 0.03	1270 0.03	1540 0.03	3080 0.02	4620 0.02	6810 0.02	9430 0.02
15	1.0	12 0.04	22 0.04	39 0.04	59 0.04	118 0.04	218 0.04	400 0.04	590 0.04	975 0.04	1630 0.04	2270 0.04	4000 0.03	6430 0.03	9480 0.03	13100 0.03
30	2.0	16 0.05	33 0.06	55 0.06	88 0.06	177 0.06	305 0.06	545 0.06	840 0.06	1475 0.06	2450 0.06	3500 0.06	6140 0.05	8920 0.04	13100 0.04	18200 0.04
45	3.0	20 0.07	44 0.08	75 0.08	118 0.09	241 0.10	419 0.10	795 0.09	1180 0.08	1900 0.08	3080 0.08	4400 0.08	8160 0.07	12400 0.06	16700 0.05	23200 0.05
60	4.0	24 0.10	54 0.10	97 0.11	147 0.12	309 0.13	545 0.12	1040 0.12	1500 0.12	2450 0.11	4080 0.11	5670 0.11	10200 0.10	16900 0.09	23500 0.08	30400 0.07
75	5.0	29 0.11	67 0.12	116 0.13	180 0.14	359 0.14	625 0.14	1180 0.14	1820 0.14	2950 0.13	4760 0.13	6670 0.13	13100 0.12	20300 0.11	28600 0.10	37500 0.09
90	6.0	36 0.12	76 0.14	136 0.15	211 0.16	427 0.16	750 0.16	1400 0.16	2130 0.16	3450 0.16	5800 0.16	7950 0.15	15000 0.14	23700 0.13	33600 0.12	44500 0.11
100	7.0	43 0.14	91 0.16	154 0.18	245 0.18	490 0.19	864 0.19	1650 0.19	2450 0.18	3950 0.18	6600 0.18	9300 0.17	17200 0.16	27100 0.15	38600 0.14	51500 0.13
115	8.0	48 0.15	104 0.17	182 0.20	272 0.21	545 0.22	955 0.22	1860 0.22	2640 0.20	4300 0.20	7270 0.20	10200 0.19	19000 0.18	30500 0.17	43700 0.16	58500 0.15
130	9.0	52 0.18	113 0.20	200 0.24	309 0.25	613 0.26	1140 0.26	2180 0.26	3090 0.25	5080 0.25	8650 0.25	12200 0.23	21800 0.22	34800 0.20	50000 0.19	65500 0.17
145	10.0	57 0.20	123 0.23	222 0.27	336 0.30	668 0.30	1200 0.30	2360 0.29	3400 0.28	5580 0.28	9550 0.28	13400 0.27	25000 0.26	39900 0.24	57500 0.23	76100 0.21
175	12.0	67 0.23	136 0.27	259 0.31	418 0.34	818 0.35	1450 0.35	2900 0.37	4090 0.36	6850 0.35	11500 0.35	16100 0.34	30000 0.31	47500 0.29	68700 0.28	91700 0.26
220	15.0	75 0.29	168 0.33	318 0.39	510 0.42	1020 0.44	1820 0.45	3640 0.46	5220 0.46	8600 0.46	14300 0.46	19700 0.43	33200 0.41	59000 0.39	84600 0.37	113900 0.35
260	18.0	93 0.35	227 0.40	395 0.46	617 0.49	1230 0.51	2270 0.52	4300 0.54	6450 0.55	10900 0.55	17700 0.55	24500 0.53	47600 0.51	74100 0.49	106900 0.47	144800 0.45
290	20.0	107 0.38	250 0.44	435 0.50	680 0.55	1360 0.57	2460 0.59	4760 0.62	7030 0.64	12200 0.64	20000 0.64	28200 0.63	54000 0.61	85400 0.59	123600 0.57	168100 0.55
360	25.0	134 0.47	287 0.54	522 0.61	838 0.66	1680 0.68	2890 0.71	5400 0.74	8790 0.76	14700 0.78	24200 0.78	36100 0.78	66600 0.76	106000 0.74	154000 0.72	210000 0.70
435	30.0	159 0.56	342 0.64	619 0.72	995 0.78	2010 0.82	3450 0.85	6470 0.89	10500 0.91	17600 0.93	28900 0.93	43100 0.93	79600 0.91	127100 0.89	185000 0.87	253400 0.85
510	35.0	186 0.66	399 0.75	721 0.84	1170 0.92	2370 0.98	4060 1.01	7550 1.04	12200 1.06	20400 1.08	33500 1.08	50100 1.08	92700 1.06	148200 1.04	216200 1.02	296400 1.00
580	40.0	214 0.76	456 0.86	820 0.95	1320 1.03	2690 1.10	4610 1.14	8550 1.17	13900 1.20	23300 1.23	38200 1.23	57100 1.23	105800 1.21	169400 1.19	247500 1.17	339700 1.15
610	42.0	221 0.79	420 0.89	847 0.99	1360 1.07	2770 1.14	4750 1.18	11900 2.20	14400 1.26	24100 1.29	39700 1.29	59200 1.29	109800 1.27	175800 1.25	256900 1.23	352800 1.21

**Estimated Air capacities** – multiply chart capacities as follows:

- (1) Multiply chart capacity by 0.66 to give Air flow in SCFM
- (2) Multiply chart capacity by 1.2 to give Air flow in Nm<sup>3</sup>/h

Estimated Air pressure drops:

For guidance multiply the chart pressure drop by 1.23 to give an approximate Air pressure drop.

**Note (1)** Figures in *blue italics* show pressure drops (Barg) for equivalent lengths equal to 360 pipe diameters. When using this table, allowance should be made for the effects of bends and fittings in the pipe line.

**Note (2)** All capacity values are based on acceptable pressure drops, not velocity per unit length of pipe. Higher pressure drops will result in higher steam velocities and increased noise levels.

**Example**

**Question:** What size pipe will pass 800 kg/h of dry saturated steam at 7 Barg?

50mm pipe will pass 864 kg/h at 7 Barg (Pressure drop over 18m (360 pipe diameters) will be approximately *0.19* Barg).



## AIR CAPACITIES

		C10 Air Capacity - l/s @ 15°C							
Inlet Pressure (Barg)	Outlet Pressure (Barg)	Rise to							
		Dead End	15mm	20mm	25mm	32mm	40mm	50mm	
1.00	0.65	20%	1.8	3.0	4.7	6.5	8.4	10.3	
	0.58	20%	2.0	3.3	5.1	7.0	9.1	11.1	
2.00	1.60	20%	3.3	5.5	8.3	11.6	15.0	16.4	
	1.00	20%	4.6	7.8	11.8	16.4	21.2	26.0	
	0.58	20%	4.9	8.2	12.5	17.4	22.5	27.6	
5.00	4.00	20%	9.0	15.0	23.0	31.9	41.2	50.5	
	3.00	20%	11.6	19.4	29.6	41.0	53.0	65.0	
	2.00	20%	12.3	20.6	31.4	43.5	56.3	68.9	
	0.58	20%	12.3	20.6	31.4	43.5	56.3	68.9	
10.00	4.00	20%	24.7	41.2	62.7	87.0	113	138	
	1.00	20%	24.7	41.2	62.7	87.0	113	138	
15.00	4.00	20%	37.0	61.8	94.0	130	169	207	
	1.50	20%	37.0	61.8	94.0	130	169	207	
20.00	4.00	20%	49.3	82.4	125	174	225	276	
	2.00	20%	49.3	82.4	125	174	225	276	
25.00	4.00	20%	61.7	103	157	217	282	345	
	2.50	20%	61.7	103	157	217	282	345	
27.00	4.00	20%	66.6	111	169	235	304	372	
	2.70	20%	66.6	111	169	235	304	372	

		Class T Air Capacity - l/s @ 15°C							
Inlet Pressure (Barg)	Outlet Pressure (Barg)	Rise to	15	20	25	32	40	50	
		Dead End	mm	mm	mm	mm	mm	mm	
0.70	0.35	0.35 Bar	8.3	16.3	25.0	53.2	76.1	124	
1.00	0.65	0.35 Bar	8.4	16.6	25.6	53.3	76.2	124	
	0.55	0.35 Bar	9.3	18.3	28.2	58.7	83.9	137	
	0.35	0.35 Bar	10.6	20.7	32.0	66.5	95.0	155	
5.00	4.64	0.35 Bar	11.7	22.4	35.7	62.7	89.8	151	
	4.20	0.7 Bar	23.8	45.6	72.7	128	183	308	
	4.00	1 Bar	34.0	65.2	104	183	262	441	
	2.50	1 Bar	46.4	88.8	142	249	357	601	
	0.35	1 Bar	46.4	88.8	142	249	357	601	
10.00	9.65	0.35 Bar	16.9	32.1	51.8	85.6	123	209	
	9.30	0.7 Bar	20.2	38.4	61.9	102	147	250	
	9.00	1 Bar	44.5	84.6	136	226	323	551	
	5.00	1 Bar	78.2	149	240	396	567	968	
	4.50	1 Bar	78.2	149	240	396	567	968	
	0.50	1 Bar	78.2	149	240	396	567	968	
20.70	12.80	1 Bar	142	267	434	687	985	1699	
	10.00	1 Bar	146	276	449	710	1017	1753	
	5.00	1 Bar	146	276	449	710	1017	1753	
	4.50	1 Bar	146	276	449	710	1017	1753	
	1.04	1 Bar	146	276	449	710	1017	1753	
30.00	12.80	1 Bar	205	387	631	983	1408	2435	
	3.00	1 Bar	205	387	631	983	1408	2435	
40.00	12.80	1 Bar	217	432	709	1110	1584	2709	
	4.00	1 Bar	217	432	709	1110	1584	2709	

Note: to achieve all the above flows, it is critical that the correct pipe sizes are used, refer to page 70

## SIZING GUIDELINES FOR AIR AND GAS DUTIES

The capacity sizing charts are for:

- 1) Critical pressure drop sizing.
- 2) Air.
- 3) Temperature of 15°C.
- 4) Units l/s.
- 5) Standard rise at dead end setting.

The following instructions will assist when the actual service conditions differ from the above criteria.

### 1) Critical Pressure Drop

The air capacity charts are based on critical pressure drop sizing. To achieve these flows, it is critical that the correct pipe sizes are used. Refer to page 70.

### 2) Other Gases

If you wish to use the valve on other compatible gases, the chart opposite can be used, however the capacity will change depending on the specific gravity of the flowing gas. Divide the valve air capacity by  $\sqrt{SG}$  to give the gas capacity  
(SG = specific gravity, relative to air = 1)

### 3) Other Temperatures

If the flowing temperature is not 15°C the chart capacity will need to be divided by  $\sqrt{(T/288)}$   
where: T = flowing temperature °C + 273°K

### 4) Useful Conversions

$m^3/h = l/s \times 3.6$   
 $CFM = l/s \times 2.12$

### 5) Non-Standard Rise at Dead End

For a definition of rise at dead-end see Page 56.  
To calculate capacities at a different rise at dead end multiply chart capacity by the below figures.

### Example:

Chart air capacity = 100 l/s  
SG of gas = 0.8  
Gas capacity of valve will be  
 $100 \div \sqrt{0.8} = 111.8 \text{ l/s (gas)}$

### Example:

Chart air capacity = 100 l/s  
Air temperature = 50°C (T = 323°K)  
Actual Air capacity at temperature will be:  
 $100 \div \sqrt{323/288} = 94.4 \text{ l/s (@ 50°C)}$

### Example:

Chart air capacity = l/s  
Valve type Class T  
Required rise at dead end 0.35 Barg  
Actual air capacity will become  
 $1000 \times 0.54 = 540 \text{ l/s}$

VALVE TYPE	RISE AT DEAD END				
<b>Class T</b>	0.35 Bar	0.7 Bar	1 Bar		Note: Only the capacity shown at 1 Bar rise can be adjusted
	0.54	0.77	1.0		
<b>C10</b>	5%	10%	15%	20%	Note: Only the capacity shown at 20% rise can be adjusted
	0.25	0.5	0.75	1.0	
<b>Bailey B</b>	20% (minimum 0.35 Bar)				

## WATER CAPACITIES

		C10 Water Capacity - l/s					
Pressure Differential (Barg)	Rise to Dead End	15mm	20mm	25mm	32mm	40mm	50mm
		1.00	1 Bar	0.56	0.90	1.42	2.08
2.00	1 Bar	0.73	1.17	1.83	2.69	3.71	4.98
3.00	1 Bar	0.83	1.33	2.09	3.06	4.23	5.68
4.00	1 Bar	0.90	1.44	2.26	3.32	4.58	6.15
5.00	1 Bar	0.93	1.48	2.32	3.41	4.71	6.33
6.00	1 Bar	0.94	1.50	2.35	3.45	4.76	6.40
7.00	1 Bar	0.94	1.51	2.36	3.47	4.79	6.44
8.00	1 Bar	0.94	1.51	2.36	3.47	4.79	6.44
9.00	1 Bar	0.94	1.51	2.36	3.47	4.79	6.44
10.00	1 Bar	0.94	1.51	2.36	3.47	4.79	6.44
15.00	1 Bar	0.94	1.51	2.36	3.47	4.79	6.44
20.00	1 Bar	0.94	1.51	2.36	3.47	4.79	6.44
24.30	1 Bar	0.94	1.51	2.36	3.47	4.79	6.44

		TH Water Capacity - l/s		
Pressure Differential (Barg)	Rise to Dead End	25mm	40mm	50mm
		2.00	1.20 Bar	2.56
3.00	1.40 Bar	2.74	4.64	7.83
4.00	1.60 Bar	2.92	4.95	8.17
5.00	1.65 Bar	3.10	5.25	8.50
6.00	1.75 Bar	3.28	5.55	8.83
7.00	1.80 Bar	3.45	5.85	9.16
8.00	1.85 Bar	3.63	6.16	9.50
9.00	1.95 Bar	3.81	6.46	9.83
10.00	2 Bar	3.99	6.76	10.16
15.00	2 Bar	4.12	6.98	10.50
20.00	2 Bar	4.25	7.21	10.84
25.00	2 Bar	4.39	7.43	11.17
30.00	2 Bar	4.52	7.66	11.51
35.00	2 Bar	4.65	7.88	11.85

		T Water Capacity - l/s					
Pressure Differential (Barg)	Rise to Dead End	15 mm	20 mm	25 mm	32 mm	40 mm	50 mm
		1.00	1 Bar	0.98	1.28	1.90	2.60
2.00	1 Bar	1.32	1.72	2.56	3.51	4.34	6.53
3.00	1 Bar	1.51	1.98	2.94	4.02	4.99	7.50
4.00	1 Bar	1.61	2.11	3.15	4.29	5.31	7.98
5.00	1 Bar	1.71	2.24	3.32	4.54	5.63	8.47
6.00	1 Bar	1.78	2.32	3.45	4.73	5.86	8.80
7.00	1 Bar	1.85	2.41	3.59	4.91	6.08	9.14
8.00	1 Bar	1.92	2.50	3.72	5.09	6.31	9.47
9.00	1 Bar	1.98	2.59	3.85	5.27	6.53	9.82
10.00	1 Bar	2.05	2.68	3.99	5.46	6.76	10.16
15.00	1 Bar	2.12	2.77	4.12	5.64	6.98	10.50
20.00	1 Bar	2.19	2.86	4.25	5.82	7.21	10.84
25.00	1 Bar	2.26	2.95	4.38	6.00	7.43	11.18
30.00	1 Bar	2.33	3.04	4.52	6.18	7.66	11.51
35.00	1 Bar	2.40	3.13	4.65	6.37	7.88	11.85

## SIZING GUIDELINES FOR WATER AND OTHER LIQUIDS

The capacity sizing charts are for:

- 1) Water.
- 2) Units l/s.
- 3) Standard rise at dead end setting.

The following instructions will assist when the actual service conditions differ from the above criteria.

### 1) Other Liquids

If you wish to use the valve on other compatible liquids, the sizing chart opposite can be used. However, the valve capacity will change depending on the specific gravity of the flowing liquid. Divide the valve water capacity by  $\sqrt{SG}$  to give the liquid capacity. (SG = specific gravity, relative to water =1.)

#### Example:

Chart water capacity = 2 l/s

SG of liquid = 0.8

Liquid capacity of valve will be

$$2 \div \sqrt{0.8} = 2.24 \text{ l/s (liquid).}$$

### 2) Useful Conversions

$$\text{lgpm} = \text{l/s} \times 13.33$$

$$\text{m}^3/\text{min} = \text{l/s} \times 0.06$$

### 3) Non-Standard Rise at Dead End

For a definition of rise at dead end see Page 56

**Standard rise at dead end is 1 barg.**

To determine the capacity at a different rise at dead end, multiply the water capacity by the following factors.

#### Example:

Chart water capacity = 2 l/s

Valve Type C10

Size 1"

Required rise at dead end 1.4 barg

actual water capacity will become

$$2 \times 1.190 = 2.38 \text{ l/s}$$

TYPE & SIZE	RISE AT DEAD END		
	0.35 Bar	0.7 Bar	1.4 Bar
<b>T</b> ½" to 4"	0.625	0.813	—
<b>5" to 6"</b>	—	0.770	1.230
<b>C10</b> ½" to 1"	0.340	0.720	1.190
<b>1¼" to 2"</b>	0.260	0.680	1.290
<b>TH</b>	Other rises are not available		

Note. The capacity is unaffected by changes in temperature.

## SATURATED STEAM CAPACITIES

Inlet Pressure Barg (psig)	Outlet Pressure Barg (psig)	Bailey B Dry Saturated Steam Capacities - Kg/hr					
		15mm (1/2")	20mm (3/4")	25mm (1")	32mm (1 1/4")	40mm (1 1/2")	50mm (2")
1.72 (25)	1.03(15)	40	57	92	137	160	257
	0.69(10)	40	57	92	137	160	257
3.45 (50)	2.67(40)	59	83	133	200	233	375
	1.72(25)	62	95	152	229	267	429
	0.69(10)	62	95	152	229	267	429
5.17 (75)	4.48(65)	63	89	143	215	251	403
	3.45(50)	84	119	191	286	334	537
	1.72(25)	108	155	248	372	434	697
	1.69(10)	108	155	248	372	434	697
6.9 (100)	6.21(90)	70	105	168	254	297	476
	5.17(75)	133	191	305	457	533	857
	3.45(50)	136	194	310	465	542	872
	1.72(25)	136	194	310	465	542	872
8.62 (125)	6.70(100)	121	200	320	457	528	900
	5.17(75)	175	249	400	599	699	1124
	3.45(50)	181	260	415	624	727	1169
	1.72(25)	181	260	415	624	727	1169
10.34 (150)	9.66(140)	57	95	159	238	279	451
	8.62(125)	178	254	406	610	711	1143
	6.70(100)	184	262	419	629	734	1181
	5.17(75)	217	310	496	743	867	1394
	3.45(50)	217	310	496	743	867	1394
13.79 (200)	10.34(150)	206	294	470	705	823	1323
	8.28(120)	243	346	554	831	269	1558
	6.70(100)	284	405	648	972	1134	1823
	5.17(75)	284	405	648	972	1134	1823
15.52 (225)	10.34(150)	304	434	695	1042	1216	1954
	8.28(120)	340	486	778	1167	1362	2188
	6.70(100)	365	520	832	1248	1457	2341
	5.17(75)	365	520	832	1248	1457	2341
17.2 (250)	10.34(150)	311	445	711	1087	1245	2000
	8.62(125)	403	575	919	1378	1608	2585
	6.70(100)	403	575	919	1378	1608	2585

Note: to achieve all the above flows, it is critical that the correct pipe sizes are used, refer to page 70

## SIZING GUIDELINES FOR STEAM

The capacity charts are for:

- 1) Critical pressure drop sizing.
- 2) Dry saturated steam.
- 3) Units kg/h.

The following instructions will assist when the actual service conditions differ from these criteria.

### 1) Critical Pressure Drop

The above steam capacity chart is based on critical pressure drop sizing. To achieve these flows, it is critical that the correct pipe sizes are used. Refer to page 70.

### 2) Super Heated Steam

Most systems usually use saturated steam. However, if the steam temperature is greater than the saturated steam temperature the extra temperature will decrease the flow through the valve. Refer to office for details.

### 3) Useful Conversions

1b/hr = Kg/h x 2.2046.

## CLASS F HOSE PRESSURE REGULATOR SIZING

To determine the flow rate through the valve, it is necessary to know the available inlet 'flowing' pressure and the required outlet 'flowing' pressure.

Firstly you need to work out the differential 'flowing' pressure (i.e. inlet minus outlet pressures).

Secondly, based on the required outlet flowing pressure, refer to either graph 1 or 2, which are only valid for the appropriate 'flowing' outlet pressure range.

Thirdly, from the differential 'flowing' pressure read the corresponding flow rate.

e.g. Inlet 'flowing' pressure = 7 Barg,  
outlet 'flowing' pressure = 4 Barg.

Therefore:

- 1) Differential 'flowing' pressure =  $7 - 4 = 3$  Barg.
- 2) As outlet 'flowing' pressure is 4 Barg, use graph 1 (3.4 - 4.8 Barg).
- 3) A differential 'flowing' pressure of 3 Barg corresponds to an approximate flow rate of 12.5 l/s.

To size a valve in SPO mode please consult one of our Bailey Technical Sales Engineers, who will be pleased to assist.

**Note:**

Regardless of connection size the valve size is 1½", hence the capacity is always that of a 1½" valve.

Rise at dead end (see page 56) will be 0.7 Barg.

**GRAPH 1**

'Flowing' outlet pressure range: 3.4-4.8 Barg

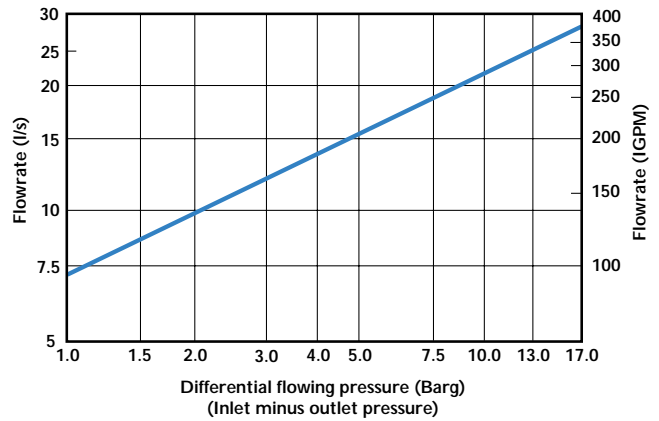

**GRAPH 2**

'Flowing' outlet pressure range: 4.8-7.6 Barg

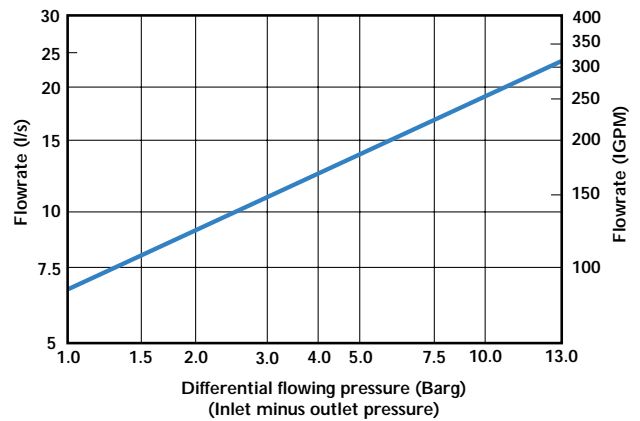

# Spring Selection Charts

## 480/490 AND 616D SPRING SELECTION

The valves are fitted with a suitable spring. Every valve is tested thoroughly for efficient operation before leaving our factory. Ensure the set pressure is within the range of the existing spring. If not, select and fit the correct spring from the tables below. All our springs are low stressed and painted to minimise corrosion.

480/490 Series Spring Range and Selection			616D Series Spring Range and Selection		
Barg	Psig	Colour Code	Barg	Psig	Colour Code
0.3 - 0.7	5 - 10	Yellow	0.21 - 0.38	3.1 - 5.5	Red
0.7 - 1.0	10 - 15	Blue	0.38 - 0.67	5.5 - 9.8	Yellow
1.0 - 1.7	15 - 25	Orange	0.67 - 0.99	9.8 - 14.4	Blue
1.7 - 3.4	25 - 50	Purple	0.99 - 1.30	14.4 - 18.9	Orange
3.4 - 5.2	50 - 75	Green/Blue	1.30 - 2.5	18.9 - 36.3	(DN40) Purple
5.2 - 6.9	75 - 100	Green	1.30 - 2.07	18.9 - 30.0	(DN50) Purple
6.9 - 10.3	100 - 150	White	2.07 - 2.20	30.0 - 31.9	(DN50) C2901
10.3 - 13.8	150 - 200	Red/Yellow	2.20 - 2.50	31.9 - 36.3	(DN50) C2902
13.8 - 17.2	200 - 250	Red/Green			
17.2 - 20.7	250 - 300	Red/Orange			
20.7 - 24.0	300 - 350	Yellow/Blue			

Note: 80mm valve max pressure is 10 Barg (147 Psig)

Springs listed above comply with the requirements of BS6759: Part 1.

## 707 SPRING SELECTION

DN15 Spring Range				DN32 Spring Range			
Part No	Barg	Psig	Colour code	Part No	Barg	Psig	Colour code
C2193	0.35 - 1.0	5 - 15	Red	C2220	0.35 - 1.0	5 - 15	Red
C2194	1.0 - 1.7	15 - 25	Blue	C0174	1.0 - 1.7	15 - 25	Blue
C2195	1.7 - 2.4	25 - 35	Orange	C2213	1.7 - 2.4	25 - 35	Orange
C2196	2.4 - 3.5	35 - 50	Orange/Blue	C2221	2.4 - 4.1	35 - 60	Orange/Blue
C2197	3.5 - 5.5	50 - 80	Green/White	C2214	4.1 - 5.5	60 - 80	Purple
C2198	5.5 - 8.3	80 - 120	Green/Blue	C2222	5.5 - 8.3	80 - 120	Green/White
C2199	8.3 - 15.9	120 - 230	White/Blue	C2215	8.3 - 10.3	120 - 150	Green/Blue
C3235	15.9 - 19.3	230 - 280	Red/Orange	C2223	10.3 - 12.5	150 - 180	White/Blue
C3236	19.3 - 24.1	280 - 350	Yellow/Blue	C3241	12.5 - 19.3	180 - 280	Red/Orange
				C3242	19.3 - 24.1	280 - 350	Yellow/Blue

DN20 Spring Range				DN40 Spring Range			
Part No	Barg	Psig	Colour code	Part No	Barg	Psig	Colour code
C2187	0.35 - 1.0	5 - 15	Red	C2224	0.35 - 1.0	5 - 15	Red
C2188	1.0 - 1.7	15 - 25	Blue	C2216	1.0 - 1.7	15 - 25	Blue
C2189	1.7 - 3.5	25 - 50	Orange	C0709	1.7 - 2.4	25 - 35	Orange
C2190	3.5 - 6.9	50 - 100	Orange/Blue	C2225	2.4 - 4.1	35 - 60	Orange/Blue
C2191	6.9 - 10.3	100 - 150	Purple	C2226	4.1 - 5.5	60 - 80	Purple
C2192	10.3 - 13.8	150 - 200	Green/White	C2217	5.5 - 8.3	80 - 120	Green/White
C3237	13.8 - 20.7	200 - 300	Red/Orange	C2208	8.3 - 10.3	120 - 150	Green/Blue
C3238	20.7 - 24.1	300 - 350	Yellow/Blue	C2218	10.3 - 12.5	150 - 180	White/Blue
				C3243	12.5 - 15.9	180 - 230	Red/Green
				C3244	15.9 - 19.3	230 - 280	Red/Orange
				C3245	19.3 - 24.1	280 - 350	Yellow/Blue

DN25 Spring Range				DN50 Spring Range			
Part No	Barg	Psig	Colour code	Part No	Barg	Psig	Colour code
C0139	0.35 - 1.0	5 - 15	Red	C2227	0.35 - 1.0	5 - 15	Red
C0145	1.0 - 1.7	15 - 25	Blue	C0718	1.0 - 1.7	15 - 25	Blue
C0147	1.7 - 2.4	25 - 35	Orange	C0719	1.7 - 2.4	25 - 35	Orange
C2182	2.4 - 4.1	35 - 60	Orange/Blue	C2219	2.4 - 4.1	35 - 60	Orange/Blue
C2183	4.1 - 5.5	60 - 80	Purple	C2228	4.1 - 5.5	60 - 80	Purple
C2184	5.5 - 8.3	80 - 120	Green/White	C2229	5.5 - 8.3	80 - 120	Green/White
C2185	8.3 - 12.5	120 - 180	Green/Blue	C2209	8.3 - 10.3	120 - 150	Green/Blue
C3239	12.5 - 19.3	180 - 280	Red/Orange	C2230	10.3 - 12.5	150 - 180	White/Blue
C3240	19.3 - 24.1	280 - 350	Yellow/Blue	C0724	12.5 - 17.2	180 - 250	Red/Yellow
				C3246	17.2 - 24.1	250 - 350	Yellow/Blue

Springs listed above comply with the requirements of BS EN ISO 4126: Part 7 and BS6759: Part 1

• Spring charts for 716H/746/756/766/776 are available on request.



## 716 SPRING SELECTION

### DN15 Spring Range

Part No	Barg	Psig	Colour code
C0074	0.35 – 1.0	5 – 15	Red
C2133	1.0 – 1.7	15 – 25	Blue
C2134	1.7 – 2.4	25 – 35	Orange
C2135	2.4 – 4.1	35 – 60	Orange/Blue
C2136	4.1 – 6.9	60 – 100	Green/White
C2137	6.9 – 10.3	100 – 150	Green/Blue
C2138	10.3 – 12.4	150 – 180	White/Blue
C2181	12.4 – 15.5	180 – 225	—
C0623	15.5 – 18.6	225 – 270	White
C2169	18.6 – 22.1	270 – 320	—
C0645	22.1 – 26.5	320 – 384	Red/Yellow
C2201	26.5 – 27.6	384 – 400	—
C0651	27.6 – 32.0	400 – 464	Red/Green

### DN32 Spring Range

Part No	Barg	Psig	Colour code
C0452	0.35 – 1.0	5 – 14	Red
C0457	1.0 – 1.7	14 – 25	Blue
C0461	1.7 – 3.1	25 – 45	Orange
C0467	3.1 – 4.1	45 – 60	Orange/Blue
C0469	4.1 – 5.5	60 – 80	Purple
C0472	5.5 – 8.6	80 – 125	Green/White
C0475	8.6 – 10.3	125 – 150	Green/Blue
C0476	10.3 – 12.8	150 – 185	White/Blue
C0477	11.4 – 13.8	166 – 200	—
C0478	12.6 – 15.2	183 – 220	—
C0479	13.9 – 16.8	202 – 243	—
C0480	15.4 – 18.5	223 – 268	—

### DN20 Spring Range

Part No	Barg	Psig	Colour code
C0686	0.35 – 1.0	5 – 14	Red
C0688	1.0 – 2.1	14 – 30	Blue
C0689	2.1 – 2.8	30 – 40	Orange
C2125	2.8 – 3.8	40 – 55	Orange/Blue
C0690	3.8 – 5.5	55 – 80	Purple
C2126	5.5 – 7.6	80 – 110	Green/White
C0691	7.6 – 10.3	110 – 150	Green/Blue
C2127	10.3 – 12.4	150 – 180	White/Blue
C2178	12.4 – 15.5	180 – 225	—
C0693	15.5 – 18.6	225 – 270	White
C2170	18.6 – 20.3	270 – 295	—
C0694	20.3 – 24.5	295 – 355	Red/Yellow

### DN40 Spring Range\*

Part No	Barg	Psig	Colour code
C0508	0.35 – 1.0	5 – 14	Red
C0492	1.0 – 1.7	14 – 25	Blue
C0495	1.7 – 3.1	25 – 45	Orange
C0498	3.1 – 4.1	45 – 60	Orange/Blue
C0499	4.1 – 5.5	60 – 80	Purple
C0501	5.5 – 8.6	80 – 125	Green/White
C0503	8.6 – 10.3	125 – 150	Green/Blue
C0504	10.3 – 12.8	150 – 185	White/Blue
C0505	11.4 – 13.8	166 – 200	—
C0506	12.6 – 15.2	183 – 220	—
C0507	15.4 – 18.5	223 – 268	—

### DN25 Spring Range

Part No	Barg	Psig	Colour code
C2119	0.35 – 1.0	5 – 14	Red
C2120	1.0 – 1.7	14 – 25	Blue
C2121	1.7 – 3.1	25 – 45	Orange
C2114	3.1 – 4.1	45 – 60	Orange/Blue
C2113	4.1 – 5.5	60 – 80	Purple
C2122	5.5 – 8.6	80 – 125	Green/White
C2123	8.6 – 10.7	125 – 155	Green/Blue
C2124	10.7 – 12.8	155 – 185	White/Blue
C2202	12.8 – 13.2	185 – 192	—
C2234	13.2 – 15.4	192 – 223	—
C2203	15.4 – 17.6	223 – 255	—
C2235	17.6 – 20.5	255 – 297	—

### DN50 Spring Range\*

Part No	Barg	Psig	Colour code
C0919	0.35 – 1.0	5 – 14	Red
C0922	1.0 – 1.7	14 – 25	Blue
C0924	1.7 – 3.1	25 – 45	Orange
C1400	3.1 – 4.1	45 – 60	Orange/Blue
C0928	4.1 – 5.5	60 – 80	Purple
C0930	5.5 – 8.6	80 – 125	Green/White
C0933	8.6 – 10.3	125 – 150	Green/Blue
C0934	10.3 – 12.8	150 – 185	White/Blue
C0935	11.4 – 13.8	166 – 200	—
C0936	12.8 – 15.4	185 – 223	—
C0937	14.5 – 17.4	210 – 253	—
C0939	15.4 – 18.5	223 – 268	—

Springs up to 12.5 Barg (181 Psig) listed above for all materials comply with the requirements of BS6759:Part 1.

The cast iron 716 is only available up to 13 Barg (188 Psig) on any medium.

The stainless steel 716 is only available up to 12.5 Barg (181 Psig) on any medium.

Stainless steel springs are available for 716 to the same pressures as shown above.

\*DN40 and DN50 716 valves with PTFE trim can not have their springs selected from the above two charts. Refer to factory.

## G4 SPRING SELECTION

If possible it is advisable to select a spring which has at least 10% additional adjustment above the required set pressure. As can be seen from the chart, the springs have overlapping ranges. Where possible the spring with the lowest range should be selected.

15-100mm (½" - 4") VALVES		
Barg	(Psig)	Colour Code
0.07-3.5	(1-50)	Yellow
0.7-7.0	(10-100)	Black
2.8-10.5	(40-150)	White
3.5-14.0	(50-200)	Green
7.0-21.0	(100-300)	Red

150mm (6")* VALVES		
Barg	(Psig)	Colour Code
0.35-1.4	(5-20)	Red
0.7-3.5	(10-50)	Yellow
2.8-7.0	(40-100)	Black
3.5-12.0	(50-175)	Green

\*A 150mm body can be offered with a restricted main valve to give a 125mm size flow rate.

## BAILEY B SPRING SELECTION

Size	Spring Ranges Working Range Barg	Maximum Psig	Part Number
DN15 (½")	0.14-2.07	2-30	110
	0.69-3.45	10-50	111
	2.07-8.62	30-125	113
	3.45-10.34	50-150	8805
DN20 (¾")	0.14-1.39	2-20	110
	0.69-2.41	10-35	111
	2.07-5.17	30-75	113
	3.45-6.70	50-100	8805
DN25 (1")	0.14-1.39	2-20	110
	0.69-2.41	10-35	111
	2.07-5.17	30-75	113
	3.45-6.70	50-100	8805
DN32 (1¼")	0.14-1.03	2-15	5356
	0.69-2.07	10-30	737
	1.36-4.14	20-60	1163
	3.79-6.70	55-100	1303
DN40 (1½")	0.14-1.03	2-15	5356
	0.69-2.07	10-30	737
	1.38-3.46	20-50	1163
	3.10-6.70	45-100	1303
DN50 (2")	0.14-0.69	2-20	5357
	0.69-4.14	10-60	3135
	1.38-6.70	20-100	760
	6.12-10.34	90-150	1904

## CLASS T SPRING SELECTION

DEAD END PRESSURE SETTING RANGE (Barg)	DEAD END PRESSURE SETTING RANGE (Psig)	COLOUR CODE
0.35 to 0.7	5 to 10	Dark Green
0.7 to 1.4	10 to 20	Light Green
1.4 to 2.8	20 to 40	Orange
2.8 to 5.5	40 to 80	Brown
5.5 to 8.3	80 to 120	Blue
8.3 to 13.8	120 to 200	Red

## C10 SPRING SELECTION

DEAD END PRESSURE SETTING RANGE (Barg)	DEAD END PRESSURE SETTING RANGE (Psig)	COLOUR CODE
0.7 to 4.8	10 to 70	Only 1 Spring

## CLASS TH SPRING SELECTION

Dead End Setting Barg	Spring Number			Springs Colour Code
	DN25 (1")	DN40 (1.5")	DN50 (2")	
3 to 15	C2957-425	C2954-425	C2960-425	White
1 to 7	-	C3197-425	C3196-425	Purple
>7 to 20	C3019-425	C2959-425	C2961-425	Yellow

Dead End Setting = Flowing outlet pressure + Rise to dead end

## CLASS F SPRING SELECTION

DEAD END PRESSURE SETTING RANGE (Barg)	DEAD END PRESSURE SETTING RANGE (Psig)	COLOUR CODE
4.1 to 5.5	60 to 80	Brown
5.5 to 8.3	80 to 120	Blue



Safety Systems UK Ltd.  
Sharp Street, Worsley, Manchester, UK, M28 3NA.  
Tel +44 (0)161 703 1899  
Fax +44 (0)161 703 8451  
Email [support@safetysystemsuk.com](mailto:support@safetysystemsuk.com)  
Web site [www.safetysystemsuk.com](http://www.safetysystemsuk.com)

**Safety  
Systems**  
UK Ltd.



Registered Office:  
Victoria Road, Leeds,  
LS11 5UG, UK