

**NEXT DAY
DELIVERY**

**SPECIALIST DISTRIBUTOR
OF SAFETY RELIEF
AND REDUCING VALVES**

flowstar

The Company

With the major changes that are taking place in most markets today and with more and more companies either merging or being taken over by global players. Then the very focused niche supplier still carrying stock of specialist products such as **safety, safety relief and reducing valves**, with the additional ability to customise products on site, becomes almost unique!

In the case of Flowstar, started in Hull over fourteen years ago, as a specialist but independent distribution company for the “**Quality Broady Valves**” (which were normally a works delivery) has seen considerable changes over the past few months. From the product range expansion which now includes **Niezgodka** (a specialist German valve producer complimenting the existing Broady safety relief valve products) and other valve types.

In addition to the increased product offering now available, Flowstar is also under new management, has a new marketing focus and has updated its IT system to match the new market demands. As an already key supplier to many large UK distribution companies, OEM's and large blue chip end users, Flowstar is re-emphasising its niche position of an **ex stock safety, safety relief and reducing valve supplier with on site spring changing and**

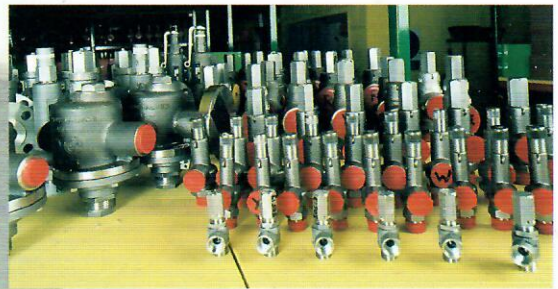

testing facilities with the focus on “**fast response**” and **customer service**.

Contact our technical sales for all your valve requirements on
01482 210 484

They will be pleased to help!

Flowstar (U.K.) Limited,
Unit 1, Gillett Street, Hull, East Yorkshire HU3 4JA
TELEPHONE: 01482 210484
FAX: 01482 586064
Email: sales@flowstar.co.uk

FLOWSTAR



PRESSURE REDUCING VALVES

Broady Type C6/C3 Pressure Reducing Valve

Type C6: Direct acting - nozzle design manufactured in Bronze in sizes 1/4" - 1 1/4" for use in Gases and Liquids. Available with either screwed or flanged connections. Inlet pressure range 41 BAR (G) for Gases and Liquids and 17 BAR (G) for Steam. Reduced pressure range .2 - 10 BAR (G) Higher inlet pressure can be accommodated. Please consult technical sales for further information.

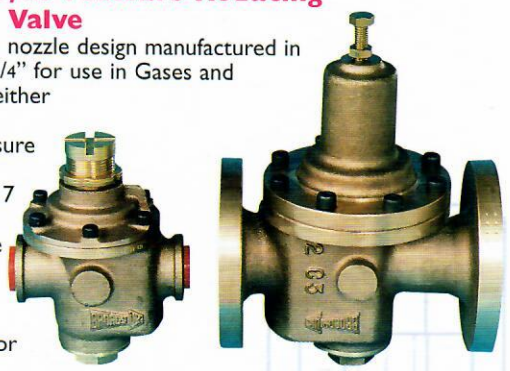

TYPE C3: Valves are as above but manufactured in sizes 1 1/2" - 4".
TYPE C9: Valves are for high pressure applications up to 82.75 BAR (G), which fall outside the parameters of C6/C3 range. Consult Flowstar for details.

Broady Type A/AB Pressure Reducing Valve

Direct acting pressure reducing valves for use with Gases and Liquids. Manufactured in S.G. Iron with screwed connections in sizes 1/2" - 2" only.

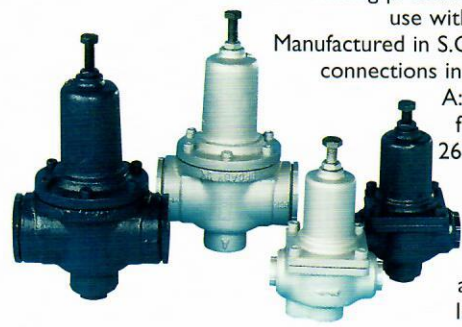

A: Unbalanced version for steam duty up to 260oc and 300psi inlet pressures.
AB: Balanced version for Gases and Liquids. WRC approval on request. Inlet pressures up to 28 BAR (G)
Reduced pressure range 0.7 - 8.3 BAR (G)

Broady Type C7/C8 Pressure Reducing Valve

As Type C6 but supplied in either Carbon Steel (Type C7) or Stainless Steel (Type C8) in sizes 1/2" - 2" and can have either screwed or flanged connections.



Broady Type 'D' Pressure Reducing Valve

The Broady Balflo 'D' Series is a high performance pressure reducing valve specifically designed for fluid service. Principle features include high capacity, balanced internal parts which permit fluctuating inlet pressures ensuring a stable reduced pressure and tight shut-off under no flow conditions. Sizes: 1/2"-2" screwed or flanged (in Bronze) 2 1/2" - 8" flanged only (in S.G. Iron). Maximum inlet pressure: 20 BAR (G). Reduced pressure ranges .35 - 13.8 BAR (G). Standard materials: Bronze or S.G. Iron. WRC approval on request.

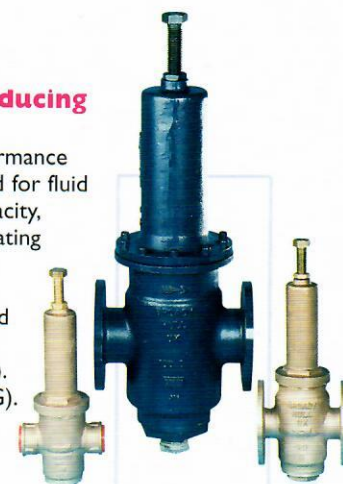

PRESSURE / SAFETY RELIEF VALVES

Broady Series 2600 Safety Relief Valves

Total lift, full nozzle spring type for Gas, Liquid and Vapour service, designed, manufactured and tested in accordance with API standards 520, 526 and 527.

Available with screwed NPT male and female or flanged connections. Sizes 1/2" x 1" to 1" x 1".

Standard materials of construction: Carbon Steel and Stainless Steel (other materials available on request)

Accessories: Levers, Limit Switches and Gags.



Broady Type 180/180S Relief Valves

Proportional lift type relief manufactured in Bronze in sizes 1/2" - 3" inclusive with either metal to metal or Nitrile/Viton soft seats for Gas, Liquid and Vapour service.

Standard end connections male inlet and female outlet with threads to BSP Parallel. Alternative threading available on request. Flanged connections are available.

Suitable for pressures up to 24 BAR G (1/2" - 2") and 10 BAR (G) (2 1/2" - 3"). Also manufactured in Stainless Steel in sizes 1/2" - 2" inclusive (type 180s)

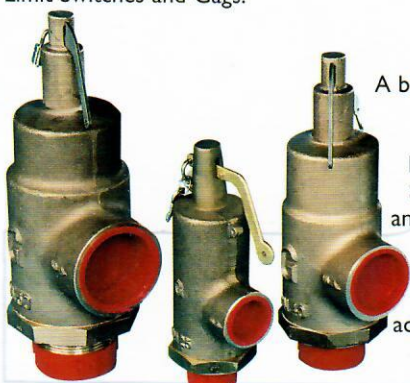

Type 76A

A bronze full lift wing guided pop type safety valve with lever and padlock. Suitable for steam and compressed air. Available 1/2" to 2" (0/300 PSIG) Manufactured in accordance with BS 6759 Pts. 1&2.



Ni Safety Valve Type 1.1 & 1.2

Totally enclosed right angle safety valve with screwed ends.

Type 1.1 with SG iron body, stainless steel trim.

Type 1.2 with stainless steel body and trim.

Both valves available soft seat (various options) or metal seat design and can be fitted with easing lever. Connections screwed BSP 3/8" to 2" or NPT 1/2" - 1"

Suitable for air, water, oil, gases, steam etc. (In future as overflow valve ACC to Ce-certification, directive 97/23/EC <<PED>>).

SET PRESSURE RANGES

3/8" to 1" to 670 BAR G

1 1/4" to 1" 0.05 to 90 BAR G

1 1/2" & 2" to 1" 0.05 to 45 BAR G

Ni Pressure Reducing Valves Type 75.2

Direct acting stainless steel pressure reducing valve with soft seat.

Suitable for steam, gases and liquids
Body stainless steel with soft seat and rubber diaphragm.

Size range: 15mm to 50mm
End connections flanged to DIN, ANSI or BS standards.

Inlet pressure maximum 25 BAR G
Outlet pressure 0.01 to 0.3 BAR G
Valve is balanced design giving stable outlet pressure even with varying inlet pressure.

All valves include 1/4" BSP gauge connection.

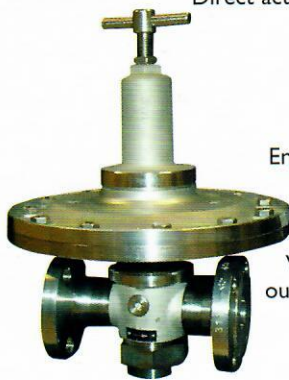

Broady Type B2 Pressure Reducing Valve

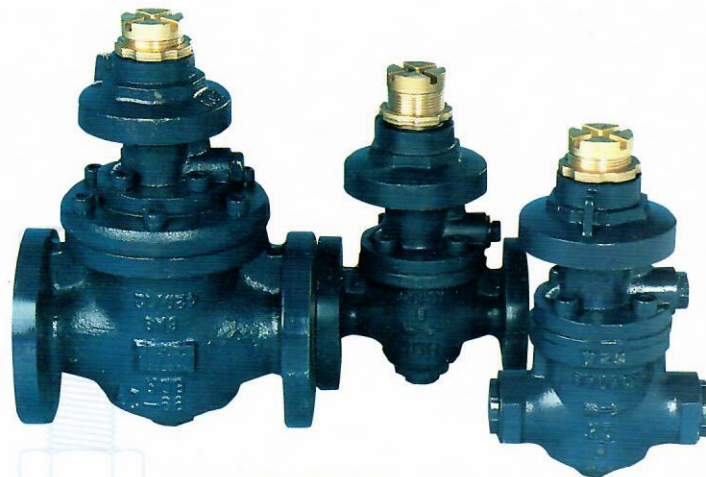

Pilot operated valve combines high capacity with accurate pressure reduction for both Steam and Gases. Suitable for all industries from Petrochemical to Hospital services. Manufactured in sizes 1/2" - 6" inclusive in Spheroidal Graphite Iron with flanged or screwed (up to 1 1/4" only) connections. Fitted with PTFE soft faced seat for Air and Gases, Stainless Steel diaphragm and seat for Steam applications. Reduced pressure range .3 - 18 BAR (G). Available in either Cast Steel or Stainless Steel for high temperature and pressure applications of to 70 BAR (G). For low pressure duties please consult Flowstar Technical Sales

Ni Pressure Reducing Valves Type 70.2 & 71.2

Direct acting stainless steel pressure reducing valve with soft seat.
For use with air, water, oil, gas, steam etc.

Type 70.2 with screwed ends

Type 71.2 with flanged ends

Type 70.2 screwed BSP 1/4" to 2" NPT
option 1/2" to 1"

Inlet pressure maximum 100 BAR G
Outlet pressure 0.15 to 80 BAR G
Soft seals to suit duty

Type 71.2 flanged 15mm to 125mm
Flanges to DIN, ansi OR BS Standards
Inlet pressure maximum 100 BAR G
Outlet pressure 0.15 to 80 BAR G

Valves are balanced design giving stable outlet pressure even with varying inlet pressure.
(All valves include 1/4" BSP gauge connection) High pressure version available on request.



HYGIENIC VALVES

Ni Safety Valve Type 3.1/3.2

Totally enclosed right angle safety valve with flanged ends.

Type 3.1 with carbon steel or SG iron body, stainless steel trim.

Type 3.2 with stainless steel body and trim.

Both valves available soft seat (various options) or metal seat design and can be fitted with easing lever. Flanged ends to DIN, ANSI or BS standards.

Size range 15mm to 100mm.
Suitable for air, water, oil, gases, steam etc. (In future as overflow valve ACC to Ce-certification, directive 97/23/EC <<PED>>).

SET PRESSURE RANGES

15mm to 25mm 0.1 to 250 BAR G

132mm to 65mm 0.1 to 100 BAR G

100mm to 65mm 0.25 to 63 BAR G

15mm to 100mm to 65mm 0.25 to 40 BAR G



Ni Safety Valve Type 5.3 & 5.2

Totally enclosed right angle safety valve.

Type 5.3 with brass body/soft seat.

Type 5.2 with stainless steel body/soft seat.

SIZE RANGES: 1/4" BSP inlet x 3/8" BSP outlet
3/8" BSP inlet x 3/8" BSP outlet
1/4" NPT inlet x 3/8" BSP outlet (5.2 only)

SET PRESSURE RANGES:

Type 5.3 0.5 to 65 BAR G

Type 5.2 0.2 to 200 BAR G

SEAT MATERIAL: Standard viton (options from EPDM Kalrez)(In future as overflow valve ACC to Ce-certification, directive 97/23/EC <<PED>>).

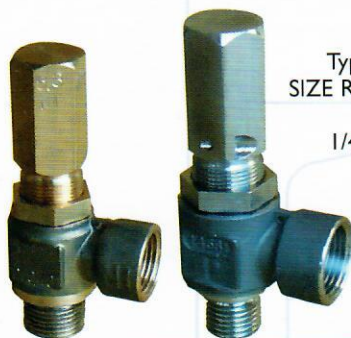

Ni Hygienic Valves

Stainless steel safety and reducing valves with hygienic connections for use in the Pharmaceutical, food, brewing and allied industries. Manufactured in stainless steel 1.4571 or special AISI 316L with option of polished surfaces. Tri clamp connections or alternative types available.

Size range from 1/2" to 2".
Full product details available on request.



OTHER QUALITY PRODUCTS AVAILABLE FROM FLOWSTAR



Bronze, gate, globe and check valves, drilled, undrilled and screwed BSP, available in sizes 1/2" to 12". Lloyds, BV, DNV certification facilities available on request.

Actuation to ball, butterfly, globe and gate valves in electric / pneumatic operation. Accessories including solenoid, visual display beacon, fire safety etc.

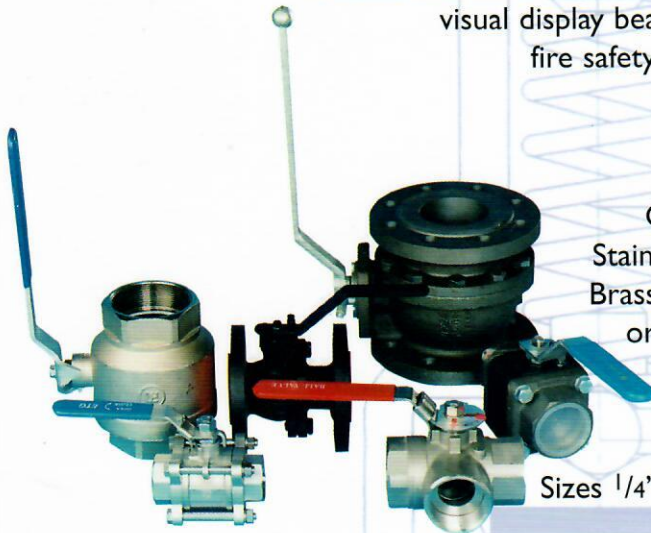

Cast Iron / Carbon / Stainless Steel / Bronze / Brass ball valves screwed or flanged with lever / 'T' handle / gear / pneumatic or electric actuation. Sizes 1/4" to 24", all pressure classes available.

Cast / Ductile Iron / Carbon / Stainless Steel, wafer / lugged / double flanged butterfly valves available with coated iron, stainless steel disc and viton / epdm / ptfe / nitrile liner, lever / gearbox / electric / pneumatic actuation. Lloyds BV DNV certification facilities available on request.

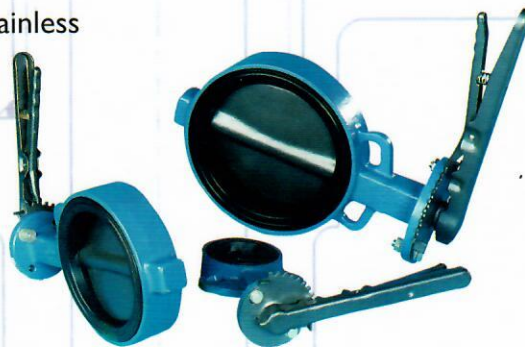

- AIR RELEASE VALVES
- BALL VALVES
- BALL FLOAT VALVES
- BELLOWS SEALED VALVES
- BUTTERFLY VALVES
- CONTROL VALVES
- CHECK VALVES
- DIAPHRAGM VALVES
- ELECTRIC ACTUATORS
- FOOT VALVES
- GATE VALVES
- GAS REGULATORS
- GLOBE VALVES
- HYDRANTS
- KNIFE GATE VALVES
- MARINE VALVES
- MUD BOXES
- NEEDLE VALVES
- PARALLEL SLIDE VALVES
- PLUGLESS TAPS
- PNEUMATIC ACTUATION
- PRESSURE GAUGES
- REDUCING VALVES
- SAFETY VALVES
- SURPLUS VALVES
- SIGHT GLASSES
- STRAINERS
- STORM VALVES
- TREACLE TAPS
- WAFER VALVES
- VACUUM/PRESSURE & VACUUM VALVES
- VALVE OVERHAUL & REPAIR

Flowstar (U.K.) Limited stockists of a wide range of pressure control equipment. For any specific requirements please contact our sales department and we will be pleased to offer help and technical advice on:

TELEPHONE: 01482 210484 FAX: 01482 586064
 Email: sales@flowstar.co.uk

flowstar

Flowstar (U.K.) Limited,

Unit 1, Gillett Street, Hull, East Yorkshire HU3 4JA