

HUCK's original Grade 8 fastening system, the HP8® PowerBolt™, provides an easy-to-use system that delivers a permanent, vibration resistant clamp. These fasteners, available in diameters ranging from 1/2" to 3/4", offer fast, tamper-resistant installation, with only a visual inspection required.

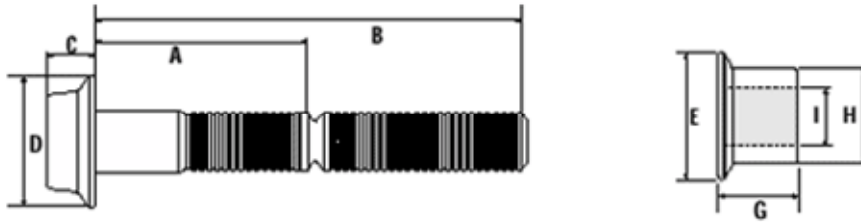

Fastener Dimensions



1/2" Round Head (DT16)

	Grip No.	A	B
C= .307	8	1.625	3.550
D= 1.07	12	1.875	3.800
G= .75	16	2.125	4.050
H= .812	20	2.375	4.300
I= .519	28	2.875	4.80
	36	3.375	5.300
	44	3.875	5.800
	52	4.375	6.300
	60	4.875	6.800

5/8" Round Head (DT20)

C= .498
D= 1.330
G= .922
H= 1.009
I= .645

Grip No.	A	B
8	1.820	4.038
12	2.070	4.288
16	2.320	4.538
20	2.570	4.788
28	3.070	5.288
36	3.570	5.788
44	4.070	6.288
52	4.570	6.788
60	5.070	7.288
88	6.820	9.038

3/4" Round Head (DT24)

C= .60
D= 1.59
G= 1.107
H= 1.213
I= .780

Grip No.	A	B
8	2.000	4.640
12	2.250	4.890
16	2.500	5.140
20	2.750	5.390
28	3.250	5.890
32	3.500	6.140
36	3.750	6.390
44	4.250	6.890
52	4.750	7.390
60	5.250	7.890

Inspection Data

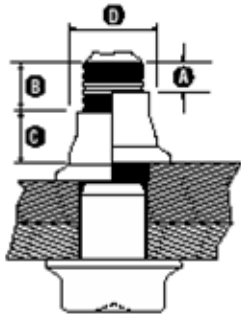

ROUND HEAD INCH SERIES (")

DIAMETER	A (MIN)	B (MAX)	C (MIN)	D (MAX)
DT16	.10	.65	.56	.760
DT20	.12	.67	.73	.945
DT24	.12	.67	.86	1.132

Installation Tooling

Dia.	Installation Tool	Nose Assembly	Type	Use
1/2	FE5901	99-5300	Hydraulic	Production
	5901	99-5300	Hydraulic	Production
5/8	585	99-5301	Hydraulic	Production
	3/4	585	99-5303	Hydraulic

Part Number Identification

HP8 F DT 16 16

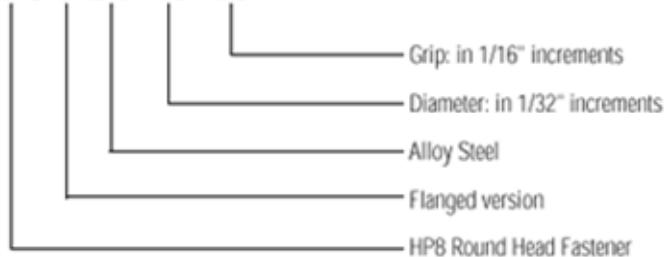

Installation Sequence

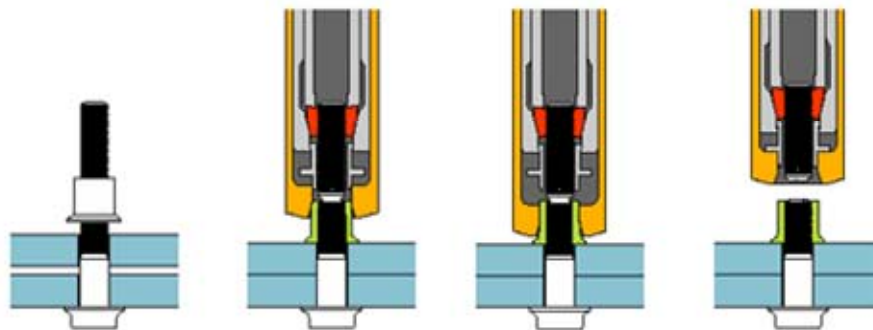

[Click Here to view animation of installation sequence](#)