

**Model:**

- 13024 – (0-4,500 RPM) includes 13016 1/2"dia. arbor.
- 13025 – (0-3,400 RPM) includes 13016 1/2"dia. arbor.
- 13026 – (0-3,400 RPM) includes 13017 5/8"dia. arbor.
- 13027 – (0-3,400 RPM) includes 13014 14 mm arbor.
- 13028 – (0-3,400 RPM) includes 13015 5/8"-11 thread arbor for optional 94472 Pneumatic Wheel.
- 13029 – (0-4,500 RPM) includes 13071 multi-purpose arbor.\*
- 13030 – (0-3,400 RPM) includes 13071 multi-purpose arbor.\*
- 13050 – (0-950 RPM) includes 13071 multi-purpose arbor.\*

Parts Page Reorder No. PD94•06

Effective February, 1994

Supersedes PD91•25

# Dynastraight®

## Machine and Air Motor Parts

### ! WARNING

Always operate, inspect and maintain this tool in accordance with the Safety Code for portable air tools (ANSI B186.1) and any other applicable safety codes and regulations. Please refer to Dynabrade's Warning/Safety Operating Instructions for more complete safety information.

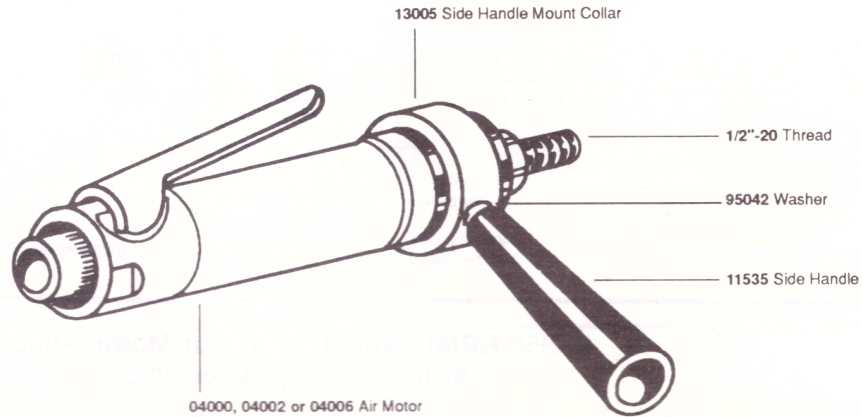

\*Note: For models 13029, 13030 and 13050, please refer to PD90•30 multi-purpose arbor instruction manual for proper mounting arrangements.

### (0-3,400 RPM) Dynastraight® Air Motor – 04000 Standard Motor on Models 13025, 13026, 13027, 13028 and 13030.

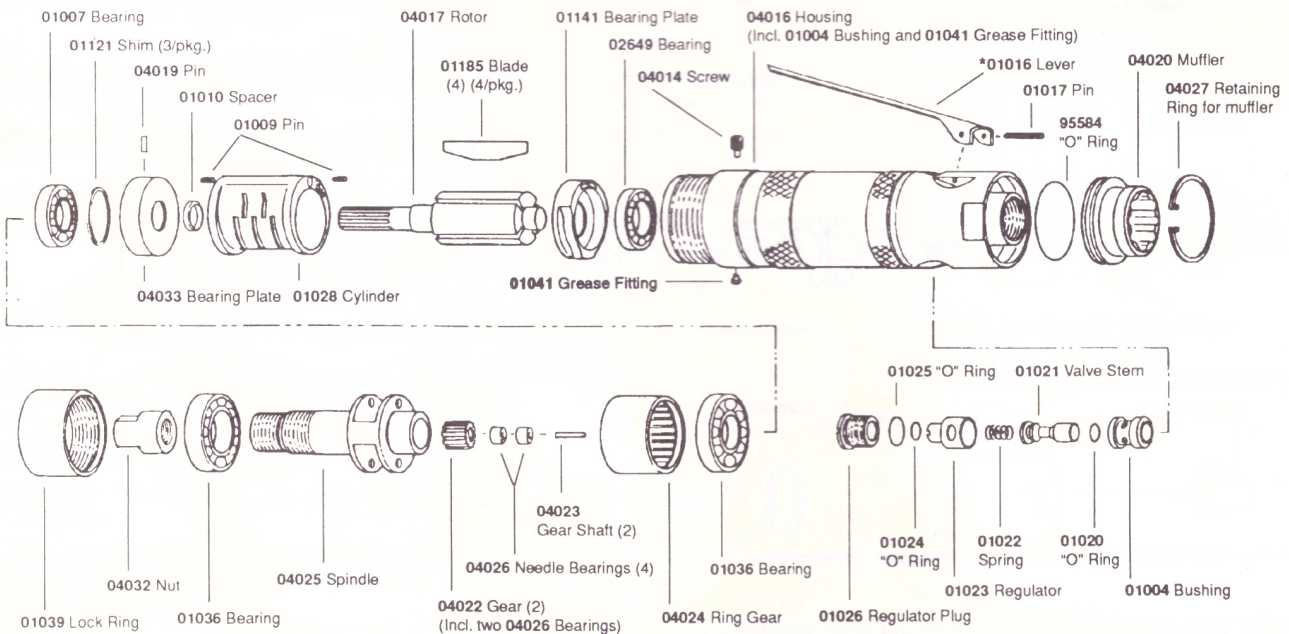

\*01089 Safety Lock Lever Assembly available on all models.

**(0-4,500 RPM) Dynastraight™ Air Motor – 04002**  
**Standard Motor on Models 13024 and 13029.**

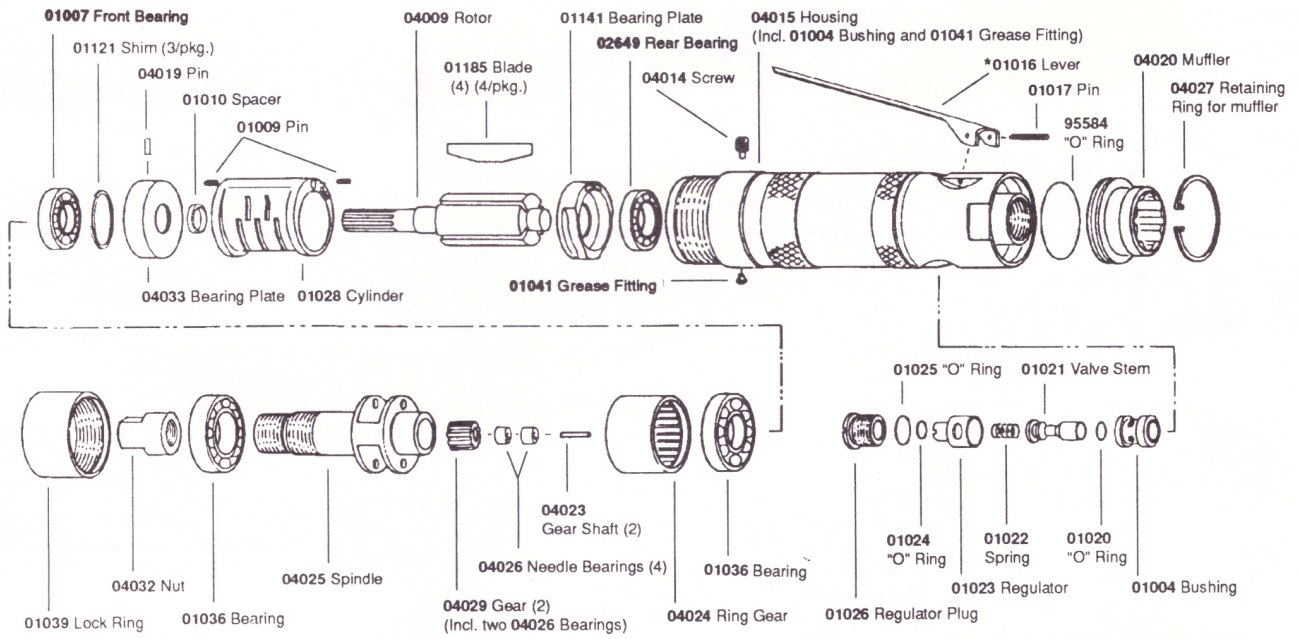

**(0-950 RPM) Dynastraight® Air Motor – 04006**  
**Standard Motor on Model 13050.**

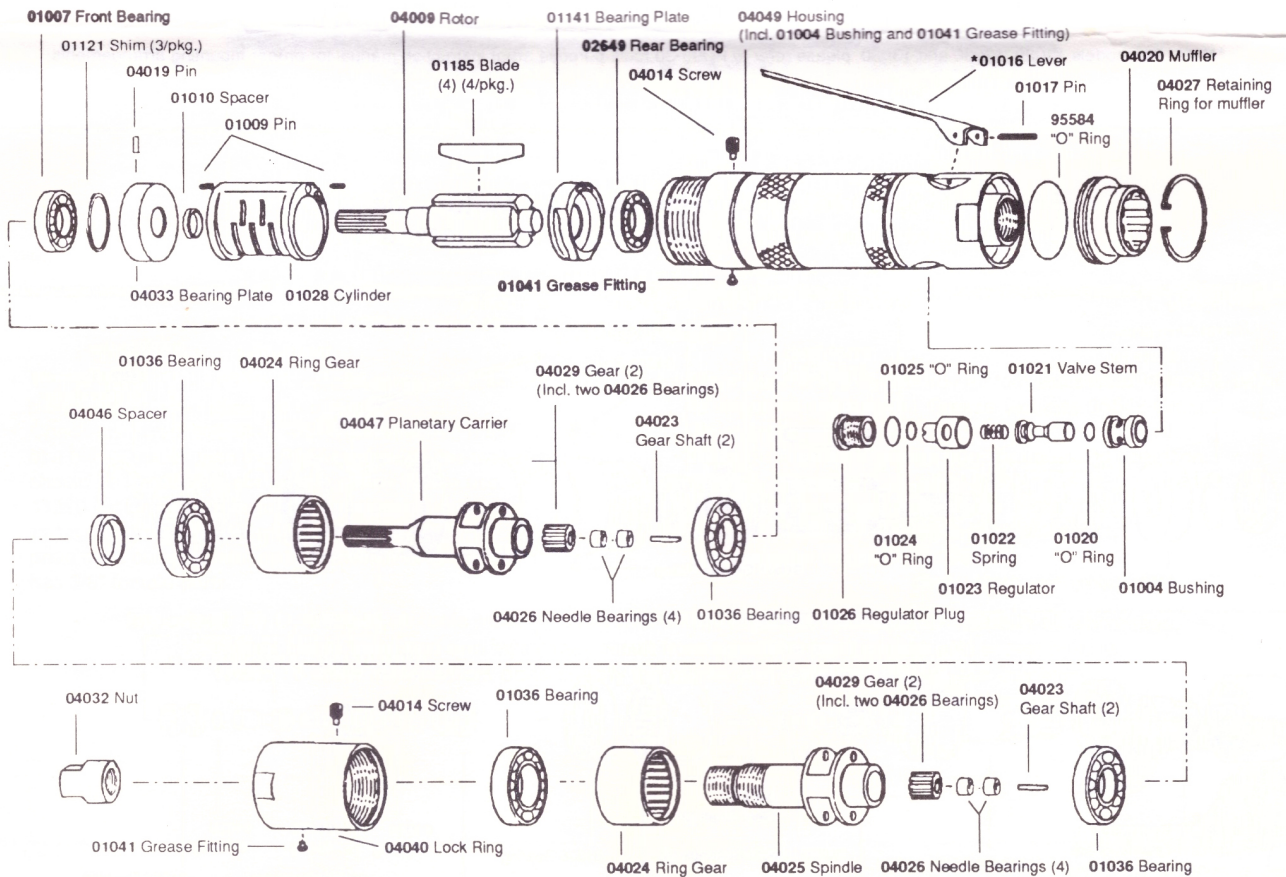

\*01089 Safety Lock Lever Assembly available on all models.

Note: When reassembling motors add a drop of Loctite® 271 or equivalent to threads of motor housing.

Loctite is a registered trademark of Loctite Corporation.

**INTERCHANGEABLE WHEEL ARBOR ASSEMBLIES**

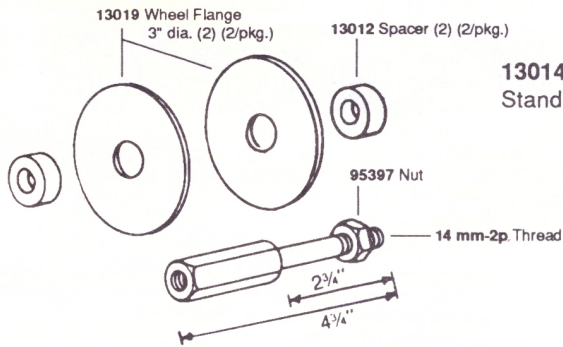

**13014 – 14 mm Diameter –**  
Standard wheel arbor assembly on model 13027 Dynastraight®.

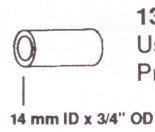

**13038 – Optional Sleeve –**  
Used to adapt 94473  
Pneumatic Wheel to this arbor.

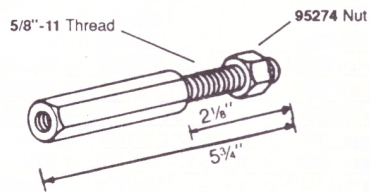

**13015 – 5/8"-11 Thread –**  
For mounting 94472 5" dia. x3-1/2" wide Pneumatic Wheel.  
Standard wheel arbor assembly on model 13028 Dynastraight®.

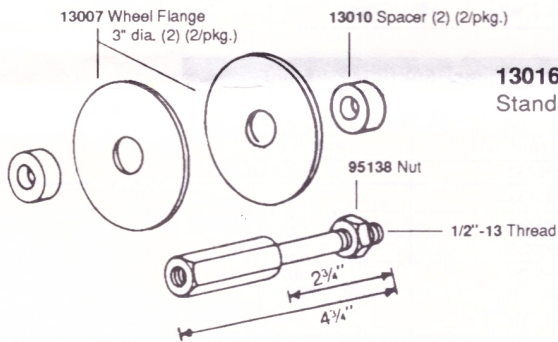

**13016 – 1/2" Diameter –**  
Standard wheel arbor assembly on model 13024 and 13025 Dynastraight®.

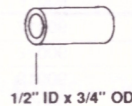

**13039 – Optional Sleeve –**  
Used to adapt 94473  
Pneumatic Wheel to this arbor.

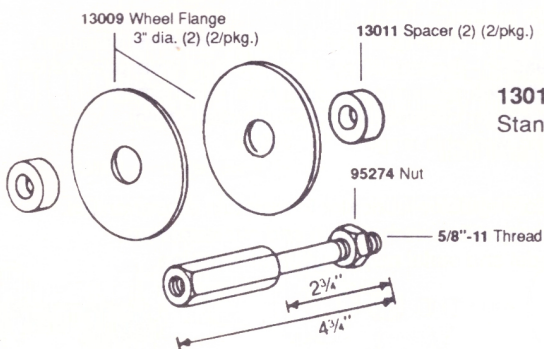

**13017 – 5/8" Diameter –**  
Standard wheel arbor assembly on model 13026 Dynastraight®.

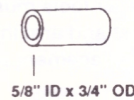

**13040 – Optional Sleeve –**  
Used to adapt 94473  
Pneumatic Wheel to this arbor.

**SEE REVERSE SIDE FOR ABRASIVE AND IMPORTANT SAFETY INFORMATION.**

## Mounting Accessories

Non-Woven Nylon Discs 5" Diameter x 1/2" Wide x 1/2"/Unit = 20 Discs	
Grit	Part Number
Coarse	90883
6" Diameter x 1/2" Wide x 1/2"/Unit = 20 Discs	
Grit	Part Number
Coarse	90886

Available Wheel Guards  
**13032** – for wheels up to 8" D x 2" W.  
**13033** – for pneumatic wheels up to 5" dia.

Non-Woven Nylon Wheels 6" Diameter x 2" Wide/Unit = 2 Wheels 6" Diameter x 2" Wide/Unit = 4 Wheels		
Grit	6" Dia. x 2" W x 1" Part Number	6" Dia. x 1" W x 1" Part Number
Super Fine	–	–
Very Fine	–	–
Medium	90865	90866
Coarse	–	–

Note: Wheels include 1/2" and 5/8" diameter flange inserts.

Non-Woven Nylon/Unit = 10 Belts			
Grit	2-3/4" W x 15-1/2" L Part No.	3" W x 10-11/16" L Part No.	3-1/2" W x 15-1/2" L Part No.
Super Fine	90013	90219	90014
Very Fine	90021	90237	90281
Medium	90022	90238	90282
Coarse	90023	90239	90283

Dynacushion® Pneumatic Wheels/Unit = 10 Wheels					
Model Number	Wheel Size	Arbor Hole	Belt Size	Max. RPM	P/N Rubber Wheel Only
94469	5" dia. x 3-1/2" wide	1/2" Bore	3-1/2" W x 15-1/2" L	3,500	94481
94470	5" dia. x 3-1/2" wide	1/2"-13 Thread	3-1/2" W x 15-1/2" L	3,500	94481
94471	5" dia. x 3-1/2" wide	5/8" Bore	3-1/2" W x 15-1/2" L	3,500	94481
94472	5" dia. x 3-1/2" wide	5/8"-11 Thread	3-1/2" W x 15-1/2" L	3,500	94481
94473	5" dia. x 3-1/2" wide	3/4" Bore	3-1/2" W x 15-1/2" L	3,500	94481
94490	5" dia. x 2-3/4" wide	1/2" Bore	2-3/4" W x 15-1/2" L	3,500	94481
94491	5" dia. x 2-3/4" wide	1/2"-13 Thread	2-3/4" W x 15-1/2" L	3,500	94482
94492	5" dia. x 2-3/4" wide	5/8"-11 Thread	2-3/4" W x 15-1/2" L	3,500	94482
94493	5" dia. x 2-3/4" wide	3/4" Bore	2-3/4" W x 15-1/2" L	3,500	94482
94494	5" dia. x 2-3/4" wide	5/8" Bore	2-3/4" W x 15-1/2" L	3,500	94482
94503	3-1/4" dia. x 3" wide	3/8" Bore	2-3/4" W x 15-1/2" L	7,000	94500
94504	3-1/4" dia. x 3" wide	3/8"-24 Thread	2-3/4" W x 15-1/2" L	7,000	94500
94505	3-1/4" dia. x 3" wide	1/2" Bore	3" W x 10-11/16" L	7,000	94500
94506	3-1/4" dia. x 3" wide	1/2"-13 Thread	3" W x 10-11/16" L	7,000	94500
94507	3-1/4" dia. x 3" wide	5/8" Bore	3" W x 10-11/16" L	7,000	94500
94508	3-1/4" dia. x 3" wide	5/8"-11 Thread	3" W x 10-11/16" L	7,000	94500

Abrasive Belts For Dynacushion® – Aluminum Oxide/Unit = 50 Belts			
Grit	2-3/4" W x 15-1/2" L Part Numbers	3" W x 10-11/16" L Part Numbers	3-1/2" W x 15-1/2" L Part Numbers
36	90016	90232	90271
60	90017	90233	90272
80	90018	90234	90273
100	90019	90235	90274
120	90020	90236	90275
180	90026	90268	90277

### IMPORTANT

- Tool RPM rating must never exceed abrasive/accessory RPM rating, regardless of the tool's capacity.
- Check tool speed regularly with a tachometer. If tool is operating at a higher speed than the RPM marked on the tool, the tool should be serviced to correct the cause before use.
- 11299 Air Line Filter-Regulator-Lubricator – Provides water contaminants and micro-mist lubrication of pneumatic components; operates 28 CFM @ 90 PSI; has 3/8" female ports.
- Gear case of this Dynabrade air tool should be lubricated every 50 hours by using 95541 Grease Gun and 95542 Grease. To reorder:
  - 95541 – Push-type grease gun; for one-hand operation.
  - 95542 – Grease (10 oz. tube; 283.5 g.) Multi-purpose for all types of bearings, cams, gears. High film strength; excellent resistance to water, steam, etc. workable range 0° F to 300° F.

**Important:** All Dynabrade air tools must be used with a filter-regulator-lubricator to maintain all warranties.

**Warning:** Hand, wrist and arm injury may result from repetitive work motion and overexposure.

**Note:** To order replacement parts specify the model and serial number of your machine.



**DYNABRADE, INC.,** 8989 Sheridan Drive • Clarence, New York 14031-1490 • Phone: (716) 631-0100 • Fax: 716-631-2073

**DYNABRADE EUROPE s.a.r.l.,** Zone Artisanale • L-5485 Wormeldange—Haut, Luxembourg • Telephone: 352 76 84 94 • Fax: 352 76 84 95

© DYNABRADE, INC., 1991

PRINTED IN USA.



## Disassembly/Assembly Instructions Dynastraight®

Please refer to parts page for part identification.

A complete tune-up kit, part number **95604**, is available which includes assorted parts to help maintain motor in tip-top shape.

### To Disassemble:

1. Remove wheel arbor, **13005** Collar and **11535** Side Handle.
2. Secure machine housing in vise. (**Important:** Use flats on bottom of housing to prevent damage).
3. Remove **01039/04040** Lock Ring.
4. Remove **04014** Lock Screw from housing.
5. Pull **04024/04047** Planetary Carrier from housing.
  - 5a.) On 950 RPM models the **04025** Planetary Carrier is located inside the **04040** Lock Ring. Remove **04014** Set Screw and pull out carrier.
6. Remove housing from vise. Tap front of housing against a soft wooden surface. Motor assembly should drop out of housing.

### Motor Disassembly:

1. Press rotor from **02649** Bearing and **01141** Bearing Plate.
2. Press **02649** Rear Bearing from **01141** Bearing Plate.
3. Remove cylinder and **01185** Blades (4) from rotor.
4. Press rotor from **01007** Bearing and **04033** Bearing Plate.
5. Press **01007** Front Bearing from **04033** Bearing Plate.
6. Remove **01010** Spacer from rotor.

### Planetary Carrier Disassembly:

1. Press off **01036** Rear Bearing from Planetary Carrier.
2. Remove ring gear.
3. Remove gears.
4. Secure carrier in padded vise.
5. Remove **04032** Nut from **04025** Carrier.
  - 5a.) On 950 RPM Model, remove **04046** Spacer from **04047** Carrier also.
6. Press off **01036** Front Bearing.

### Valve Stem Disassembly:

1. Remove **01026** Regulator Plug. All parts should easily slide out of housing.

### Reassembly:

**Important:** Be certain all parts are cleaned, properly greased and in good repair before reassembly.

### Motor Reassembly:

1. Press **01007** Front Bearing into **04033** Bearing Plate (**Note:** Shimming may be required in upcoming steps).
2. Install **01010** Spacer on rotor.
3. Press bearing and bearing plate onto rotor and spacer.
4. Use a .001" thick feeler gauge to set clearance between **04033** Bearing Plate and rotor.
  - 4a.) If shimming is required, use the **01121** Shim Pack accordingly to shim between the **01007** Front Bearing and bearing plate to obtain a .001" clearance between the bearing plate and rotor.
5. Install **01185** Blades (4) onto rotor. (**Note:** Blades should be lubricated with Dynabrade Air Lube P/N **95842** or equivalent before installation).
6. Install **01028** Cylinder over rotor and onto **04033** Bearing Plate. Be sure to line up **01009** Pin in **04033** Bearing Plate with hole in cylinder. (**Note:** Air inlet holes in cylinder should face away from **04033** Bearing plate).
7. Press **02649** Rear Bearing into **01141** Bearing Plate.
8. Press bearing and bearing plate onto rotor. Be sure **01009** Pin in **01141** Bearing Plate lines up with hole in cylinder. (**Important:** The fit must be snug between bearing plates and cylinder. If too tight, rotor will not turn freely. Rotor must then be lightly tapped at short end so it will turn freely while still maintaining a snug fit. A loose fit will not achieve the proper pre-load of the motor bearings).

(continued on reverse side)

1. Press **01036** Front Bearing onto carrier.
2. Place carrier in padded vise (**04025** only).
3. Apply a slight amount of #271 Loctite® (or equivalent) to first few threads of carriers.
4. Install **04032** Nut and torque to 260 inch lbs.
5. Remove from vise and install gears (grease before installation).
6. Slip on ring gear. (**Important:** Notches in ring gear must face away from threaded end of carrier).
7. Press on **01036** Rear Bearing.

### Valve Stem Reassembly:

1. Reassemble valve stem parts in proper sequence as diagramed on parts page.
2. Insert into housing and reinstall **01026** Regulator Plug. **Important:** Make sure that the hole in **01023** Regulator Lines up with the air inlet. This will ensure maximum RPM.

### To Reassemble:

1. Place housing in vise. Use flats on housing to prevent damage.
2. Install motor assembly into housing. Make sure **04019** Line-Up Pin on **04033** Bearing Plate fits into groove inside housing.
3. Install **04025** Carrier Assembly (**04047** Carrier Assembly in 950 RPM Model) into housing. Line up notches in ring gear with lock screw hole and grease fitting in housing. Install and tighten **04014** Lock Screw to secure carrier assembly.  
3a.) On 950 RPM Model, install **04025** Carrier Assembly into **04040** Lock Ring. Make sure notches in ring gear line-up with lock screw hole and grease fitting on lock ring. Install and tighten **04014** Lock Screw to secure carrier assembly in lock ring.
4. Apply a small amount of #271 Loctite® (or equivalent) to threads of housing.
5. Install **01039/04040** Lock Ring onto housing (torque to 345 inch lbs.).
6. Grease gears through grease fittings by using Dynabrade's **95542** Grease Gun and Gear Grease (or equivalent).
7. Lubricate motor by squirting 2 or 3 shots of Dynabrade Air Lube P/N **95842** (or equivalent) into air inlet.
8. Complete reassembly by remounting wheel arbor, **13005** Collar and **11535** Side handle.

### Important

The regular maintenance of any air tool will contribute to greater efficiency of tool and will prolong tool life. The failure of quality pneumatic air motors can most often be traced to an unclean air supply or the lack of lubrication. Air pressure easily forces dirt or water contained in the air supply into motor bearings causing early failure. It often scores the cylinder walls and the rotor blades resulting in limited efficiency and power. Frequent drainage of water traps in air lines is recommended. Each tool on each drop should also be equipped with a secondary air processing unit. This consists of an in-line Filter-Regulator-Lubricator. All Dynabrade air tools must be used with a Filter-Regulator-Lubricator to maintain all warranties. Our warranty obligation is contingent upon proper use of our tools and cannot apply to equipment which has been subject to misuse such as unclean air, wet air or a lack of lubrication during the use of the tool.

**Notice:** Manufacturer's warranty is void if tool is disassembled before warranty expires.

Loctite is a registered trademark of the Loctite Corp.