

# VL500-35

---

Model:

VL500 - 35B - Nilfisk

VL500 - 35E - Nilfisk

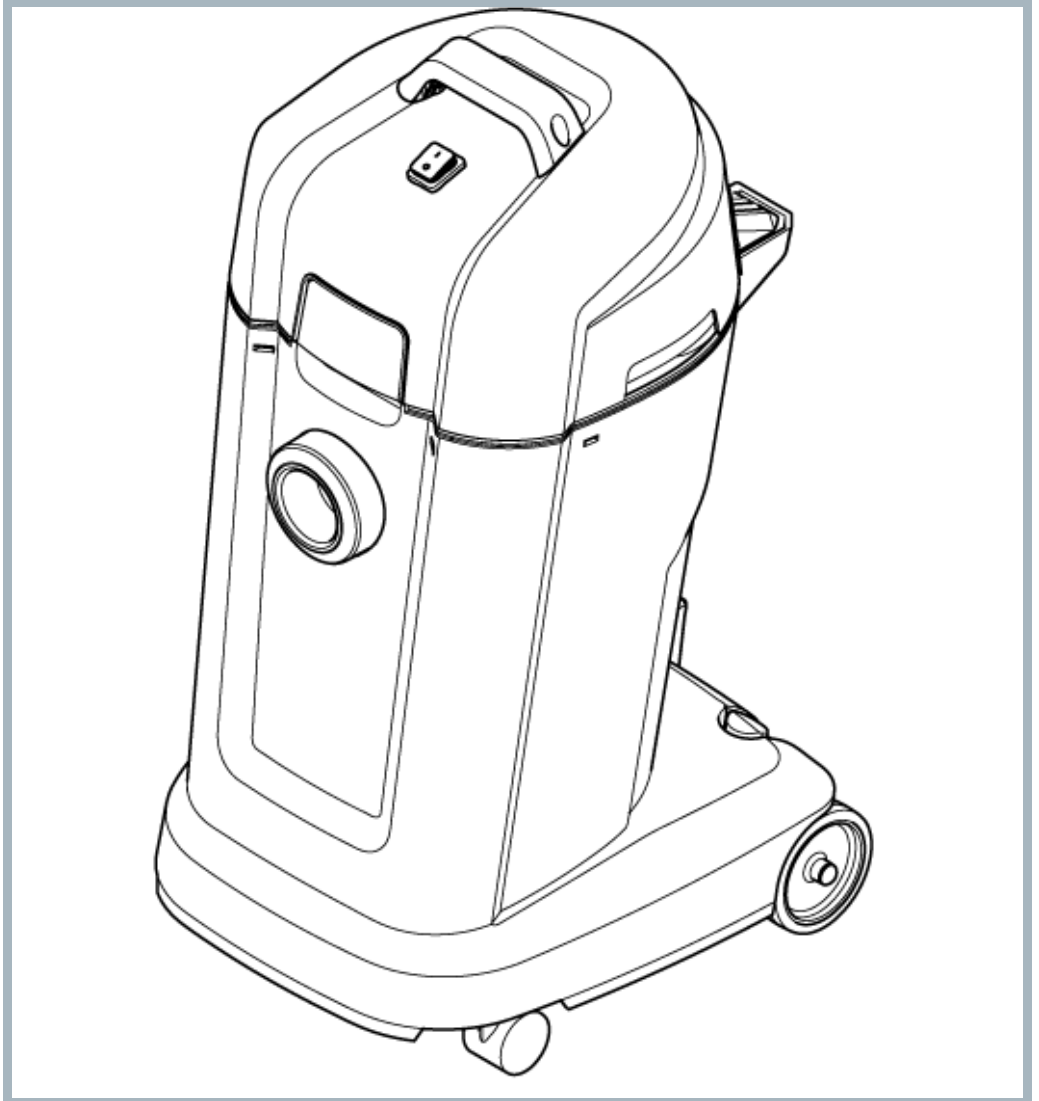

Part List US-English

12-11-2014

# Table of Contents

VL500-35

<b>Top 35</b>	<b>3</b>
<b>Container 35 BSF, BDF, EDF</b>	<b>5</b>
<b>Filters and bags 35</b>	<b>7</b>
<b>Accessories 35</b>	<b>9</b>
<b>Recommended spare parts 35</b>	<b>11</b>

# Top 35

VL500-35

12-11-2014

Part List ID  
VL50002

3

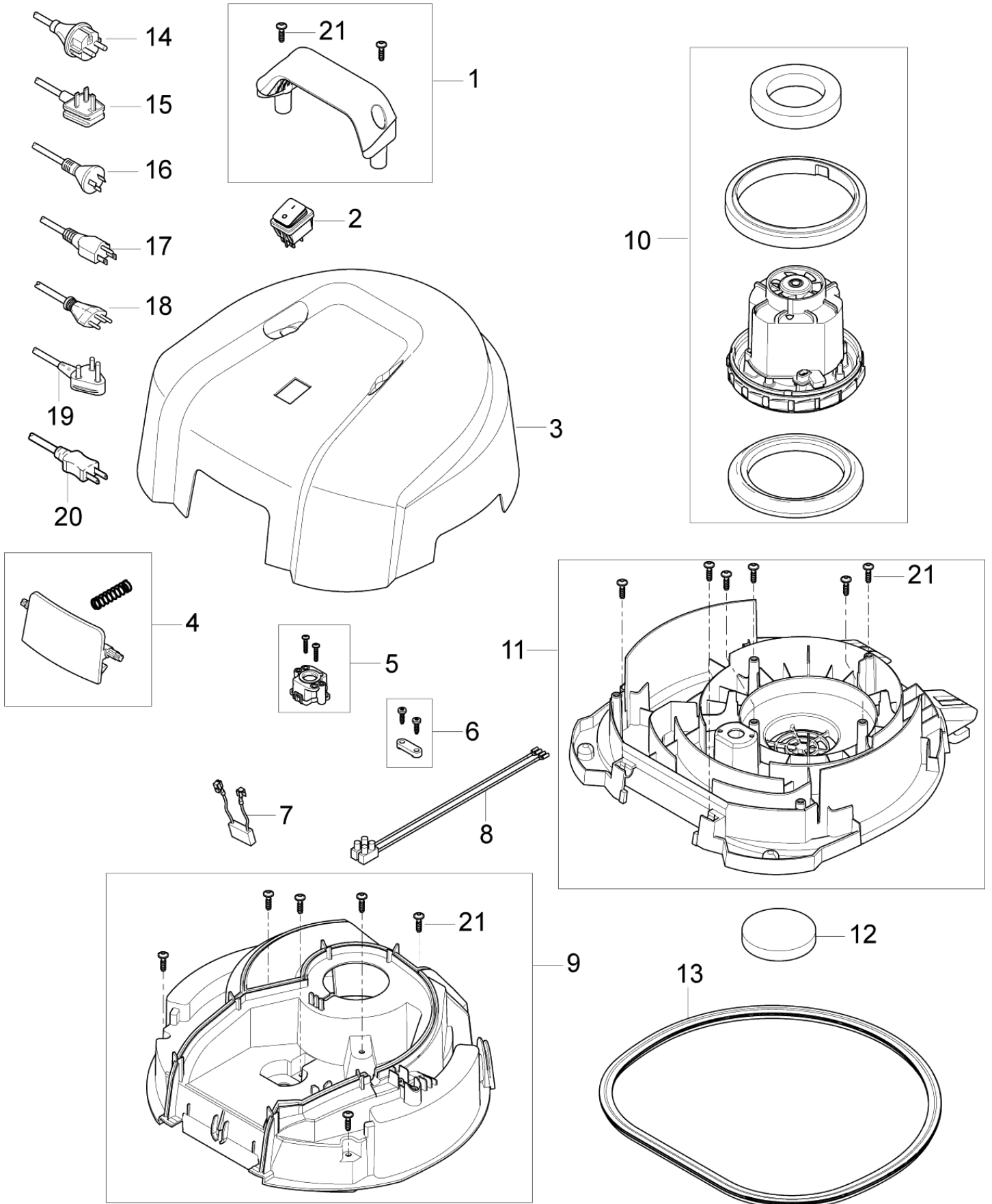

# Top 35

## VL500-35

12-11-2014

Part List ID  
VL50002

4

Pos	Part no.	Qty	Description
0	107410810	1	PACKAGING VL500/MAXXI 35 - KIT
01	107407233	1	HANDLE F. 35L BIN VL500
02	107404540	1	SWITCH 0-1 DOUBLE POLE SET
03	107407305	1	HOOD 35L VL500
04	107407235	1	CLAMP F. 75-55-35 L BIN VL500
05	107407237	1	VACUUM VALVE CPL.
06	140 6560 500	1	ANTI STRAIN CLIP
07	48338	1	ANTI-INTERFERENCE CAPACITOR
08	140 7042 500	1	WIRE INTERNAL FOR GWD 300
09	107407238	1	CLAMPINGPLATE 35L
10	302003384	1	MOTOR KIT 1200W 230V
10	302003388	1	MOTOR KIT 1000W 120V
11	107407239	1	BASEPLATE 35L 1 MOTOR VL500
12	140 8682 500	1	MOTOR FILTER
13	107407241	1	GASKET F. BASEPLATE 35L
14	12222501	1	CORD SET EU L 10M
15	12222503	1	CORD SET UK L 10M
16	12222506	1	CORD SET AU/NZ L 10M
17	107401614	1	CORD SET US/TW 3C 15.5M YELLOW
18	12222507	1	CORD SET CH L 10M
19	107407242	1	POWER CORD H05VV-F 2X1.00 SABS 164-1 16A ZA
20	140 6702 500	1	CORD SET JP 15.5M
21	302003704	8	SCREW EJOT DELTA PT50X18WN5451

# Container 35 BSF, BDF, EDF

VL500-35

12-11-2014

Part List ID  
VL50008

5

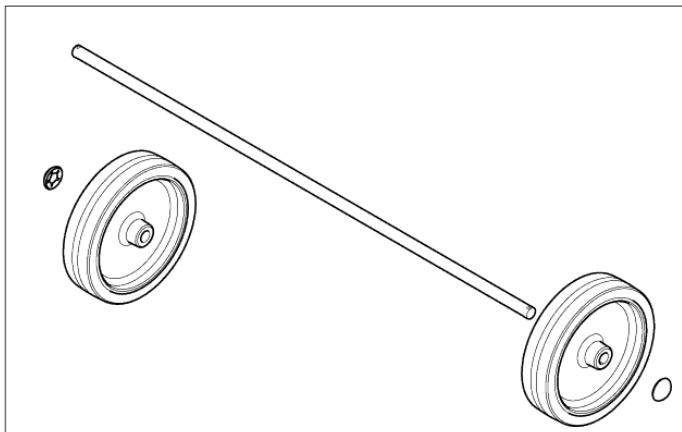

2

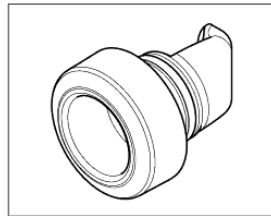

3

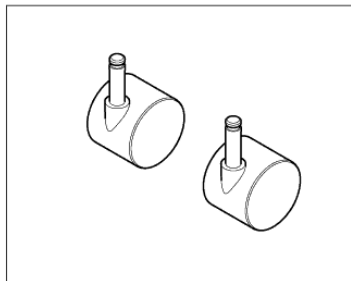

4

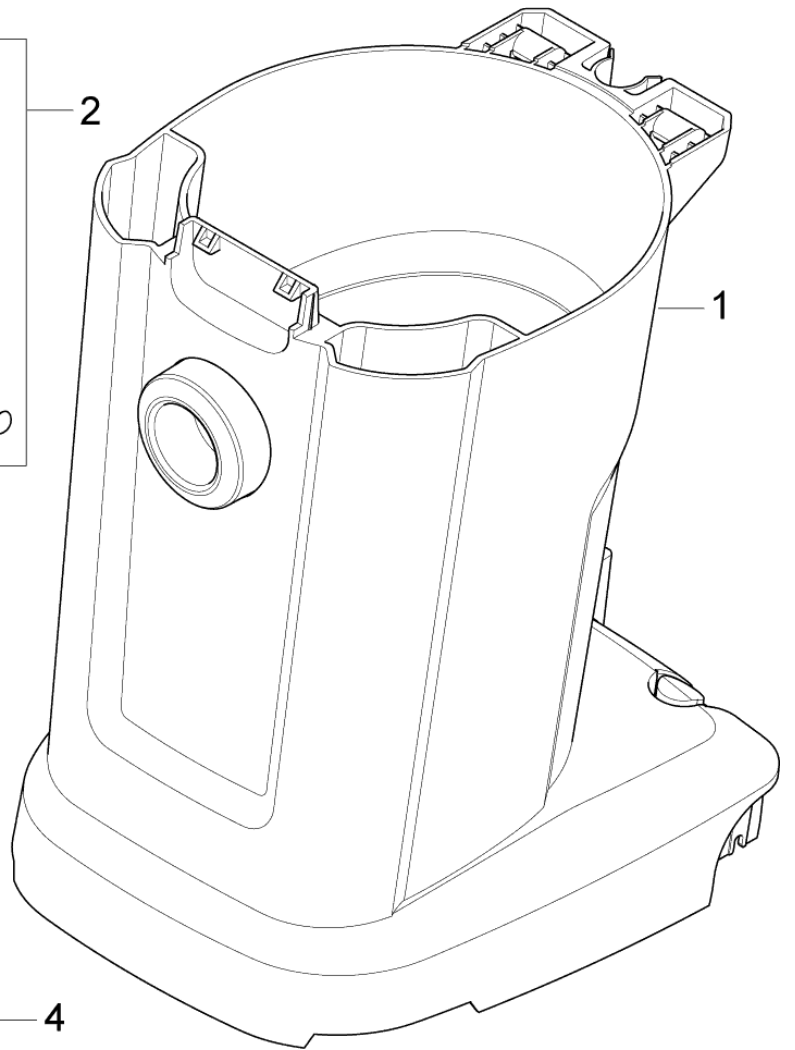

1

# Container 35 BSF, BDF, EDF

VL500-35

12-11-2014

Part List ID  
VL50008

6

Pos	Part no.	Qty	Description
1	107407256	1	CONTAINER WITH TROLLEY 35L VL500
2	140 8446 600	1	WHEEL REAR 2 PCS
3	107407258	1	INLET ROUND VL500
4	140 6422 500	1	WHEELS LINK 50MM

# Filters and bags 35

VL500-35

12-11-2014

Part List ID VL50020

7

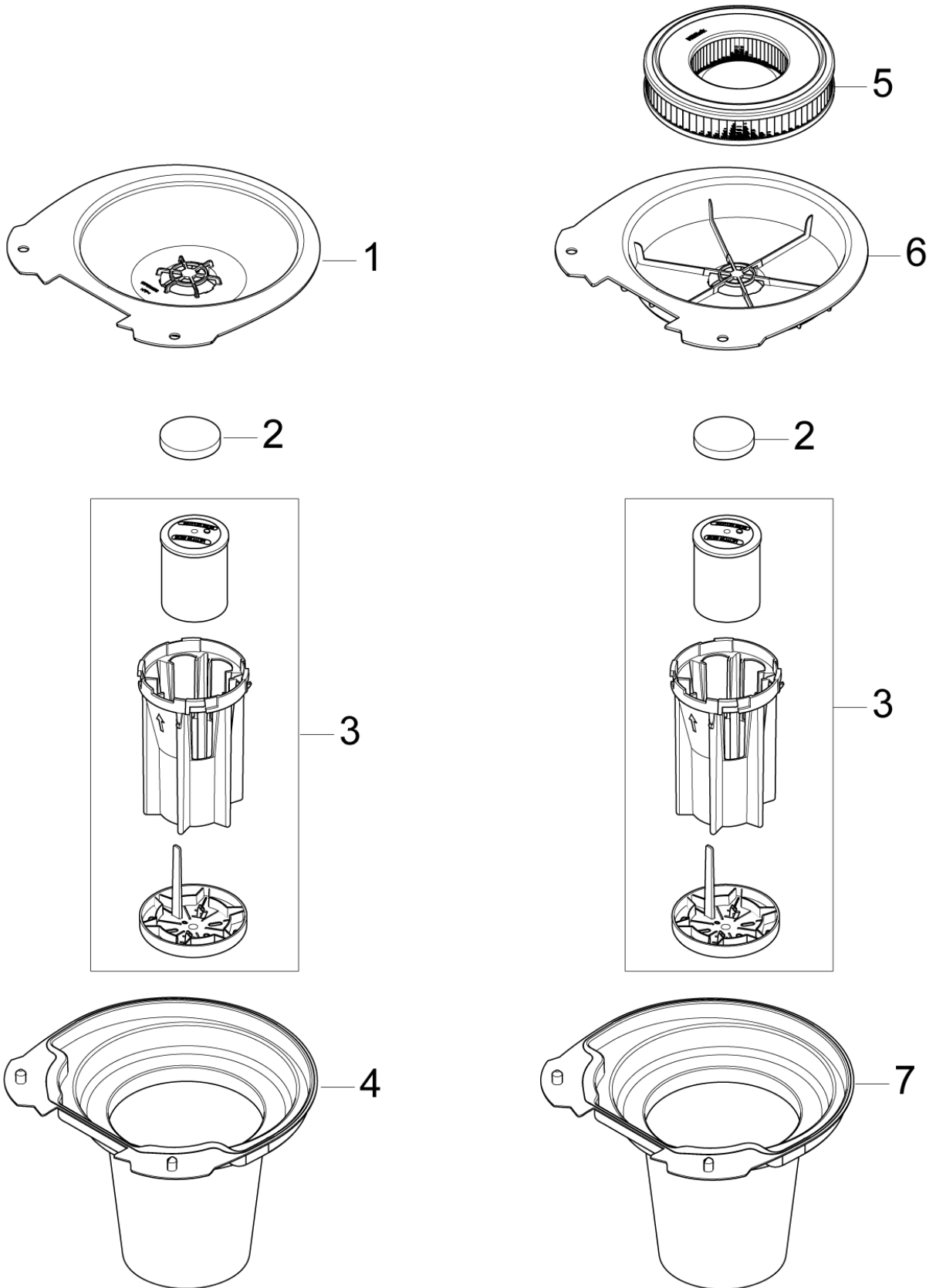

# Filters and bags 35

VL500-35

12-11-2014

Part List ID VL50020

8

Pos	Part no.	Qty	Description	
1	107407295	1	FLOATER ADAPTER 35L	BSF
2	140 8682 500	1	MOTOR FILTER	
3	140 8680 500	1	FLOAT BASKET	
4	107407296	1	SACK FILTER	BSF
5	107407297	1	CARTRIDGE FILTER	BDF, EDF
6	107407298	1	DRY FILTER BOX 35L	BDF, EDF
7	107407299	1	WET FILTER	BDF, EDF



# Accessories 35

VL500-35

12-11-2014

Part List ID  
VL5003512

9



# Accessories 35

VL500-35

12-11-2014

Part List ID  
VL5003512

10

Pos	Part no.	Qty	Description
1	302004004	1	FLEECE FILTER BAG 5 PCS ATTIX 40/50
2	107407308	1	HOSE D32 1.9M CPL
3	107407310	1	FLOOR NOZZLE D32 RUBBER STRIP
3	107407311	1	FLOOR NOZZLE D32 BRUSH
4	107407309	2	EXTENSION TUBE D32 - SS
5	107407334	1	CREVICE NOZZLE D32
6	107407312	1	BRUSH NOZZLE D32
7	107408801	1	PUMP KIT - VL500 220/240V

# Recommended spare parts 35

VL500-35

12-11-2014

Part List ID  
VL5003526

11

No Drawing For Part List

# Recommended spare parts 35

VL500-35

12-11-2014

Part List ID  
VL5003526

12

Pos	Part no.	Qty	Description
	107404540	1	SWITCH 0-1 DOUBLE POLE SET
	107407235	1	CLAMP F. 75-55-35 L BIN VL500
	107407237	1	VACUUM VALVE CPL.
	107407258	1	INLET ROUND VL500
	107407293	1	EASY TILT 75L BIN LEFT-RIGHT
	107407295	1	FLOATER ADAPTER 35L
	107407296	1	SACK FILTER
	107407297	1	CARTRIDGE FILTER
	107407298	1	DRYFILTER BOX 35L
	107407299	1	WET FILTER
	12222501	1	CORD SET EU L 10M
	140 6422 500	1	WHEELS LINK 50MM
	140 8446 600	1	WHEEL REAR 2 PCS
	140 8680 500	1	FLOAT BASKET
	140 8682 500	1	MOTOR FILTER
	302003384	1	MOTOR KIT 1200W 230V
	302003388	1	MOTOR KIT 1000W 120V
	302003704	1	SCREW EJOT DELTA PT50X18WN5451
	48338	1	ANTI-INTERFERENCE CAPACITOR