



OPERATING & MAINTENANCE MANUAL



PULSAR 515 & 429 VACUUM CLEANERS

**Read Safety & Operating Instructions
Before Commencing Operation**

THESE INSTRUCTIONS MUST BE READ AND ADHERED TO BEFORE OPERATING THIS MACHINE.

INTRODUCTION

The Kerrick Pulsar 515 and Pulsar 429 dry vacuum cleaners are certified for vacuuming “H” class dust according to regulation the IEC 60335-2-69:2002 + A1:2004 + A2:2007 (3). They are also certified to the European Standards: IEC 60335-1:2001 + A1:2004 + A2:2006; IEC 62233 (2005); and EN 62233 (2008). Australian and New Zealand Standards: AS/NZS CISPR 14.1 (2003); AS/NZS CISPR 14.2 (2003); AS/NZS 61000-3-2 (2007); and AS/NZS 61000-3-3 (2006).

Your vacuum cleaner comes complete with a full range of accessories designed to make your cleaning task and easy one. Manufactured in Italy this is a high quality unit designed to pick up dust and small deposits.

This vacuum cleaner is ideal for use in construction, demolition and decontamination sites as well as hospitals, clean rooms, offices and restricted areas that require high filtration particularly when dealing with hazardous dusts such as asbestos, lead, silica, cadmium, ink/toner dust etc.

To get the best from your Kerrick machine we suggest you follow the operating and maintenance details contained in this document.

WARNINGS:

- Kerrick cannot be held responsible for any damage/injury caused to persons or property, because of the incorrect use of the machine, due to procedures being used which are not specified in this instruction manual.
- The operator of this vacuum must be authorized to use it and aware of the risks involved with vacuuming toxic substances.
- This user manual acts as a guideline, the vacuuming and disposal of hazardous substances must be carried out in keeping with the national and state laws in your area.

SAFETY MANAGEMENT PROCEDURES

These Instructions must be read and adhered to before operating this machine. Failure to do so may result in injury to the operator, nearby persons, or damage to property, or this machine.

- The packaging around the cleaner (plastic bags, clips, ties etc) pose a choking hazard and should be kept out of the reach of children and animals.
- Before use the operator must be trained on how to use this device, the substances it will be used to vacuum and the correct and safe methods of removing and disposing of collected materials.
- **THIS MACHINE MAY CONTAIN DUSTS HAZARDOUS TO YOUR HEALTH.** Emptying of the tank, removing filters and maintenance work must be carried out by authorized personnel wearing suitable protective clothing.

- For maintenance work suitable precautions must be taken in a clean room environment including decontamination before dismantling, a forced exhaust air ventilation system must be used in the room and staff must wear appropriate PPE.
- A trained person must carry out a technical check at least once a year which consists of, for example, of checking filters, searching for damage that effect the air-tightness/seal of the device and the correct functioning of the control mechanism.
- The filtering efficiency of the device must be checked at least once a year.
- All parts of the device must be deemed to be contaminated when they are removed from a 'danger' area and appropriate action must be taken to prevent dispersal of dust.
- When maintenance or repair operations are carried out, all contaminated elements which cannot be cleaned well e.g. filters, must be eliminated.
- Eliminated items, including the machine at the end of its life, must be disposed of in impenetrable bags conforming to the laws and regulations applicable for the disposal of such materials.
- Check the vacuum cleaner has not suffered any bumps or damage after each use. If damage has occurred stop use immediately and send machine for repair to an appropriately trained person with clean room facilities.
- Check that all safety measures are present and in good working order, each time before commencing use.
- This machine is not designed to be used by children or mentally disabled individuals and if used incorrectly can be harmful.
- The end of the suction hose / accessories must be kept away from your face and the faces of others at all times during operation as the suction created can cause damage to the eyes, ears and mouth in particular.
- This appliance is double insulated and for **DRY USE ONLY**. Do not use the machine to suck up liquids of any kind.
- Do not operate this machine without the full filtration system fitted.
- Do not use adapters or multiple sockets, without knowing the electrical input of each user.
- If any electrical extension is used, check that it corresponds to the absorbed power of the machine and that the connection of the plug with the socket is compliant and sealed.
- Take care of the electrical cable. It must be protected from water, tears and chemical agents. Do not repair the cable in case of tears, but replace it with a new one. The cable must be replaced by the manufacturer or its service agent or a similarly qualified person in order to avoid further hazard.
- **DO NOT** pull the cable to drag the machine into position or to remove the plug from socket.
- Pull the plug out only when the machine is switched off.
- **DO NOT** handle the plug with wet hands.
- Unplug cable before servicing machine.
- This machine is not suitable for areas protected against electrostatic discharges.
- Use only the accessories supplied with the appliance or those specified in the user manuals. Using other brushes could jeopardize safety.
- This vacuum cleaner should **NEVER** be immersed in water.
- Do not tamper with or modify this vacuum cleaner in anyway. Any such changes will void the warranty and exempt the manufacturer from any liability.

UNPACKING AND SETTING UP

Assembly details and information on how to carry out various cleaning operations are outlined below. Read safety and operating instructions before commencing operation. This vacuum cleaner is double insulated and designed for **DRY USE ONLY**. Do not use the machine to suck up liquids of any kind.

Before commencing use operators must ensure they are wearing the correct personal protective equipment and have taken appropriate measures to protect their safety, the safety of others and the surrounding environment.

A - Vacuum head / motor

B - Switch

B1 - Switch only for PULSAR 429

B2 - Bag full pilot light

E - HEPA filter cartridge

F - Hooks to secure vacuum motor head to tank

G - Suction inlet

S - Paper bag (optional)

H - Tank

L - Flexible hose

M - Tube

N - Adaptor

O - Wand

P - Round brush

L - Flat lance

R - Dust tool

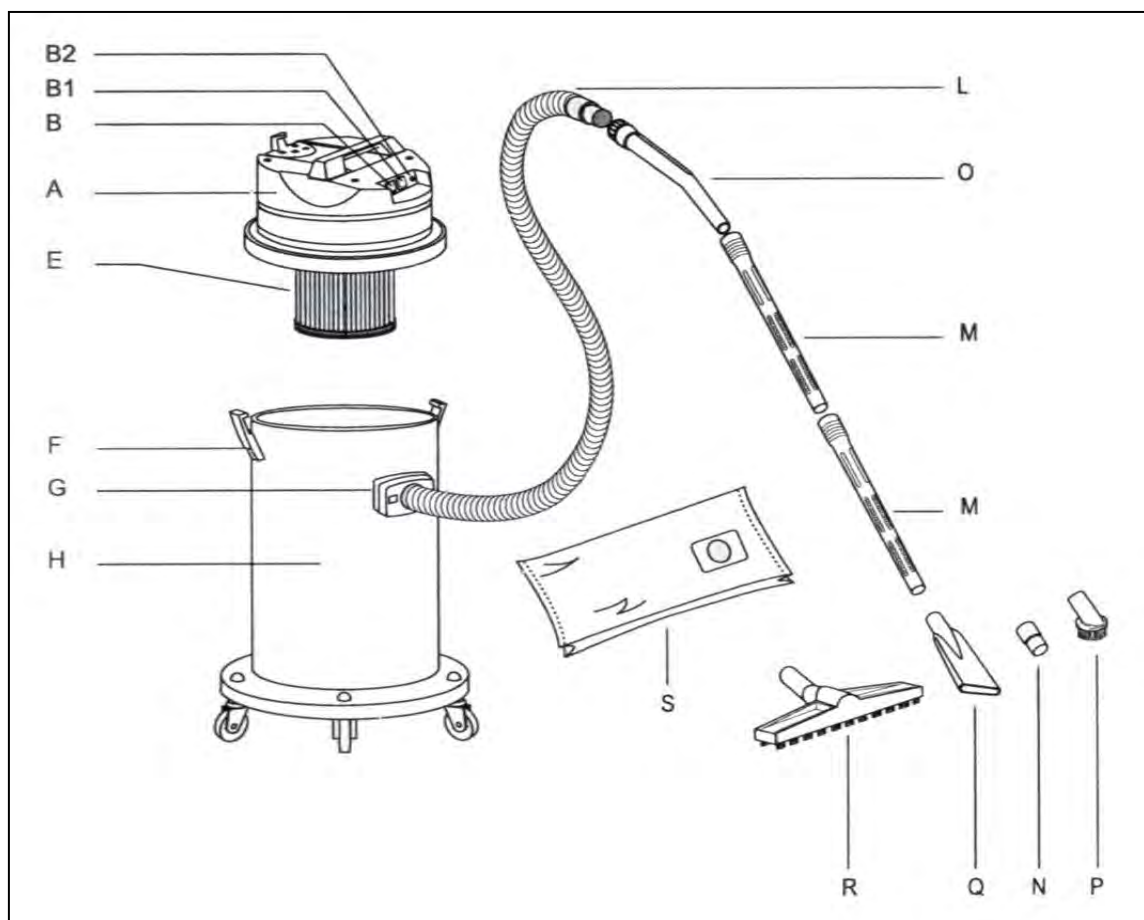

BEFORE EACH USE

- 1) Read the information about safe methods for collection, removal, disposal and decontamination.
- 2) Check for any signs of dust.
- 3) Ensure there is no damage to the vacuum cleaner and it is in good working order.
- 4) Ensure the filter is as per the manufacturer's specifications.
- 5) Ensure the latches are secure and the cords are not worn or frayed.

GENERAL ASSEMBLY

- 1) Lift the machine out of the box by gently angling the box and pulling the vacuum cleaner by its carry handle.
- 2) Unclip the two clips (F) on the side of the motor head (A) and lift the motor from the tank (H).
- 3) Ensure the HEPA filter (E) is locked into place.
- 4) If using a filter bag (S), ensure it is fitted over the deflector inlet inside the tank (H).
- 5) Place the motor head (A) back on top of the tank and clip it (F) into place.
- 6) Remove the plug from inlet (G).
- 7) Insert the flexible vacuum hose (L) into the tank inlet (G) and press until you hear a click as it locks into place.
- 8) Screw the top wand (O) into the flexi hose (L).
- 9) Fit the two piece extension wands (M) together and connect to the top wand (O).
- 10) Select the most suitable accessory for the job (N, P, Q or R) and connect it to the extension wand (M).
- 11) Unwind the electrical cable and insert the plug into an appropriate power socket with the correct electrical output.
- 12) Your machine is now ready for use, turn it on using the switch (B) and/or (B2) and vacuum as required.
- 13) Turn off using the same switch (B) and/or (B2).
- 14) Once vacuuming is complete and the machine is unplugged and turned off, place the vacuum, hose and tools into a 200 µm (minimum thickness) labeled polyethylene bag and seal it. Keep bag sealed until ready to clean down and decontaminate the unit in a clean room.

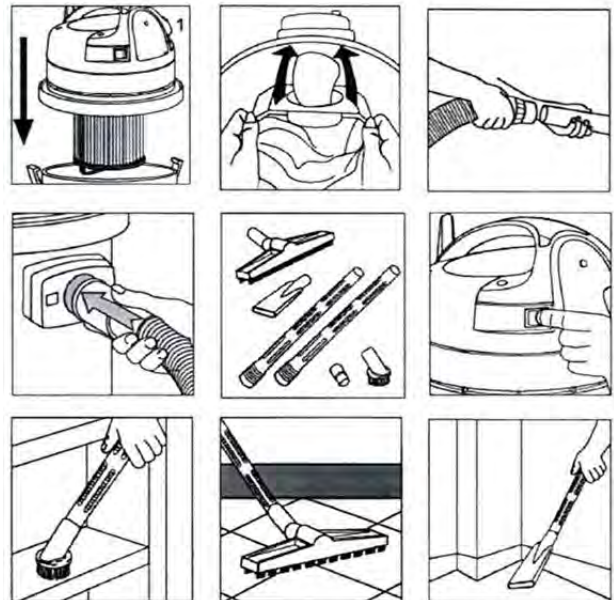

PERSONAL PROTECTIVE EQUIPMENT (PPE)

The dusts picked up by this vacuum cleaner could be toxic. We therefore suggest when using, emptying or disposing of vacuum cleaners that the following PPE be worn:

1. Half-face P1 or P2 respirator (disposable or cartridge)
2. Gloves
3. Disposable overalls with hood
4. Boot covers.

The advice above covers the minimum safety requirements, please take note of your national health and safety laws and put them into strict practice.



VACUUM CLEANER CLEANING

1. Clean the vacuum cleaner in an enclosed/isolated area.
2. After each use, decontaminate the outer casing and attachments with the vacuum, then with a wet wipe.
3. We recommended waiting a few minutes before opening the vacuum, to replace filters and bags, to allow any contaminated dusts to settle in the tank.
4. Remove the hose and replace the sealing cap over the hose opening.
5. Dispose of the contents of your vacuum cleaner in keeping with your national health and safety laws. We recommend as a minimum that waste is placed in a heavy duty, 200 µm (minimum thickness) polyethylene bag, labeled with an appropriate toxicity warning. Store hose attachments in a 200 µm (minimum thickness) labeled polyethylene bag.
6. When the task is complete, reseal the container and clean it with a wet wipe.
7. Do not remove the vacuum cleaner from its sealed container until you are in the work area and wearing appropriate PPE.
8. Do not reuse the essential filter element after removing from the appliance.
9. Dispose of all contaminated parts that cannot be cleaned.

DISPOSAL

Dispose of old vacuum cleaners and by-products e.g. filters, collection bags, vacuum tooling etc must be done in keeping with your national health and safety laws. We recommend as a minimum that items are placed in a sealed heavy duty, 200 µm (minimum thickness) polyethylene bag, labeled with an appropriate toxicity warning. These should then be taken to a facility that can lawfully accept hazardous waste of this type.

DO NOT clean the filter with compressed air. The absolute filter must be disposed of after use to maintain the integrity of the filter system and prevent unwanted hazardous dusts entering the environment.

WARNINGS:

- Kerrick does not have any clean room facilities and therefore cannot carry out service work and repairs on H Class vacuums (neither can any of our associated service agents) unless the vacuum cleaner can be certified as clean and safe to work on. If machines cannot be certified as clean by the contractor or another agent, we suggest contractors treat these vacuum cleaners as 'disposable' and price them into jobs from the outset.

MAINTENANCE

- For maintenance work suitable precautions must be taken in a cleaner room environment including decontamination before dismantling, a forced exhaust air ventilation system must be used in the room and staff must wear appropriate PPE.
- The user or a trained person must carry out a technical check at least once a year which consists of, for example, of checking filters, searching for damages to air-tightness of the device and the correct functioning of the control mechanism.
- The filtering efficiency of the device must be checked at least once a year.
- If the power cord is damaged, stop use and take it in to be repaired by the manufacturer or a qualified service agent.
- When maintenance or repair operations are carried out, all contaminated elements which cannot be cleaned well must be eliminated.
- The vacuum cleaner must be checked before every use for evidence of bumps, dents and damages that may reduce the effectiveness of the seal.

To order a replacement HEPA filter use the reference code:
REF.07768 – HEPA CARTRIDGE – Filter surface: 12000cm².

PERFORMANCE

PULSAR 515 H: 1200 W max – 22560 hPa – 200 m³/h

PULSAR 429 H: 2800 W max – 22560 hPa – 400 m³/h

Noise Level: Values are measured according to EN 60704 – 1 (1996) / EN 60704 – 2 – 1 (2000) rules. Measurement A for the sound pressure level of the machines is <81 dB(A).

Under unfavourable feed conditions, the appliance may cause temporary drops in voltage.

TROUBLE SHOOTING

Dry Vacuum Cleaners		
Trouble	Possible Cause	Remedy
Insufficient vacuum	Filter clogged and blocking airflow	Clean filter and empty tank.
	Faulty motor	Once certified as clean, return to Kerrick or Kerrick Service agent and have motor replaced.
	Hose or tooling are cracked and disrupting suction	Repair and replace as required
Vacuum overheats	Filter clogged and blocking airflow	Clean filter and empty tank.
	Faulty motor	Once certified as clean, return to Kerrick or Kerrick Service agent and have motor replaced.

SERVICING

Kerrick's workshop facilities are staffed by experienced technicians providing servicing, repair and manufacturing for a range of products including; vacuum cleaners, extractors, water blasters, pressure cleaners, pumps and more.

We work on everything from commercial and light industrial to large heavy duty equipment and offer customized design build services. We also warehouse and ship a comprehensive range of spare parts for your convenience.

WARNINGS:

- Kerrick does not have any clean room facilities and therefore cannot carry out service work and repairs on H Class vacuums (neither can any of our associated service agents) unless the vacuum cleaners can be certified as clean and safe to work on. If machines cannot be certified as clean by the contractor or another agent, we suggest contractors treat these vacuum cleaners as 'disposable' and price them into jobs from the outset.

For more information on your product or to order spare parts give Kerrick a call or send through and enquiry on our website. Contact details can be seen below:

KERRICK NEW ZEALAND

0800 2 KERRICK (0800 253 774)
SALES@KERRICK.CO.NZ
WWW.KERRICK.CO.NZ

KERRICK AUSTRALIA

1300 KERRICK (1300 537 742)
SALES@KERRICK.COM.AU
WWW.KERRICK.COM.AU

Relazione No. : **D9/8244E**

Data di emissione : 1 Ottobre 2009

Tipo di prove : **EMC** (prove per mercato australiano)

Eseguite presso : il laboratorio UL INTERNATIONAL ITALIA

Prove richieste da : **SOTECO S.p.A.**
Via Enrico Fermi, 2
26022 Castelverde (CR)
Italy

Norme applicate : AS/NZS CISPR 14.1 (2003)
AS/NZS 61000-3-2 (2007)
AS/NZS 61000-3-3 (2006)
AS/NZS CISPR 14.2 (2003)

Tipo di apparecchio : Aspirapolvere

Marca e Modello / Tipo : SOTECO – PULSAR 515A-H

Esito delle prove : **POSITIVO**

Provato da:



Francesco Casati
Laboratory Technician
UL International Italia S.r.l.
Tel. ++ 39 / 02 92 50 35 14
e-mail: Francesco.Casati@it.ul.com

Controllato da:



Ing. Dario Rivoltella
Laboratory Manager
UL International Italia S.r.l.
e-mail: Dario.Rivoltella@it.ul.com

Allegati: Test Report No. D9/8244E e Certificato UL EMC n° 09CA45887



Compliance Certificate

Company name and Location: SOTECO S.p.A. Via Enrico Fermi, 2 – 26022 Castelvetro (CR) – Italy
File Number: 09CA45887 **Date of Report:** October 1st, 2009

Product Description: VACUUM CLEANER

Investigated in accordance with: AS/NZS CISPR 14.1 (2003); AS/NZS CISPR 14.2 (2003);
AS/NZS 61000-3-2 (2007); AS/NZS 61000-3-3 (2006)

Model Designation: PULSAR 515A-H

Serial Number: ---

Job Number: D9/8244E

A sample of the product described above has been investigated by Underwriters Laboratories Inc. in accordance with the requirements indicated on this Certification and has been found in compliance with those requirements. It is the responsibility of the company shown above that the products it produces are in compliance with the applicable requirements.

The name of Underwriters Laboratories Inc. (UL), any abbreviation thereof, or any symbol shall not be used on or in connection with the product unless and until specifically authorized by UL.

Tested by:

Luigi Casati

(P.I. Francesco Casati)

Reviewed by:

Dario Rivoitella

(Eng. Dario Rivoitella)



Any information and documentation involving UL Mark services are provided on behalf of Underwriters Laboratories Inc. (UL) or any authorized licensee of UL.



Relazione No. : **D9/8247M**

Data di emissione : 1 Ottobre 2009

Tipo di prove : Campi Elettromagnetici

Eseguite presso : il laboratorio UL INTERNATIONAL ITALIA

Prove richieste da : **SOTECO S.p.A.**
Via Enrico Fermi, 2
26022 Castelveverde (CR)
Italy

Norme applicate : IEC 62233 (2005); EN 62233 (2008)

Tipo di apparecchio : Aspirapolvere

Marca e Modello / Tipo : SOTECO – PULSAR 515A-H

Esito delle prove : **POSITIVO**

Provato da:

Francesco Casati
Laboratory Technician
UL International Italia S.r.l.
Tel. ++ 39 / 02 92 50 35 14
e-mail: Francesco.Casati@it.ul.com

Controllato da:

Ing. Dario Rivoltella
Laboratory Manager
UL International Italia S.r.l.
e-mail: Dario.Rivoltella@it.ul.com

Allegati: Test Report No. D9/8247M e Attestato di conformità



Statement of Conformity

Company Name and Location: SOTECO S.p.A.

Via Enrico Fermi, 2 – 26022 Castelverde (CR) – Italy

File Number: 09CA45887

Date of Report: October 1st, 2009

Product Description: VACUUM CLEANER

Investigated in accordance with IEC 62233 (2005); EN 62233 (2008)

Models Designation: PULSAR 515A-H

Job Number: D9/8247M

A sample of the product described above has been investigated by Underwriters Laboratories Inc. in accordance with the requirements indicated on this Certification and has been found in compliance with those requirements. It is the responsibility of the company shown above that the products it produces are in compliance with the applicable requirements.

The name of Underwriters Laboratories Inc. (UL), any abbreviation thereof, or any symbol shall not be used on or in connection with the product unless and until specifically authorized by UL.

Tested by:

A handwritten signature in blue ink, appearing to read 'Casati F.' followed by a stylized flourish.

P.I. Francesco Casati

Reviewed by:

A handwritten signature in blue ink, appearing to read 'Rivestume Deni'.

P.I. Francesco Casati

Any information and documentation involving UL Mark services are provided on behalf of Underwriters Laboratories Inc. (UL) or any authorized licensee of UL.



Ref. Certif. No.

DK-17135

IEC SYSTEM FOR MUTUAL RECOGNITION OF TEST
CERTIFICATES FOR ELECTRICAL EQUIPMENT (IECEE)
CB SCHEMESYSTEME CEI D'ACCEPTATION MUTUELLE DE CERTIFICATS
D'ESSAIS DES EQUIPEMENTS ELECTRIQUES (IECEE)
METHODE OCCB TEST CERTIFICATE
CERTIFICAT D'ESSAI OCProduct
Produit**Dry vacuum cleaner for industrial and commercial use
(including dust protection Annex AA of IEC 60335-2-69)**Name and address of the applicant
Nom et adresse du demandeur**SOTECO S.P.A
Via E. Fermi, 2 26022 CASTELVERDE (CR) – Italy**Name and address of the manufacturer
Nom et adresse du fabricant**SOTECO S.P.A
Via E. Fermi, 2 26022 CASTELVERDE (CR) – Italy**Name and address of the factory
Nom et adresse de l'usine**SOTECO S.P.A
Via E. Fermi, 2 26022 CASTELVERDE (CR) – Italy**

Note: When more than one factory, please report on page 2
Note: Lorsque il y plus d'une usine, veuillez utiliser la 2^{me} page

Ratings and principal characteristics
Valeurs nominales et caractéristiques principales**240V~ 50-60Hz, 1000W 1200W max, IPX4, Class II**Trademark (if any)
Marque de fabrique (si elle existe)**KERRICK**Model / Type Ref.
Ref. De type**PULSAR 515A-H**

Additional information (if necessary may also be reported
on page 2)
Les informations complémentaires (si nécessaire, peuvent
être indiqués sur la 2^{ème} page)

inclusive Australia deviation

A sample of the product was tested and found
to be in conformity with
Un échantillon de ce produit a été essayé et a été
considéré conforme à la

PUBLICATION	EDITION
IEC 60335-1:2001 +A1:2004 +A2:2006,	4th
IEC 60335-2-69:2002 + A1:2004 + A2:2007	3rd

As shown in the Test Report Ref. No. which forms part of
this Certificate
Comme indiqué dans le Rapport d'essais numéro de
référence qui constitue partie de ce Certificat

D9/8315 issue date 2009-10-26

This CB Test Certificate is issued by the National Certification Body
Ce Certificat d'essai OC est établi par l'Organisme **National de Certification**



UL International Demko A/S
Lyskaer 8, P.O. Box 514, DK-2730 Herlev, Denmark
Tel: +45 44856565, Fax: +45 44856500

Date:
2009-10-30

Signature:

Jan-Erik Storgaard
Certification manager