

# PROFESSIONAL PROF. SUPER

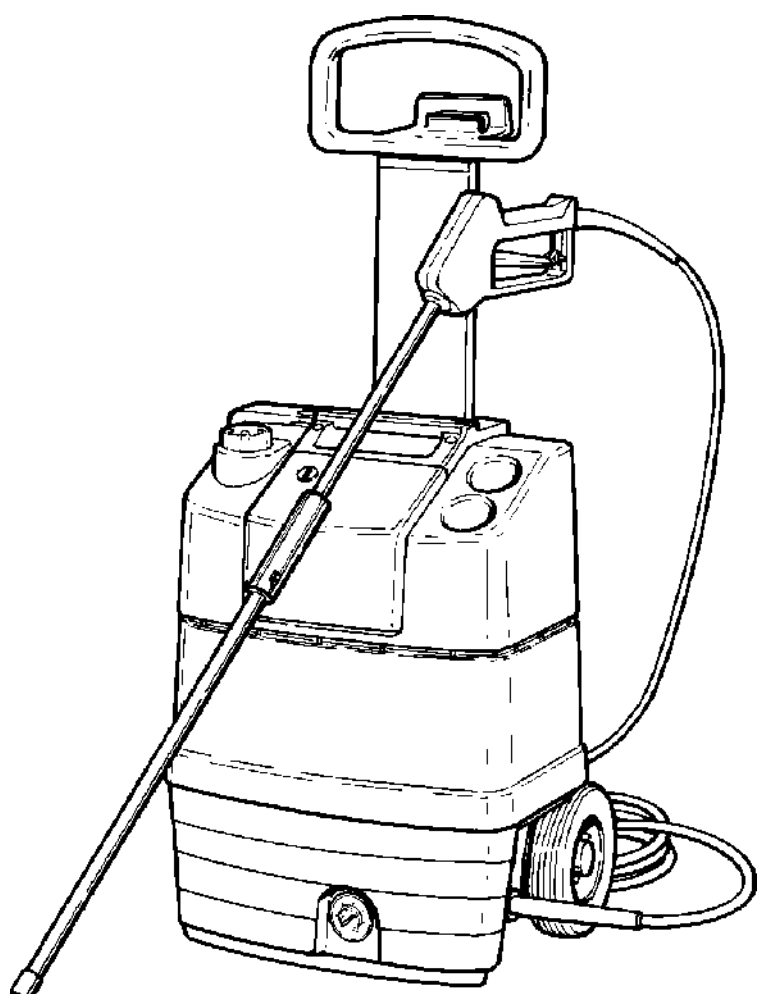

ALTO®

Total Cleaning  
Confidence™

Reserve de le  
Spare parts  
Ersatzteile  
Pièces détachées

598 51 12 - Sep. 01

**1** INDEX  
**3**

KEW  
TECHNOLOGY

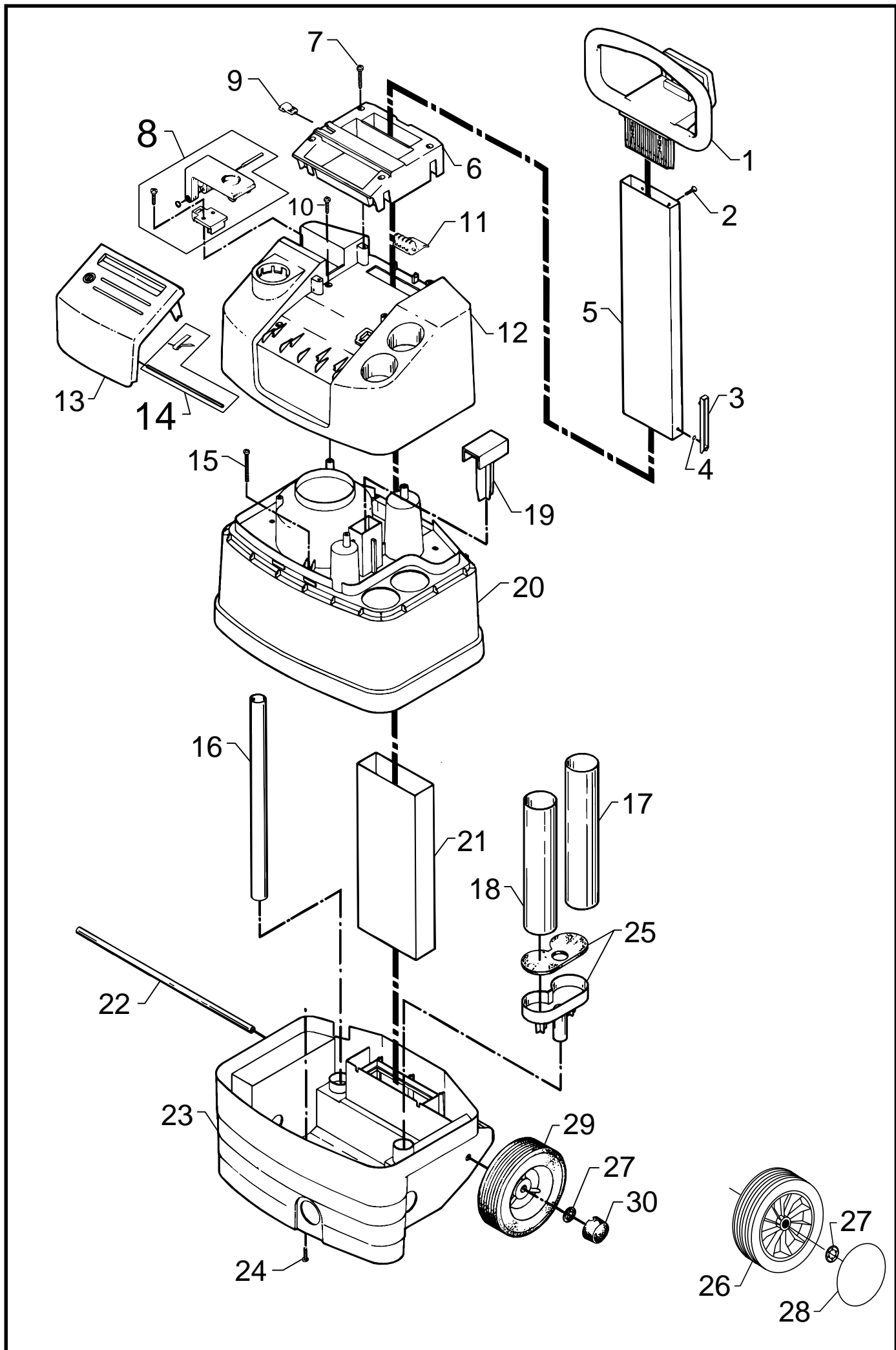

5985112 - Sep. 01



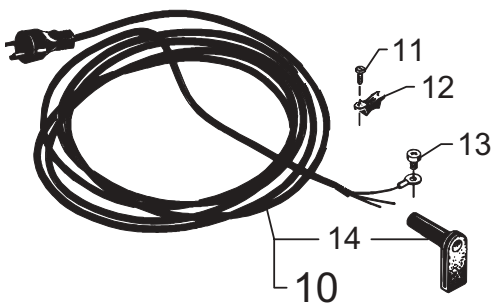
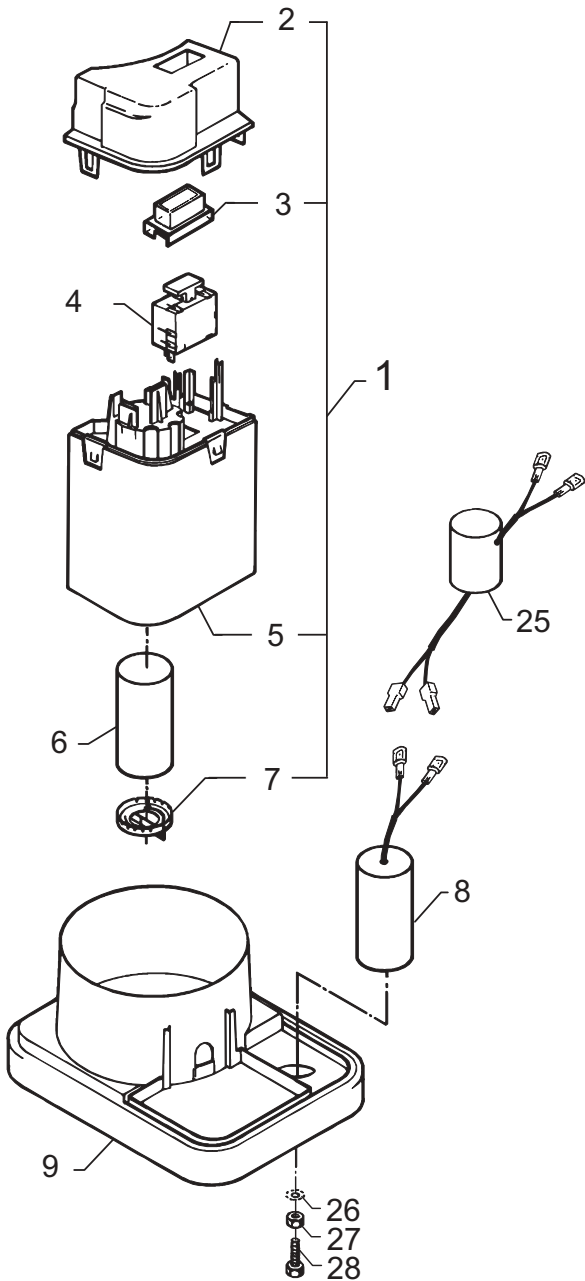
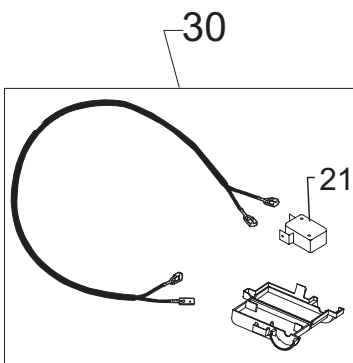
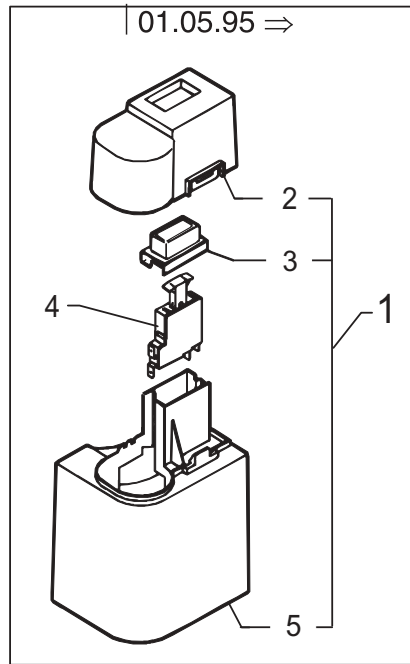
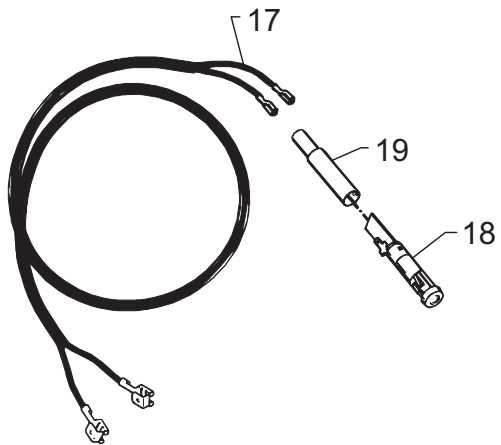

Pos. Ref.	Nr. No.	Betegnelse Bezeichnung	Designation Désignation	5100/9000	5500 SUPER	6100/9100	6500 SUPER
30	-	El-enhed, komplet El. unit, compl. El. Einheit, komplett Unité électrique		x	x	x	x
1	6125548	El-enhed El. unit El. Einheit Unité électrique	01.05.95 ⇒	x	x	x	x
1	6122650	El-enhed El. unit El. Einheit Unité électrique	⇒01.05.95   USA, CDN	x	x	x	x
2	6122153	Top for el-enhed Top for el. unit Oberteil der el. Einheit Dessus de l'unité électrique	01.05.95 ⇒	1	1	1	1
2	6122108	Top for el-enhed Top for el. unit Oberteil der el. Einheit Dessus de l'unité électrique	⇒01.05.95   USA, CDN	1	1	1	1
3	6122105	Gummihætte Rubber cap Gummikappe Manteau caoutchouc		1	1	1	1
4	3821341	Trykkontakt, 50 Hz-12 A Pushbutton switch Druckschalter Interrupteur-poussoir	01.05.95 ⇒				
4	6124300	Trykkontakt, 50 Hz-9,5 A Pushbutton switch Druckschalter Interrupteur-poussoir	⇒01.05.95				
-	6124301	Trykkontakt m. adapter, 50 Hz-12 A Button switch w. adaptor Druckschalter m. Adapter Interrupteur-poussoir a. adapteur	⇒01.05.95				
-	3817012	Trykkontakt Pushbutton switch Druckschalter Interrupteur-poussoir	15 A USA, CDN	1	1		
5	6122150	Sokkel for el. enhed Socket for el. unit Gestell für el. Einheit Base p. unité électrique	01.05.95 ⇒	1	1	1	1
5	6122106	Sokkel for el. enhed Socket for el. unit Gestell für el. Einheit Base p. unité électrique	⇒01.05.95   USA, CDN	1	1	1	1
6	3821343	Kondensator (drift) Capacitor (operation) Kondensator (Betrieb) Condensateur (fonction.)	50 µF	1	1	1	1
-	3821063	Kondensator (start) Capacitor (start-up) Kondensator (Start) Condensateur (marche)	USA, CDN 160 µF	1	1		
7	6122107	Låseskive Lock washer Federtellerscheibe Circlip	⇒01.05.95   USA, CDN	1	1	1	1
8	3821342	Kondensator (start) Capacitor (start-up) Kondensator (Start) Condensateur (marche)		1	1	1	1
-	3821410	Kondensator (drift) Capacitor (operation) Kondensator (Betrieb) Condensateur (fonction.)	USA, CDN 100 µF	1	1		
9	6127585	Kabinettfender Cabinetfender Gehäusefender Amortisseur capot		1	1	1	1
-	6124394	Kabinettfender Cabinetfender Gehäusefender Amortisseur capot	USA, CDN	1	1		

Pos. Ref.	Nr. No.	Betegnelse Bezeichnung	Designation Désignation	5100/9000	5500 SUPER	6100/9100	6500 SUPER
10	-	El-kabel med stik El. cable with plug Anschlusskabel mit Stecker Câble électrique + prise		x	x	x	x
-	-	GB, SGP A, D, F DK NZ, Aus	10/12 A 10/12 A 10 A 12 A				
-	6124327						
-	6124328						
-	6126931						
-	6124329	CH HK, ZA USA CDN	10/12 A 10/12 A 15 A 15 A				
-	6124330						
-	6122205						
-	6122206						
11	6122531	Skrue Screw Schraube Vis		2	2	2	2
12	3806262	Trækafastning Cable lead-in Zugentlastung Dispositif d'attaque auxil.		1	1	1	1
13	1809847	Jordskrue Earth screw Erdschraube Vis de terre		1	1	1	1
14	6122125	Gummitulle Rubber bush Gummitülle Douille p. câble, caoutchouc		1	1	1	1
17	3821393	Lampeledning, s/s Cable f. light indicator, s/s Lampenkabel, S/S Câble p. lampe, m/a		1	1	1	1
18	3821432	Lampe, s/s Light indicator, s/s Lampe, S/S Lampe, m/a		1	1	1	1
19	6522791	Lampetætning Sealing f. light indicator Lampendichtung Joint p. lampe		1	1	1	1
21	3821711	Kontakt, s/s Micro switch, s/s Schalter, S/S Contacteur, m/a		1	1	1	1
25	6124081	Ledning f. kond. (drift) Cable f. capacitor (operation) Kabel f. Kondensator (Betrieb) Câble p. condensateur (fonction.)	USA, CDN	1	1		
26	1807445	Skive Washer Scheibe Rondelle		1	1	1	1
27	1803725	Møtrik Nut Mutter Ecrou		1	1	1	1
28	6124235	Bolt Stud Bolzen Boulon	USA, CDN	1	1	1	1
30	6126973	Box m. kontakt + ledning Box w. switch + cable Gehäuse m. Schalter + Kabel Boîte a. micro-switch + câble		1	1	1	1

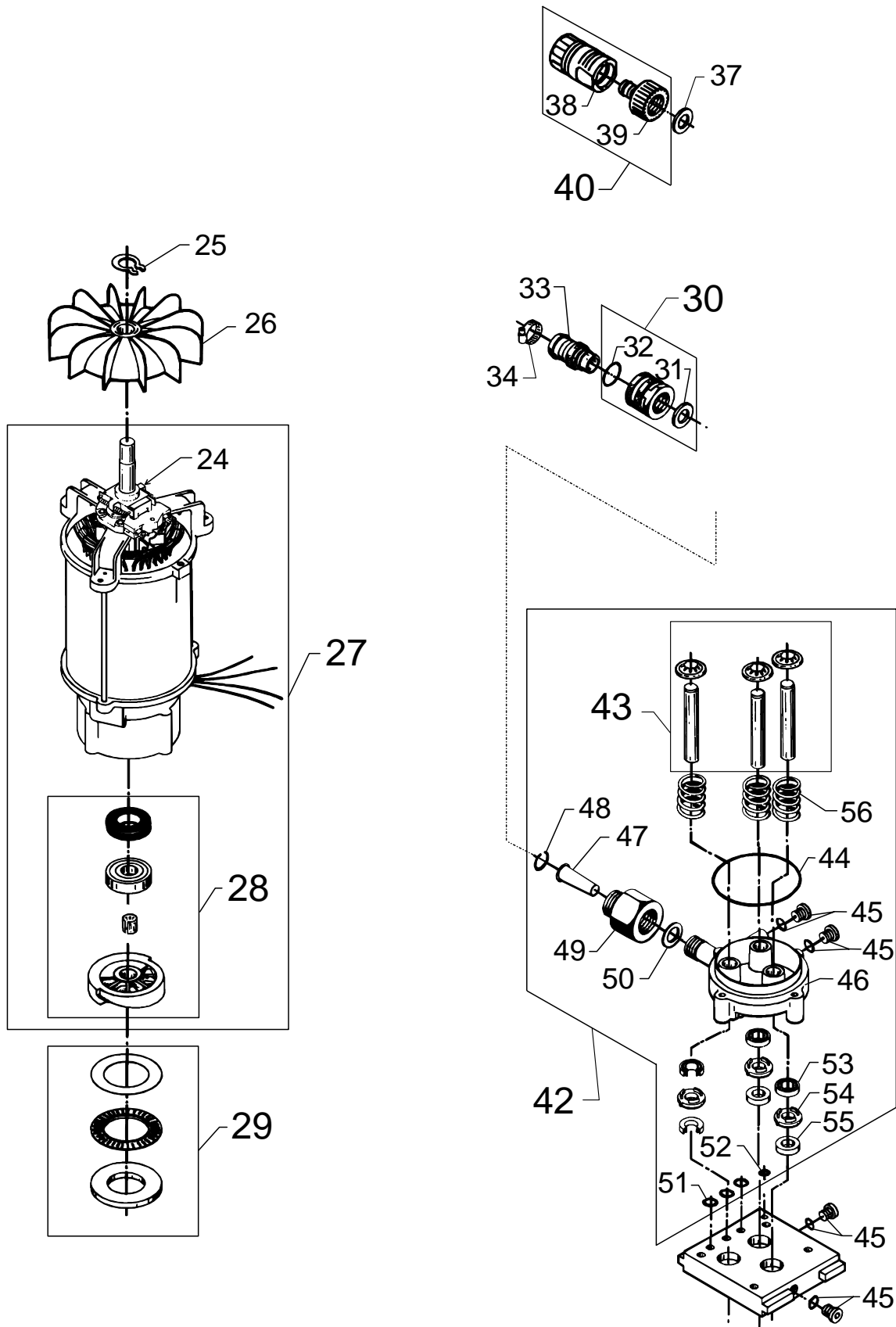



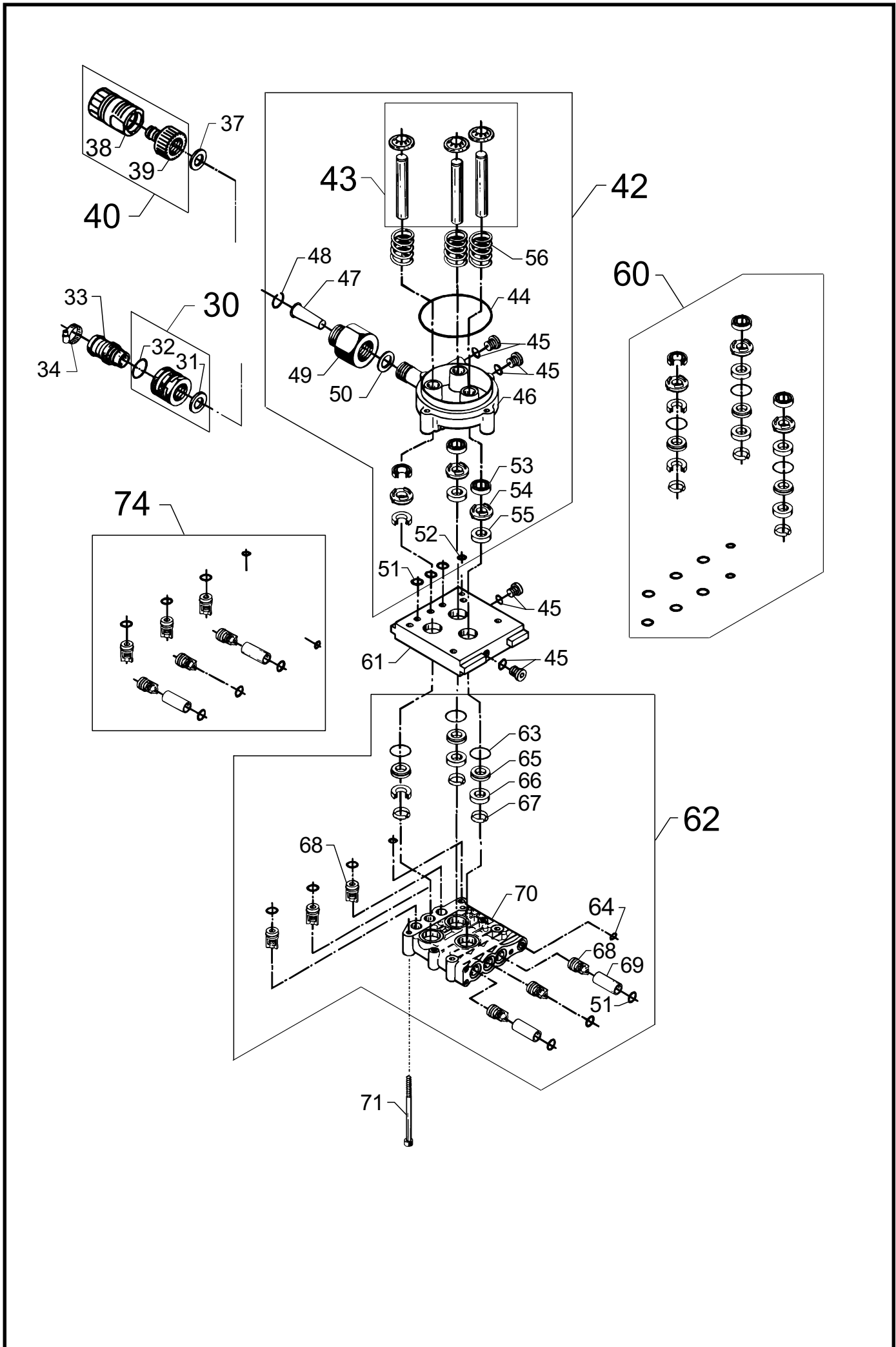





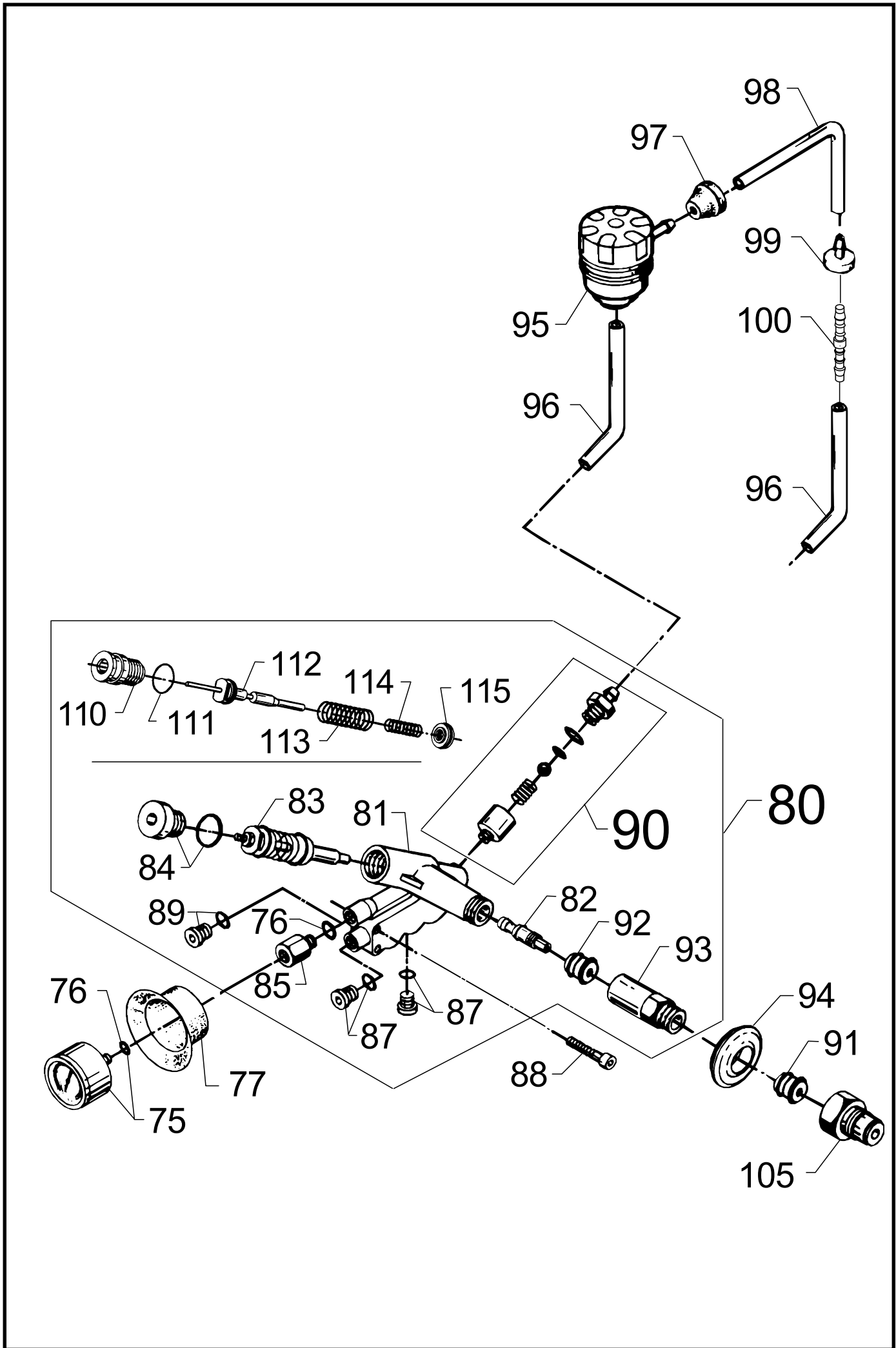

Pos. Ref.	Nr. No.	Betegnelse Bezeichnung	Designation Désignation	SUPER			
				5100 / 9000	5500	6100 / 9100	6500
75	6122315	Manometer med O-ring Pressure gauge with O-ring Manometer mit O-Ring Manomètre avec joint torique		1	1	1	1
76	3003662	O-ring O-ring O-Ring Joint torique		2	1	2	1
77	6124163	Gummi manchete Rubber seal Gummimanschette Joint à lévre, caoutch.		1	1	1	1
<b>80</b>	-	<b>Omløbsventil, komplet</b> <b>By-pass valve, complete</b> <b>Umlaufventil, komplett</b> <b>Soupape by-pass, compl.</b>					
-	6124308	12A		x		x	
-	6124340	12A			x		
-	6124339	10A		x		x	
-	6124309	10A			x		
-	6126932	Spec. USA		x			
-	6126933	Spec. USA			x		
-	6124341	Spec. D		x	x		
<b>80</b>	-	<b>Omløbsventil f. s/s, komplet</b> <b>By-pass valve f. s/s, complete</b> <b>Umlaufventil f. S/S, komplett</b> <b>Soupape by-pass p. m/a, compl.</b>					
-	6523004	12A				x	
-	6523006	12A					x
-	6523005	10A		x	x	x	x
-	6523007	Spec. D für S/S		x	x	x	x
81	-	Ventilhus Valve housing Ventilgehäuse Boîte de soupape					
-	6122602			1		1	
-	107180690	Messing / brass / Messing / laiton			1		1
-	6124238	Spec. D		1	1	1	1
<b>82</b>	-	<b>Styredyse, komplet</b> <b>Steering nozzle, compl.</b> <b>Steuerdüse, kompl.</b> <b>Buse de guidage, compl.</b>					
-	6122365	grøn, green, grün, vert		1	1	1	1
-	6124311	blå, blue, blau, bleu		1	1	1	1
-	6124312	Spec. D		1	1	1	1
-	6122365	Spec. USA, CDN		1	1		
83	6124313	Ventilkegle, komplet Valve cone, complete Ventilkegel, komplett Cône p. clapet, compl.		1	1	1	1
84	6123654	Prop med O-ring Plug with O-ring Pfropfen mit O-Ring Manchon avec joint torique		1		1	
-	6124334	Prop med O-ring, messing Plug with O-ring, brass Pfropfen mit O-Ring, Messing Manchon avec joint torique, laiton			1		1
85	6124127	Afstandsstykke Spacer for pressure gauge Ansatzstück für Manometer Rallonge p. Manomètre		1		1	
87	6123655	Prop med O-ring Plug with O-ring Pfropfen mit O-Ring Manchon avec joint torique		2		2	
-	6180913	Prop med O-ring, messing Plug with O-ring, brass Pfropfen mit O-Ring, Messing Manchon avec joint torique, laiton			2		2
88	1814573	Skrue Schraube Vis		3	3	3	3
89	6180913	Prop med O-ring Plug with O-ring Pfropfen mit O-Ring Manchon avec joint torique		1		1	

Pos. Ref.	Nr. No.	Betegnelse Bezeichnung	Designation Désignation	SUPER			
				5100 / 9000	5500	6100 / 9100	6500
<b>90</b>	6124314	<b>Slangestuds, kompl.</b> <b>Hose tail, compl.</b> <b>Schlauchstutzen, kompl.</b> <b>Raccord de tuyau, compl.</b>		1	1	1	1
91	6124346	Nippel m. O-ring, messing Nipple w. O-ring, brass Nippel m. O-Ring, Messing Adaptateur a. joint torique, laiton			1		1
92	6124316	Nippel m. O-ring Nipple w. O-ring Nippel m. O-Ring Adaptateur a. joint torique		1	1	1	1
93	6124126	Gevindestykke Threaded piece Gewindestück Pièce avec filetage		1		1	
-	6124169	Gevindestykke, messing Threaded piece, brass Gewindestück, Messing Pièce avec filetage, laiton			1		1
94	6124164	Gummi manchete Rubber seal Gummimanschette Joint à lévre, caoutch.		1	1	1	1
95	6124317	Doserventil Dosing valve Dosierungsventil Soupape de dosage		1	1	1	1
96	6124318	Slange Hose Schlauch Flexible		1	2	1	2
97	3803780	Pakdåse Cable grommet Stopfbuchse Presse-étoupe	TET 10-14C	1	1	1	1
98	6124319	Slange Hose Schlauch Flexible		1	1	1	1
99	6400240	Filter Filter Filter Filtre		1	1	1	1
100	1609114	Slangestuds Hose tail Schlauchstutzen Raccord de flexible			1		1
105	1402569	Lynkoblingsnippel (højtryk) Nipple f. quick coupling (H.p.) Nippel f. Schnellkupplung (H.d.) Entrée du coupleur rapide (h. pr.)			1		1
<b>110</b>	<b>6523000</b>	<b>Pakdåse, kompl.</b> <b>Stuffing box, compl.</b> <b>Stopfbuchse, kompl.</b> <b>Presse-étoupe, compl.</b>		1	1	1	1
111	3004245	O-ring O-ring O-Ring Joint torique		1	1	1	1
<b>112</b>	<b>6523001</b>	<b>Stempel f. s/s, kompl.</b> <b>Piston f. s/s, compl.</b> <b>Kolben f. S/S, kompl.</b> <b>Piston p. m/a, compl.</b>		1	1	1	1
113	2602431	Fjeder, stor Spring, big Feder, gros Ressort, gros		1	1	1	1
114	2602449	Fjeder, lille Spring, small Feder, klein Ressort, petit		1	1	1	1
<b>115</b>	<b>6523002</b>	<b>Sæde f. s/s, kompl.</b> <b>Seat f. s/s, compl.</b> <b>Sitz f. s/s, kompl.</b> <b>Siège p. m/a, compl.</b>		1	1	1	1
-	5301425	Pump Oil 46, 1x1 l		x	x	x	x