

03KB C3KB

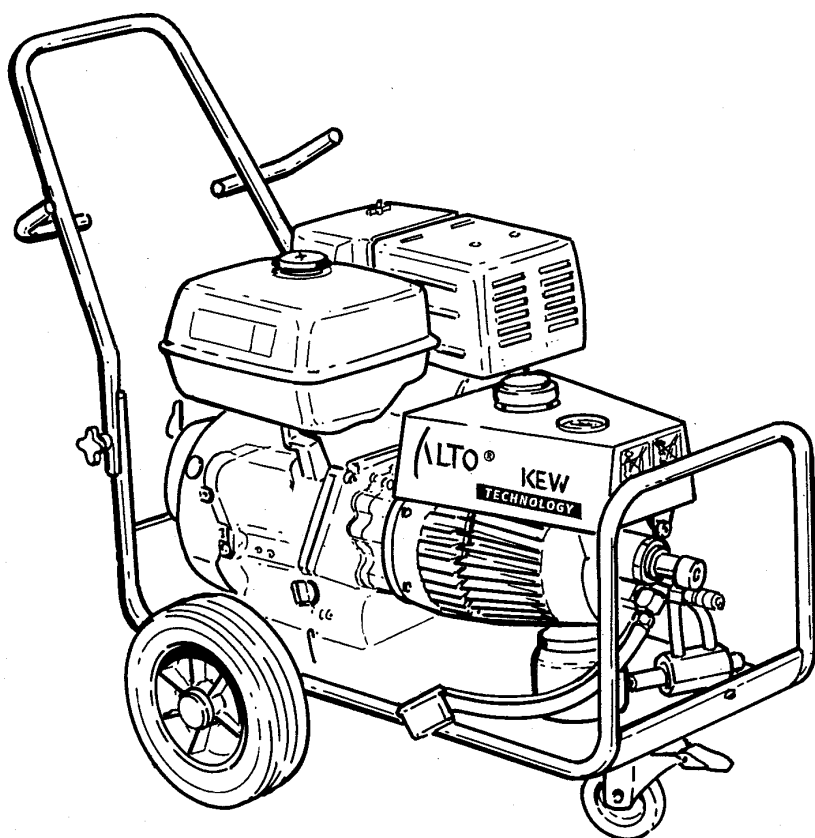

ALTO®

Total Cleaning
Confidence™

Reserve de le
Spare parts
Ersatzteile
Pièces détachées

Kabinet / Cabinet / Gehäuse / Capot

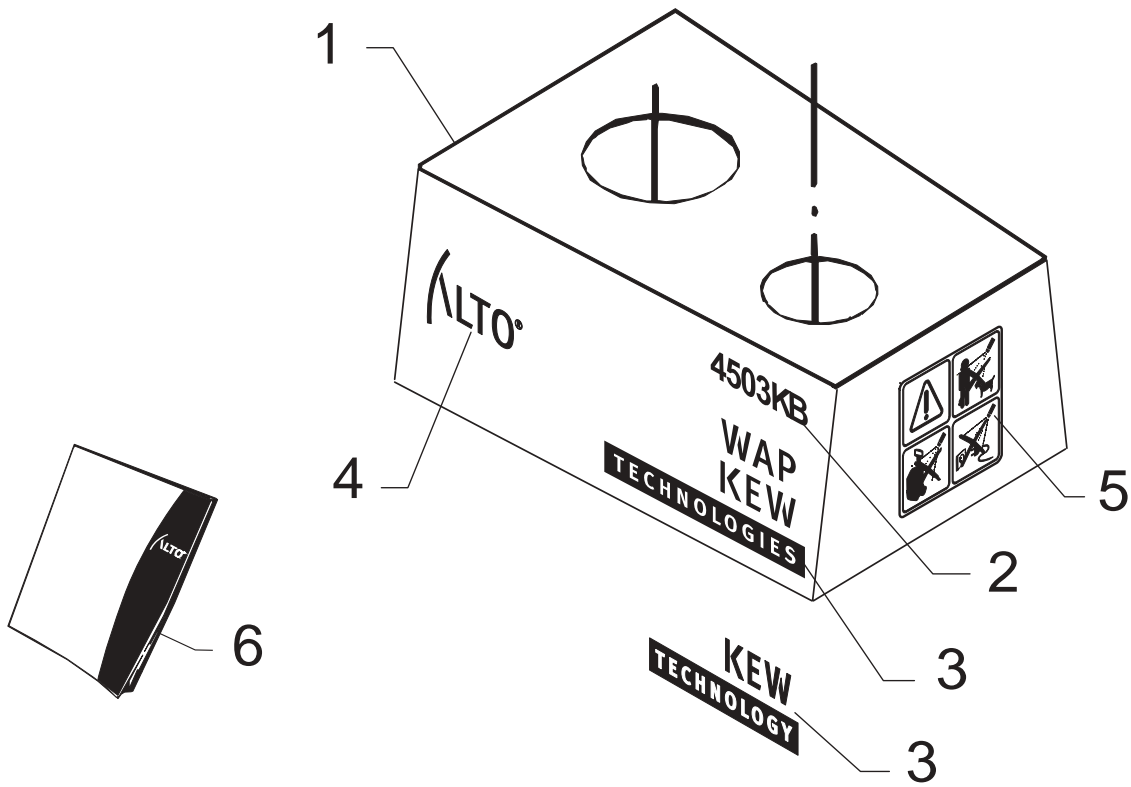

Motorpumpeenhed, mont. i stel / Motor pump unit, m. in chassis /
Motorpumpenkörper, im Rahmen / Corps de moteur m. p. châssis

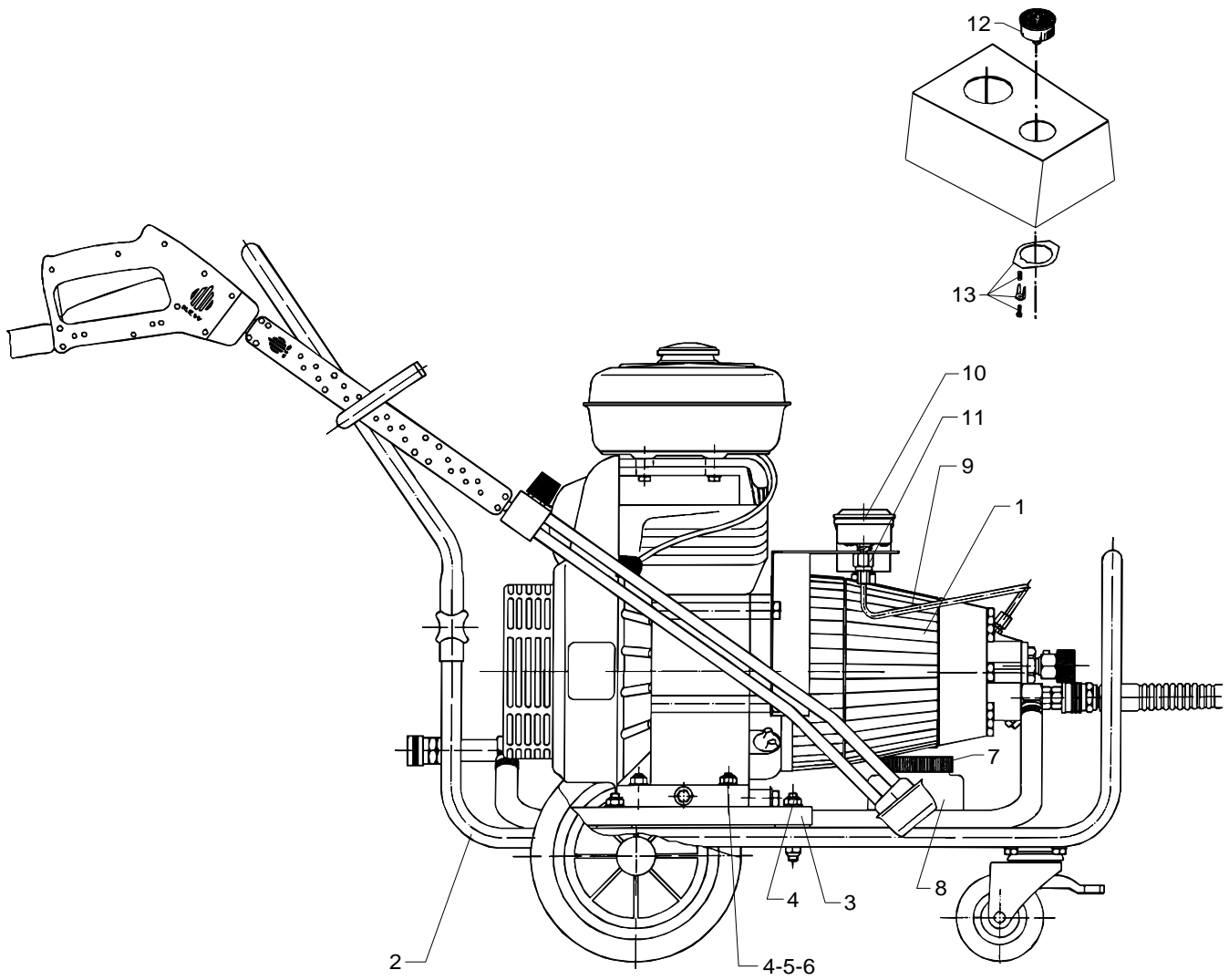

Pos. Ref.	Nr. No.	Betegnelse Bezeichnung	Designation Désignation	4203KB	45C3-03
-	-	Motorpumpeenhed, mont. i stel Motor pump unit, m. in chassis Motorpumpenkörper, im Rahmen Corps de moteur m. p. châssis		x	x
1	-	Motorpumpeenhed Motor/pump unit Motorpumpenkörper Corps de moteur/pompe	Se side See page Siehe Seite Voir page	10 10 10 10	
2	-	Stel, kompl. Chassis, compl. Rahmen, kompl. Châssis, compl.	Se side See page Siehe Seite Voir page	8 8 8 8	
3	6162909	Motorplade Motor plate Motorplatte Plaque moteur		1	1
4	1801257	Låsemøtrik Lock nut Gegenmutter Ecrou de blocage		9	9
5	1800317	Skive Washer Scheibe Rondelle		9	9
6	1803964	Skrue Screw Schraube Vis		4	4
7	6101625	Slamglaslæg Cover f. sludge container Deckel f. Schlammglas Couvercle, resv. d'huile usée		1	1
8	2200467	Slamglas Sludge container Schlammglas Reservoir d'huile usée		1	1
9	6162914	Manometerrør Pressure gauge tube Manometerrohr Tube p. manomètre		1	
-	6162402	Manometerrør Pressure gauge tube Manometerrohr Tube p. manomètre			1
10	3601262	Manometer Pressure gauge Manometer Manomètre		1	
11	1600535	Manometerforskrning Threaded connection f. pressure gauge Manometerverschraubung Raccord fileté de manomètre		1	
12	3600996	Manometer Pressure gauge Manometer Manomètre			1
13	3601036	Beslag f. manometer Fitting f. pressure gauge Spannstück f. Manometer Pièce de serrage p. manomètre		1	

Pos. Ref.	Nr. No.	Betegnelse Bezeichnung	Designation Désignation	4203KB	45C3-03

Stel / Chassis / Rahmen / Châssis

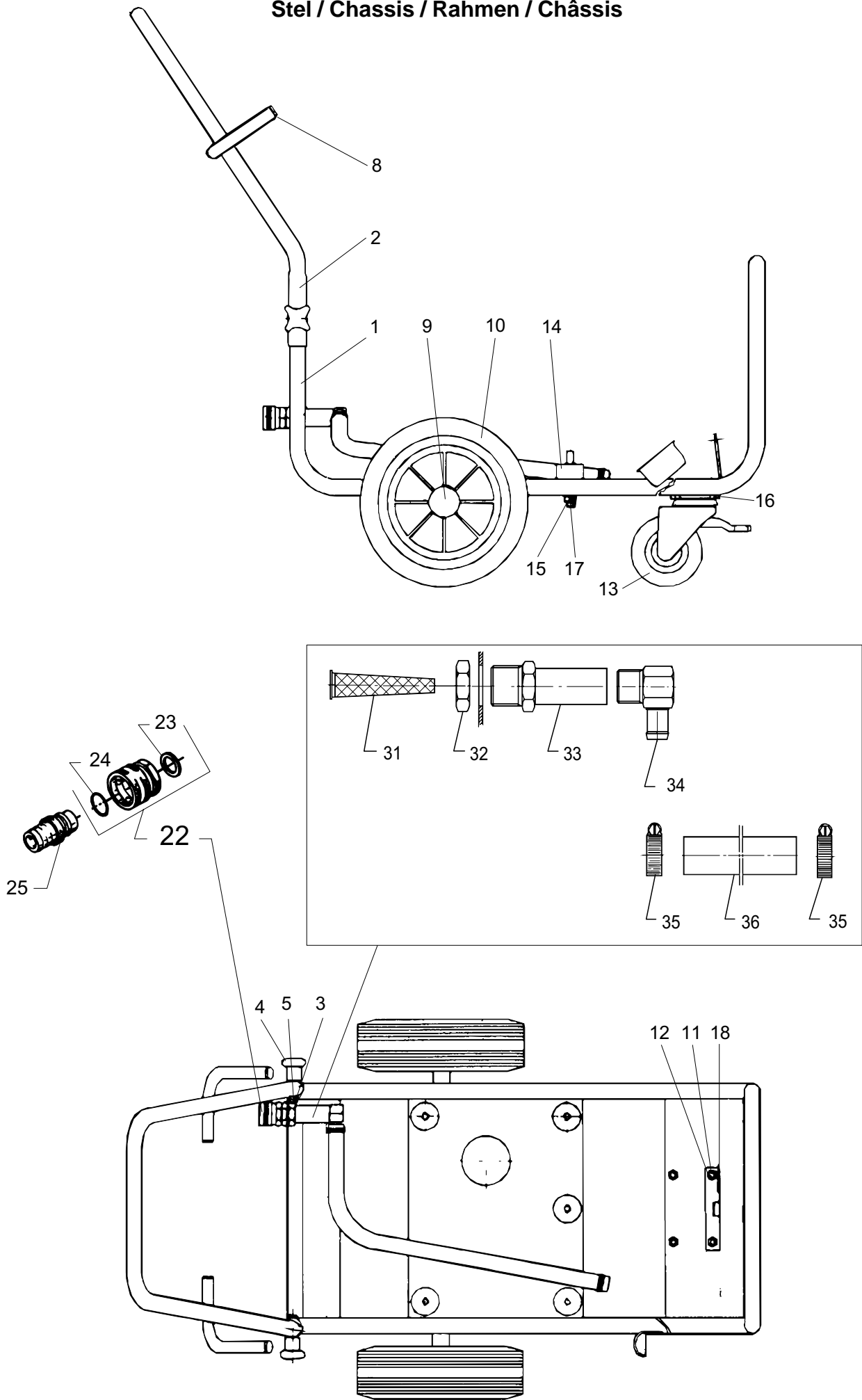

Pos. Ref.	Nr. No.	Betegnelse Bezeichnung	Designation Désignation	4203KB	45C3-03
-	-	Stel, kompl. Chassis, compl. Rahmen, kompl. Châssis, compl.		x	x
1	6162938	Stel Chassis Rahmen Chassis		1	1
2	6160937	Bagbøjle Clamp rear Bügel, hinten Collier, arrière		1	1
3	6100123	Skrue Screw Schraube Vis		2	2
4	4000279	Stjernegreb Star handle Sterngriff Bouton		2	2
5	4600559	Dupsko Ferrule Zwinge Fer		2	2
8	4600664	Dupsko Ferrule Zwinge Fer		4	4
9	102004266	Navkapsel, kompl. Hub cap, compl. Nabenkappe, kompl. Enjoliveur, compl.	01.03.02 =>	2	2
9	2004265	Navkapsel Hub cap Nabenkappe Enjoliveur	=> 28.02.02	2	2
10	301000041	Hjul Wheel Rad Roue	01.03.02 =>	2	2
10	-	Hjul Wheel Rad Roue	=> 28.02.02	2	2
11	1801398	Stjerneskrue Washer Scheibe Rondelle		4	4
12	1803725	Møtrik Nut Mutter Écrou		4	4
13	2012144	Drejehjul Steerable wheel Lenkrolle Roue pivotante		1	1
14	1801240	Gummiophæng Rubber suspension Gummiabhängung Suspension en caoutchouc		5	5
15	1801257	Låsemøtrik Lock nut Gegenmutter Écrou de blocage		5	5
16	1801174	Sætskrue Set screw Gewindestift Vis de blocage		4	4

Pos. Ref.	Nr. No.	Betegnelse Bezeichnung	Designation Désignation	4203KB	45C3-03
17	1800317	Skive Washer Scheibe Rondelle		5	5
18	6160951	Beslag Fitting Halter Support	=> 20.08.91	1	1
22	1602945	Lynkobling, kompl. Quick coupling, compl. Schnellkupplung, Kompl. Coupleur rapide, compl.		x	x
23	3001237	Pakning Gasket Dichtung Joint		1	1
24	3000320	O-ring O-ring O-Ring Joint torique		1	1
-	1600659	Lynkoblingsnippel, 3/4" Quick coupling nipple, 13/4" Schnellkupplungs-nippel, 3/4" Coupleur rapide mâle, 3/4"		1	1
-	1605955	Lynkoblingsnippel Quick coupl. nipple Schnellkupplungs-nippel Coupleur rapide mâle	USA		1
-	-	Vandtilgang, kompl. Water, inlet, compl. Wassereinlaß, Kompl. Tube d'admission, compl.		x	x
31	6100941	Filter Filter Filter Filtre		1	1
32	1800341	Kontramøtrik Lock nut Gegenmutter Contre écrou		1	1
33	6300255	Filterhus Housing f. filter Filtergehäuse Gaine de filtre d'eau		1	1
34	6101752	Slangestuds Hose socket Schlauchstutzen Raccord à tuyau		1	1
35	1802107	Spændebånd Hose clip Schlauchschelle Collier de serrage		2	2
36	5206230	Slange Hose Schlauch Tuyau	(L=700)	1	1

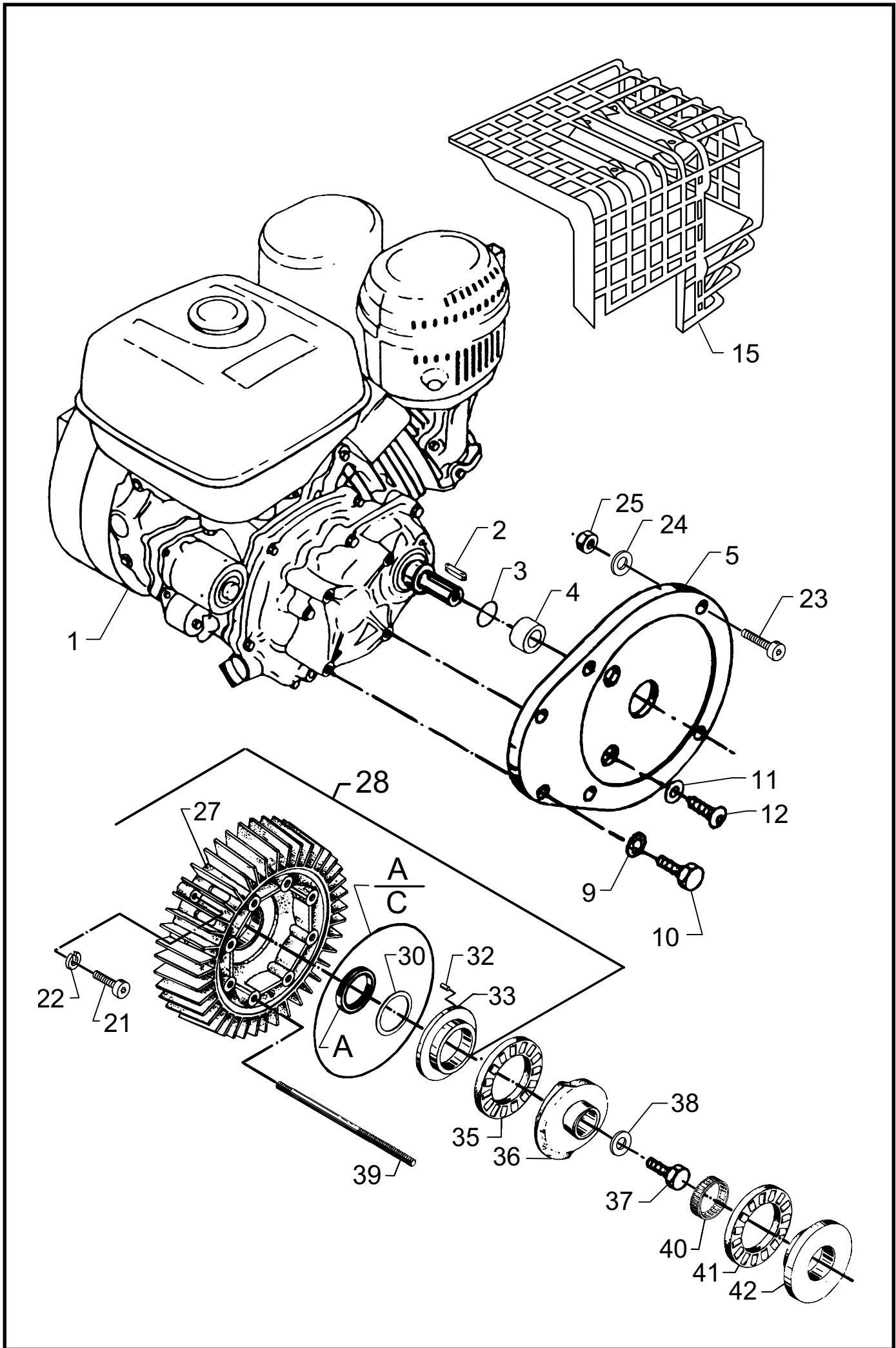

Pos. Ref.	Nr. No.	Betegnelse Bezeichnung	Designation Désignation	4203KB	45C3-03
-	-	Motorpumpeenhed, komp. Motor/pump unit, compl. Motorpumpenkörper, Corps de moteur/pompe		x	x
1	101119409	Motor Motor Motor Moteur	Honda GX 340K1 LX	1	1
2	6160608	Feder Key Federkeil Clavette		1	1
3	3001559	O-ring O-ring O-Ring Joint torique		1	1
4	6160607	Tætningsring Sealing ring Dichtungsring Rondelle d'étanchéité		1	1
5	6162601	Befæstigelsesplade Attachment plate Befestigungsblock Bloc de fixation		1	1
9	1801182	Fjederskive Spring washer Federscheibe Rondelle ressort		2	2
10	1800150	Sætskrue Set screw Gewindestift Vis de bloquage	M8x30	2	2
11	1801398	Skive Washer Scheibe Rondelle		2	2
12	1803949	Skrue Screw Schraube Vis	M8x20	2	2
15	6160613	Motorskjold Motor shield Motorschild Capotage		1	1
21	1803337	Skrue Screw Schraube Vis	M8x25	2	2
22	1801182	Fjederskive Spring washer Federscheibe Rondelle ressort		4	4
23	1813864	Skrue Screw Schraube Vis	M8x35	2	2
24	1800796	Skive Washer Scheibe Rondelle		2	2
25	1800515	Låsemøtrik Lock nut Gegenmutter Écrou de blocage	M8	1	1
27	6162606	D-lejedæksel Front bearing cover D-Lagerdeckel AV-flasque de carter		1	1
28	6162400	D-lejedæksel, komplet Front bearing cover, compl. D-Lagerdeckel, komplett AV-flasque de carter, compl.		x	x
30	6100995	Skive Washer Scheibe Rondelle		1	1
32	6100996	Styrestift Guide pin Kegelstift Goupille		1	1

Pos. Ref.	Nr. No.	Betegnelse Bezeichnung	Designation Désignation	4203KB	45C3-03
33	107120703	Lejeskive, tynd Bearing track, thin Lagerscheibe, dünn Rondelle de palier, mince		1	1
35	3200615	Rulleleje Roller bearing Rollenlager Roulement		1	1
36	107120717	Skråskive Wobble disc 13 Taumelscheibe Disque oblique		1	1
37	1800739	Sætskrue Set screw Gewindestift Vis de bloquage		1	1
38	6162603	Skive Washer Scheibe Rondelle		1	1
39	6100710	Stagbolt Stud Stehbolzen Entretoise		8	8
39	6301368	Stagbolt Stud Stehbolzen Entretois		C3	8
40	3200664	Nåleleje Needle bearing Nadellager Roulement à aiguille		1	1
41	3200615	Aksialrulleleje Axial roller bearing Axialrollenlager Roulement		1	1
42	107120704	Lejeskive Bearing track Lagerscheibe Plaque de palier		1	1

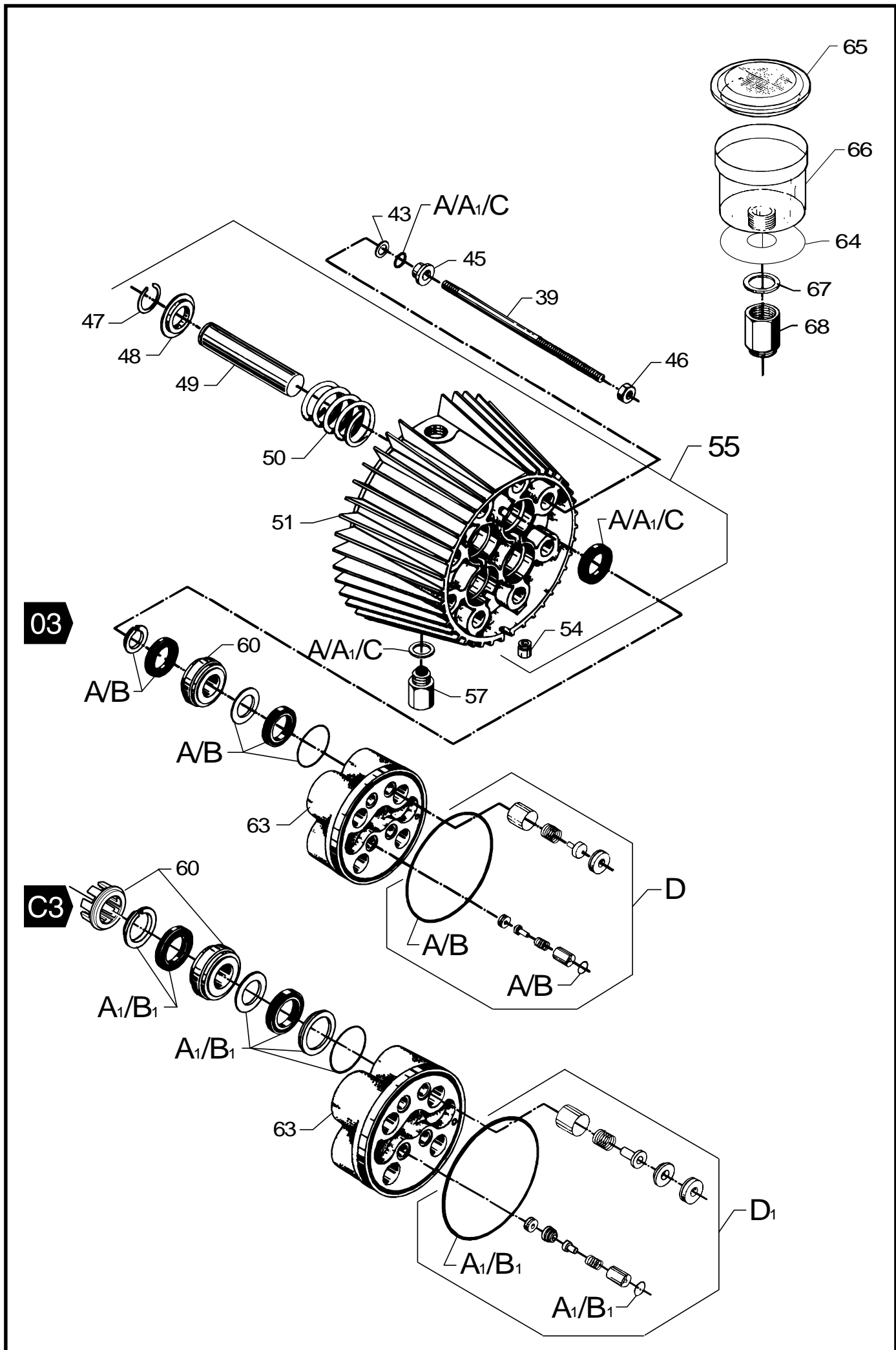

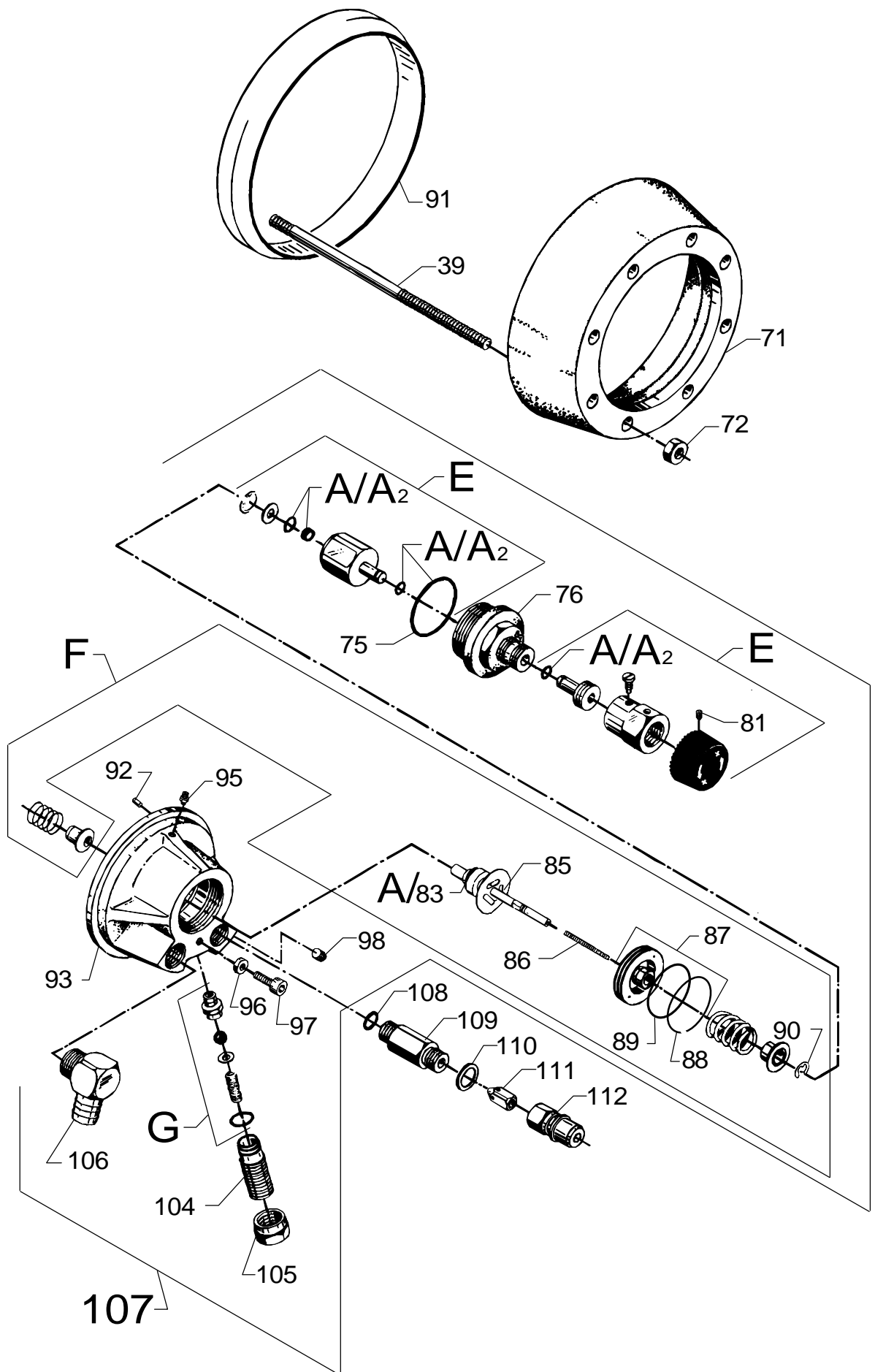

Pos. Ref.	Nr. No.	Betegnelsen Bezeichnung	Designation Désignation	4203KB	45C3-03
71	6100602	Spændering Retaining ring Spanning Flaque AV pompe		1	1
72	1800465	Møtrik M10 Nut Mutter Ecrou		8	8
75	3001179	O-ring O-ring O-Ring Joint torique		1	1
76	6100984	Bøsning Bushing Buchse Manchon		1	1
81	1802602	Kraterskrue Crater-point screw Kraterschraube Vis		1	1
83	3000460	O-ring O-ring O-Ring Joint torique		1	1
85	6101784	Ventilkegle, komplet Valve cone, complete Ventilkegel, komplett Cône p. clapet, compl.		1	1
86	2600286	Fjeder Spring Feder Ressort		1	1
87	6100925	Stempel, kompl. Piston, compl. Kolben, komplett Piston, compl.		1	1
88	6101061	Stempelring Piston ring Kolbenring Anneau piston		1	1
89	3001716	O-ring O-ring O-Ring Joint torique		1	1
90	6101069	Seegerring Seeger circlip ring Seeger-Ring Anneau Seeger		1	1
91	6301392	Ring Ring ø 160 Ring Anneau	C3	1	
92	6100996	Styrestift Guide pin Kegelstift Goupille		1	1
93	6101042	Ventildæksel Valve cover Ventildeckel Corp by-pass		1	1
95	1603422	Ligeforskrøning Threaded connection Verschraubung Raccord fileté		1	
-	1602606	Ligeforskrøning Threaded connection Verschraubung Raccord fileté		1	
96	6100985	Låseskive Lock washer Sicherungsscheibe Disque de blocage		1	1
97	1802636	Skrue Screw Schraube Vis		1	1
98	1602333	Rørprop Pipe plug Rohrschlusstück Bouchon de tuyau		2	2

Pos. Ref.	Nr. No.	Betegnelsen Bezeichnung	Designation Désignation	4203KB	45C3-03
104	6100940	Justerskrue Adjustment screw Justierschraube Vis de réglage		1	1
105	6100928	Kontramøtrik Lock nut Gegenmutter Ecrou contre		1	1
106	6101752	Slangestuds, vinkel Hose socket, elbow Schlauchstutzen, Winkel Raccord de flexible, coude		1	1
107	6101753	Omløbsventil, komplet By-pass valve, compl. Umlaufventil, komplett Soupape by-pass, compl.		x	x
108	3000064	O-ring O-ring O-Ring Joint torique		1	1
109	6101018	Studs f. lynkobling Socket f. quick coupling Stutzen f. Schnellkupplung Raccord rapide		1	1
110	1801075	Tætningsskive Sealing washer Dichtungsscheibe Rondelle		1	1
111	6101038	Stempel-kontraventil Piston-nonreturn valve Kolben-Rückschlagventil Piston clapet anti-retour		1	1
112	1600493	Lynkoblingsnippel Quick coupling nipple Schnellkupplungsnippel Raccord rapide mâle		1	1
112	1603101	Lynkoblingsnippel, RF Quick coupling nipple, SS Schnellkupplungsnippel, RF Raccord rapide mâle, INOX		1	1
A ₂	1119568	Rep.sæt, pakninger f. omløbsv. Kit, gaskets f. by-pass v. Rep.satz, Dichtungen f. Umlaufventil Kit de joints p. soupape by-pass	03-C3		x
E	1118538	Rep.sæt, greb f. omløbsventil Kit, adj. mechanism, by-pass Satz, Justiereinrichtung f. Umlaufventil Kit, bouton de soupape by-pass		x	x
F	1118520	Rep.sæt, omløbsventil Rep.kit, by-pass valve Rep.satz, Umlaufventil Kit, soupape by-pass		x	x
G	1118512	Rep.sæt, sikkerhedsventil Rep.kit, safety valve Rep.satz, Überdruckventil Kit, soupape de sûreté		x	x

