

N/G- 4102/4502/4802

Reservedelsliste
Spare parts list
Ersatzteilliste
Liste de pièces détachées

Karosse / Body / Karosserie / Carrosserie	2
Pumpe / Pump / Pumpe / Pomp	9
Motor 4002A / Motor (4002A) / Motor (4002A) / Moteur (4002A)	13
Oliefyr/kedel / Oliburner/boiler / Ölbrenner/Kessel / Brulerur/chaudière	18
Kedel/spiral / Boiler/heating coil / Kessel/Spirale / Chaudière/serpentin	23
EI-komponenter (4001A/4002A Date < 11.01.2002) / Electric components (4001A/4002A Date < 11	25
EI-komponenter (4002A Date > 11.01.2002) / Electric components (4002A Date > 11.01.2002) / Ele	28
Pistol / Pistol / Pistole / Pistolet	31
Spulerør / Lances / Lanzen / Lance	33

Karosserie / Body / Carrosserie

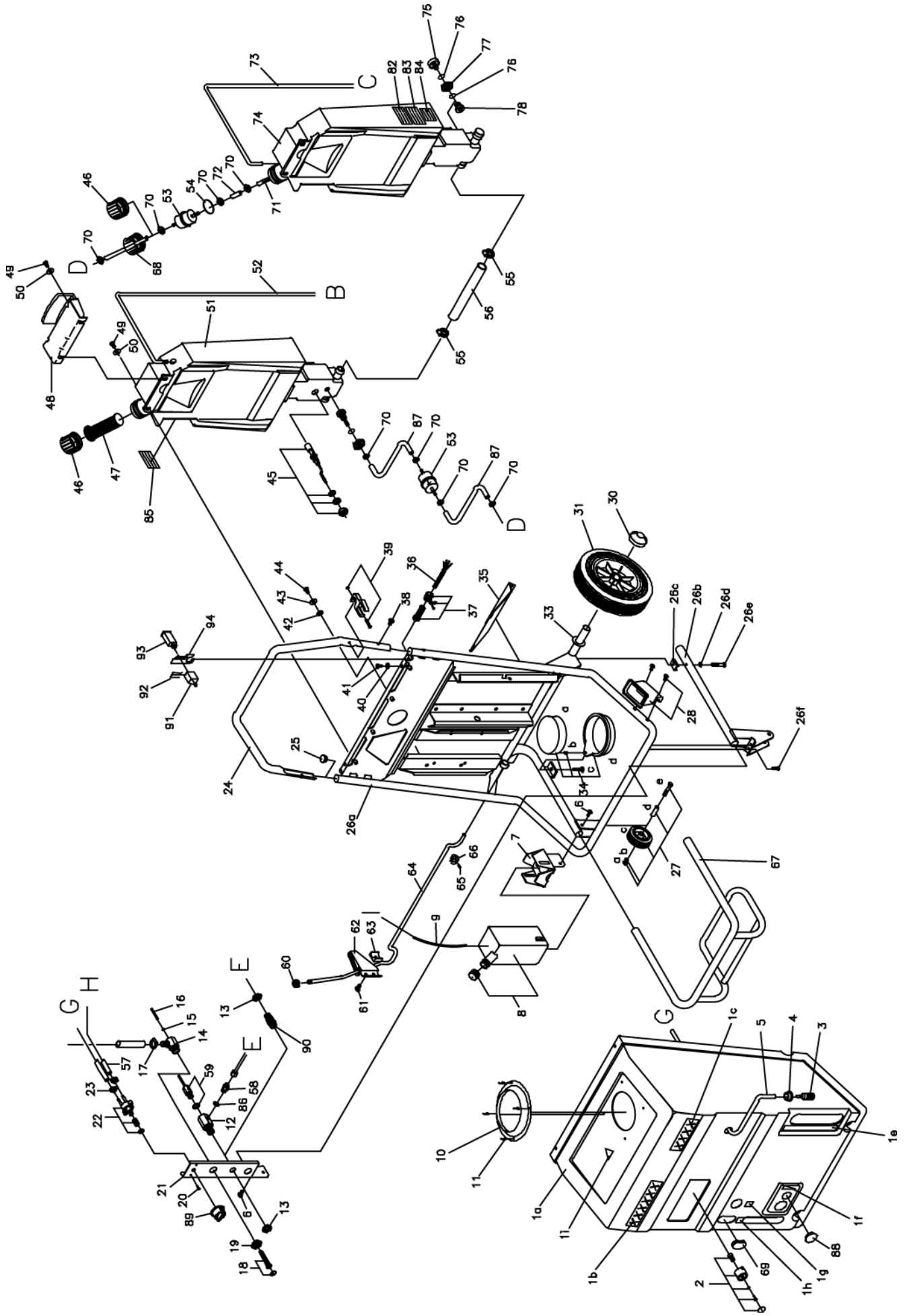

Karosseri / Body / Karosserie / Carrosserie

Pos.	Ref. no.	Betegnels Description	Bezeichnung Description	4102 A	4502 A	4802 A
0	06120506	GUMMIPAKNING F. NIVEAUFØL RUBBER GASKET FOR LEVEL PROTECTOR	DICHTUNG F. NIVEAUKONT. JOINT POUR CONTROLE DE NI	1	1	1
0	06160074	EL-STIK, 10AMP-380V *DK ELECTRIC PLUG, 10AMP-380V *DK	EL-STECCKER STOFFEST GRUEN/ROT *DK PRISE EL-RESISTANT AU CHOC *DK	1	1	1
0	06160352	EL-STIK, *DK ELECTRIC PLUG, *DK	EL-STECCKER M. ERDLEITER STOFFEST PRISE ELECTRIQUE DE TERRE MALE	1		
0	06160654	EL-STIK, *D CEE16 ELECTRIC PLUG, *D CEE16	EL-STECCKER FINLAND BREMSER. TYP1302 PRISE ELEC. FINLANDE PONY TYPE 1302	1		
01A	06240297	KAROSSE GRØN, 4002 BODY GREEN, 4002	CARROSSERIE VERTE S4002A	1	1	1
01A	06240298	KAROSSE GRÅ, 4002 BODY GREY, 4002	CARROSSERIE GRISE S4002A	1	1	1
01B	06302002	TRANSFERS N-4102A TRANSFERS N-4102	KLEBSTREIFEN N4102A AUTOCOLLANT N-4102A	1		
01B	06302004	TRANSFERS, N4502A TRANSFERS, N4502A	KLEBSTREIFEN N4502A AUTOCOLLANT, N4502A		1	
01B	06302005	TRANSFERS N-4802 TRANSFERS N-4802A	KLEBSTREIFEN N4802A AUTOCOLLANT N-4802A			1
01C	06301997	TRANSFERS, G4102A TRANSFERS, G4102A	KLEBSTREIFEN G4102A AUTOCOLLANT, G4102A	1		
01C	06301999	TRANSFERS, G4202A TRANSFERS, G4202A	KLEBSTREIFEN G4502A AUTOCOLLANT G 4502A		1	
01C	06302000	TRANSFERS, G4802A TRANSFERS, G4802A	KLEBSTREIFEN G4802A AUTOCOLLANT G4802 A			1
01F	06301564	TRANSFERS, SUPERTRIN TRANSFERS, SUPERTRIN	KLEBSTREIFEN AUTOCOLLANT ETAGE VAPEUR NG-4000	1	1	1
01G	06301764	TRANSFERS - OLJEKANDE TRANSFERS - OIL CAN	ETIKETT OELKANNE AUTOCOLLANT	1	1	1
01H	06301763	TRANSFERS - AFKALKNING TRANSFERS - WATER SOFTENING	ETIKETT ENTKALKUNG AUTOCOLLANT	1	1	1
01I	06301762	TRANSFER - ADVARSEL-HÅND TRANSFERS - WARNING-HAND	ETIKETT DREIECK HAND AUTOCOLLANT	1	1	1
02	06261769	PLASTKNAPKIT BUTTON KIT, PLASTIC	KIT F. PLASTIK KNOPE KIT POUR BOUTON EN	2	2	2
03	06100355	FILTER F. RENGØRINGSMIDDEL FILTER FOR DETERGENT	FILTER F. REINIGUNGSMITTEL FILTRE G-4000	1	1	1
04	06120380	STOPRING FOR KEMI, Ø30X11 STOP RING FOR DETERGENT, Ø30X11	STOPRING F. REINIGUNGSMITTEL ANNEAU ARRETNT NT	1	1	1
05	06110423	KEMISLANGE, 1/4" X 1450 MM DETERGENT HOSE, 1/4" X 1450 MM	REINIGUNGSMITTELSCHLAUCH, AUSSEN G-600 TUYAU	1	1	1
06	06070394	SKRUE, 8X16 SCREW, 8X16	TAPTITTE 6KT GALV. VIS	4	4	4
07	06061294	BESLAG FOR DUNK AFKALKING FITTINGS FOR TANK DECALCIFICATION	BESCHALG F. TANK ENTKALKUNG ARMATURE P.RESERV.DECALCIFICATION	1	1	1

Karosserie / Body / Carrosserie

Pos.	Ref. no.	Betegnelse Description	Bezeichnung Description	4102 A	4502 A	4802 A
08	06261764	ANTIKALEHOLDER MLÅG BOTTLE W. COVER	BEHÄLTER MIT DECKEL RESERVOIR	1	1	1
09	06110354	PLASTSLANGE, Ø3X900 PLASTIC HOSE, Ø3X900	PLASTIKSCHLAUCH F. ENTKALKUNG BRIDE EN PLASTIQUE	1	1	1
10	06061367	AFDÆKNING FOR SKORSTEN COVERING FOR CHIMNEY	ABDECKUNG FÜR SCHORNSTEIN G4001 COUVERCLE POUR CHEMINÉE	1	1	1
11	06070818	POPNIITTE, RUSTFRI, 4X9,5 TUBULAR RIVET, STAINLESS, 4X9,5	POPMUTTER RIVET G-4000/ACIER /ACIER	4	4	4
12	06181106	AFGANGSSTUDS, 32X74 OUTLET SOCKET, 32X74	VERSCHRAUBUNG RACCORD SORTIE HP G4000	1	1	1
13	06190062	MØTRIK, 27X10 NUT, 27X10	GEGENMUTTER CONTRE-ECROU LAITON M22 X	1	1	1
14	06211507	TILGANGSSTUDS, KPL. INLET SOCKET, CPL.	EINLASSTUTZEN KPL. RACCORD CPL. G-4000	1	1	1
15	06110494	SPÆNDEBAND, 10-12 RETAINING RING, 10-12	SCHLAUCHSCHELLE FRETTE	1	1	1
16	06110530	ARMERET PLASTSLANGE, 1/4" X 1610 MM ARMOURED PLASTIC HOSE, 1/4" X 1610 MM	ARMERTER PLASTIK SCHLAUCH TUYAU EN PLASTIQUE ARME NG-4000	1	1	1
17	06110471	SPÆNDEBAND, 14-32 RETAINING RING, 14-32	SCHLAUCHSCHELLE HS12 FRETTE	1	1	1
18	06261523	KIT FOR VANDFILTER KIT FOR WATER FILTER	KIT F. WASSERFILTER KIT P.FILTRE D'EAU G-4000	1	1	1
19	06181129	MØTRIK, 36X8 NUT, 36X8	GEGENMUTTER ECROU G-3000	1	1	1
20	06070752	SELVSKÆRENDE SKRUE, 3,5X13 SELF-TAPPING SCREW, 3,5X13	SCHNEIDSCHRAUBE, SCHWARZZINK VIS DE COUPE	2	2	2
21	06061224	PLADE FOR TIL-/AFGANG, 355X119,5X2,0 PLATE FOR INLET/OUTLET, 355X119,5X2,0	PLATTE F. EINLASS/AUSLASS PLAQUE P. ENTREE/DEPART	1	1	1
22	06211201	PLASTVENTIL KOMPLET PLASTIC DETERGENT VALVE CPL.	PLASTIK REINIGUNGSMITTELVENTIL KPL. VANNE PLASTIQUE G-2000/60ST. CPL.	1	1	1
23	06110494	SPÆNDEBAND, 10-12 RETAINING RING, 10-12	SCHLAUCHSCHELLE FRETTE	2	2	2
24	06051054	KØREHANDTAG, Ø25X2X OPERATION HANDLE, Ø25X2X	POIGNÉ, □25X2X	1	1	1
25	06200064	DUPSKO, 25 CAP, 25	KAPPE BOUT	2	2	2
26A-F	06211405	STEL, KPL., 4000 FRAME, CPL., 4000	GESTELL CADRE	1	1	1
26B	06211599	RØR FOR STEL PIPE FOR FRAME	TUYAU P. CADRE	1	1	1
26C	06200103	AFSTANDSSTYKKE DISTANCE PIECE	ZWISCHENSTUECK ENTRETOISE	1	1	1
26D	06080004	SPÆNDESKIVE, 8,4X17X1,6 TENSION DISC, 8,4X17X1,6	FEDERSKIBE, GALV. RONDELLE	1	1	1

Karosserie / Body / Karosserie / Carrosserie

Pos.	Ref. no.	Betegnelse Description	Bezeichnung Description	4102 A	4502 A	4802 A
26E	06070747	SÆTSKRUE, M8X45 SET SCREW, M8X45	VIS D'ARRET, M8X45	1	1	1
26F	06070832	TAP TITE, M6X12 TAP TITE, M6X12	TAPTITE	2	2	2
27	06261525	NÆSEHJUL KPL. NOSEWHEEL CPL.	BUGRAD KPL. ROUE POUR G-4000	2	2	2
27A	06080141	MØTRIK, M8 NUT, M8	MUTTER ECROU	1	1	1
27B	06080004	SPÆNDESKIVE, 8,4X17X1,6 TENSION DISC, 8,4X17X1,6	FEDERSKEIBE, GALV. RONDELLE	1	1	1
27C	06130206	HJUL, Ø80X35 WHEEL, Ø80X35	RAD ROUE G-4000	1	1	1
27D	06050933	BØSNING, Ø12X1,5X35,5 SLEEVE, Ø12X1,5X35,5	BUCHSE DOUILLE	1	1	1
27E	06070807	SKRUE, 8X55 SCREW, 8X55	BOLZEN BOULON	1	1	1
28	06261766	HOLDER FOR SPULERØR HOLDER FOR LANCE	HALTER F. LANZE SUPPORT DE LANCE	1	1	1
30	06280200	LÅSESKIVE, Ø25 LOCK WASHER, Ø25	ENJOLIVEUR ROUE	2	2	2
31	06130222	HJUL, 25/65-275/70 WHEEL, 25/65-275/70	ROUE PLEINE DURE	2	2	2
32	06110494	SPÆNDEBÅND, 10-12 RETAINING RING, 10-12	SCHLAUCHSCHELLE FRETTE	1	1	1
33	06080075	SPÆNDESKIVE, 45X25,5X1,5 TENSION DISC, 45X25,5X1,5	FEDERSKEIBE F. RAD, GALV. RONDELLE DE SERRAGE POUR ROUE	2	2	2
35	06061287	FODPLADE, 190X200X1,5 BASEPLATE, 190X200X1,5	GRUNDPLATTE PLAQUE	1	1	1
36	06160156	TILGANGSKABEL GUMMI, 4X1,5X8000 INLET CABLE RUBBER, 4X1,5X8000	GKSOJ-HAUPTKABEL CABLE ALIMENTAT.=160708	1	1	1
36	06160489	TILGANGSKABEL GUMMI, 4X2,5X8000 INLET CABLE RUBBER, 4X2,5X8000	KABEL HAUPTLEITUNG, SPANIEN CABLE PRINCIPAL, SPAIN	1		1
36	06160664	TILGANGSKABEL, GUMMI SPAN IEN	EINLASSKABEL GUMMI, SPANIEN CABLE D'ENTREE EN CAOUTCHOUC, L'ESPAGNE	1		
36	06160741	ELSTIK M. KABEL, PLAST. *GB ELECTRIC PLUG W. CABLE, PASTIC. *GB	STECKER M/PLASTIK KABEL UK PRISE ELECTRIQUE A. CABLE PLASTIQUE	1		
36	06160745	TILGANGSKABEL GUMMI, 3X1,5X8000 INLET CABLE RUBBER, 3X1,5X8000	EINLASSKABEL GUMMI CABLE D'ENTREE EN CAOUTCHOUC	1		
37	06261857	KABELGENNEMFØRINGSKIT, 3/4X1,5 CABLE GROMMET KIT, 3/4X1,5	KABELDURCHFÜHRUNGSKIT KIT DE TRAVERSEE DE CABLE	1	1	1
37	06261858	KABELGENNEMFØRINGSKIT, 3/4X2,5 CABLE GROMMET KIT, 3/4X2,5	KABELDURCHFÜHRUNGSKIT KIT DE TRAVERSEE DE CABLE, 3/4X2,5	1	1	1
37	06261859	KABELGENNEMFØRINGSKIT, 3/4X4,0 CABLE GROMMET KIT, 3/4X4,0	KIT DE TRAVERSEE DE CABLE, 3/4X4,0	1		1

Karosserie / Body / Karosserie / Carrosserie

Pos.	Ref. no.	Bezeichnung Description	4102 A	4502 A	4802 A
38	06070287	SÆTSKRUE, M8X20 SET SCREW, M8X20	2	2	2
39	06261765	HOLDER FOR PISTOL KPL. HOLDER FOR PISTOL	1	1	1
40	06080016	SPÆNDESKIVE, 6 MM TENSION DISC, 6 MM	2	2	2
41	06070435	SKRUE, M6X16 SCREW, M6X16	2	2	2
42	06080214	GUMMISKEIVE, Ø20XØ8X1,5 RUBBER DISC, Ø20XØ8X1,5	4	4	4
43	06080221	SPÆNDESKIVE, M8 TENSION DISC, M8	4	4	4
44	06070806	SÆTSKRUE, M8X35 SET SCREW, M8X35	4	4	4
45	06261666	NIVEAUFØLER LEVEL CONTROL	1	1	1
46	06200271	KAPSEL M. HÆTTE, 60 MM JACKET W. CAP, 60 MM	2	2	2
47	06100353	FILTERSI, Ø44X80 1CN STRAINER, Ø44X80 1CN	1	1	1
48	06200444	SLANGEHOLDER HOSE HOLDER	1	1	1
49	06070454	UNBRACO SKRUE, M6X25 ALLEN SCREW, M6X25	4	4	4
50	06080157	SPÆNDESKIVE, M6 TENSION DISC, M6	4	4	4
51	06262360	BRÆNDSTOFTANK VENSTRE FUEL TANK LEFT C.P.L.	1	1	1
51	06262466	BRÆNDSTOFTANK V. KPL FUEL TANK LEFT C.P.L.	1	1	1
52	06110560	SLANGE, Ø9X900X45GR HOSE, Ø9X900X45GR	1	1	1
53	06230327	BRÆNDSTOFFILTER FUEL FILTER	1	1	1
55	06110206	SPÆNDEBÅND, 22-32 RETAINING RING, 22-32	2	2	2
56	06110567	TANKFORBINDELSLANGE SHAPED HOSE, 27 MM*MAX 235 MM	1	1	1
57	06110529	ARMERET PLASTSLANGE 1/4 X ARMOURED PLASTIC HOSE 1/4	1	1	1
57	06110532	ARMERET PLASTSLANGE , 860 MM ARMOURED PLASTIC HOSE , 860 MM	1	1	1
58	06030037	HYDRAULIKFORSKR. 3/8"-10/12 HYDRAULIC SCREWED CONNECTION, 3/8"-10/12	1	1	1

Karosserie / Body / Carrosserie / Carrosserie

Pos.	Ref. no.	Betegnelse Description	Bezeichnung Description	4102 A	4502 A	4802 A
59	06211276	TEMPERATURFØLER KPL., G6000 THERMAL PROTECTOR CPL., G6000	TEMPERATURWAECHTER KPL. DETECTEUR INTERNE DE TEMPERATURE CPL.	1	1	1
59A	06120188	O-RING, 10X2 O-RING, 10X2	O-RING JOINT TORIQUE	1	1	1
60	06200288	KUGLE, M10 Ø32 BALL, M10 Ø32	KUGEL, SCHWARZ BOULETTE(NTE) NTE)	1	1	1
62	06061277	BLANKET F. TIL-/AFGANGSPL ADE	PLATTE F. EINLASS-/AUSLASSPLATTE FLAN P. PLAQUE D'ENTREE/DEPART	1	1	1
63	06200103	AFSTANDSSTYKKE DISTANCE PIECE	ZWISCHENSTUECK ENTRETOISE	2	2	2
64	06040193	BREMSESTANG, Ø10X1000 4000 BRAKE LEVER , Ø10X1000 4000	BREMSESTAEENGE SABOT DE FREIN NG-4000	1	1	1
65	06070478	PINOLSKRUE, M6X8 POINTED SCREW, M6X8	REITSTOCKSCHRAUBE, ROSTFREI VIS	1	1	1
66	06181005	BØSNING, Ø25X22 SLEEVE, Ø25X22	BUCHSE F. BREMSE G-6000 MANCHON POUR FREINS G-6000	1	1	1
67	06211512	DUNKEHOLDER TANK HOLDER	TANKHALTER KPL. SUPPORT DETERGENT G-4000 NG-4000	1	1	1
69	06200454	GUMMIADFÆKNING RUBBER COVER	COUVERTURE EN CAOUTCHOUC G4001	1	1	1
70	06110609	SPÆNDEBAND, 13 RETAINING RING, 13	SHELLE FRETTE ABA13	2	2	2
73	06261645	BRÆNDSTOFSLANGE RETUR, KPL. FUEL HOSE RETURN, CPL.	OELSCHLAUCH ZURUECK TUYAU FUEL RETOUR CPLT	1	1	1
74-78	06261660	BRÆNDSTOFTANK, KPL. FUEL TANK, CPL.	BRENNSTOFFTANK RESERVOIR FUEL DROIT CPL.	1	1	1
75	06180579	BUNDFROP, Ø24X20 BOTTOM CAP, Ø24X20	BODENPFROPEN F. OELTANK PRISE SUPERIEURE DE RESERA FUEL	1	1	1
76	06120232	O-RING, 15X3 O-RING, 15X3	O-RING JOINT	2	2	2
77	06181288	MØTRIK NUT	MUTTER F. OELENTLEERUNG ECROU	1	1	1
78	06181287	NIPPEL NIPPLE	NIPPEL F. OELENTLEERUNG RACCORDE E	1	1	1
82	06301619	TRANSFER "ADVARSEL" TRANSFERS "WARNING"	TRANSFERS WAHRNUNG G-880 AUTOCOL. "AVERTISSEMENT"	1	1	1
83	06301097	TYPESKILT, 45X65 MM TYPE PLATE, 45X65 MM	TYPESCHILD GRAU AUTOCOLLANT G-480	1	1	1
84	06301663	TRANSFER "CE" TRANSFERS "CE"	TRANSFERS CE MARKE AUTOCOLLANT	1	1	1
85	06300495	TRANSFERS, 2000/3000 TRANSFERS, 2000/3000	KLEBESTREIFEN DIESELOEL AUTOCOLLANT HUILE DIESEL	1	1	1
86	06120531	KOBBERSKIVE, Ø22XØ17X1,5 COPPER DISC, Ø22XØ17X1,5	KUPFERSCHEIBE DISQUE EN CUIVRE DIA.22XDIA.17X1,5	1	1	1

Karosserie / Body / Karosserie / Carrosserie

Pos.	Ref. no.	Betegnelse Description	Bezeichnung Description	4102 A	4502 A	4802 A
87	06110673	BRÆNDSTOFSLANGE, 125 MM FUEL HOSE, 125 MM	TUYAU GAS OIL 4002A	2	2	2
88	06150186	AFDÆKNINGSPROP, Ø45 COVER PLUG, Ø45	CAPUCHON DE COUVERTURE, □45	1	1	1
89	06200548	PLASTKNAP PLASTIC BOTTON	BOUTON EN PLASTIQUE	1	1	1

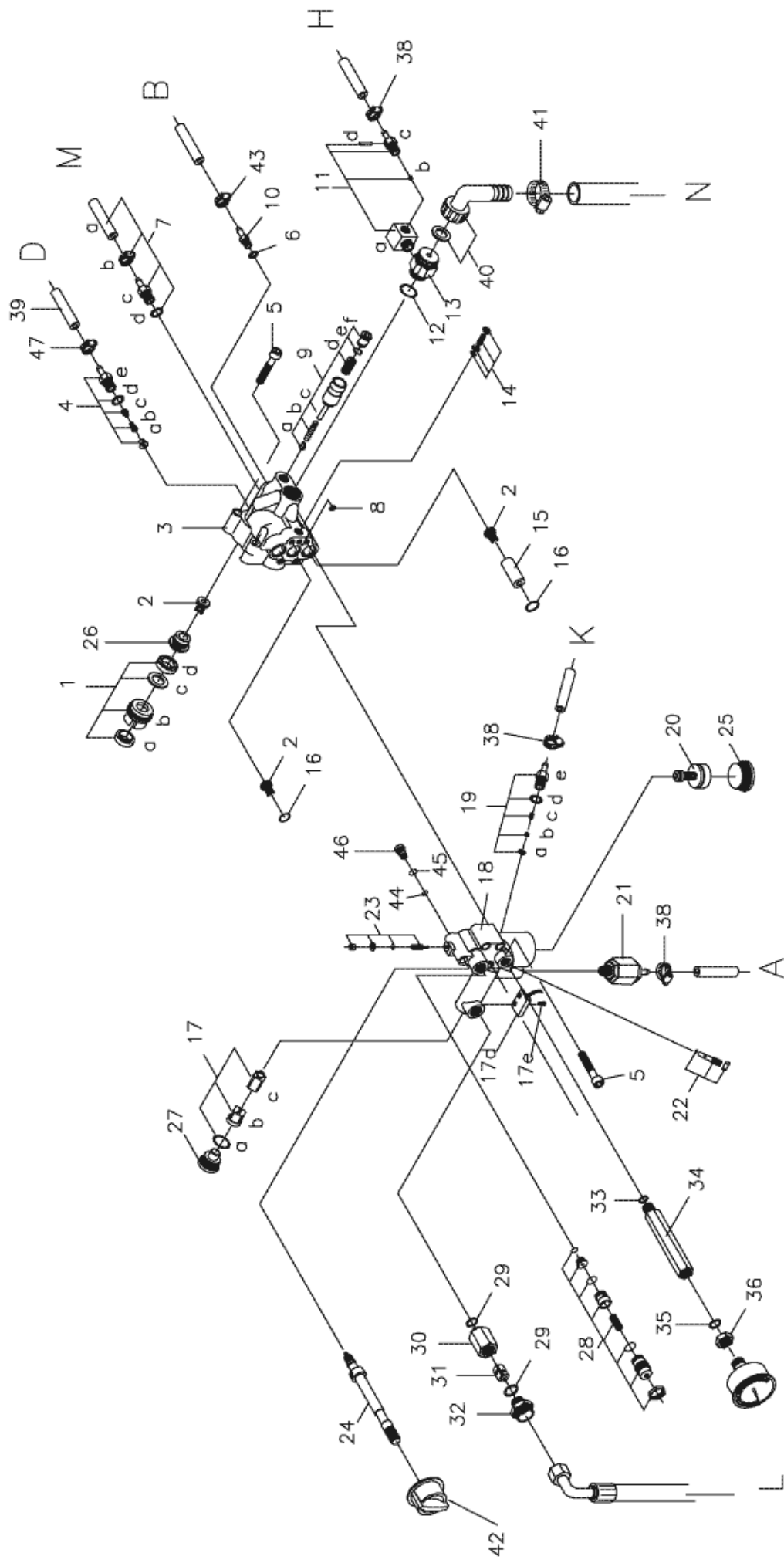

Pumpe / Pump / Pumpe / Pomp

Pos.	Ref. no.	Betegnelse Description	Bezeichnung Description	4102 A	4502 A	4802 A
01	06261489	KIT FOR MANCHET KIT FOR CUP	KIT F. MANSCHETTE KIT P.COUPELLE G-310/350/	1	1	1
02	06261599	VENTILKIT KIT FOR VALVE, 880 50/60 HZ	KIT VENTILE KIT CLAPETS	1	1	1
03	06181031	TOPSTYKKE, 4000 CYLINDER HEAD, 4000	ZYLINDERKOPF CULASSE	1	1	1
04	06261537	SUGESTUDS OLIEPUMPE KPL. SUCTION SOCKET OIL PUMP	SAUGSTUTZEN OELPUMPE RAC.ASPI.POMPE GAS-OIL CPE A GAS-OIL CPL	1	1	1
05	06070451	UNBRACO SKRUE, M8X45 ALLEN SCREW, M8X45	IMBUSSBOLZEN, GALV. INTRAVIS GALV. GALV.	8	8	8
07	06261644	BRÆNDSTOFSLANGE TILGANG, KPL. FUELHOSE INLET, CPL.	OELSCHLAUCH EINLASS TUYAU ENTREE FUEL	1	1	1
07B	06110494	SPÆNDEBÅND, 10-12 RETAINING RING, 10-12	SCHLAUCHSCHELLE FRETTE	1	1	1
09	06261535	JUSTERSKRUE OLIEPUMPE ADJUSTING SCREW OIL PUMP	JUSTIERSCHRAUBE OELPUMPE VIS REGL.POMPE GAS-OIL G-S-OIL	1	1	1
09F	06181063	JUSTERSKRUE, M14X16,5 ADJUSTING SCREW, M14X16,5	JUSTIERSCHRAUBE OELMESSSTAB VIS DE REGLAGE BOUCHON G-4000	1	1	1
1 - 34	06360617	PUMPE, KPL. M. SUPERTRIN, G4102A 50-60 HZ PUMP, CPL. W. STREM DEVICE, G4102A 50-60 HZ	POMPE, CPL. A.ETAGES SUPER, G4102A 50-60 HZ	1		
1 - 34	06360618	PUMPE, KPL. M. SUPERTRIN, G4502A 50-60 HZ PUMP, CPL. W. STREM DEVICE, G4502A 50-60 HZ	POMPE, CPL. A.ETAGES SUPER, G4502A 50-60 HZ		1	
1 - 34	06360619	PUMPE, KPL. M. SUPERTRIN, G4802A 50-60HZ PUMP, CPL. W. STREM DEVICE, G4802A 50-60HZ	POMPE, CPL. A.ETAGES SUPER, G4802A 50-60HZ			1
1 - 34	06360620	PUMPE, KPL. U. SUPERTRIN, G4102A 50-60HZ PUMP, CPL. W.O. STREM DEVICE, G4102A 50-60HZ	POMPE, CPL. S.ETAGES SUPER, G4102A 50-60HZ	1		
1 - 34	06360621	PUMPE, KPL. U. SUPERTRIN, G4502A 50-60HZ PUMP, CPL. W.O. STREM DEVICE, G4502A 50-60HZ	POMPE, CPL. S.ETAGES SUPER, G4502A 50-60HZ		1	
1 - 34	06360622	PUMPE, KPL. U. SUPERTRIN, G4802A 50-60HZ PUMP, CPL. W.O. STREM DEVICE, G4802A 50-60HZ	POMPE, CPL. S.ETAGES SUPER, G4802A 50-60HZ			1
1+2	06261717	KIT FOR PUMPE, 60 HZ 4000 KIT FOR PUMP, 60 HZ 4000	PUMPEKIT G4000 60HZ KIT POMPE G-4000	1	1	1
10	06181062	STUDS, 13X33 SOCKET, 13X33	RUECKSTUTZEN OELPUMPE RACCORDA GAS-OIL A GAS-OIL	1	1	1
11	06261536	RETURNSTUDS, KPL. RETURN SOCKET, CPL.	REINIGUNGSMITTELSTUTZEN KPL. RACCORD DE DETERGENT CPL.	1	1	1
13	06181037	SUGEKLODS, 27X32 SUCTION BLOCK, 27X32	SAUGKLOTZ BLOC D'ASPIRATION	1	1	
13	06181220	SUGEKLODS, 27X32 SUCTION BLOCK, 27X32	SAUGKLOTZ BLOC D'ASPIRATION			1
14	06261131	JUSTERSKRUE ADJUSTING SCREW	JUSTIERSCHRAUBE F. MANOMETERDRUCK VIS REGLAGE PRESS.OUVERT.N D'OUVERTURE	1	1	1
15	06181033	AFSTANDSSTYKKE, Ø15,3X37,5 DISTANCE PIECE, Ø15,3X37,5	ZWISCHENSTUECK PIECE INTERMEDIAIRE	2	2	2

Pumpe / Pump / Pumpe / Pomp

Pos.	Ref. no.	Betegnelse Description	Bezeichnung Description	4102 A	4502 A	4802 A
17	06261533	FLOWSTYRING KPL., 4000 FLOW CONTROL CPL., 4000	STROEMUNGSWAECHTER KPL. GUIDE DE FLOW CPL. G-4000	1	1	1
17B	06211353	FLOWSTEMPEL KPL. FLOW PISTON CPL.	STROEMUNGSKOLBEN KPL. PISTON DE FLOW	1	1	1
17C	06211354	KONTRAVENTIL FLOW KOMPL. NON-RETURN VALVE FLOW CPL., G-4000	RUECKSCHLAGVENTIL STROEMUNG KPL. VANNE ANTIRETOUR FLOW CPL.	1	1	1
17D	06170240	REED-KONTAKT, 850 MM REED-SWITCH, 850 MM	INTERRUPTEUR REED G880	1	1	1
17E	06070736	SKRUE, 3X6 SCREW, 3X6	SCHRAUBE P/K VIS	2	2	2
18	06181248	TRYKMANIFOLD PRESSURE MANIFOLD	DRUCKMANIFOLD COLLECTEUR PRES.4000/4001	1	1	1
18	06181315	TRYKMANIFOLD PRESSURE MANIFOLD	DRUCKMANIFOLD CULASSE	1	1	1
19	06261534	UDLUFINGSSTUDS, 4000 SOCKET FOR AIR ESCAPE COCK, 4000	ENTLUFTUNGSSTUTZEN RACCORD DE PURGE G-4000	1	1	1
20	06261485	OMLØBSVENTILKIT KIT FOR BY-PASS VALVE, G300/400/4000	KIT F. UMLAUFVENTIL KIT VAN. BY-PASS G310/350/	1	1	1
21	06261538	KIT FOR TILGANGSSTUDS KIT FOR INLET SOCKET, 4000	RUECKSCHLAGVENTIL KPL. VANNE ANTIRETOUR CPL. G-4	1	1	1
22	06261488	JUSTERSKRUE OMLØB ADJUSTING SCREW - BY-PASS	STELLSCHRAUBE - UMLAUF VIS REGLAGE BY-PASSL. L.	1	1	1
24	06262368	SUPERTRINSKIT, 4102/4502 STEAM DEVICE KIT, 4102/4502	DAMPFSTUFE KIT G4102/4502 KIT P. ETAGE SUPER, 4102/4502	1	1	1
24	06262369	SUPERTRINSKIT, 4802 STEAM DEVICE KIT, 4802	DAMPFSTUFE KIT G4802 KIT P. ETAGE SUPER, 4802			1
25	06181039	PROP FOR OMLØB, Ø38X17 PLUG FOR BY-PASS, Ø38X17	PFROPFEN F. UMLAUF CAPUCHON POUR BY-PASS	1	1	1
26	06181032	STØTTEBØSNING, Ø25.8X16 SUPPORTING SLEEVE, Ø25.8X16	STUETZBUCHSE BAGUE DE SUPPORT	3	3	3
27	06181130	PROP FOR AFGANG, Ø26X24 PLUG FOR OUTLET, Ø26X24	PFROPFEN F. AUSSLASS - DRUCKMANIFOLD CAPUCHON DE DEPART	1	1	1
28	06261740	SIKKERHEDSVENTIL KIT FOR SAFETY VALVE, 3/400/880/4000 MRK 2	SICHERHEITSVENTILKIT KIT VANNE DE SURETE	1	1	1
29	06120282	O-RING, 14X1,78 O-RING, 14X1,78	O-RING JOINT TORIQUE 14 X 1,78	2	2	2
30	06181162	HUS FOR TILBAGESLAGSVENTIL, 22X44,5 HOUSING FOR NON-RETURN VALVE, 22X44,5	GEHAUSE F. RUECKSCHLAGVENTIL CORPS POUR VANNE DE CONTRE-COUP	1	1	1
31	06180960	DRØVELVENTIL FOR FLOWST. THROTTLER VALVE FOR FLOW CONTROL, 11X11X18,8	DROSSELVENTIL F. STROEMUNGSKONTROLLE SOUPAPE RENIFL.P.COND.FLOONDUITE DE FLOW	1	1	1
32	06030757	FORSKRUNING, 3/8" SCREWED CONNECTION, 3/8"	HYDRAULIKVERSCHRÄUBUNG KIT JOINT TUYAU CUIVRE +	1	1	1
33	06120267	O-RING, Ø10.82X1,78 O-RING, Ø10.82X1,78	O-RING JOINT	1	1	1

Pumpe / Pump / Pumpe / Pump

Pos.	Ref. no.	Bezeichnung Description	4102 A	4502 A	4802 A
34	06181547	MANOMETERSTUDS, 4102/4502 PRESSURE GAUGE SOCKET, 4102/4502	1	1	
34	06181548	MANOMETERSTUDS, 4802 PRESSURE GAUGE SOCKET, 4802			1
35	06120309	O-RING, 4,47X1,78 O-RING, 4,47X1,78	1	1	1
37	06220056	MANOMETER, BAR/PSI PRESSURE GAUGE, BAR/PSI	1	1	1
38	06110494	SPÆNDEBÅND, 10-12 RETAINING RING, 10-12	3	3	3
39	06080246	MØTRIK FOR MANOMETER, 1/8 NUT F. PRESSURE GAUGE, 1/8	1	1	1
39	06110673	BRÆNDSTOFSLANGE, 125 MM FUEL HOSE, 125 MM	1	1	
40	06030681	VINKELSTUDS, 3/4" ANGLE SOCKET, 3/4"	1	1	1
41	06110471	SPÆNDEBÅND, 14-32 RETAINING RING, 14-32	1	1	1
42	06200548	PLASTKNAP PLASTIC BOTTON	1	1	1
43	06110564	SPÆNDEBÅND RETAINING RING	2	2	2
44	06120087	O-RING, 5,28X1,78 O-RING, 5,28X1,78	1	1	1
45	06120446	O-RING, 7,66X1,78 70 O-RING, 7,66X1,78 70	1	1	1
46	06181325	SÆDE FOR DAMPTRIN, Ø12.5X17 SEAT FOR STEAM DEVICE, Ø12.5X17	1	1	1
47	06110609	SPÆNDEBÅND, 13 RETAINING RING, 13	1	1	1

Motor 4002A / Motor (4002A) / Motor (4002A) / Moteur (4002A)

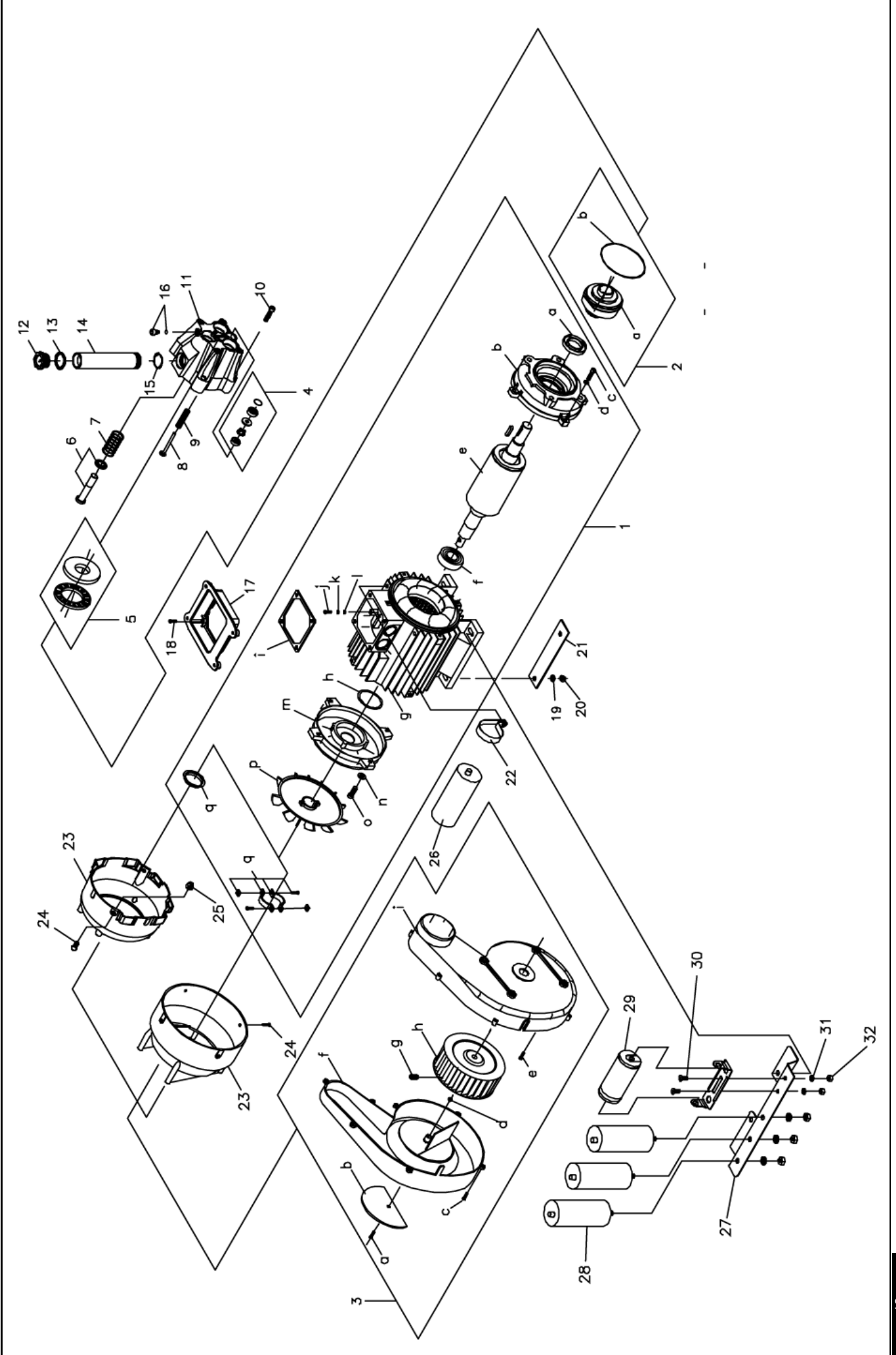

Motor 4002A / Motor (4002A) / Motor (4002A) / Moteur (4002A)

Pos.	Ref. no.	Betegnelse Description	Bezeichnung Description	4102 A	4502 A	4802 A
01	06360623	MOTOR KPL., G4102 1X110V 50HZ MOTOR CPL., G4102 1X110V 50HZ	MOTEUR CPL., G4102 1X110V 50HZ	1		
01	06360624	MOTOR KPL., G4102 1X230/240V 50HZ MOTOR CPL., G4102 1X230/240V 50HZ	MOTEUR G4102A 1X230 50HZ	1		
01	06360625	MOTOR KPL., G4102 1X230/240V 60HZ MOTOR CPL., G4102 1X230/240V 60HZ	MOTEUR CPL., G4102 1X230/240V 60HZ	1		
01	06360626	MOTOR KPL., G4502 3X200 50/60HZ MOTOR CPL., G4502 3X200 50/60HZ	MOTEUR CPL., G4502 3X200 50/60HZ		1	
01	06360627	MOTOR KPL., G4502 3X230-415V 50HZ MOTOR CPL., G4502 3X230-415V 50HZ	MOTEUR CPL., G4502 3X230-415V 50HZ		1	
01	06360628	MOTOR KPL., G4802 3X200V 50-60HZ MOTOR CPL., G4802 3X200V 50-60HZ	MOTEUR CPL., G4802 3X200V 50-60HZ			1
01	06360629	MOTOR KPL., G4802 3X230-415V 50HZ MOTOR CPL., G4802 3X230-415V 50HZ	MOTEUR CPL., G4802 3X230-415V 50HZ			1
01	06360630	MOTOR KPL., G4802 3X230-400V 60HZ MOTOR CPL., G4802 3X230-400V 60HZ	MOTEUR CPL., G4802 3X230-400V 60HZ			1
01A	06120575	PAKÅSE, Ø28/Ø47X7 STUFFING BOX, Ø28/Ø47X7	PRESSE-ETOUPE, □28/□47X7	1	1	1
01B	06181521	MOTORFLANGE MOTOR FLANGE	BRIDE DE MOTEUR	1	1	
01B	06181522	MOTORFLANGE, B100 MOTOR FLANGE, B100	BRIDE DE MOTEUR, B100			1
01C	06070796	SÆTSKRUE GALV	GEWINDESTIFT VIS D'ARRRET GALVANISEE	8	8	8
01D	06080016	SPÆNDESKIVE, 6 MM TENSION DISC, 6 MM	FEDERSKEIBE, GALV. RONDELLE DE SERRAGE	8	8	8
01E	06270403	ROTORAKSEL, 1X230V 50HZ 2.3KW H ROTOR AXLE, 1X230V 50HZ 2.3KW H	ARBRE DE ROTOR, 1X230V 50HZ 2.3KW H	1		
01E	06270404	ROTORAKSEL, 1X230V 60HZ 2.3KW H ROTOR AXLE, 1X230V 60HZ 2.3KW H	ARBRE DE ROTOR, 1X230V 60HZ 2.3KW H	1		
01E	06270405	ROTORAKSEL, 1X110V 50HZ 2,3 KW C H ROTOR AXLE, 1X110V 50HZ 2,3 KW C H	ARBRE DE ROTOR, 1X110V 50HZ 2,3 KW C H	1		
01F	06140039	KUGLELEJE BALL BEARING	KUGELLAGER 6205 ZZR.C3.L12 ROULEMENT 6205 G 600	1	1	
01F	06140040	KUGLELEJE, 8X7X35 BALL BEARING , 8X7X35	KUGELLAGER 6206 ZZR.C3.L12 ROULEMENT 6206 G 600			1
01I	06120542	PAKNING GASKET	DICHTUNG F. LEITERKASSE JOINT P. BOITE A BORNES	1	1	
01I	06120574	PAKNING GASKET	JOINT			1
01J	06070511	TAP TITE P/H, M4X8 TAP TITE P/H, M4X8	SCHRAUBE VIS 4X8 HFC 266	1	1	1
01K	06080046	STJERNESKIVE, M4 TOOTH LOCK WASHER, M4	STJERNESKEIBE, GALV. RONDELLE	1	1	1

Motor 4002A / Motor (4002A) / Motor (4002A) / Moteur (4002A)

Pos.	Ref. no.	Betegnelse Description	Bezeichnung Description	4102 A	4502 A	4802 A
01L	06080014	SPÆNDESKIVE, M4 TENSION DISC, M4	FEDERSCHEIBE, GALV. RONDELLE DE SERRAGE	1	1	1
01M	06270337	MOTORFLANGE MOTOR FLANGE	BRIDE DE MOTEUR	1	1	
01M	06270415	MOTORFLANGE, B100 MOTOR FLANGE, B100	BRIDE DE MOTEUR, B100			1
01N	06080016	SPÆNDESKIVE, 6 MM TENSION DISC, 6 MM	FEDERSCHEIBE, GALV. RONDELLE DE SERRAGE	8	8	8
01O	06070796	SÆTSKRUE GALV	GEWINDESTIFT VIS D'ARRRET GALVANISEE	8	8	8
01P	06270238	VENTILATORVINGE, FAN BLADE, PLAST	VENTILATORFLUEGEL AILETTE SOUFFLANTE G 350	1	1	
01P	06270416	VENTILATORVINGE FAN BLADE	AILETTE SOUFFLANTE			1
01Q	06270338	KOBLING, KPL. COUPLING, CPL.	ACCOUPELEMENT CPL.	1	1	
01Q	06270417	KOBLING, KPL. COUPLING, CPL.	ACCOUPELEMENT, CPL.			1
02	06262354	SKRÅKIVEKIT, 50 HZ CAM DISC KIT, 50 HZ	DISQUE INCLINE, KIT, 50 HZ	1		
02	06262355	SKRÅKIVEKIT, 60HZ CAM DISC KIT, 60HZ	DISQUE INCLINE, KIT, 60HZ	1		
02	06262356	SKRÅKIVEKIT, 50 HZ CAM DISC KIT, 50 HZ	DISQUE INCLINE, KIT, 50 HZ		1	
02	06262357	SKRÅKIVEKIT, 60HZ CAM DISC KIT, 60HZ	DISQUE INCLINE, KIT, 60HZ		1	
02	06262358	SKRÅKIVEKIT, 50 HZ CAM DISC KIT, 50 HZ	DISQUE INCLINE, KIT, 50 HZ			1
02	06262359	SKRÅKIVEKIT, 60HZ CAM DISC KIT, 60HZ	DISQUE INCLINE, KIT, 60HZ			1
02B	06120413	O-RING, 85X2,5 O-RING, 85X2,5	O-RING 70 GRAD JOINT TORIQUE	1	1	1
03	06262202	BLÆSERHUS KOMPL. IMPELLER HOUSING CPL.	CORPS SOUFFLANT 2300/2500	1	1	1
03A	06070879	SÆTSKRUE, M5X20 SET SCREW, M5X20	VIS D'ARRRET, M5X20	1	1	1
03B	06230368	SPJÆLD FOR BLÆSERHUS DAMPER FOR IMPELLER HOUSING	CLEFOR P. CORPS DE SOUFFLANTE	1	1	1
03C	06070866	SKRUE, 3,5X12 SCREW, 3,5X12	SCHRAUBE VIS POUR 230/250	7	7	7
03D	06080084	MØTRIK, M5 NUT, M5	MUTTER, GALV. ECROU GALVANISE	1	1	1
03E	06070878	PLASTTITE, M5X20 PLASTITE, M5X20	PLASTITE, M5X20	4	4	4

Motor 4002A / Motor (4002A) / Motor (4002A) / Moteur (4002A)

Pos.	Ref. no.	Betegnelse Description	Bezeichnung Description	4102 A	4502 A	4802 A
03F	06230369	BLÆSERHUS OVERPART BURNER HOUSING UPPER PART	CORPS ROUE SOUFFLANTE2000	1	1	1
03G	06070163	UNBRACO SKRUE, M8X12 ALLEN SCREW, M8X12	IMBUSSBOLZEN VIS PIVOT 8 X 12	1	1	1
03H	06230372	BLÆSERHJUL, Ø146X52 IMPELLER WHEEL, Ø146X52	ROUE SOUFFL.4102/502/802	1	1	1
03I	06230370	BLÆSERHUS UNDERPART BURNER HOUSING UNDER PART	CORPS ROUE SOUFFLANTE2000	1	1	1
04	06261709	MANCHETKIT FOR OLIEPUMPE, NG4000 MRK II CUP KIT FOR OIL PUMP, NG4000 MRK II	KIT FUR MANSCHETTE ÖLPUMP KIT RONDELLE POMPE GASOIL	1	1	1
05	06261684	KIT FOR TRYKLEJE, 350/400/4000 KIT FOR THRUST BEARING, 350/400/4000	DRUCKLAGERKIT ROULEMENT DE G. 350 (R.062)	1	1	1
06	06261504	STEMPELKIT 1 STK., G-300/400/4000 PISTON KIT 1 PCS., G-300/400/4000	KIT F. KOLBEN KPL. KIT PISTON CPL G310/350/4	3	3	3
07	06280143	TILHOLDERJEDER, 31X3,5X59 6,5V1 PRESSURE SPRING, 31X3,5X59 6,5V1	DRUCKFEDER RESSORT DE PRESSION	3	3	3
08	06262250	STEMPEL FOR OLIEPUMPE PISTON FOR OIL PUMP	PISTON POUR POMPE HUILE	1	1	1
09	06280144	FJEDER FOR OLIESTEMPEL, 15,5X1,5X55 9,5 SPRING FOR OIL PISTON, 15,5X1,5X55 9,5	RUECKGANGFEDER RESSORT PISTON HUILE G-40 G-4000	1	1	1
10	06070451	UNBRACO SKRUE, M8X45 ALLEN SCREW, M8X45	IMBUSSBOLZEN, GALV. INTRAVIS GALV.	4	4	4
11	06181557	STEMPELSTYR, MRK. III PISTON GUIDE, MRK. III	GUIDE PISTON, MRK. III	1	1	1
12	06120577	OLIEGLAS, 3/4" OIL GLASS, 3/4"	BOUCHON VER.HUILE=262469	1	1	1
13	06120580	PAKNING FOR OLIEØJE GASKET, Ø31XØ26X1,5	JOINT, Ø31XØ26X1,5	1	1	1
14	06181547	MANOMETERSTUDS, 4102/4502 PRESSURE GAUGE SOCKET, 4102/4502	RACCORD MANOMETRE 4102/45	1	1	1
14	06181555					1
15	06120051	O-RING, 25.3X2,4 O-RING, 25.3X2,4	O-RING JOINT TORIQUE	1	1	1
16	06261494	OLIEAFTAPNINGSPROP KPL., 3/400,881,4001 DRAIN PLUG CPL., 3/400,881,4001	OELABLASSTOPFEN KPL. CAPUCHON P.VID.G300/400IILL CPL.	1	1	1
17	06200537	MELLEFLANGE, G402 INTERMEDIATE FLANGE, G402	BRIDE, G402	1	1	1
18	06070893	SKRUE, 4,8X32 SCREW, 4,8X32	VIS, 4,8X32	4	4	4
19	06080004	SPÆNDESKIVE, 8,4X17X1,6 TENSION DISC, 8,4X17X1,6	FEDERSCHIBE, GALV. RONDELLE	4	4	4
20	06080038	MØTRIK, M8 NUT, M8	SELBSTSCHLIESSENDE MUTTER, GALV. ECROU	4	4	4

Motor 4002A / Motor (4002A) / Motor (4002A) / Moteur (4002A)

Pos.	Ref. no.	Betegnelse Description	Bezeichnung Description	4102 A	4502 A	4802 A
21	06120454	VIBRATIONSPLADE, 144X38X6 VIBRATION PLATE , 144X38X6	SCHWINGUNGSTAFEL PLAQUE DE VIBRATIONS G-410/350/460	2	2	
21	06120455	VIBRATIONSPLADE, 164X40X6 VIBRATION PLATE , 164X40X6	SCHWINGUNGSTAFEL PLAQUE DE VIBRATIONS G-480			2
22	06110672	HOLDER FOR CONDENSATOR, 110V/50 HZ FITTINGS FOR CONDENSATOR, 110V/50 HZ	ANNEAU POUR CONDENSATEUR, 110V/50 HZ	1		
23	06270367	VENTILATIONSDEKSEL, NICO FAN COVER, NICO	COUVERCLE A VENTILATION, NICO	1	1	
23	06270418	VENTILATIONSDEKSEL, G482 FAN COVER, G482	COUVERCLE A VENTILATION, G482			1
24	06070085	SÆTSKRUE, M8X16 SET SCREW, M8X16	SETZSCHRAUBE, GALV. VIS D'ARRET, GALVANISEE			4
24	06070778	SKRUE, 3,9X9,5 SCREW, 3,9X9,5	VIS, 3,9X9,5	4	4	
25	06080270	MØTRIK, M8 NUT, M8	ECROU, M8			4
26	06270413	KONDENSATOR, 55 ÅF CAPASITOR, 55 µF	CONDENSATEUR, 55 ÅF	1		
27	06061499	BESLAG FOR KONDENSATOR FITTINGS FOR CONDENSATOR	ARMATURE P. CONDENSATEUR	1	1	1
29	06270319	KONDENSATOR, 315-400 ÅF CAPASITOR, 315-400 µF	CONDENSATEUR, 315-400 ÅF	1		
30	06070742	SKRUE, 6X16 SCREW, 6X16	SCHRAUBE VIS 6X16 GALV.	2		
31	06080114	SKIVE, M6 WASHER, M6	STERNSCHEIBE RONDELLE A DENTS	5		
32	06080058	MØTRIK, M6 NUT, M6	MUTTER, GALV. ECROU	5		

Oliefyr/kedel / Oilburner/boiler / Ölbrenner/Kessel / Brulerur/chaudière

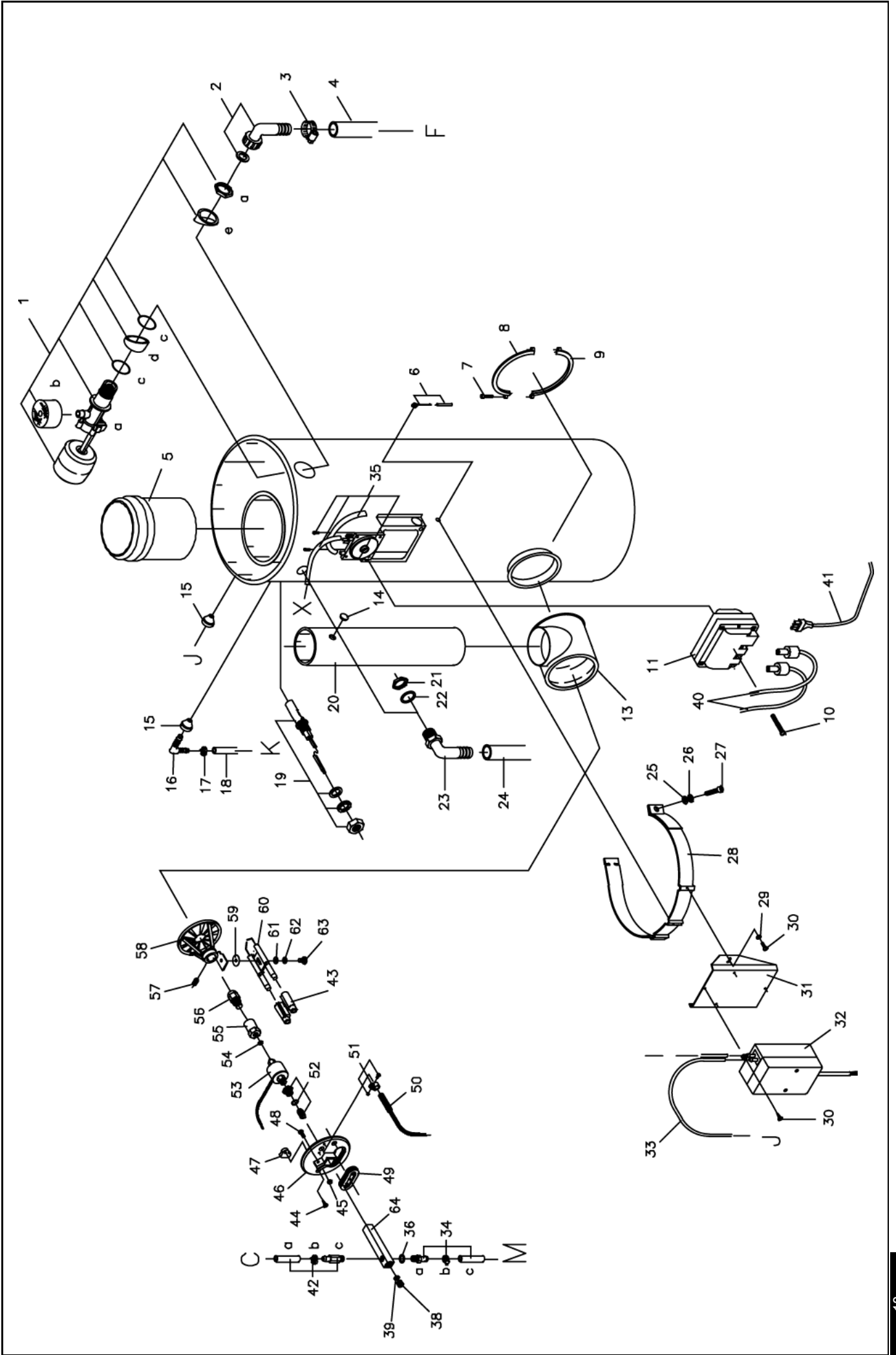

Oliefyr/kedel / Oilburner/boiler / Ölbrenner/Kessel / Brulerur/chaudière

Pos.	Ref. no.	Betegnelse Description	Bezeichnung Description	4102 A	4502 A	4802 A
0	06300793	TRANSFER FOR DOSERPUMPE TRANSFER FOR DOSING PUMP	KLEBSTREIFEN F. DOSIERPUMPE AUTO-COLLANT P. POMPE DEDDOSAGE	1	1	1
01	06261528	SVØMMERVENTIL KPL. G4000 FLOAT VALVE CPL., G4000	SCHWIMMERTVENTIL KPL. VANNE A FLOTTEUR CPL. G30	1	1	1
01A	06100347	SVØMMER KPL. FLOAT VALVE CPL.	SCHWIMMERTVENTIL EINSCHL. MUTTER + DICHT. VANNE FLOTTEUR G-4000S ECS ECROU+JOINT	1	1	1
01B	06120475	SVAMP FOR SVØMMER SPONGE FOR FLOAT	SCHWAMM F. SCHWIMMER EPOGNE P. FLOTTEUR	1	1	1
01C	06120156	O-RING, 32X2 O-RING, 32X2	O-RING JOINT TORIQUE	2	2	2
01D	06200354	AFSTANDSRING FOR SVØMMER DISTANCE RING FOR FLOATER	DISTANZRING F. SCHWIMMER BAQUE ECARTEMENT POUR TTEUTTEUR	1	1	1
01E	06200355	PAKNING FOR SVØMMER GASKET FOR FLOAT VALVE	DICHTUNG F. SCHWIMMER JOINT POUR FLOTTEUR	1	1	1
02	06030681	VINKELSTUDS, 3/4" ANGLE SOCKET, 3/4"	WINKELSTUTZEN PLASTIK RACCORD EQUERRE PLASTIQUE	1	1	1
03	06110471	SPÆNDEBÅND, 14-32 RETAINING RING, 14-32	SCHLAUCHSCHELLE HS12 FRETTE	1	1	1
04	06110467	TILGANGSSLANG, 3/4" X 520 MM INLET HOSE, 3/4" X 520 MM	EINLASS-SCHLAUCH TUYAU ENTREE 4001	1	1	1
05	06061368	SKORSTENSØR CHIMNEY PIPE	SCHORNSTEIN INNEN G4001 CHEMINEE 4001	1	1	1
06	06211589	THERMOFØLER - OVERKOG, 3/4000 THERMAL PROTECTOR - PRIMING, 3/4000	UEBERKOCHEKONTROLLE THERMOSTAT	1	1	1
07	06070801	UNBRACO SKRUE, M6X35 ALLEN SCREW, M6X35	IMBUSS TETE CYLINDRIQUE	2	2	2
08	06110520	SPÆNDEBESLAG, Ø110 FITTINGS, Ø110	BESCHLAG CERCLE D'ASSEM.BRULEUR GA	1	1	1
09	06110512	SPÆNDEBESLAG, Ø110 FITTINGS, Ø110	BESCHLAG CERCLE D'ASSEM.BRULEUR DR	1	1	1
10	06070809	SKRUE, 4X40 SCREW, 4X40	SCHRAUBE VIS	2	2	2
11	06230366	TÆNDTRANSFORMER, 230/400V IGNITION TRANSFORMER, 230/400V	TRANSFORMATEUR ALLUM.230V	1	1	1
11	06230374	TÆNDTRANSFORMER, 200V IGNITION TRANSFORMER, 200V	TRANSFORMATEUR ALLUMAGE, 200V	1	1	1
11	06261526	TÆNDTRANSFORMER, 230/400/415 IGNITION TRANSFORMER, 230/400/415	ZUENDTRANSFORMER TRANSFORMATEUR ALLUMAGE	1	1	1
11	06261527	TÆNDTRANSFORMER, 110/115V IGNITION TRANSFORMER, 110/115V	ZUENDTRANSFORMER TRANSFORMATEUR D'ALLUMAGE	1		
13	06230314	BRÆNDERHUS BURNER HOUSING	BRENNERGEHAUSE CORPS DE COMBUSTIBLE	1	1	1
15	06120111	PAKDASE, C 5-7 STUFFING BOX, C 5-7	STOPFBUCHSE PRESSE-ETOUPE CAOUTCHOUC	2	2	2

Oliefyr/kedel / Oilburner/boiler / Ölbrüner/Kessel / Brulerur/chaudière

Pos.	Ref. no.	Betegnelse Description	4102 A	4502 A	4802 A
16	06030750	REDUKTIONSVINKEL, 6X8 REDUCTION ANGLE, 6X8	1	1	1
17	06110494	SPÆNDEBÅND, 10-12 RETAINING RING, 10-12	1	1	1
18	06110532	ARMERET PLASTSLANGE , 860 MM ARMOURED PLASTIC HOSE , 860 MM	1	1	1
19	06170136	NIVEAUFØLER, 2 M CABLE LEVEL CONTROL, 2 M CABLE	1	1	1
20	06200334	BLÆSERRØR BLOWER PIPE	1	1	1
20	06200544	BLÆSERRØR, Ø75X1,7X400 BLOWER PIPE, Ø75X1,7X400			1
21	06181129	MØTRIK, 36X8 NUT, 36X8	1	1	1
22	06120051	O-RING, 25.3X2,4 O-RING, 25.3X2,4	1	1	1
23	06030736	VINKELSTUDS PLASTIK, 3/4X3/4 ANGLE SOCKET PLASTIC, 3/4X3/4	1	1	1
24	06110459	ARMERET PLASTSLANGE , 700 MM ARMOURED PLASTIC HOSE , 700 MM	1	1	1
25	06080132	SKIVE, 6X30 WASHER, 6X30	1	1	1
26	06080114	SKIVE, M6 WASHER, M6	1	1	1
27	06070447	UNBRACO SKRUE, M6X40 ALLEN SCREW, M6X40	1	1	1
28	06061223	SPÆNDEBESLAG, 30X662X1,5 FITTINGS, 30X662X1,5	1	1	1
29	06080014	SPÆNDESKIVE, M4 TENSION DISC, M4	2	2	2
30	06070511	TAP TITE P/H, M4X8 TAP TITE P/H, M4X8	4	4	4
31	06061285	BESLAG FOR AFKALKNINGSPUMPE FITTINGS FOR DECALCIFICATION PUMP	1	1	1
32	06170131	DOSERINGSPUMPE, 24V/50 HZ DOSING PUMP, 24V/50 HZ	1	1	1
33	06110354	PLASTSLANGE; Ø3X900 PLASTIC HOSE, Ø3X900	1	1	1
34	06261644	BRÆNDSTOFSLANGE TILGANG, KPL. FUELHOSE INLET, CPL.	1	1	1
34B	06110609	SPÆNDEBÅND, 13 RETAINING RING, 13	1	1	1
35	06261705	KIT FOR OMLØBSRETNING KIT FOR DIRECTION OF ROTATION	1	1	1

Oliefyr/kedel / Oilburner/boiler / Ölbrenner/Kessel / Brulerur/chaudière

Pos.	Ref. no.	Betegnelse Description	Bezeichnung Description	4102 A	4502 A	4802 A
36	06120325	KOBBERPAKNING, 10/13.5 COPPER GASKET, 10/13.5	KUPFERDICHTUNG JOINT	1	1	1
38	06181061	PROP, 1/8"RGX8 PLUG, 1/8"RGX8	PFROPEN F. OELMESSTAB CAPUCHON	1	1	1
39	06120087	O-RING, 5,28X1,78 O-RING, 5,28X1,78	O-RING JOINT TORIQUE	1	1	1
40	06161037	TÆNDKABEL, 700 MM IGNITION CABLE, 700 MM	CABLE D ALLUMAGE 2300/250	2	2	2
41	06161079	TILGANGSKABEL GUMMI, 850 MM INLET CABLE RUBBER, 850 MM	KABEL F. ZUNDETROFO. 850MM CABLE D'ENTREE 850MM	1	1	1
42	06261645	BRÆNDSTOFSLANGE RETUR, KPL. FUEL HOSE RETURN, CPL.	OELSCHLAUCH ZURUECK TUYAU FUEL RETURN CPLT	1	1	1
42B	06110564	SPÆNDEBÅND RETAINING RING	SCHLAUCHSCHELLE ABA9 FRETTE	1	1	1
43	06120557	GUMMIHÆTTE RUBBER CAP	CAPUCHON CAOUT.SERIE 4002	1	1	1
44	06070810	SKRUE, 4,8X19 SCREW, 4,8X19	SCHRAUBE VIS POUR BUTEE G-4500	1	1	1
45	06080056	MØTRIK, M4 NUT, M4	MUTTER, GALV. ECROU	1	1	1
46	06200335	DÆKSEL FOR BRÆNDERHUS, 3000/4000 COVER FOR BURNER HOUSING, 3000/4000	DECKEL F. BRENNERGEHAEUSE COUVERCLE P.CORPS DEBUSTIBUSTIBLE	1	1	1
47	06200360	LÅSEPAL FOR DÆKSEL LOCKING PAWL	SCHLISSSCHALTKLINKE F. DECKEL BUTEE DE CANNE DE BRULEURCLE	2	2	2
48	06070341	SKRUE, 4X16 SCREW, 4X16	SCHRAUBE P/K, GALV. VIS	1	1	1
49	06200357	GUMMIGENNEMFØRING RUBBER GROMMET	GUMMIDURCHFUEHRUNG JOINT	1	1	1
50	06230352	FOTOCELLE PHOTOCELL	PHOTOZELLE CELLULE PHOTOELECTRIQUE	1	1	1
51	06230330	SPÆNDERING RETAINING RING	SCHLAUCHSCHELLE F. PHOTOZELLE ANNEAU DE SERRAGE	1	1	1
52	06261552	DYSEFILTER, KPL. NOZZLE FILTER, CPL.	DUESEFILTER KPL. FILTRE GICLEUR CPL. G-300-4000	1	1	1
53	06261571	MAGNETVENTIL, 24V 50/60 HZ SOLENOID VALVE, 24V 50/60 HZ	MAGNETVENTIL KPL. ELECTROVANNE 24V-50-60HZ	1	1	1
53	06262397	MAGNETVENTIL, KPL., G4002 230V SOLENOID VALVE, CPL., G4002 230V	ELECTROVANNE 230V -G4002	1	1	1
54	06120265	O-RING, 7X1.5 O-RING, 7X1.5	O-RING JOINT	1	1	1
55	06181107	DYSEHOLDER, 19X30 NOZZLE HOLDER, 19X30	DUESEHALTER SUPPORT GICLEUR	1	1	1
56	06230277	OLIEDYSE 1,35 GALL OIL NOZZLE, 1.35 GALL 80GR-H	OELDYESE 1,35 GALL. 80H 4,5 KG GICLEUR D'HUILE 1.35 G-40.	1	1	1

Oliefyr/kedel / Oilburner/boiler / Ölbrüner/Kessel / Brülurur/chaudière

Pos.	Ref. no.	Betegnelse Description	Bezeichnung Description	4102 A	4502 A	4802 A
56	06230291	OLIEDYSE 1,10 GALL OIL NOZZLE, 1,10 GALL 3,6 KG 80GR-H	OELDUESE GICLEUR D'HUILE 1,10 G G1.	1		
57	06070047	UNBRACO PINOLSKRUE, M6X6 ALLEN POINTED SCREW, M6X6	IMBUSSREITSTOCKSCHRAUBE VISQUE	1	1	1
58	06230331	BLANDESKIVE MIXING DISC	LUFMISCHSCHEIBE DISQUE D'EMULSION G-3000/	1	1	1
59	06080212	UNDERLAGSSKIVE, Ø20XØ5X0,5 WASHER, Ø20XØ5X0,5	BOLZENSCHIBE RONDELLE	1	1	1
60	06230336	TÆNDELEKTRODE IGNITION ELECTRODE	ZUENDELEKTRODE ELECTRODE D'ALLUMAGE	1	1	1
61	06080087	SPÆNDESKIVE, M8 TENSION DISC, M8	SCHEIBE, GALV. DISQUE	1	1	1
62	06080162	FJEDERSKIVE, M5 SPRING WASHER, M5	FEDERSCHIBE DISQUE	1	1	1
63	06070491	SKRUE, 5X12 SCREW, 5X12	TAP TITE P/K VIS	1	1	1
64	06181108	DYSERØR, 15X15X95 NOZZLE PIPE, 15X15X95	DUESERØHR TUBE INJECTEUR FUEL	1	1	1

Kedel/spiral / Boiler/heating coil / Kessel/Spirale / Chaudière/serpentin

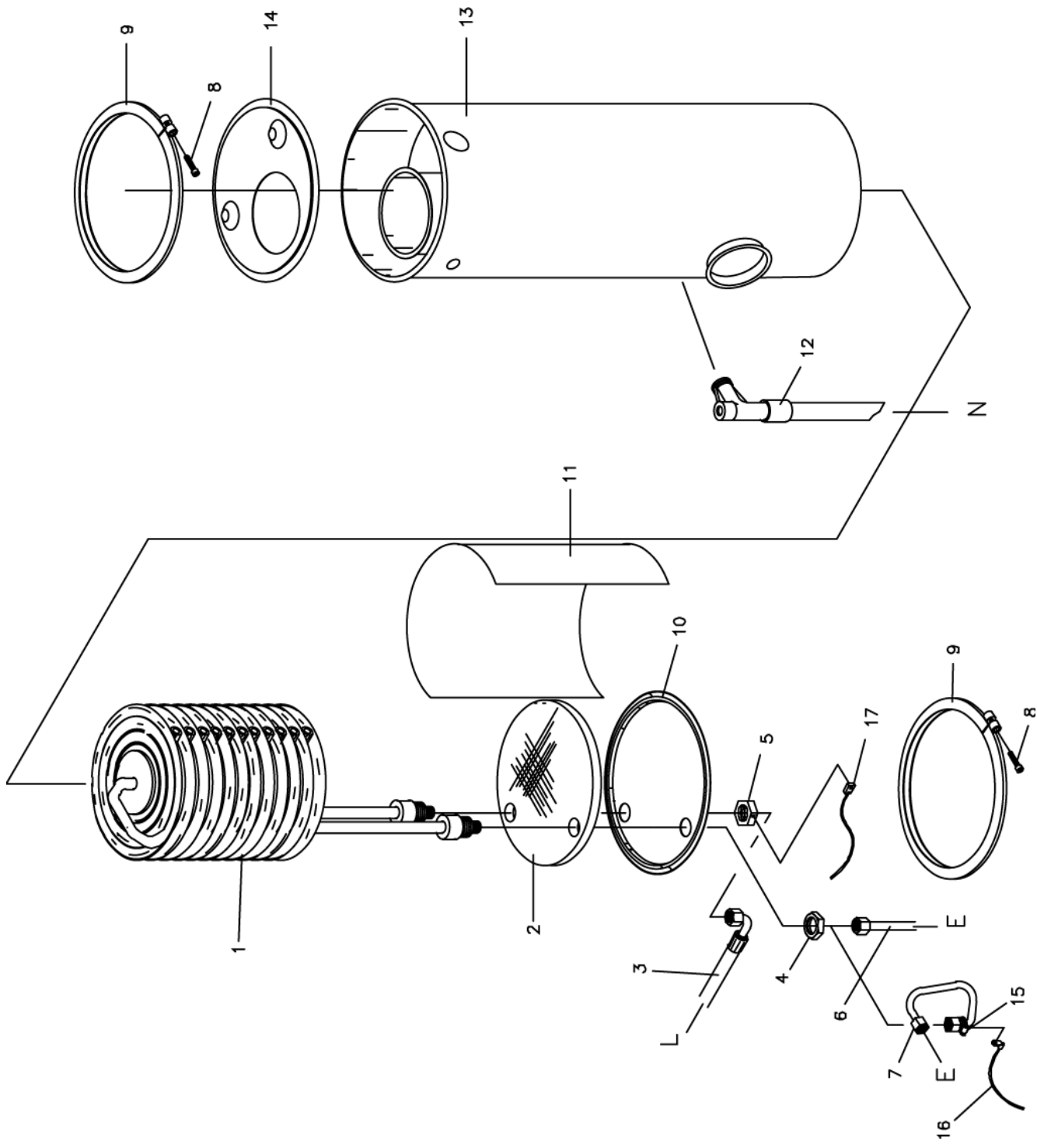

Kedel/spiral / Boiler/heating coil / Kessel/Spirale / Chaudière/serpentin

Pos.	Ref. no.	Betegnelse Description	Bezeichnung Description	4102 A	4502 A	4802 A
01	06211559	SPIRAL, 7-L 41/4500 HEATING COIL, 7-L 41/4500	SPIRALE 7 SCHICHTEN SERPENTIN 11 COUCHES G-41	1	1	
01	06211664	SPIRAL, 9-L 46/4800 HEATING COIL, 9-L 46/4800	SPIRALE 9-SCHICHTEN SERPENTIN 11 COUCHES G-48			1
02	06120423	FIBERRONDEL, Ø252X16 INSULATION, Ø252X16	RUNDTIL ISOLATION CHAUDIERE G-300	1	1	1
03	06110523	SLANGE HOSE	HOCHDRUCKSCHLAUCH TUYAU HP POMPE/CHAUDIÈRE	1	1	1
04	06181129	MØTRIK, 36X8 NUT, 36X8	GEGENMUTTER ECROU G-3000	2	2	2
05	06261530	AFGANGSRØR KOMPLET OUTLET PIPE CPL.	AUSLASSROHR KPL. TUYAU DE DEPART CPL.	1	1	1
06	06070801	UNBRACO SKRUE, M6X35 ALLEN SCREW, M6X35	IMBUSS TÊTE CYLINDRIQUE	2	2	2
07	06110511	SPÆNDEBESLAG, Ø.270 FITTINGS, Ø.270	BESCHLAG CERCLE D'ASSEMBL. CHAUDIER	2	2	2
08	06061212	BUND FOR KEDEL, Ø280X1,0 BOTTOM FOR BOILER, Ø280X1,0	BODEN F. KESSEL FOND DE CHAUDIERE G-4000	1	1	1
09	06061329	VARMEPLADE, 625X445X.5 HEATING PLATE, 625X445X.5	HEIZPLATTE PLAQUE DE CHAUFFAGE G-480	1	1	1
10	06110516	AFGANGSSLANGE KPL. OUTLET HOSE, CPL.	AUSLASSSCHLAUCH KPL. TUYAU	1	1	1
11	06211403	KEDEL KPL., G-4000 BOILER CPL., G-4000	KESSEL KPL. CHAUDIÈRE CPL. G-4000	1	1	1
12	06211547	LAG FOR KEDEL COVER FOR BOILER	DECKEL F. KESSEL COUVERCLE	1	1	1
13	06211403	KEDEL KPL., G-4000 BOILER CPL., G-4000	KESSEL KPL. CHAUDIÈRE CPL. G-4000	1	1	1
14	06211547	LAG FOR KEDEL COVER FOR BOILER	DECKEL F. KESSEL COUVERCLE	1	1	1
15	06110494	SPÆNDEBAND, 10-12 RETAINING RING, 10-12	SCHLAUCHSCHELLE FRETTÉ	1	1	1
16	06170267	TEMPERATURFØLER G2002, G2002 THERMAL PROTECTOR, G2002	DETECTEUR DE TEMPERATURE	1	1	1
17	06262391	OVERKOGSSIKRING, G4002 PRIMING THERMOSTAT, G4002	SONDE D/SURCHAUFFE G4002	1	1	1

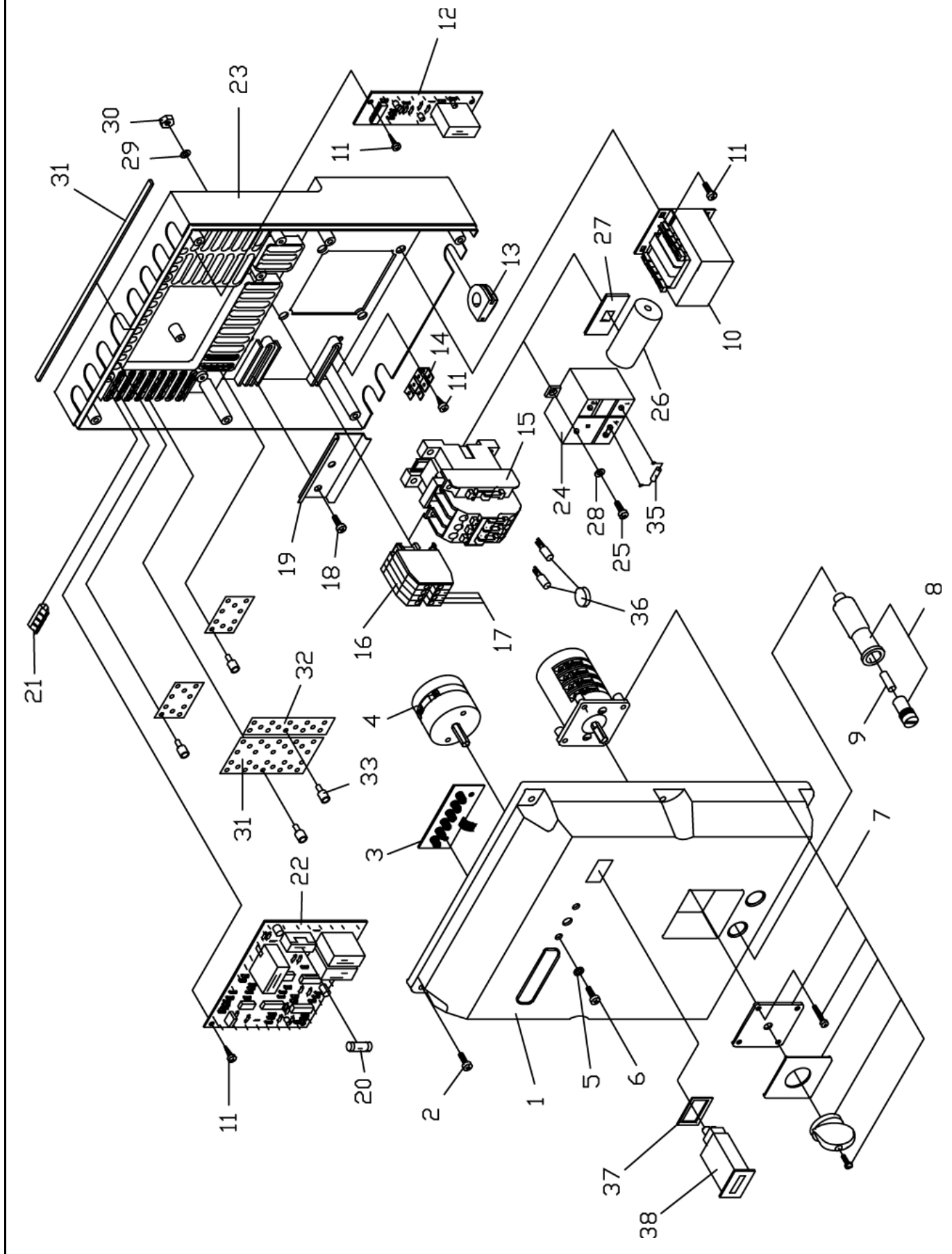

EI-komponenter (4001A/4002A Date < 11.01.2002) / Electric components (4001A/4002A Date < 11.01.2002) / Elektrische komponente (4001A/4002A

Pos.	Ref. no.	Betegnelse Description	Bezeichnung Description	4102 A	4502 A	4802 A
0	06301514	TRANSFERS BETJENING TRANSFERS MANUAL	KLEBSTREIFEN AUTOCOLLANT MODE D'EMPLOI 4000	1	1	1
01	06200322	ELKASLÅG PLAST COVER FOR ELECTRIC BOX	DECKEL F. ELEKTROKASTEN - PLASTIK COUVERCLE PLASTIQUE	1	1	1
02	06070828	SKÆRESKRUE, SORTZINK, 4X12 SCREW, BLACK ZINC, 4X12	PLASTIKTITE VIS 4X12MM = 070505	6	6	6
03	06170214	LYSDIODEPRINT, G4000 LIGHT-EMITTING DIODE PRINT, G4000	LICHTDIODEPRINT UNITE DE CONTROLE	1	1	1
04	06160924	OMSKIFTER M/INDSATS REVERSE WITH INSERT	UMSCHALTER MIT EINSATZ INVERSEUR AVEC INTERIEUR	1	1	1
05	06080110	UNDERLAGSSKIVE, GALV., 1/8" WASHER, GALV., 1/8"	UNTERLAGSSKIBE, GALV. RONDELLE GALVANISEE	2	2	2
06	06070355	SELVSKÆRENDE SKRUE, 3,5X9,5 SELF-TAPPING SCREW, 3,5X9,5	SELBSTSCHR. SCHRAUBE VIS CONIQUE	2	2	2
10	06160938	TRANSFORMER, 400V/24V TRANSFORMER, 400V/24V	STEUERTRANSFORMER OHNE SICHERUNG TRANS. CONTR. SANS FUS.	1	1	1
10	06160940	TRANSFORMER, 110V/24V TRANSFORMER, 110V/24V	TRANSFORMATEUR, 110V/24V	1		
10	06160941	TRANSFORMER, 415V/24V TRANSFORMER, 415V/24V	STEUERTRANSFORMATOR TRANSFORMATEUR COMMANDE	1	1	1
10	06160957	TRANSFORMER, 440V, 50/60HZ TRANSFORMER, 440V, 50/60HZ	TRAF0 EI/60/31/35 TRANSFORMATEUR	1	1	1
11	06070803	SKRUE, 3,5X8 SCREW, 3,5X8	SCHRAUBE VIS	10	10	10
12	06170199	PRINT FLAMMEKONTROL, 4 PRINT FLAME CONTROL, 4	PRINT FLAMMKONTROLLE UNITE DE CONTROLE P.FLAMMME	1	1	1
13	06120320	KABELGENNEMFØRING, Ø25X11 CABLE GROMMET, Ø25X11	KABELDURCHFUEHRUNG F. ELEKTRO-SCHALTK. TRAVERSEE DE CABLETE ELECTE ELECTRIQUE	10	10	10
14	06160822	FLADSTIKFORDELER, 6,3 MM G6000 FLAT PLUG DISTRIBUTOR, 6,3 MM G6000	FLACHSTECHERVERTEILER DISTRIBUTEUR DE PRISE DE COURANT	1	1	1
15	06160062	KONTAKTOR, CI 9 24V/50HZ CONTACTOR, CI 9 24V/50HZ	SCHUETZ CI9 24 V 50/60 HZ CONTACTEUR DANFOSS	1	1	1
15	06160463	KONTAKTOR, 25A 24V/50-60HZ CONTACTOR, 25A 24V/50-60HZ	SCHUETZ CI25 24 V 50/60 HZ CONTACTEUR CI25 24V 50HZ	1	1	1
15	06160464	KONTAKTOR CI15 24 V CONTACTOR, 16A 24V/50-60 HZ	SCHUETZ CI16 24 V 50/60 HZ CONTACTEUR CI15 3X400V	1	1	1
15	06160507	KONTAKTOR, 12A 24V/50-60HZ CONTACTOR, 12A 24V/50-60HZ	SCHUETZ CI12 24 V 50/60 HZ CONTACTEUR CI 12-24V			1
18	06070837	SKRUE, 4,8X9,5 SCREW, 4,8X9,5	PLASTTITE 60Z VIS G-400/880/4000A	2	2	2
19	06160905	SKINNE, 7,5X80 MM PLATE, 7,5X80 MM	GELEISE DIN CERCLE	1	1	1
20	06160067	FINSIKRING, 2 AMP. FUSE, 2 AMP.	SICHERUNG 2 AMP. 4792120207 FUSIBLE	1	1	1

EI-komponenter (4001A/4002A Date < 11.01.2002) / Electric components (4001A/4002A Date < 11.01.2002) / Elektrische komponente (4001A/4002A

Pos.	Ref. no.	Betegnelse Description	Bezeichnung Description	4102 A	4502 A	4802 A
21	06160899	TERMINALER TIL EL-KASSE TERMINALS FOR ELECTRIC BOX	KLEMMEN F. ELEKTROKASTEN CONNECTION DE BOITE ELECTRIQUE	32	32	32
22	06170179	STYREPRINT, G-4000 CONTROL PRINT, G-411/4*5/46/4800	STYUERPRINT UNITE DE CONTROLE G-4000	1	1	1
23	06200321	ELKASSEBUND BOTTOM FOR ELECTRIC BOX	BODEN F. ELEKTROKASTEN - PLASTIK FOND DE COFFRET ELECTR.(R- PLASTIQUE)	1	1	1
24	06270296	STARTRELÆ, 1X230V STARTING RELAY, 1X230V	ANLASSRELAIS RELAIS DE DEMARRAGE, 1X230V	1		
24	06270322	STARTRELÆ, 110V STARTING RELAY, 110V	RELAIS DE DEMARRAGE	1		
25	06070518	SKRUE, M3X16 SCREW, M3X16	SCHRAUBEN ROSTFREI VIS INOX	1		
26	06160936	DRIFTSKONDENSATOR WORKING CAPACITOR	KONDENSATOR CONDENSATEUR DE MARCHE	1		
27	06160454	KLÆBEPLADE GLUE PLATE	KLEBEPLATTE PANDUIT ABMS-A PLAQUE COLLANTE PANDUIT ABMS-A	1		
28	06080183	SKIVE, M3 WASHER, M3	SCHEIBE DISQUE INOX	1		
29	06080158	STJERNESKIVE, M3 TOOTH LOCK WASHER, M3	STERNSCHEIBE TYP I M3 RONDELLE A DENTS TYPE I M3	1		
30	06080055	MØTRIK, M3 NUT, M3	MUTTER GALV. ECROU GALVANISE	1		
31	06200394	STYREPLADE, BRED GUIDING PLATE, BROAD	MACHE FÜR TERMINAL BREIT PLAQUE DE GUIDE G-400/880	4	4	4
32	06200399	STYREPLADE, SMAL GUIDING PLATE, NARROW	MASCHE FÜR TERMINAL PLAQUE DE GUIDE G-880/400TE	2	2	2
33	06160926	TERMINALRØR, 0,5 MM2 THERMINAL PIPE, 0,5 MM2	TERMINALROHR CONNECTEUR G-400/880/4000	12	12	12
34	06160967	TERMINALRØR, 1,5 MM2 THERMINAL PIPE, 1,5 MM2	TERMINALROHR ROT 1MM2 CONNECTEUR G-400/880/4000	24	24	24
35	06211553	MODSTAND RESISTANCE	RÉSISTANCE	1		
37	06120566	PAKNING GASKET	JOINT	1	1	1
37-38	06262330	TIMETÆLLER KIT, 4001A HOUR METRE KIT, 4001A	COMPTER HORAIRE KIT, 4001A	1	1	1
38	06220054	TIMETÆLLER, 24V HOUR METRE, 24V	COMPTEUR HORAIRE 24V	1	1	1

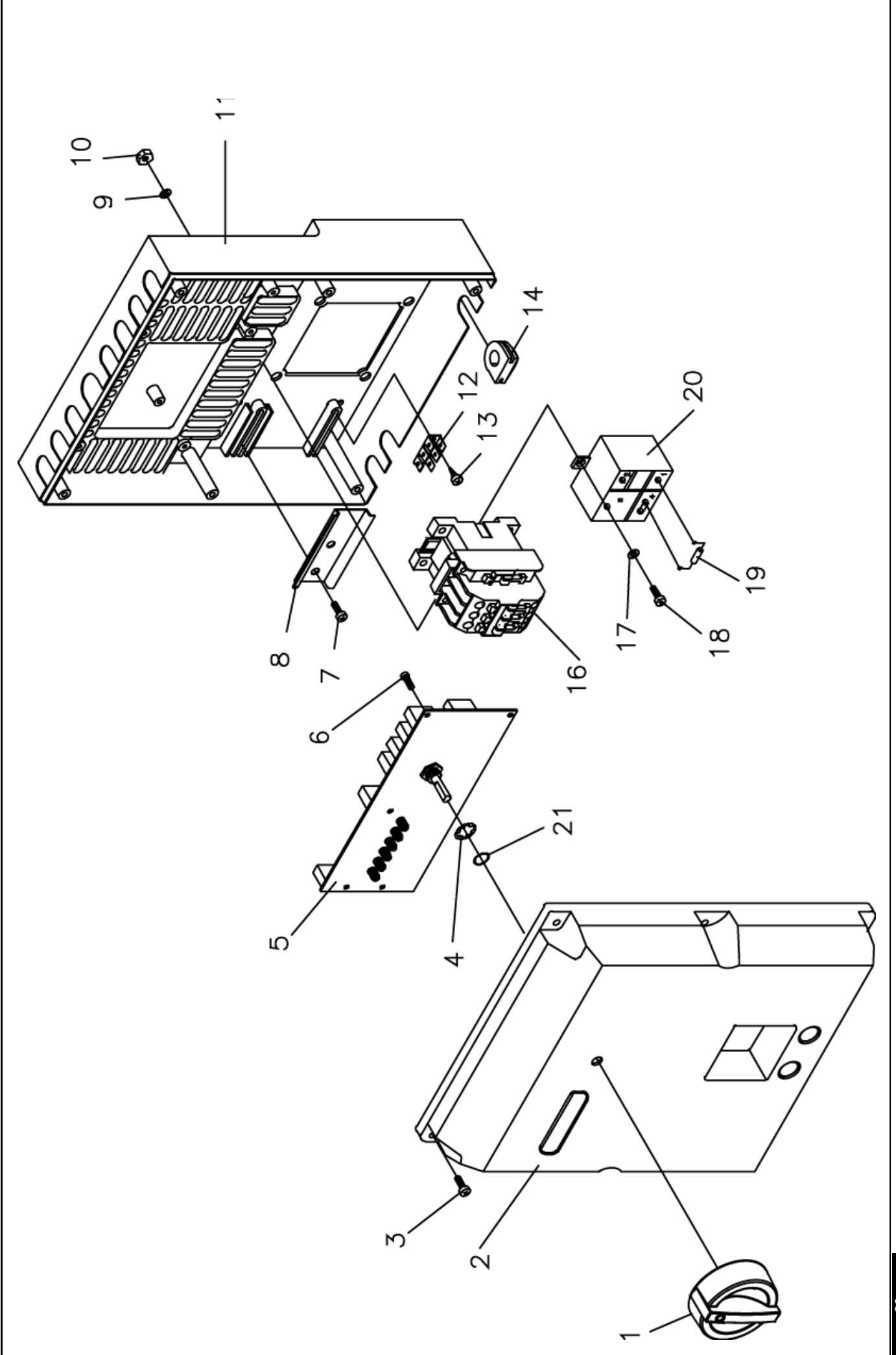

EI-komponenter (4002A Date > 11.01.2002) / Electric components (4002A Date > 11.01.2002) / Elektrische komponente (4002A Date > 11.01.2002)

4102 A 4502 A 4802 A

Pos.	Ref. no.	Betegnelse Description	Bezeichnung Description	1	1	1
01	06200552	START/STOP KONTAKT, 4002 START/STOP SWITCH, 4002	BOULTON MISE EN MISE	1	1	1
02	06200551		COFFRET ELECTRIQUE	1	1	1
03	06070828	SKÆRESKRUE, SORTZINK, 4X12 SCREW, BLACK ZINC, 4X12	PLASTIKTITE VIS 4X12MM = 070505	6	6	6
04	06080275			1	1	1
05	06170274	PRINT, G4002 400-415V PRINT, G4002 400-415V	UNITE DE CONTROLE, G4002 3X400	1	1	1
05	06170275	PRINT, G4002 200-230V PRINT, G4002 200-230V	CARTE ELECTRONIQUE 230V	1	1	1
07	06070837	SKRUE, 4,8X9,5 SCREW, 4,8X9,5	PLASTITE 60Z VIS G-400/880/4000A	2	2	2
08	06160905	SKINNE, 7,5X80 MM PLATE, 7,5X80 MM	GELEISE DIN CERCLE	1	1	1
09	06080158	STJERNESKIVE, M3 TOOTH LOCK WASHER, M3	STJERNESKIBE TYP I M3 RONDELLE A DENTS TYPE I M3	1		
10	06080055	MØTRIK, M3 NUT, M3	MUTTER GALV. ECROU GALVANISE	1		
11	06200550	ELKASSE, 4002 ELECTRIC BOX, 4002	BOITE ELECTRIQUE, 4002	1	1	1
12	06160822	FLADSTIKFORDELER, 6,3 MM G6000 FLAT PLUG DISTRIBUTOR, 6,3 MM G6000	FLACHSTECHERVERTEILER DISTRIBUTEUR DE PRISE DE COURANT	1	1	1
13	06070803	SKRUE, 3,5X8 SCREW, 3,5X8	SCHRAUBE VIS	12	12	12
14	06120320	KABELGJENNEMFØRING, Ø25X11 CABLE GROMMET, Ø25X11	KABELDURCHFUEHRUNG F. ELEKTRO-SCHALTK. TRAVERSEE DE CABLETE ELECTE ELECTRIQUE	10	10	10
16	06160062	KONTAKTOR, CI 9 24V/50HZ CONTACTOR, CI 9 24V/50HZ	SCHUETZ CI9 24 V 50/60 HZ CONTACTEUR DANFOSS		1	1
16	06160463	KONTAKTOR, 25A 24V/50-60HZ CONTACTOR, 25A 24V/50-60HZ	SCHUETZ CI25 24 V 50/60 HZ CONTACTEUR CI25 24V 50HZ	1		1
16	06160464	KONTAKTOR CI15 24 V CONTACTOR, 16A 24V/50-60 HZ	SCHUETZ CI16 24 V 50/60 HZ CONTACTEUR CI15 3X400V	1		1
16	06160507	KONTAKTOR, 12A 24V/50-60HZ CONTACTOR, 12A 24V/50-60HZ	SCHUETZ CI12 24 V 50/60 HZ CONTACTEUR CI 12-24V			1
17	06080183	SKIVE, M3 WASHER, M3	SCHEIBE DISQUE INOX	1		
18	06070518	SKRUE, M3X16 SCREW, M3X16	SCHRAUBEN ROSTFREI VIS INOX	1		
19	06211553	MODSTAND RESISTANCE	RÉSISTANCE	1		
20	06270296	STARTRELÆ, 1X230V STARTING RELAY, 1X230V	ANLASSRELAIS RELAIS DE DEMARRAGE, 1X230V	1		

EI-komponenter (4002A Date > 11.01.2002) / Electric components (4002A Date > 11.01.2002) / Elektrische komponente (4002A Date > 11.01.2002)

4102 A 4502 A 4802 A

Pos.	Ref. no.	Betegnelse Description	Bezeichnung Description
20	06270322	STARTRELÆ, 110V STARTING RELAY, 110V	1
21	06120024	O-RING, 9,25X1,78 O-RING, 9,25X1,78	1 1 1
		RELAI DE DEMARRAGE	
		O-RING JOINT TORIQUE MAT 4470	

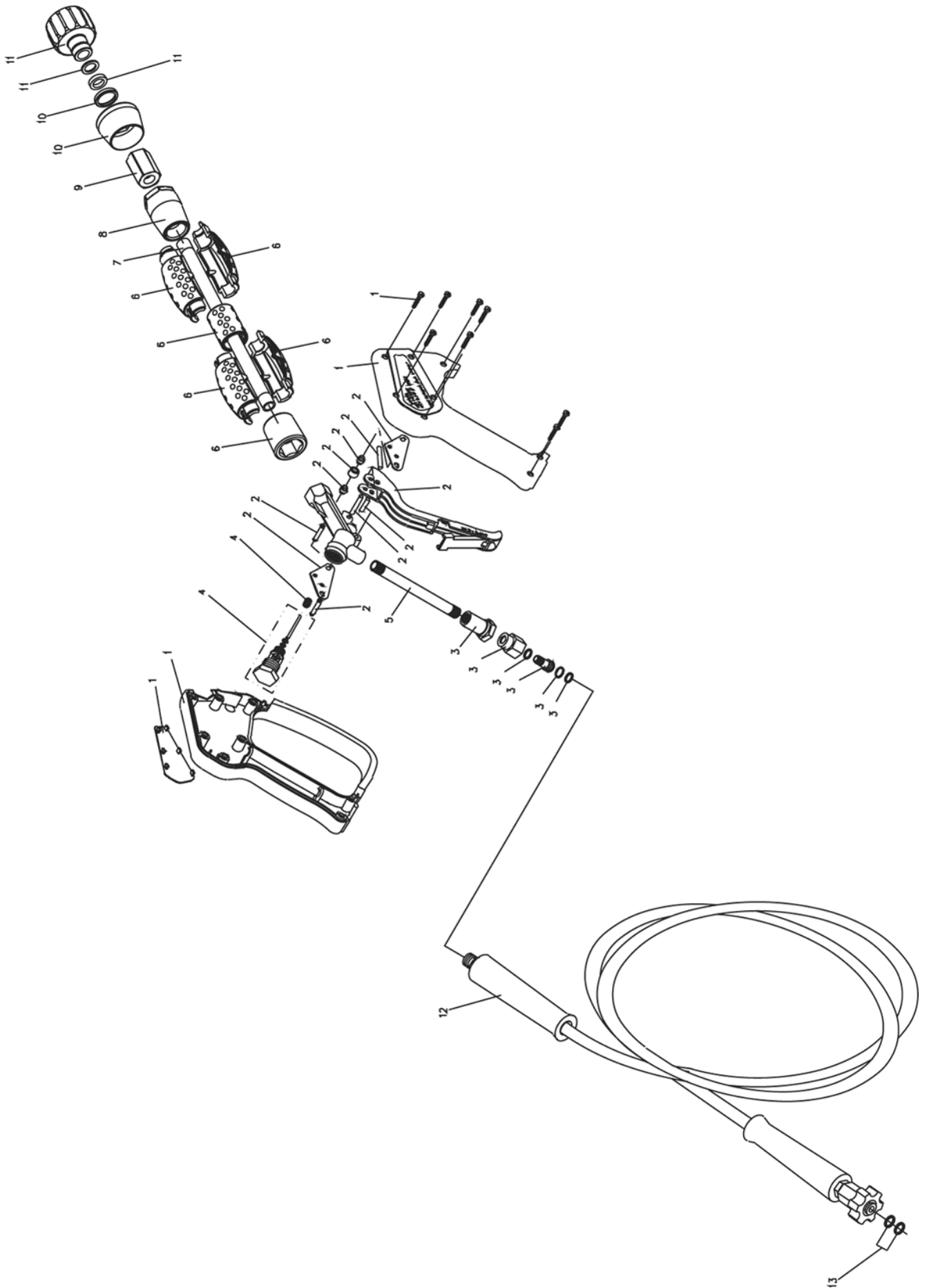

Pistol / Pistol / Pistole / Pistolet

Pos.	Ref. no.	Betegnelse Description	Bezeichnung Description	4102 A	4502 A	4802 A
0	06290111	PISTOL - EGT 2600 - LANG MED SWIVEL, LYNKOBLING PISTOL - EGT 2600 - LONG W. SWIVEL, QUICK COUP.	PISTOLET EGT2600 RAC.RAPI	1	1	1
0	06290121	O-RINGSKIT FOR PISTOL O-RING KIT FOR PISTOL	JOINT A LEVRE .P/290111	1	1	1
01	06290119	PISTOLKROP KPL. PISTOL HOUSING CPL.	CORPS PISTOLET 290111	1	1	1
02	06290120	AFTRÆKKER KIT PULLER KIT	KIT DETENTE P/PIST.290111	1	1	1
03	06290122	DREJELED, KPL. SWIVEL, CPL.	JOINT TOURN.P/PIST.290111	1	1	1
04	06290123	VENTIL KPL. VALVE CPL.	VANNE P/PISTOLET 290111	1	1	1
05	06290124	TILGANGSRØR INLET PIPE	TUYAU D'ENTREE P/290111	1	1	1
06	06290125	KAPPEKIT CAP KIT	PROTECTION P/290111	1	1	1
07	06290126	FORRØR FOR PISTOL FRONT PIPE FOR PISTOL	TUBE AVANT P/PISTOL.290111	1	1	1
08	06290127	AFSTANDSSTYKKE DISTANCE PIECE	ENTRETOISE P/PISTOL290111	1	1	1
09	06290128	MUFFE SOCKET	MANCHON P/PISTOL 290111	1	1	1
10	06290129	AFSTANDSSTYKKE DISTANCE PIECE	ENTRETOISE P/PISTOL290111	1	1	1
11	06290130	LYNKOBLING KPL. QUICK COUPLING CPL.	RACCORD RAPID.PIST.290111	1	1	1
12	06110475	HØJTRYKSSLANGE DN8X10M HIGH PRESSURE HOSE, 3/8"X3/8" NIPPLE, Ø8 MM 10 M	HØCHDRUCKSCHLAUCH M. SCHRAUBENKUPPLUNGEN TUYAU H.P.SCHIF-AV.RAC.AEER A/RAC. A VIS	1	1	1
13	06260936	PAKNINGSKIT F. SKRUEKOB. GASKET KIT FOR SCREW COUPLING	DICHTUNGSKIT F. SCHRAUBENKUPPLUNG KIT JOINT RACCORD VIS VIS	1	1	1

Spulerør / Lances / Lanzen / Lance

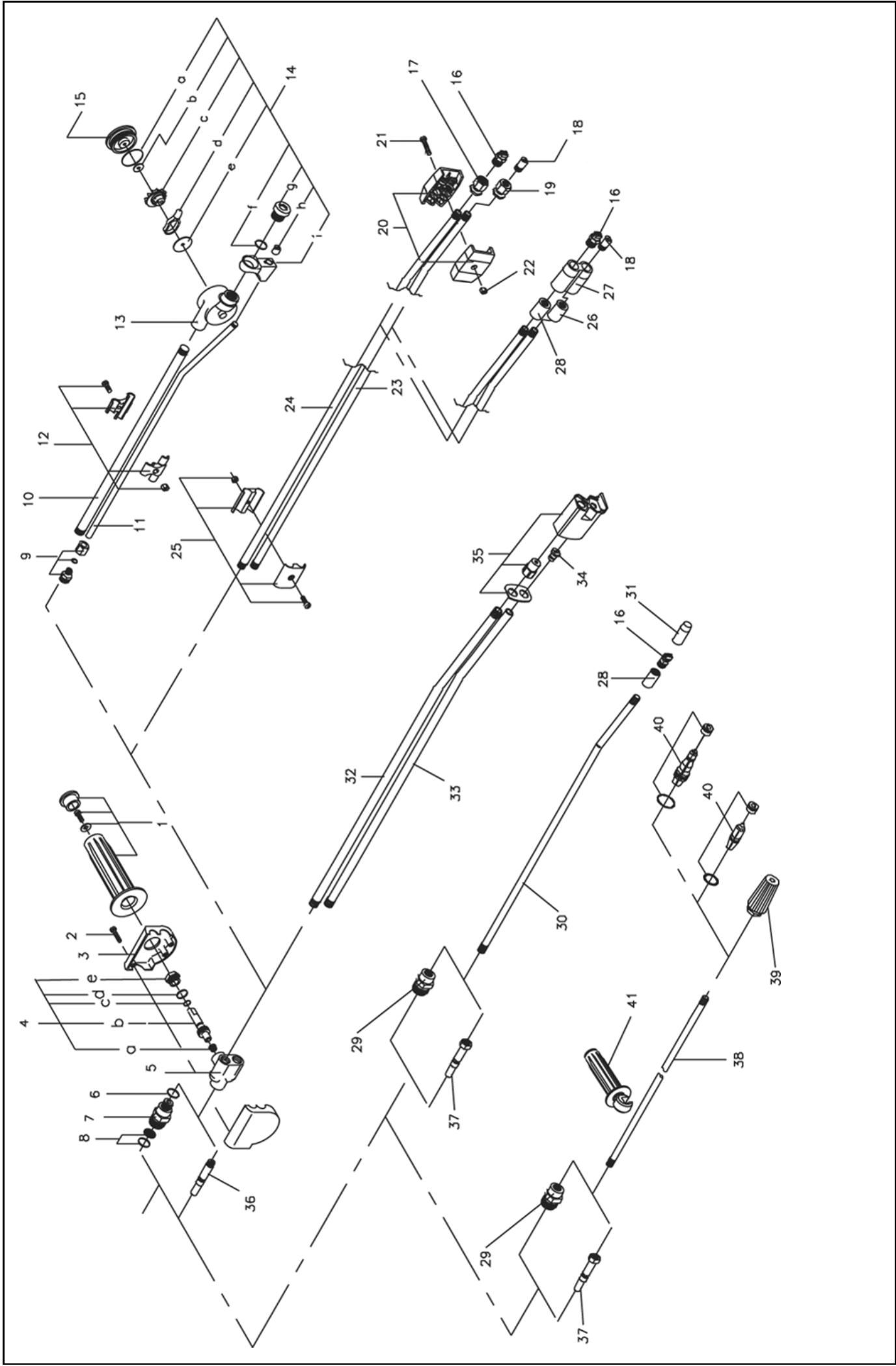

Spulerør / Lances / Lanzen / Lance

Pos.	Ref. no.	Betegnelse Description	Bezeichnung Description	4102 A	4502 A	4802 A
01	06260232	HANDTAGSKIT F. SPULERØR HANDLE KIT	HANDGRIFFKIT F. DOPPELLANZE KIT SERVICE AVEC POIGNEENNE DOUBLE	1	1	1
02	06070479	SKRUE, 4X20 SCREW, 4X20	SCHNEIDSCHRAUBE, SCHWARZZINK VIS	3	3	3
03	06200097	PYNTEDÆKSEL F. VENTILHUS COVER F. VALVE HOUSING	STAUWKAPPE F. VENTILGEHAE COUVERCLEOR. D. VAN OR. D. VAN	1	1	1
04	06260860	VENTILSPINDEL KIT VALVE SPINDLE KIT	VENTILSPINDELKIT F. DRUCKREGELUNG KIT REGLAGE PRESSION DOUBLE. PRES.	1	1	1
04C	06120006	O-RING, 6,75X1,78 O-RING, 6,75X1,78	O-RING JOINT TORIQUE MAT 4470	1	1	1
04D	06120010	O-RING, 13,1X1,6 O-RING, 13,1X1,6	O-RING JOINT TORIQUE MAT 4470	1	1	1
04E	06190245	MØTRIK NUT	MUTTER F. VENTIL ECROU POUR VANNE DOUB.LAN	1	1	1
05	06211078	VENTILHUS VALVE HOUSING	VENTILGEHAEUSE, KPL. CULASSE LANCE DOUBLE ET	1	1	1
06	06120188	O-RING, 10X2 O-RING, 10X2	O-RING JOINT TORIQUE	1	1	1
07	06030484	SKRUEKOBLING 1/4 UD.V. SCREW COUPLING ROTATABLE, 1/4"	SCHR.KUPPLUNG DREHBAR F.DOPPELLANZE ACCOUPL. VIS TOURNANT DBL LANCE DOUBLE	1	1	1
08	06100332	FILTER FOR TURBO LASER FILTER FOR TURBO LASER	FILTER F. TURBO LASER M. O-RING FILTRE TURBO LASER	1	1	1
08A	06120139	O-RING, 10X1 O-RING, 10X1	O-RING JOINT SPY JET	1	1	1
09	06030527	BRYSTNIPPEL, 8X1/4" BREAST NIPPLE, 8X1/4"	GEWINDESTUECK RACCORD	1	1	1
0A	06261373	TURBO-LASER 600 MM TURBO LASER W. PRES. REG. - SCREW - 600 MM, 4.0	TURBO LASER 600 MM TURBO LASER 600MM	1		
0A	06261461	TURBO LASER M/ TRYKREG. - SKRUE - 600 MM, 4.5+ TURBO LASER W. PRES. REG. - SCREW - 600 MM, 4.5+	TURBO LASER 600 MM TURBO LASER 600MM G-310/4	1		
0A	06261889	TURBO LASER M/ TRYKREG. - SKRUE - 600 MM, 4.5 TURBO LASER W. PRES. REG. - SCREW - 600 MM, 4.5	TURBO LASER TURBO LASER 600MM 481A		1	
0A	06262075	TURBO LASER M/ TRYKREG. - LYN - 600 MM, 4.0 TURBO LASER W. PRES. REG. - SCREW - 600 MM, 4.0	TURBO-LASER 600MM RAPIDE		1	
0A	06262077	TURBO-LASER 600MM QUICK TURBO LASER W. PRES. REG. - QUICK - 600 MM, 4.5+	TURBO-LASER 600MM RAPIDE	1		
0A	06262086	TURBO LASER M/ TRYKREG. - LYN - 600 MM, 4.5 TURBO LASER W. PRES. REG. - QUICK - 600 MM, 4.5	TURBO-LASER 600MM RAPIDE		1	
0B	06260758	DOBBLT SPULERØR 600MM EXCL.TRYKDYSE DOUBLE LANCE - PRES. REG.- SCREW -600 MM,	DOPPELLANZE DOUBLE LANCE 600MM	1	1	1
0B	06262063	DOBBL SPULERØR 600MM QUICK DOUBLE LANCE - PRES. REG.- QUICK -600 MM,	LANCE DOUBLE RAPIDE, 600M	1	1	1
0C	06260382	ENKELT SPULERØR 600 MM SINGLE LANCE - SCREW - 600 MM, EXCL.NOZ	EINZELLANZE LANCE SIMPLE 600 MM	1	1	1

Spulerør / Lances / Lanzen / Lance

Pos.	Ref. no.	Betegnelse Description	Bezeichnung Description	4102 A	4502 A	4802 A
0C	06262059	ENK.SPULERØR 600MM QUICK SINGLE LANCE - QUICK - 600 MM, EXCL.NOZ	LANCE SIMPLE RAPIDE, 600M	1	1	1
0D	06261957	SPECTRUM 600MM U/TRYKDYSE SPECTRUM W. PRES. REG. - SCREW - 600 MM,	SPECTRUM OHNE DÜSE - 600 MM SPECTRUM SANS GICLEUR - 600 MM	1	1	1
0D	06261988	SPECTRUM M/ TRYKREG. - SKRUE - 600 MM, 140+ SPECTRUM W. PRES. REG. - SCREW - 650 MM, 140+	SPECTRUM DÜSE LANCE SPECTRUM POUR	1	1	1
0D	06261989	SPECTRUM M/ TRYKREG. - SKRUE - 600 MM, 145 SPECTRUM W. PRES. REG. - SCREW - 650 MM, 145	SPECTRUM DÜSE LANCE SPECTRUM	1	1	1
0D	06262091	SPECTRUM M/ TRYKREG. - LYN - 600 MM, 140 SPECTRUM W. PRES. REG. - QUICK - 600 MM, 140	SPECTRUM - REG. DE PRES. - RAC. RAP. - 600 MM-140	1	1	1
0D	06262092	SPECTRUM M/ TRYKREG. - LYN - 600 MM, 145 SPECTRUM W. PRES. REG. - QUICK - 600 MM, 145	LANCE SPECTRUM 600/44.5MM	1	1	1
0D	06262253	SPECTRUM 600 U.DYSE QUICK SPECTRUM W. PRES. REG. - QUICK - 600 MM,	LANCE SPECTRUM R.R-S/GICL	1	1	1
0E	06262111	ROTO JET LANCE 040 600MM ROTO JET - SCREW - 600 MM, 4.0	LANCE ROTO JET 040	1	1	1
0E	06262112	ROTO JET LANCE 045 600MM ROTO JET - SCREW - 600 MM, 4.5	LANCE ROTO JET 045	1	1	1
0E	06262122	ROTO JET M/ LYN - 600 MM, 4.0 ROTO JET - QUICK - 600 MM, 4.0	LANCE ROTO JET RAPIDE 040	1	1	1
0E	06262123	ROTO JET M/ LYN - 600 MM, 4.5 ROTO JET - QUICK - 600 MM, 4.5	LANCE ROTO JET RAPIDE 045	1	1	1
10	06050841	SPULERØR LIGE, Ø13X1,5X586 LANCE STRAIGHT, Ø13X1,5X586	LANZE GERADE TURBO LASER LANCE DROITE TURBO LASER	1	1	1
11	06050842	KEMIRØR 15 GR. BUK , Ø8X1X622 DETERGENT PIPE 15 DEG., Ø8X1X622	REI.MITTLEROHR 15 GR. VERB. F. T. L. TUYAU POUR LANCESEUR, 15 DSER, 15 DEGRES	1	1	1
12	06261130	BESLAG FOR TURBO LASER FITTINGS FOR TURBO LASER	BESCHLAG F. TURBO LASER ROHR ARMATURE POUR TURBO LASER TUYAU	1	1	1
13	06261289	TURBO LASER HUS , Ø2,7 MAX 720 L TURBO LASER HOUSING, Ø2,7 MAX 720 L	GEHÄUSE F. TURBO-LASER CORPS DE TURBO LASER CPL. CPL.	1	1	1
13	06261917	TURBO LASER HUS , Ø3,4 TURBO LASER HOUSING, Ø3,4	GEHÄUSE F. TURBO LASER CORPS DE TURBO LASER	1	1	1
14	06261371	TURBO LASER KIT, 4.0 TURBO LASER KIT, 4.0	SERVICE KIT F. TURBO LASER KIT SERV.T.L. G-350/3000/ LASER	1	1	1
14	06261459	TURBO LASER KIT, 4.5+ TURBO LASER KIT, 4.5+	SERVICEKIT F. TURBO LASER KIT POUR TURBO LASER LASE LASER	1	1	1
14	06261890	TURBO LASER KIT, 4.5 TURBO LASER KIT, 4.5	SERVICEKIT F. TURBO LASER KIT SERVICE TURBO LASER	1	1	1
14A	06120544	O-RING, 36.0X1,78 O-RING, 36.0X1,78	JOINT TORIQUE	1	1	1
14F	06120282	O-RING, 14X1,78 O-RING, 14X1,78	O-RING JOINT TORIQUE 14 X 1,78	1	1	1
14H	06180533	DYSE, Ø10X12 NOZZLE, Ø10X12	DUESE GICLEUR DIA. 10X12	1	1	1

Spulerør / Lances / Lanzen / Lance

Pos.	Ref. no.	Betegnelse Description	4102 A	4502 A	4802 A
15	06180936	LAG FOR TURBO LASER COVER FOR TURBO LASER	1	1	1
16	06090202	DYSE HÆRDET 1/4-1504,5 FLAT JET NOZZLE 15°, 4,5	1	1	1
16	06090233	DYSE HÆRDET 1/4-1504 FLAT JET NOZZLE 15°, 4	1	1	1
17	06180780	DYSEHOLDER, 17X20 NOZZLE HOLDER, 17X20	1	1	1
18	06180779	KEMIDYSE, Ø10X22 DETERGENT NOZZLE, Ø10X22	1	1	1
19	06180781	DYSEHOLDER FOR KEMI, 17X20 NOZZLE HOLDER FOR DETERGENTS, 17X20	1	1	1
20	06200226	DYSEBESKYTTER NOZZLE PROTECTION, PLASTIC	2	2	2
21	06070497	SKRUE, 5X22 SCREW, 5X22	1	1	1
22	06080123	MØTRIK, M5 NUT, M5	1	1	1
23	06050941	KEMI-RØR, RUSTFRI, Ø13X1,5X591 DETERGENT PIPE, STAINLESS, Ø13X1,5X591	1	1	1
24	06050940	SPULERØR, RUSTFRI, Ø13X1,5X596 LANZE, STAINLESS, Ø13X1,5X596	1	1	1
25	06260537	BESLAG F. DOBB. SPULERØR FITTINGS FOR DOUBLE LANCE	1	1	1
26	06181232	DYSEHOLDER FOR KEMI, Ø18X26 NOZZLE HOLDER FOR DETERGENTS, Ø18X26	1	1	1
27	06200374	DYSEBESKYTTER DOBBELT NOZZLE PROTECTION, PLASTIC, DOBBLE	1	1	1
28	06030643	MUFFE FOR SPULERØR, Ø10 SOCKET FOR LANCE, Ø10	1	1	1
28	06181233	DYSEHOLDER, Ø18X26 NOZZLE HOLDER, Ø18X26	1	1	1
29	06030485	SKRUEKOBLING, 1/4" INDV. SCREW COUPLING, 1/4"	1	1	1
30	06050116	SPULERØR, RUSTFRI, Ø13X586 LANZE, STAINLESS, Ø13X586	1	1	1
31	06200375	DYSEBESKYTTER ENKELT NOZZLE PROTECTION, PLASTIC, SINGLE	1	1	1
35	06261966	SPECTRUM KIT, 140 SPECTRUM KIT, 140	1	1	1
35	06261967	SPECTRUM KIT, 145 SPECTRUM KIT, 145	1	1	1
36	06030649	LYNKOBLING 1/4 UDV. QUICK COUPLING, 1/4"	1	1	1

Spulerør / Lances / Lanzen / Lance

Pos.	Ref. no.	Betegnelse Description	Bezeichnung Description	4102 A	4502 A	4802 A
37	06030827	NIPPEL QUICK-1/4" INDV. NIPPLE, 1/4"	RACCORD RAPIDE 1/4" INTER	1	1	1
38	06050841	SPULERØR LIGE, Ø13X1,5X586 LANCE STRAIGHT, Ø13X1,5X586	LANZE GERADE TURBO LASER LANCE DROITE TURBO LASER	1	1	1
39	06262133	ROTO JET DYSE KPL., 4.0 ROTO JET NOZZLE CPL., 4.0	GICLEUR ROTO CPL. 4.0	1		
39	06262134	ROTO JET DYSE KPL., 4.5 ROTO JET NOZZLE CPL., 4.5	GICLEUR ROTO CPL. 4.5	1		1
40	06262222	ROTO DYSE KIT, 4.0 ROTO JET NOZZLE KIT, 4.0	KIT POUR GICLEUR ROTO 040		1	
40	06262223	ROTO DYSE KIT, 4.5 ROTO JET NOZZLE KIT, 4.5	KIT POUR GICLEUR ROTO 045	1		1
41	06260365	HANDGØR TIL ROT. BØRSTER OG ENKELT LANSEØR, HANDLE FOR ROTATING BRUSHES AND SINGLE	HANDGØRIF POIGNEE DE MAINTIEN LANCE	1	1	1