

BA 410

Model:
BA 410
BA 410 CN
BA 410S CN



Part List US-English

24-07-2012

Table of Contents

BA 410

Solution tank	3
Vacuum system	5
Recovery tank - before Serial no. 054418642	7
Recovery tank - from Serial no. 054418642	9
Handle assembly	11
Solution system	13
Squeegee assembly	15
Brush system - before Serial no. 054920336	17
Brush system - from Serial no. 054920336	19
Wiring system	21
Accessory: Squeegee curved	23
Accessories: Brush, pad, others	25
Recommended spare parts	27
Wiring diagram - before Serial no. 055121383	30
Wiring diagram - from Serial no. 055121383	32

Solution tank

BA 410

24-07-2012

Part List ID
E79103

3

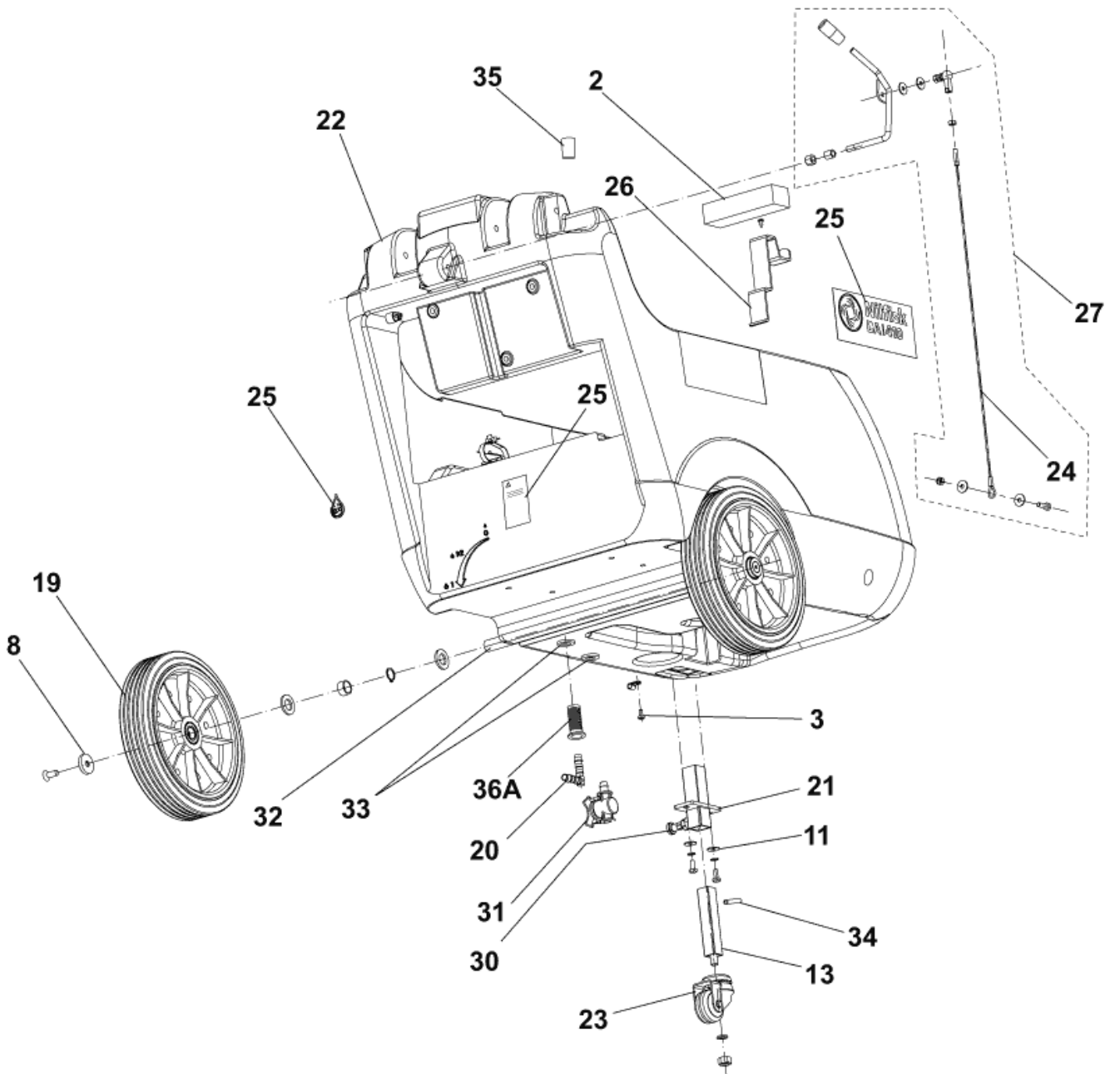
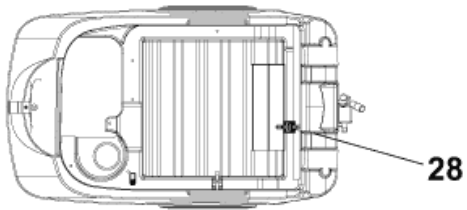

Solution tank

BA 410

24-07-2012

Part List ID
E79103

4

Pos	Part no.	Qty	Description	
0	909 5986 000	1	HARDWARE. TANK FIXING KIT	
0	909 6226 000	1	RUBBER SHOCK ABSORBER KIT	OPTION INST.INSTR.CODE 909 6227 000
2	909 5674 000	1	SPONGE INLET FRESH WATER TANK	
3	L08603041	5	SCREW M5X10 UNI7985 SELFLOCKING	
8	L08812392	2	BUSHING	
11	L08228600	4	WASHER 6X18 UNI6592	
13	909 5658 000	1	ROD MACHINE SUPPORTING	See note
19	9099410000	2	WHEEL D.250X50 GREY-BLACK	TSB IT 2007-015
20	909 5285 000	1	ELBOW 90. D.10 NYLON	
21	909 5649 000	1	SUPPORT	See note
22	909 5551 000	1	TANK SOLUTION	
23	909 5560 000	1	WHEEL	See note
24	909 5573 000	1	CABLE SQUEEGEE LIFTING	
25	9097769000	1	DECALS KIT BA 410	
26	909 5644 000	1	BRACKET	
27	909 5700 000	1	CABLE SQUEEGEE LIFT KIT	
28	145 0524 000	3	CLAMP BLACK 4.8x200	
30	9099135000	1	PLUNGER INDEXING	See note
31	909 5696 000	1	VALVE	
32	909 5748 000	1	SHAFT WHEELS	
33	909 5286 000	2	GASKET	
34	909 6441 000	1	PIN 3X20 UNI6873	See note
35	909 6236 000	1	CAP BLACK	
36A	9096916000	1	FILTER SOLUTION TANK	OPTION

When stock of Pos. 13-21-23-30-34 run out they will be replaced by Item No. 9099705000

Vacuum system

BA 410

24-07-2012

Part List ID
E79105

5

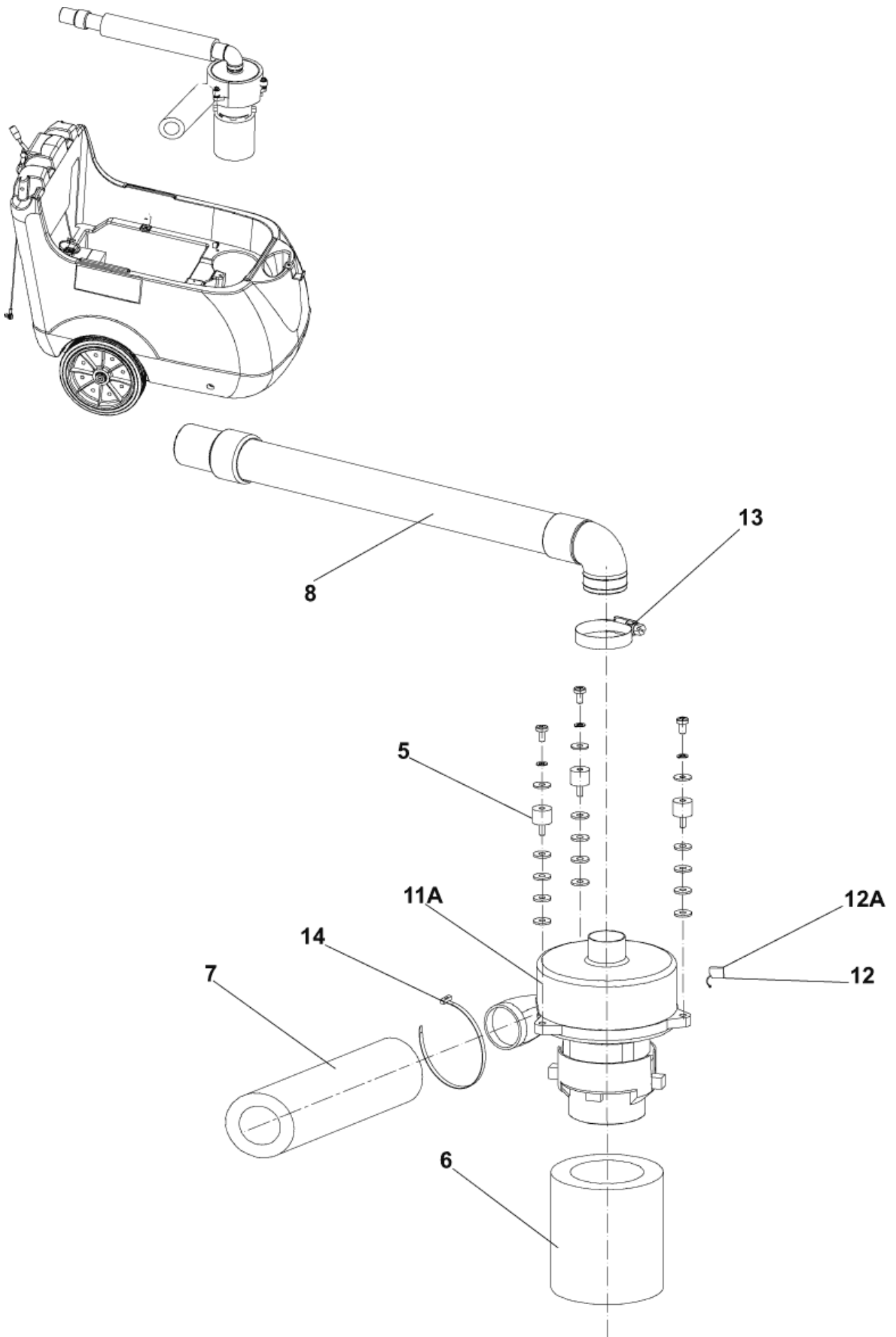

Vacuum system

BA 410

24-07-2012

Part List ID E79105

6

Pos	Part no.	Qty	Description
0	909 5987 000	1	HARDWARE. VAC.MOTOR KIT
5	909 5198 000	3	VIBRATION DAMPING M 6
6	909 5564 000	1	PIPE ACOUSTIC INSULATION
7	909 5565 000	1	PIPE ACOUSTIC INSULATION
8	909 5579 000	1	HOSE VACUUM MOTOR
11	909 5713 000	1	MOTOR VACUUM KIT
12	909 5371 000	2	BRUSH CARBON
12	9098231000	1	CARBON BRUSH KIT 2PCS
13	145 0543 000	1	CLAMP 14/32-52
14	L08812587	1	CLAMP 4.8X430 WHITE

Position 12: 9098231000 valid for motor kit 9098233000

Position 12: 909 5371 000 valid for motor kit 909 5713 000

Recovery tank - before Serial no. 054418642

BA 410

24-07-2012

Part List ID
E79107

7

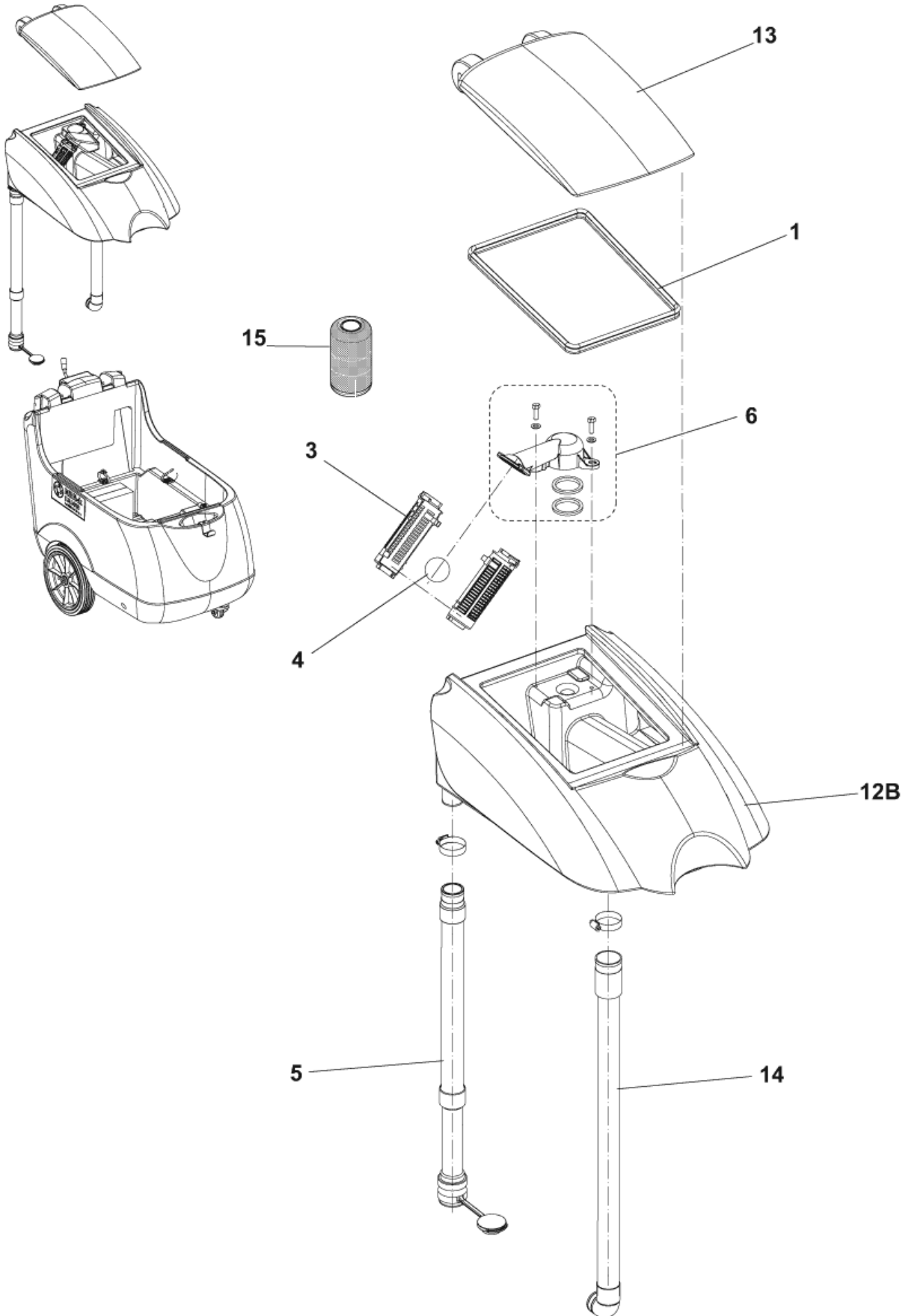

Recovery tank - before Serial no. 054418642

BA 410

24-07-2012

Part List ID

E79107

8

Pos	Part no.	Qty	Description	
0	909 5988 000	1	HARDWARE. TANK FIXING KIT	
1	909 5716 000	1	GASKET	
3	L08812259	2	CAGE.FLOAT CPL	
4	L08812373	1	BALL FLOATING	
5	9099687000	1	HOSE DRAIN	
6	9097681000	1	CAGE FLOAT HOLDER KIT	TSB IT 2008-009 - INSTR.CODE 9097680000
13	909 5553 000	1	COVER TANKS	
14	909 5578 000	1	HOSE SUCTION	
15	909 5065 000	1	FILTER ANTIFOAMING	OPTION TSB IT 2008-002
12B	909 6061 000	1	TANK RECOVERY KIT	TSB IT 2006-001

Recovery tank - from Serial no. 054418642

BA 410

24-07-2012

Part List ID
E79109

9

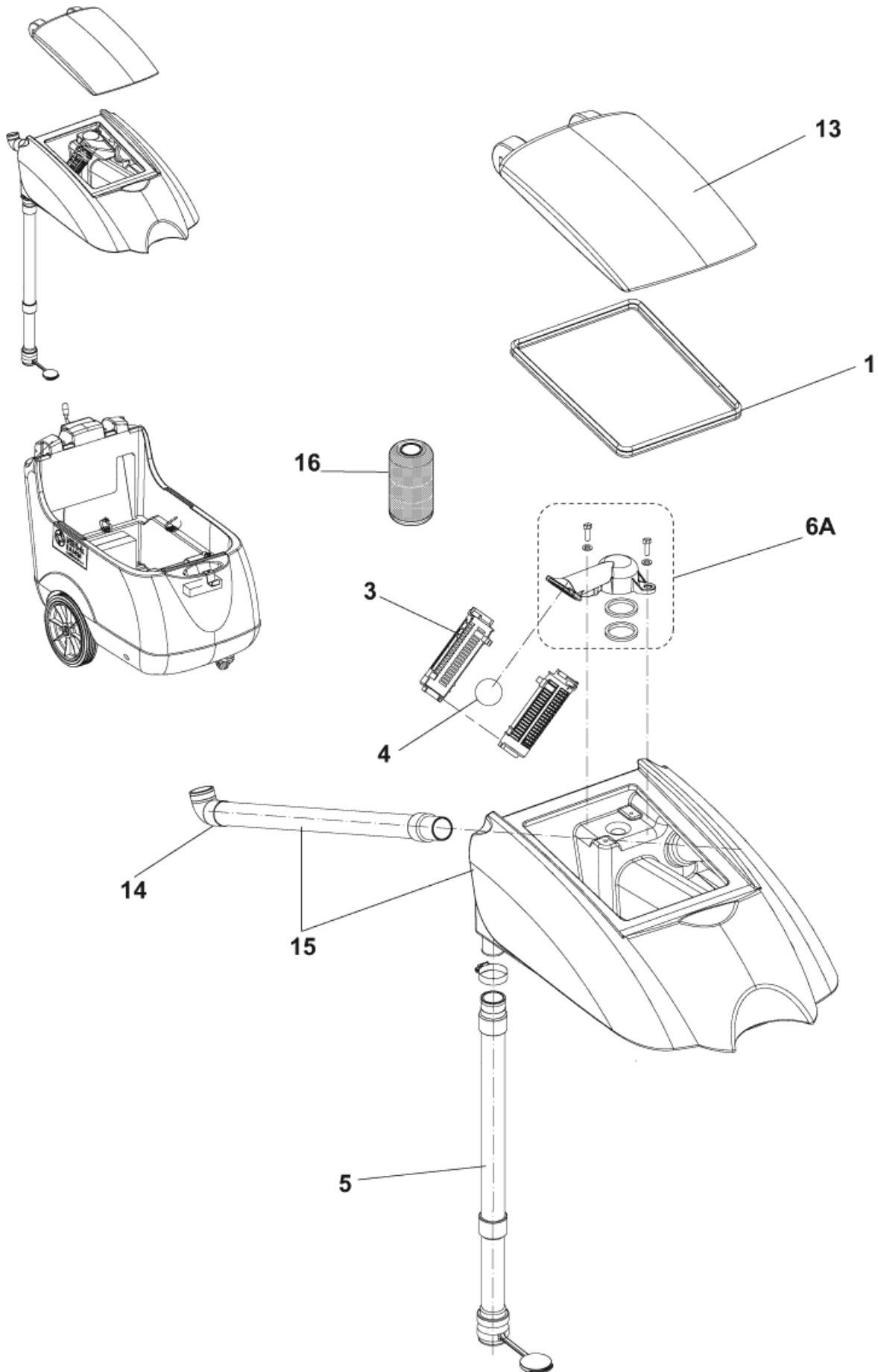

Recovery tank - from Serial no. 054418642

BA 410

24-07-2012

Part List ID E79109

10

Pos	Part no.	Qty	Description	
0	909 5988 000	1	HARDWARE. TANK FIXING KIT	
1	909 5716 000	1	GASKET	
3	L08812259	2	CAGE.FLOAT CPL	
4	L08812373	1	BALL FLOATING	
5	9099687000	1	HOSE DRAIN	
13	909 5553 000	1	COVER TANKS	
14	909 6060 000	1	HOSE.SUCTION	
15	909 6061 000	1	TANK RECOVERY KIT	TSB IT 2006-001
16	909 5065 000	1	FILTER ANTIFOAMING	OPTION TSB IT 2008-002
6A	9097681000	1	CAGE FLOAT HOLDER KIT	TSB IT 2008-009 - INSTR.CODE 9097680000

Handle assembly

BA 410

24-07-2012

Part List ID
E79111

11

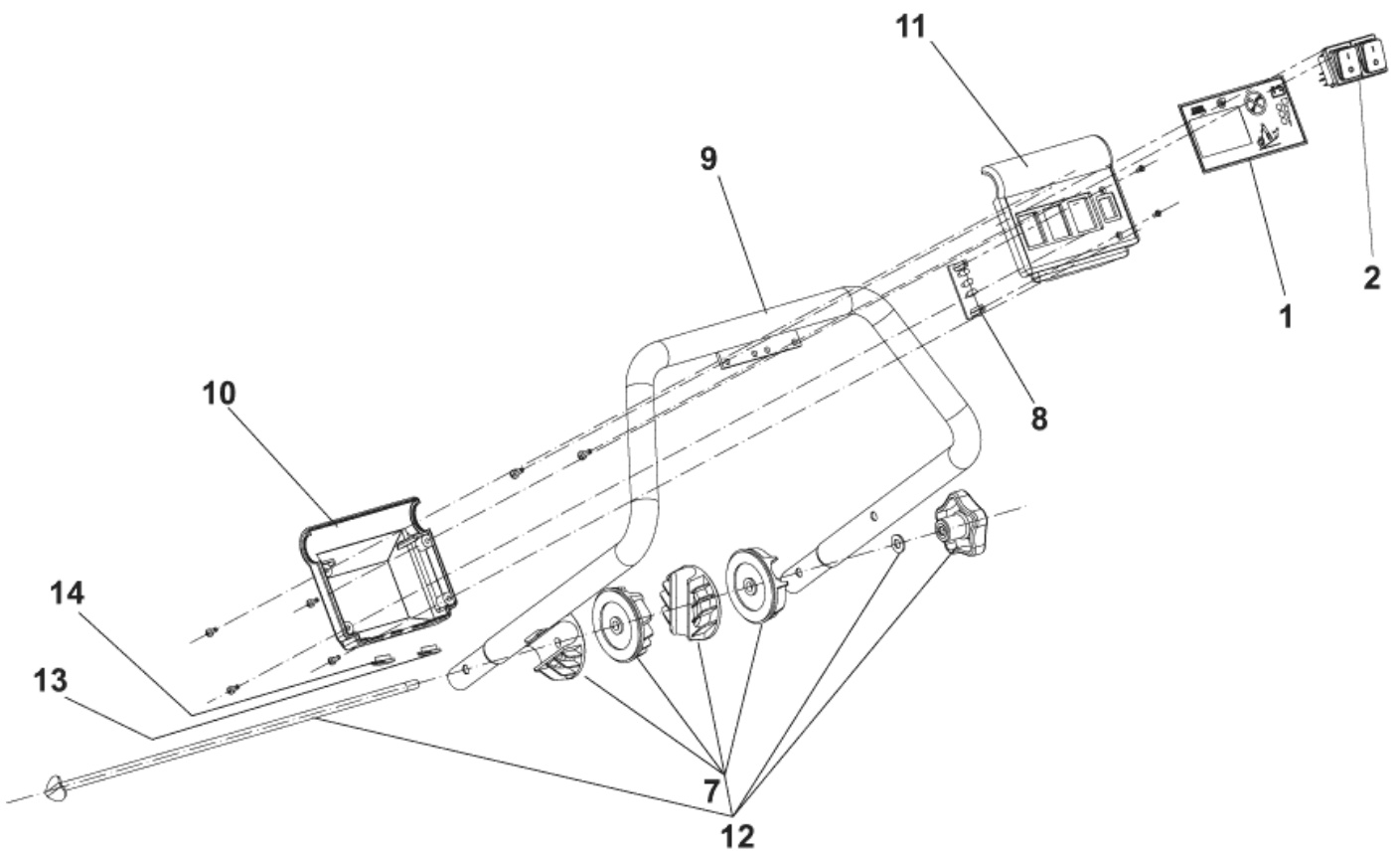
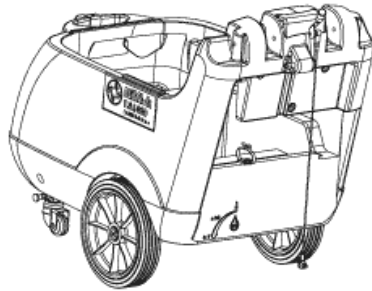
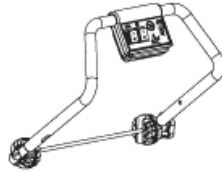

Handle assembly

BA 410

24-07-2012

Part List ID E/9111

12

Pos	Part no.	Qty	Description
0	909 5995 000	1	HARDWARE. HANDLE FIX. KIT
1	909 5587 000	1	DECAL CONTROL PANEL
2	909 5584 000	2	SWITCH
7	909 5099 000	1	RATCHET HANDLE ADJUST.KIT
8	L08812909	1	BOARD. LED
9	909 6579 000	1	HANDLE BAR
10	909 5847 000	1	HOUSING SWITCH LOWER
11	909 5846 000	1	HOUSING SWITCH UPPER
12	909 5701 000	1	HANDLE ADJUSTER KIT
13	145 4260 000	1	CAP D.14.7
14	145 4259 000	1	CAP. BLACK D.11.9

Solution system

BA 410

24-07-2012

Part List ID
E79113

13

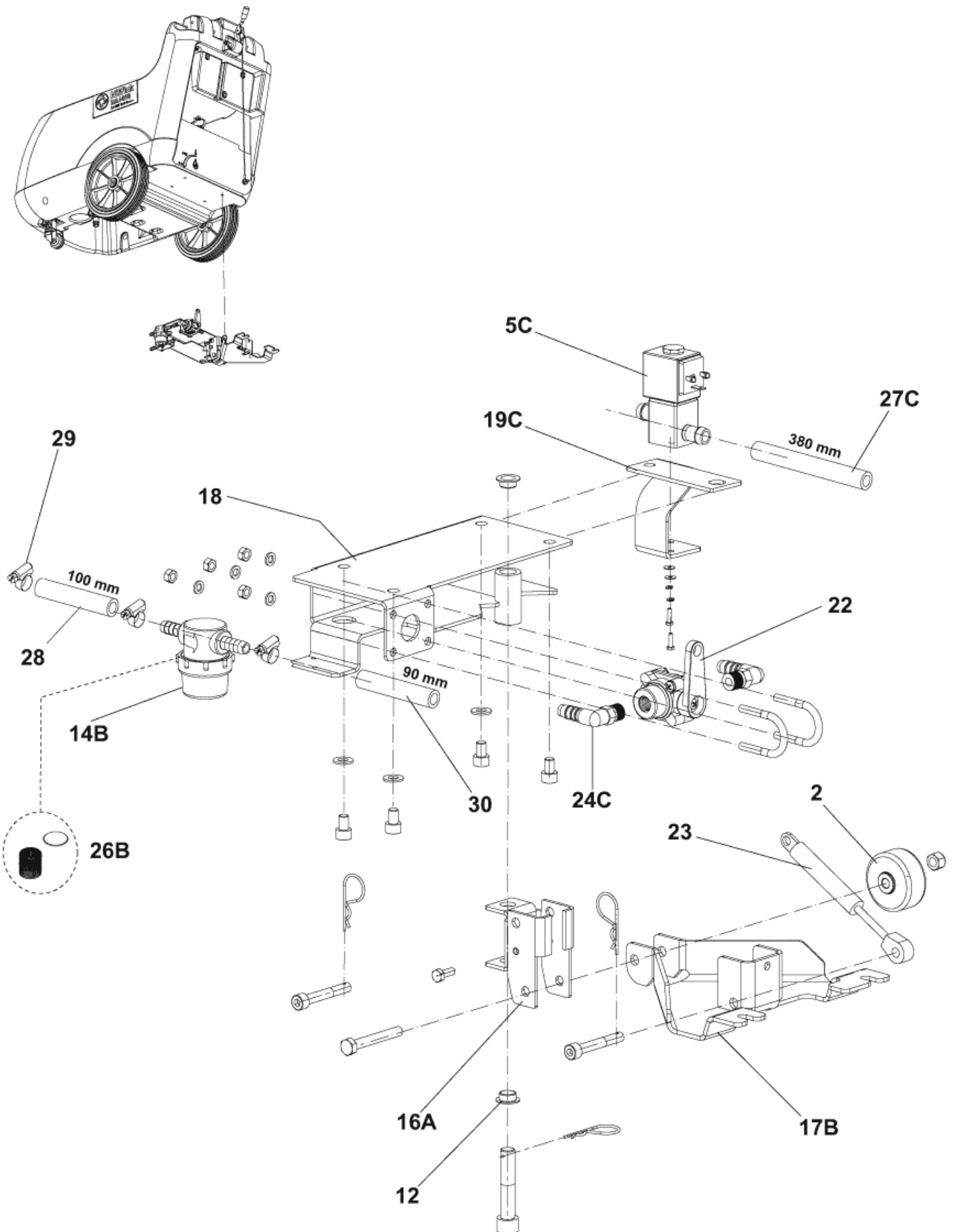

Solution system

BA 410

24-07-2012

Part List ID
E/79113

14

Pos	Part no.	Qty	Description	
0	909 5990 000	1	HARDWARE. SOL.VAL.FIX.KIT	
2	L08603665	1	WHEEL D.51.SQUEEGEE	
0C	9097874000	1	CONNECTOR TYPE DIN 43650	See TSB IT 2008-016
12	146 0549 000	2	BUSH FLANGED	
18	909 5571 000	1	PLATE	
22	909 5632 000	1	VALVE 1/4 FOR SOLEN.VALVE	
23	909 5637 000	1	SPRING GAS	
28	909 5026 000	1	HOSE D.10 L100	
29	145 8582 000	3	CLAMP 8/ 9-16	
30	145 4154 000	1	PIPE D.10 L 90	
5C	909 5977 000	1	SOLENOID VALVE KIT	See TSB IT 2008-016 - Before Serial No. 084834866
5C	9099423000	1	SOLENOID VALVE 24V KIT	
5C	9099423000	1	SOLENOID VALVE 24V KIT	See TSB IT 2008-016
14B	9097166000	1	FILTER COMPLETE KIT	See TSB IT 2007-021
16A	909 5566 000	1	BRACKET SQUEEGEE SUPPORT	See TSB IT 2007-015
17B	909 5567 000	1	SUPPORT SQUEEGEE	See TSB IT 2007-021
19C	9097866000	1	BRACKET SOLENOID VALVE	See TSB IT 2008-016
24C	909 5651 000	2	HOLDER RUBBER 90. D.10	See TSB IT 2008-016
26B	L08603893	1	NET FILTER WITH GASKET KIT	See TSB IT 2007-021
27C	9097868000	1	HOSE D.12 L380MM	See TSB IT 2008-016

Squeegee assembly

BA 410

24-07-2012

Part List ID
E79115

15

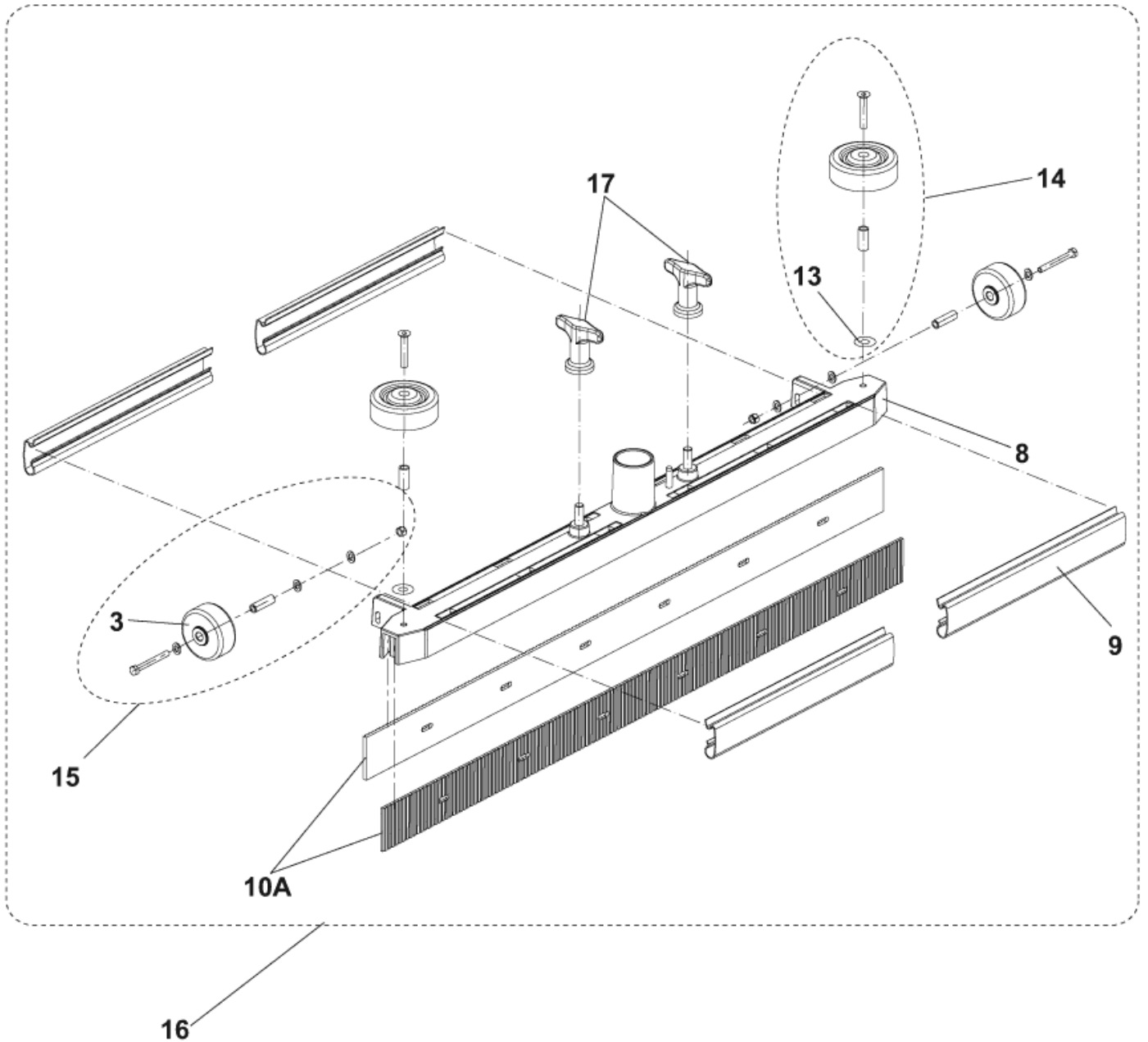
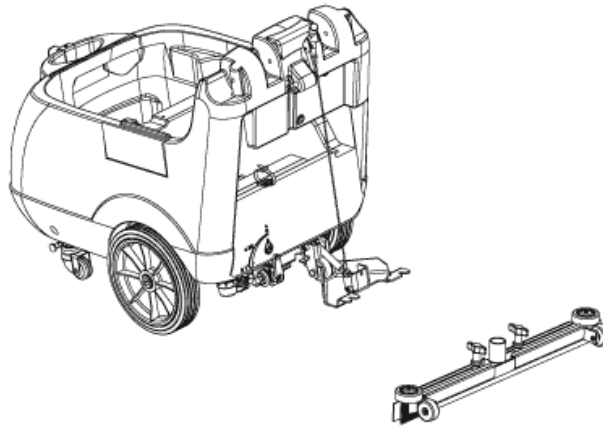

Squeegee assembly

BA 410

24-07-2012

Part List ID E/79115

16

Pos	Part no.	Qty	Description
0	909 5991 000	1	HARDWARE.SQUEEGEE FIX.KIT
3	L08603665	2	WHEEL D.51.SQUEEGEE
8	909 5554 000	1	WELDMENT SQUEEGEE TOOL
9	909 5555 000	4	SPRING
13	L08603689	2	WASHER 6X18X1.5 UNI6593 SS
14	L08603880	1	ROLLER BUMPER KIT
15	909 5703 000	1	WHEEL SQUEEGEE KIT
16	909 5702 000	1	SQUEEGEE CPL STR.740MM/29 KIT
17	9097637000	1	SQUEEGEE FIXING KIT
10A	9097354000	1	BLADES PU KIT 720MM/28

Brush system - before Serial no. 054920336

BA 410

24-07-2012

Part List ID

E79117

17

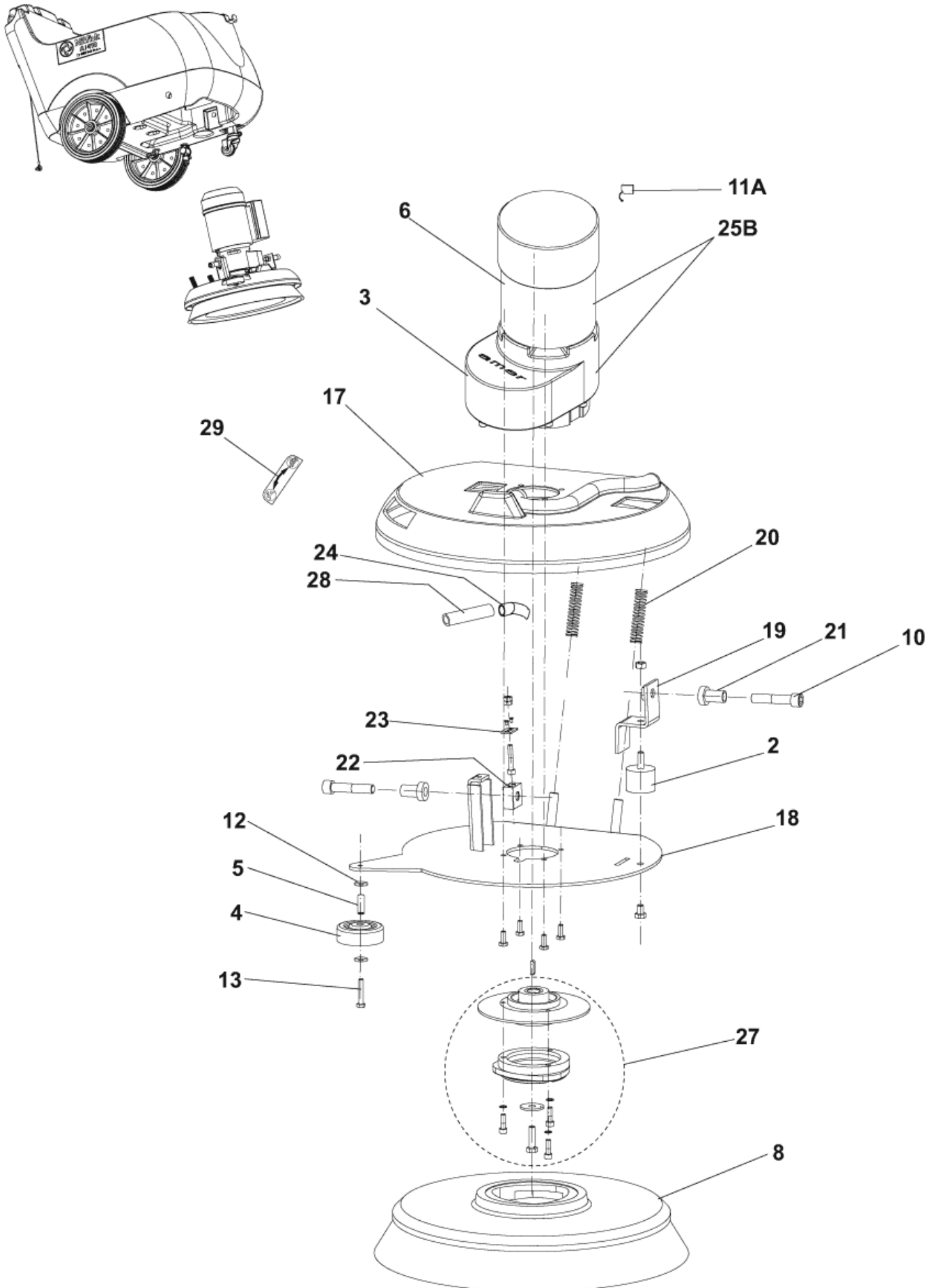

Brush system - before Serial no. 054920336

BA 410

24-07-2012

Part List ID E79117

18

Pos	Part no.	Qty	Description	
0	145 9774 000	1	KEY 5X5X20 UNI6604A	For GEAR REDUCTION 1 19
0	909 5992 000	1	HARDWARE.BRUSH FIXING KIT	
2	9097184000	1	VIBRATION DAMPING M8 60SH	
3	L08603849	1	GEAR REDUCTION 1 19	SEE TSB IT 2007-011
4	L08602460	1	ROLLER BUMPER	
5	909 5710 000	1	SPACER 6.5X9.5X24	
6	9097114000	1	MOTOR ELECTRIC 520W 24V	SEE TSB IT 2007-011
8	L08812891	1	BRUSH D.430 PROLENE PPL	
10	146 2826 000	2	SCREW M12X55 UNI5931	
12	L08228600	2	WASHER 6X18 UNI6592	
13	33003978	1	SCREW M6X35 UNI5739	
17	909 5550 000	1	GUARD BRUSH	
18	909 6269 000	1	PLATE.BRUSH HOLDER	
19	909 6270 000	1	BRACKET	
20	909 5558 000	2	SPRING	
21	909 5559 000	2	BUSH FLANGED	
22	909 5585 000	1	BLOCK ADJUSTER BRUSH DECK	
23	909 5586 000	1	PLATE	
24	909 5594 000	1	HOSE COPPER	
27	L08812589	1	HOLDER POLYG.W/FLANGE KIT	
28	909 5622 000	1	HOSE	
29	9097769000	1	DECALS KIT BA 410	
25B	9097113000	1	MOTOR REDUCTION GEAR 520W 24V	SEE TSB IT 2007-011

Brush system - from Serial no. 054920336

BA 410

24-07-2012

Part List ID

E79119

19

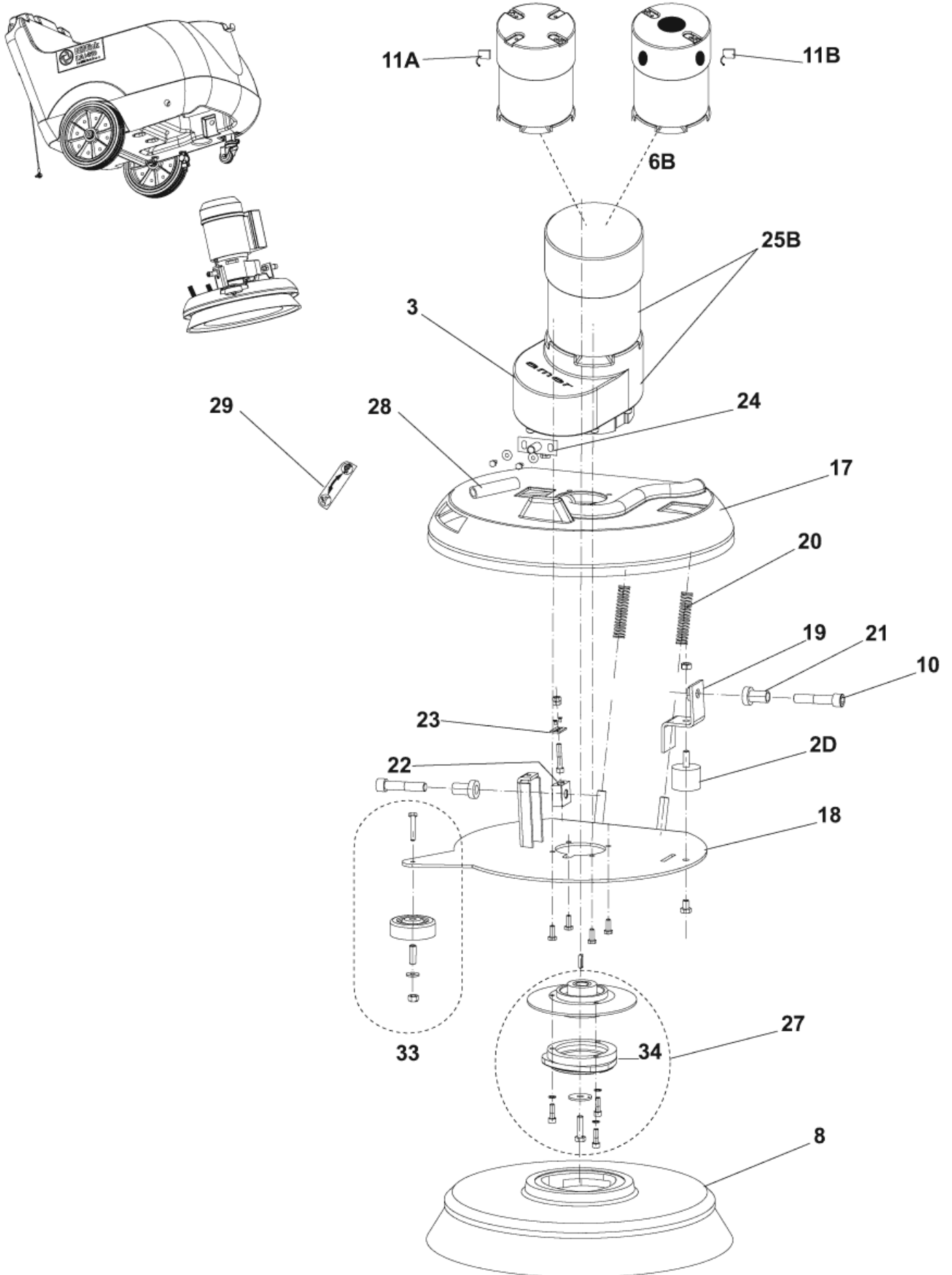

Brush system - from Serial no. 054920336

BA 410

24-07-2012

Part List ID E/79119

20

Pos	Part no.	Qty	Description	
0	145 9774 000	1	KEY 5X5X20 UNI6604A	For GEAR REDUCTION 1 19
0	909 5992 000	1	HARDWARE.BRUSH FIXING KIT	
3	L08603849	1	GEAR REDUCTION 1 19	TSB IT 2007-011
8	L08812891	1	BRUSH D.430 PROLENE PPL	
10	146 2826 000	2	SCREW M12X55 UNI5931	
17	909 5550 000	1	GUARD BRUSH	
18	909 6269 000	1	PLATE.BRUSH HOLDER	
19	909 6270 000	1	BRACKET	
20	909 5558 000	2	SPRING	
21	909 5559 000	2	BUSH FLANGED	
22	909 5585 000	1	BLOCK ADJUSTER BRUSH DECK	
23	909 5586 000	1	PLATE	
24	909 6217 000	1	HOSE COPPER	
27	L08812589	1	HOLDER POLYG.W/FLANGE KIT	
28	909 5622 000	1	HOSE	
29	9097769000	1	DECALS KIT BA 410	
2D	9097184000	1	VIBRATION DAMPING M8 60SH	
33	909 5397 000	1	ROLLER BUMPER KIT	
34	L08812480	1	HUB.BRUSH	
6B	9097114000	1	MOTOR ELECTRIC 520W 24V	TSB IT 2007-011
11B	909 6893 000	1	BRUSH CARBON KIT 4PCS	FOR NEW MOTOR
25B	9097113000	1	MOTOR REDUCTION GEAR 520W 24V	TSB IT 2007-011

Wiring system

BA 410

24-07-2012

Part List ID
E79121

21

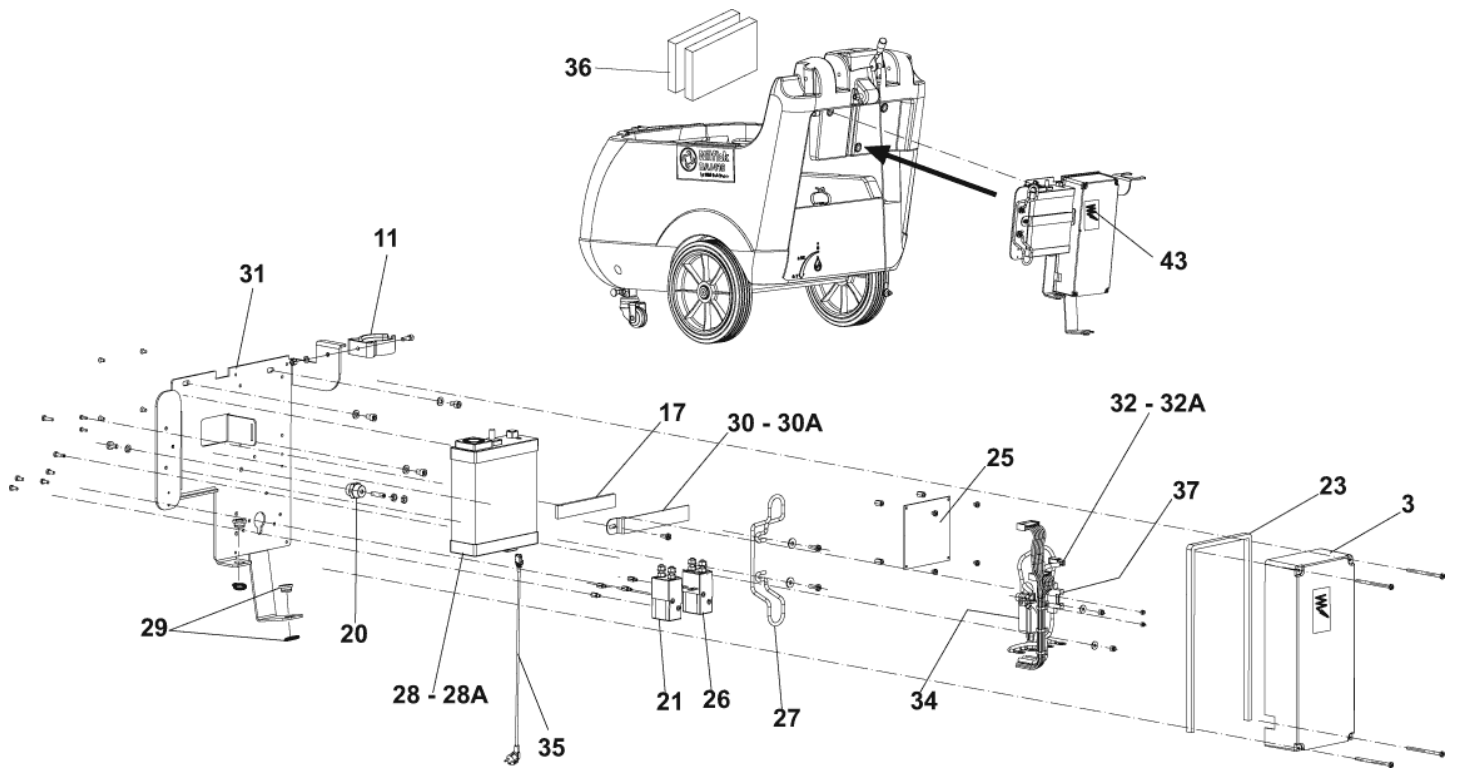

Wiring system

BA 410

24-07-2012

Part List ID
E/79121

22

Pos	Part no.	Qty	Description	
0	145 0227 000	1	FUSE BLADE 40A	
0	145 1248 000	1	CAP D. 7.9	FROM S.NO.055121383
0	145 3824 000	1	FUSE STRIP 40A	
0	145 9852 000	1	FUSE BLADE 5A UL	
0	80564200	2	BATT. 12V-50AH GEL MONOBLOC	
0	80564310	2	BATT. 12V-76AH GEL MONOBLOC	
0	909 5595 000	1	HARNESS MACHINE W CHARG.	BEFORE S.NO.084835196
0	909 5675 000	1	HARNESS MACHINE W/O CHAR	BEFORE S.NO.084835196
0	909 5994 000	1	HARDWARE. WIRING FIX. KIT	
0	909 6446 000	1	FAN COOLING	FROM S.NO.055121383
0	909 6447 000	1	COVER ABS	FROM S.NO.055121383
0	909 6448 000	1	WIRES BATT.CHARGER KIT	FROM S.NO.055121383
0	9097590000	1	CABLE BATTERY INTERCONNECTION	
0	9097971000	1	HARNESS MACHINE W/CHARGER	FROM S.NO.084835196
0	9097972000	1	HARNESS MACHINE W/O CHARGER	FROM S.NO.084835196
0	L08603889	1	HARNESS BATTERY	
3	9099432000	1	COVER ELECTRICAL BOX KIT	FROM S.NO.055121383
11	909 6380 000	1	CLAMP KIT	
17	146 0656 000	1	GASKET	
20	146 0708 000	1	INSULATOR M6 WHITE	
21	909 5127 000	1	SWITCH ELECTROMAGNETIC 24V D	
23	146 2118 000	1	GASKET	
25	909 5098 000	1	CARD ELECTRONIC	
26	146 0719 000	1	SWITCH ELECTROMAGNETIC 24V	
27	909 5149 000	1	SUPPORT CABLE	
28	9099032000	1	CHARGER BATTERY 24V 8A	FROM S.NO.055121383
29	909 6062 000	2	BUSH. KIT	
30	909 6234 000	1	BRACKET	FROM S.NO.055121383
31	909 5788 000	1	PLATE. ELECT.COMP.FIXING	
32	909 6426 000	1	HARNESS ELECTRONIC CARD	FROM S.NO.055121383
34	145 8046 000	1	HOLDER FUSE	
35	909 5633 000	1	CABLE EXTENSION	
35	909 5676 000	1	CABLE EXTENSION UK PLUG	
35	9096914000	1	CABLE EXTENSION	
36	L08812670	2	RESTRAINT. BATTERY	
37	146 0660 000	1	HOLDER FUSE	
43	9097769000	1	DECALS KIT BA 410	
28A	909 6428 000	1	CHARGER BAT.ON BOARD KIT	BEFORE S.NO.055121383

30A: SEE TSB IT 2006-002

32A: SEE TSB IT 2006-002

Accessory: Squeegee curved

BA 410

24-07-2012

Part List ID
E79129

23

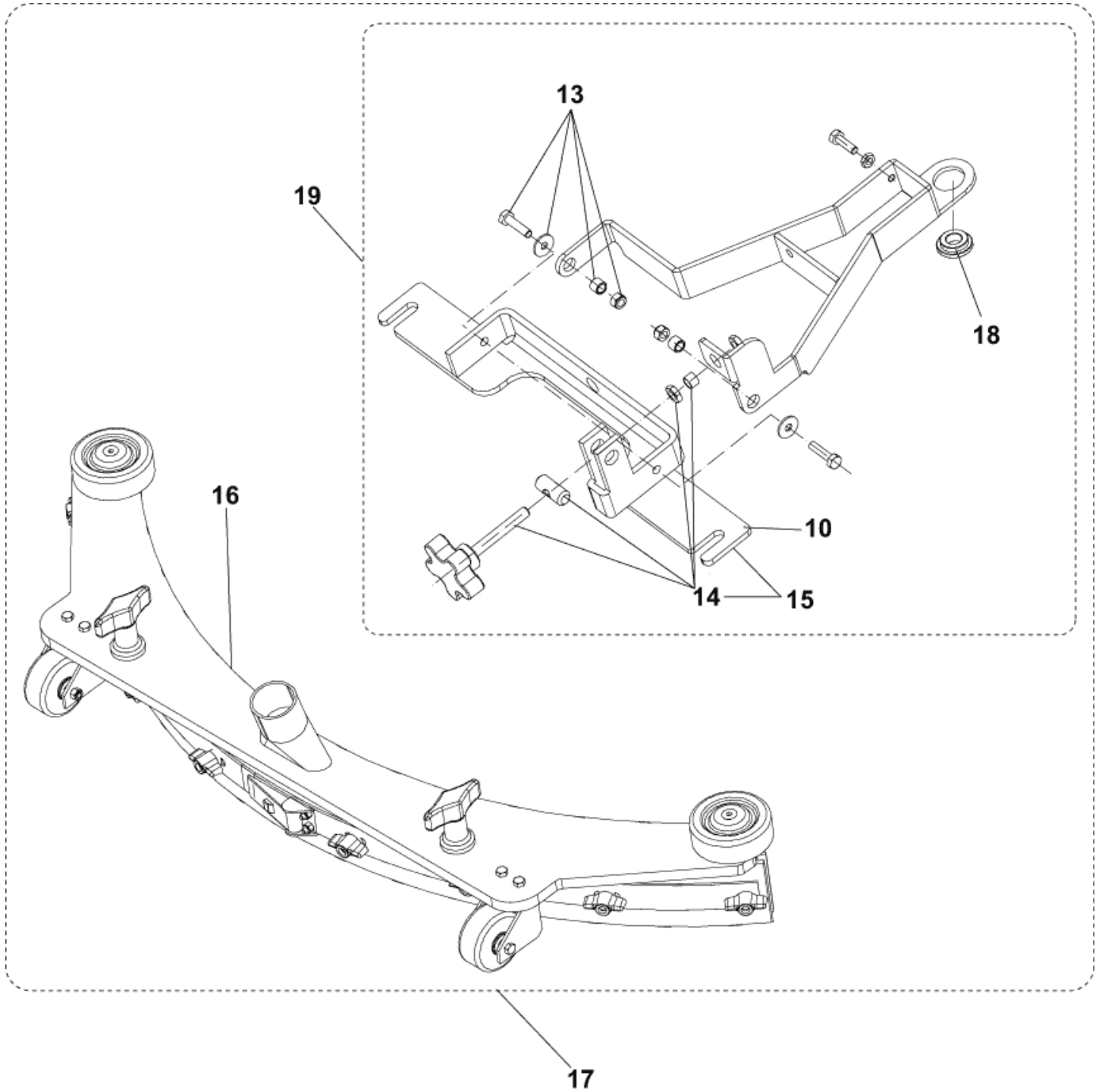

Accessory: Squeegee curved

BA 410

24-07-2012

Part List ID E/79129

24

Pos	Part no.	Qty	Description
10	L08812952	1	HOLDER SQUEEGEE
13	L08812521	1	HARDWARE SQUEEGEE FIX KIT
14	L08812518	1	SCREAS.ADJUSTING KIT
15	L08603876	1	HOLDER.SQUEEGEE KIT
16	L08603878	1	SQUEEGEE CPL KIT 30
17	909 5916 000	1	SQUEEGEE CPL KIT 30 INST.INSTR.CODE 909 5917 000
18	909 5915 000	1	SPACER
19	909 6047 000	1	SUPPORT SQUEEGEE KIT

Accessories: Brush, pad, others

BA 410

24-07-2012

Part List ID E79131

25

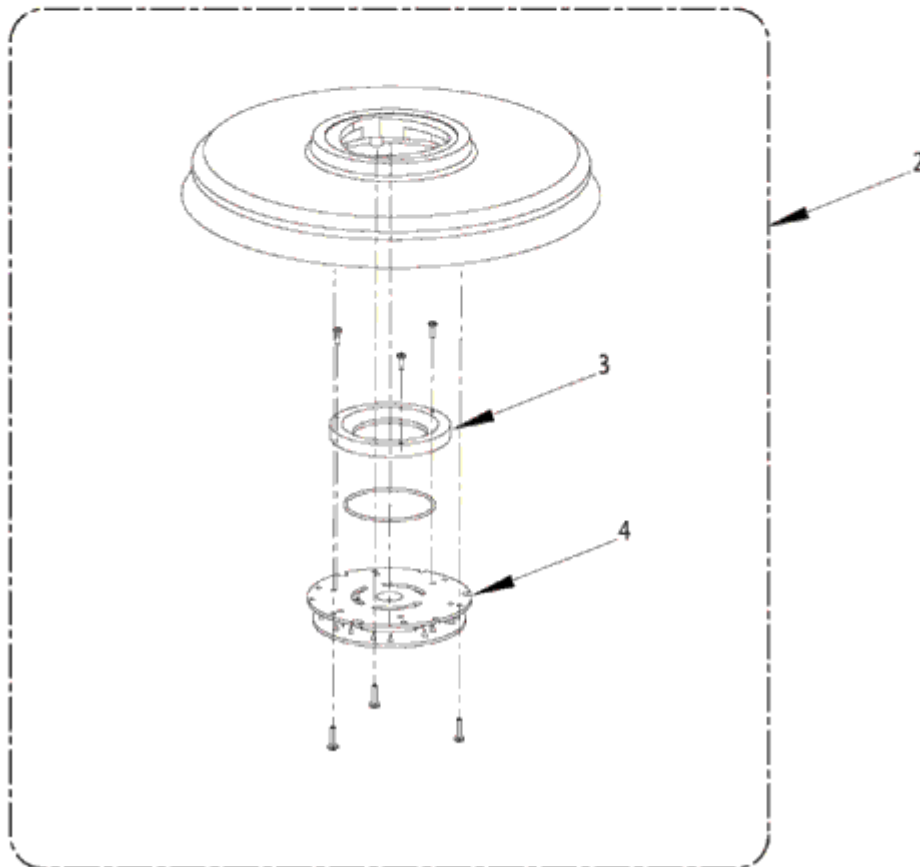
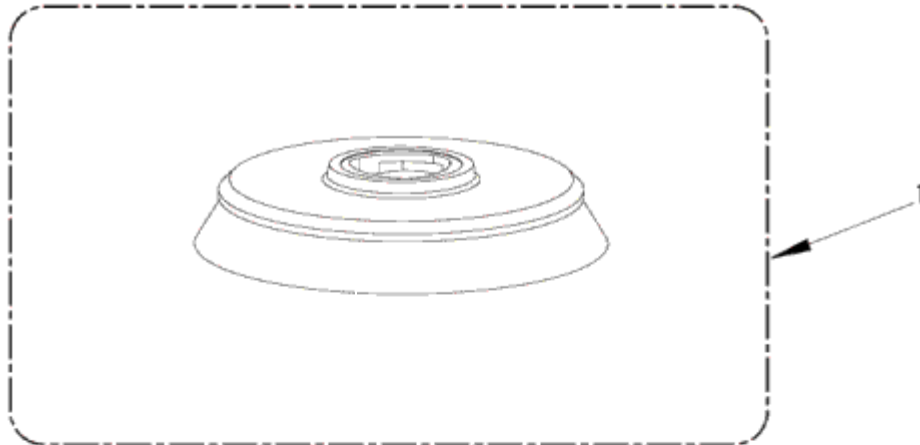

Accessories: Brush, pad, others

BA 410

24-07-2012

Part List ID E/79131

26

Pos	Part no.	Qty	Description
0	909 5065 000	1	FILTER ANTIFOAMING
0	9096916000	1	FILTER SOLUTION TANK
1	909 5691 000	1	BRUSH D.430 MIDLITE GRIT
1	909 5692 000	1	BRUSH D.430 MIDGRIT 240
1	909 5693 000	1	BRUSH D.430 PROLITE
1	909 5694 000	1	BRUSH D.430 UNION MIX
1	L08812891	1	BRUSH D.430 PROLENE PPL
2	909 5695 000	1	PADHOLDER KIT CPL 410
3	L08603966	1	RING NYLON
4	L08837030	1	RETAINER PAD

Recommended spare parts

BA 410

24-07-2012

Part List ID

E79132

27

No Drawing For Part List

Recommended spare parts

BA 410

24-07-2012

Part List ID E/79132

28

Pos	Part no.	Qty	Description
1	9097166000	1	FILTER COMPLETE KIT
2	L08603893	1	NET FILTER WITH GASKET KIT
3	909 5716 000	1	GASKET
4	9097354000	1	BLADES PU KIT 720MM/28
6	909 5555 000	4	SPRING
7	L08812891	1	BRUSH D.430 PROLENE PPL
10	9099687000	1	HOSE DRAIN
11	909 5578 000	1	HOSE SUCTION
12	909 6060 000	1	HOSE.SUCTION
13	909 5579 000	1	HOSE VACUUM MOTOR
14	145 0227 000	1	FUSE BLADE 40A
15	145 3824 000	1	FUSE STRIP 40A
16	145 9852 000	1	FUSE BLADE 5A UL
19	9099423000	1	SOLENOID VALVE 24V KIT
20	9099423000	1	SOLENOID VALVE 24V KIT
21	909 5977 000	1	SOLENOID VALVE KIT
22	909 5651 000	1	HOLDER RUBBER 90. D.10
23	909 5696 000	1	VALVE
24	909 5371 000	2	BRUSH CARBON
24	9098231000	1	CARBON BRUSH KIT 2PCS
25	909 5713 000	1	MOTOR VACUUM KIT
26	909 5371 000	2	BRUSH CARBON
27	909 5573 000	1	CABLE SQUEEGEE LIFTING
28	909 5700 000	1	CABLE SQUEEGEE LIFT KIT
29	909 5564 000	1	PIPE ACOUSTIC INSULATION
30	909 5565 000	1	PIPE ACOUSTIC INSULATION
31	9097113000	1	MOTOR REDUCTION GEAR 520W 24V
32	909 6893 000	1	BRUSH CARBON KIT 4PCS
35	9097184000	1	VIBRATION DAMPING M8 60SH
36	909 5558 000	2	SPRING
37	909 5397 000	1	ROLLER BUMPER KIT
38	9099410000	2	WHEEL D.250X50 GREY-BLACK
39	909 5099 000	1	RATCHET HANDLE ADJUST.KIT
40	909 5701 000	1	HANDLE ADJUSTER KIT
41	909 5554 000	1	WELDMENT SQUEEGEE TOOL
42	909 5702 000	1	SQUEEGEE CPL STR.740MM/29 KIT
43	909 5703 000	2	WHEEL SQUEEGEE KIT
44	L08603880	2	ROLLER BUMPER KIT
45	909 6062 000	1	BUSH. KIT
46	909 5584 000	1	SWITCH
47	909 5098 000	1	CARD ELECTRONIC

Pos. 1-7 - Wear parts

Pos. 10-16 - Ordinary maintenance

Pos. 20-51 - Extraordinary maintenance

Pos. 34: 909 5720 000 no more available see TSB IT 20011-072

Recommended spare parts

BA 410

24-07-2012

Part List ID E79132

29

Pos	Part no.	Qty	Description
48	909 6428 000	1	CHARGER BAT.ON BOARD KIT
49	9099032000	1	CHARGER BATTERY 24V 8A
50	146 0719 000	1	SWITCH ELECTROMAGNETIC 24V
51	909 5127 000	1	SWITCH ELECTROMAGNETIC 24V D

Pos. 1-7 - Wear parts

Pos. 10-16 - Ordinary maintenance

Pos. 20-51 - Extraordinary maintenance

Pos. 34: 909 5720 000 no more available see TSB IT 20011-072

Wiring diagram - before Serial no. 055121383

BA 410

24-07-2012

Part List ID E79133

30

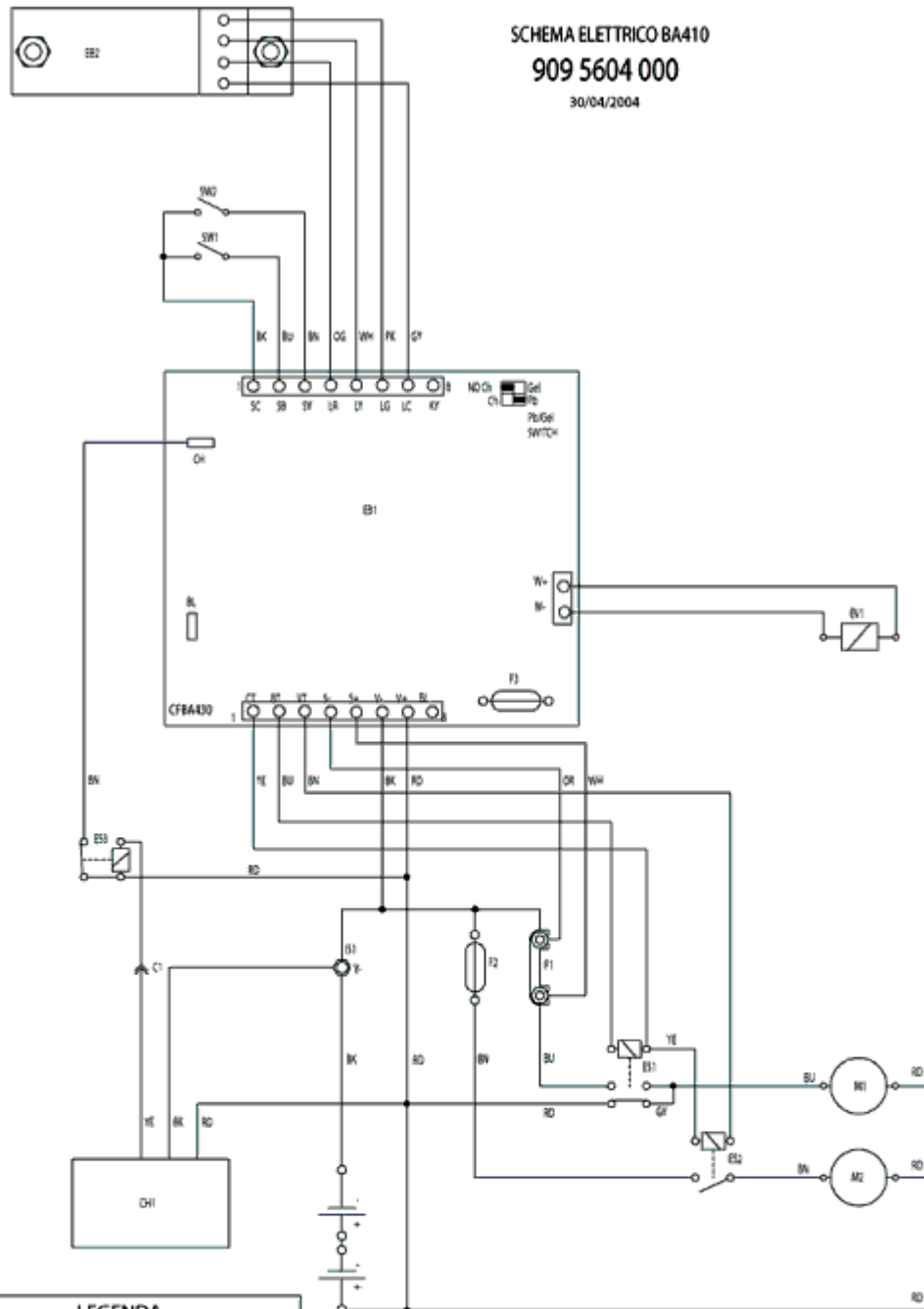

LEGENDA

CH	BATTERY CHARGER (OPT)
C1	CHARGER OUTPUT CONNECTOR (OPT)
EB1	ELECTRONIC BOARD (CFBA430)
EB2	LED BOARD (CFBALED)
ES1	BRUSH EL. SWITCH
ES2	VACUUM EL. SWITCH
ES3	CHARGER OUTPUT RELAIS (OPT)
EV1	WATER ELECTRIC VALVE
F1	BRUSH FUSE (40A)
F2	VACUUM FUSE (40A)
F3	WATER VALVE & ELECTR. FUSE (5A)
IS1	NEGATIVE INSULATOR
M1	BRUSH MOTOR
M2	VACUUM MOTOR
SW1	BRUSH SWITCH
SW2	VACUUM SWITCH

Wiring diagram - before Serial no. 055121383

BA 410

24-07-2012

Part List ID E/79133

31

Wiring diagram - from Serial no. 055121383

BA 410

24-07-2012

Part List ID
E79134

32

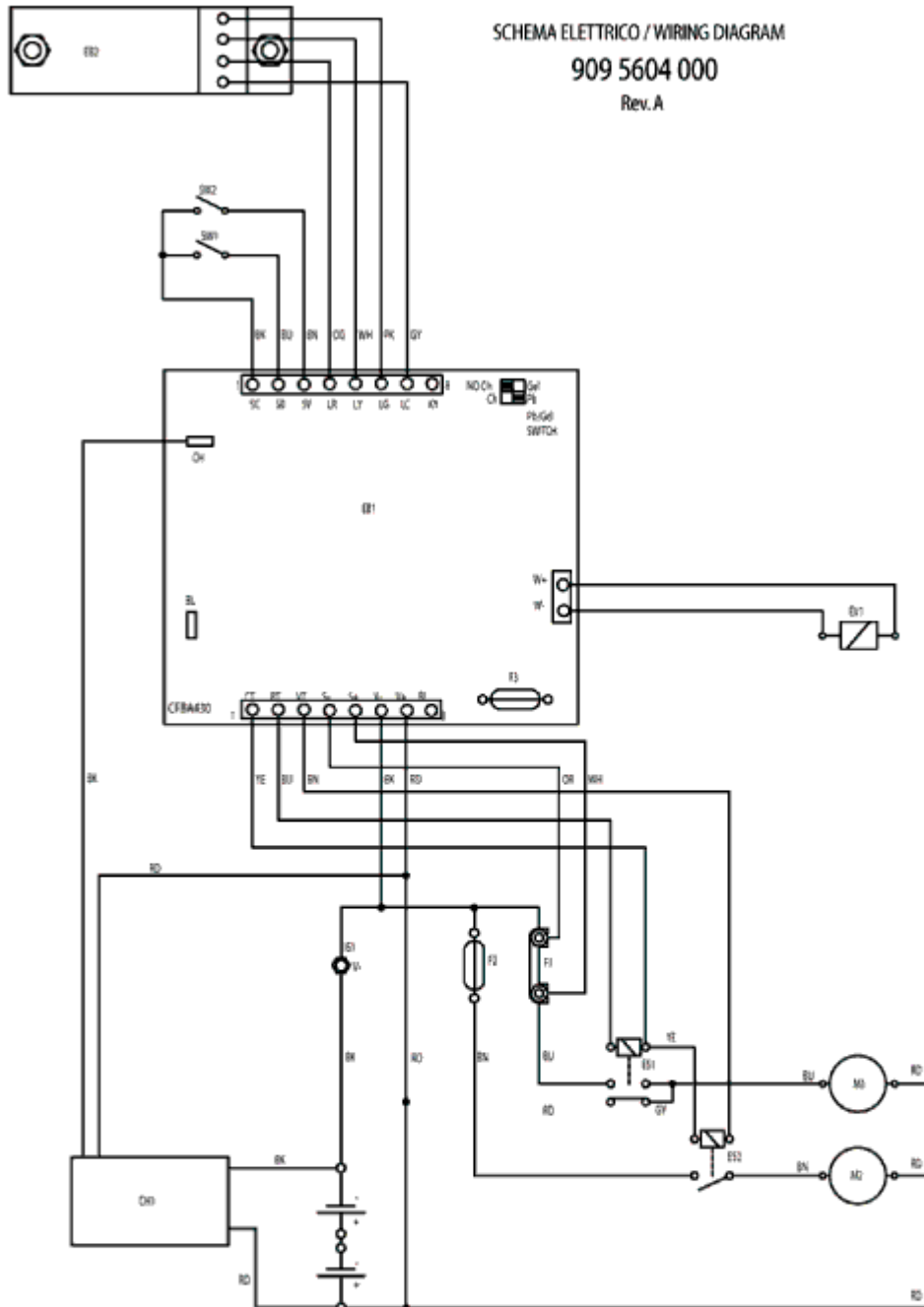

LEGENDA	
Ch	BATTERY CHARGER (OPT)
C1	CHARGER OUTPUT CONNECTOR (OPT)
EB1	ELECTRONIC BOARD (CFBA430)
EB2	LED BOARD (CFBALED)
ES1	BRUSH EL. SWITCH
ES2	VACUUM EL. SWITCH
EV	WATER ELECTRIC VALVE
F1	BRUSH FUSE (40A)
F2	VACUUM FUSE (40A)
F3	WATER VALVE & ELECTR. FUSE (5A)
IS1	NEGATIVE INSULATOR
M1	BRUSH MOTOR
M2	VACUUM MOTOR
SB1	BRUSH SWITCH
SB2	VACUUM SWITCH

COLORS CODES		
BK	BLACK	nero
BU	BLUE	azzurro
BN	BROWN	marone
GN	GREEN	verde
GY	GREY	grigio
OG	ORANGE	arancio
PK	PINK	rosa
RD	RED	rosso
VT	VIOLET	viola
WH	WHITE	bianco
YE	YELLOW	giallo

Wiring diagram - from Serial no. 055121383

BA 410

24-07-2012

Part List ID E/79134

33