

AX 300 / AX 400

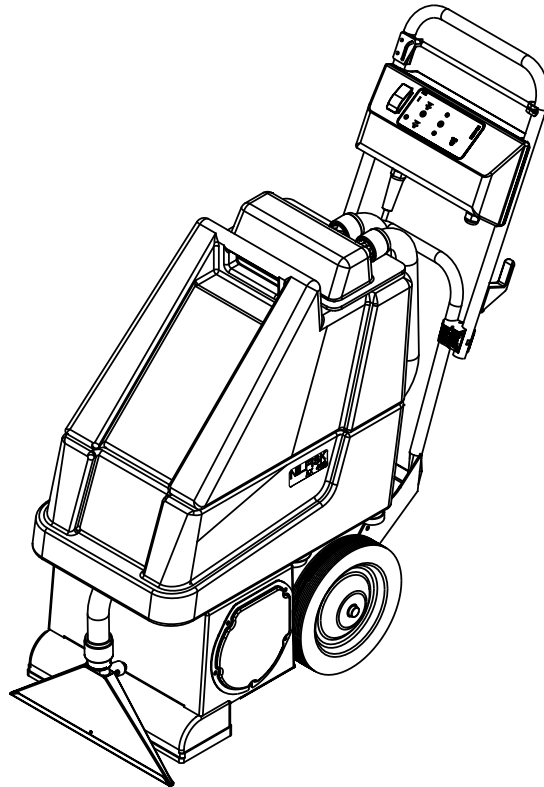

PARTS LIST

Nilfisk MODELS 56264400, 56262170, 56262171
56264401, 56262175, 56262174, 56262054,
56262055, 56262213, 56262214, 56264466

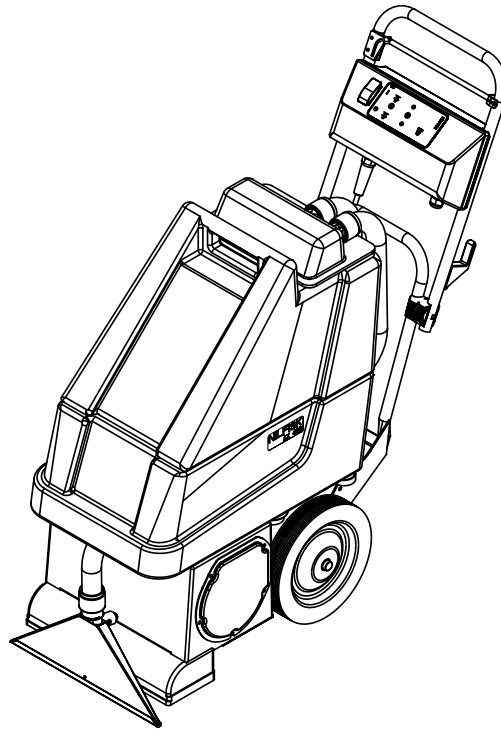

DESCRIPTION	PLAN
Upper Handle System	C-1.3.1-3
Console Assembly (Upper Handle System)	C-1.3.1-5
Lower Handle System	C-1.3.1-7
Chassis System	C-1.3.1-9
Brush System	C-1.3.1-11
Solution System	C-1.3.1-13
Flow Diverter Assembly	C-1.3.1-15
Recovery System	C-1.3.1-17
Decal System	C-1.3.1-19
Electrical System (Ladder / Harness Diagrams)	C-1.3.1-20
Optional Hard Floor Kits	C-1.3.1-25
Squeegee Mount Assembly	C-1.3.1-27
Squeegee Assembly	C-1.3.1-29
Optional Hard Floor Brushes and Accessory Tools	C-1.3.1-30
Brush Selector Guide	C-1.3.1-31

WHEN ORDERING PARTS

- * Use the 8 digit numbers from the "Ref. No." columns in this parts list.
- * Specify the model and serial number of the machine.
- * Use the space below to record the model and serial number for future reference.

Model _____ Serial No. _____

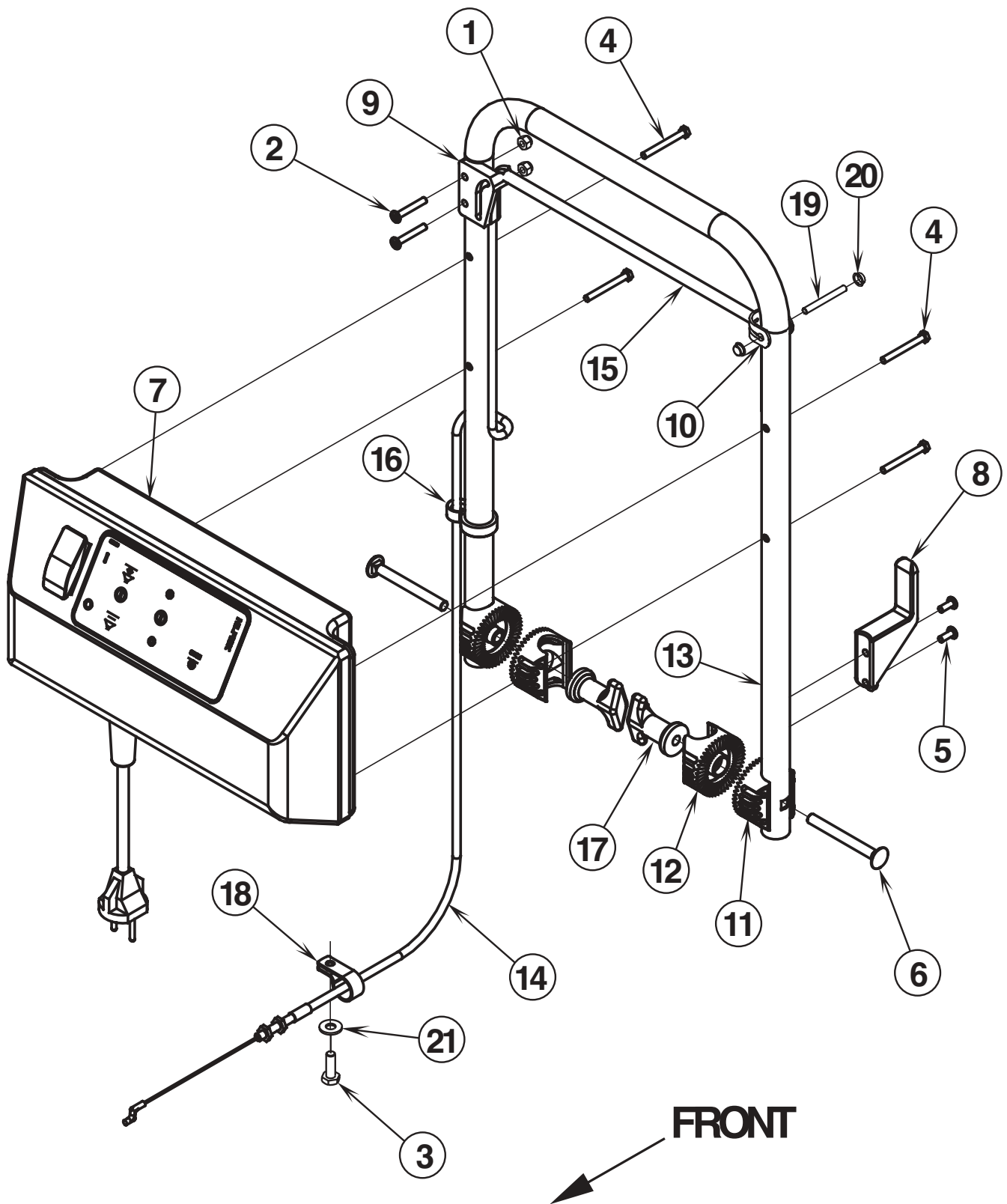

95-7	UPPER HANDLE SYSTEM	BOOK C		
02-7	AX 300 / AX 400	C	1.3.1	3

Item	Ref. No.	Qty	Description
1	56001822	2	Nut, Acorn 10-24
2	56002824	2	Scr, Pan Phil 10-24 x 1.25
3	56002948	1	Scr, Hex Hd Loc 1/4-20 x .75
4	56002020	4	Scr, Pan Phil 10-24 x 1.75
5	56009029	2	Scr, Pan Phil Thd Form 10-24 x .50
6	56009138	2	Scr, Carriage 5/16-18 x 3.25
7	56262149	1	Console Assembly (Schuko / Models 56264400 & 56264401)
	56262173	1	Console Assembly (Swiss / Model 56262171 & 56262174)
	56262169	1	Console Assembly (British / Models 56262170 & 56262175)
	56262188	1	Console Assembly (Australia Models 56262054 & 56262055)
	56262801	1	Console Assembly (Argentina Models 56262213 & 56262214)
	56264023	1	Console Assembly (Japan / Model 56264466)
8	56262518	1	Hook, Cord
9	56262570	1	Support, Cable
10	56262655	1	Clevis
11	56264118	2	Ratchet
12	56264123	2	Ratchet
13	56264142	1	Handle, Upper
14	56264146	1	Cable Assy
15	56264147	1	Tube, Handle
16	56264374	1	Support, Cable
17	56370711	2	Nut, Thumb
18	56486112	1	P Clamp
19	56262193	1	Stud
20	56009132	2	Push Cap
21	56002098	1	Wsh, Flt SAE 1/4

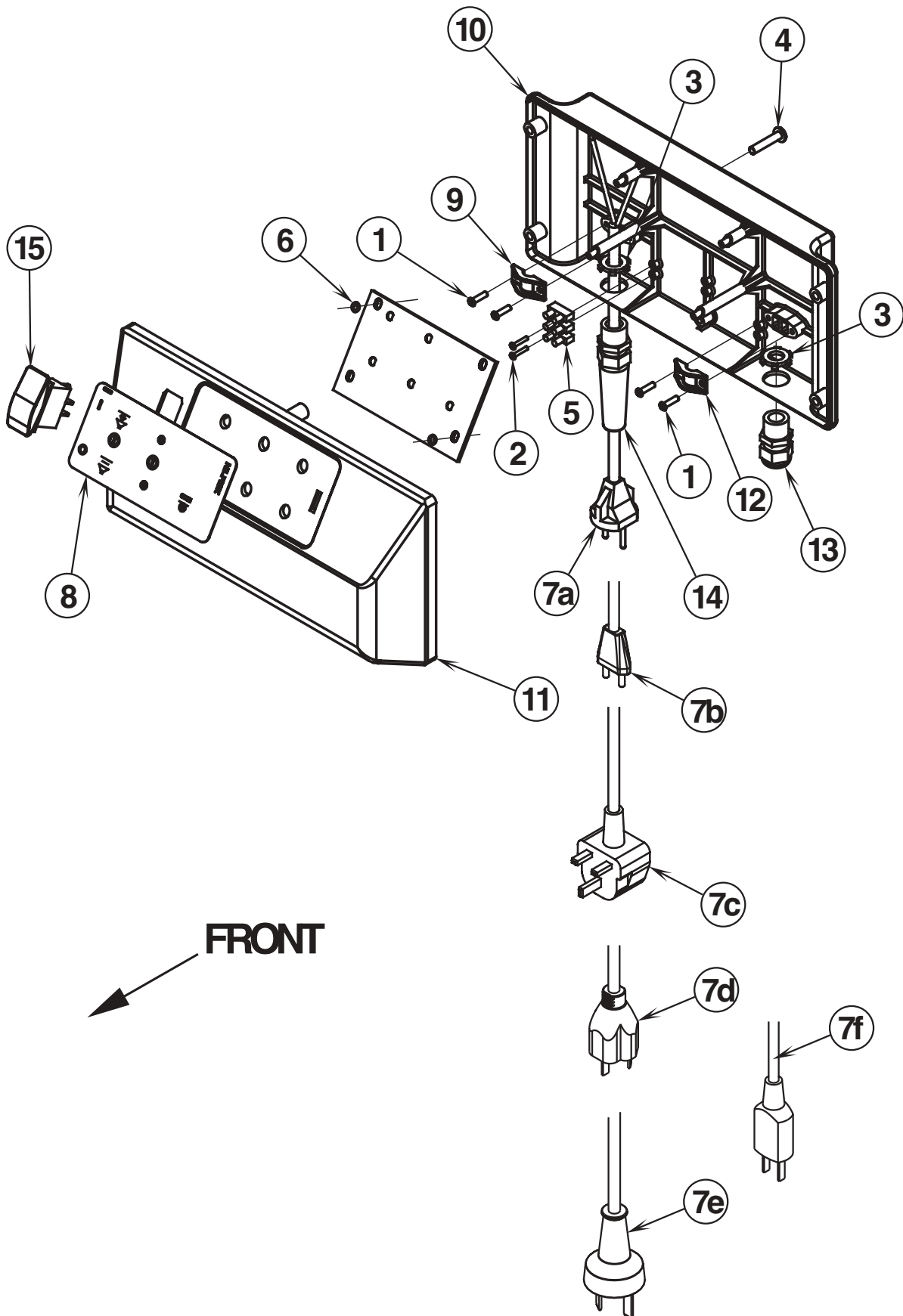

95-7	CONSOLE ASSEMBLY	BOOK C		
01-1	AX 300 / AX 400	C	1.3.1	5

Item	Ref. No.	Qty	Description
1	56002738	4	Scr, Pan Phil Plastite 8-15 x .62
2	56003092	2	Scr, Pan Phil Plastite 4-20 x .62 (240V)
3	56009095	2	Nut, Conduit Lock 1/2-14
4	56009181	2	Scr, Pan Phil Type A #12 x 1.25
5	56183523	1	Terminal Block (240V)
6	56257362	4	O-Ring (qty of 2 on 100V)
7a	56262003	1	Cord Set (Schuko / Models 56264400 & 56264401)
7b	56262172	1	Cord Set (Swiss / Model 56262171 & 56262174)
7c	56262168	1	Cord Set (British / Models 56262170 & 56262175)
7d	56262189	1	Cord Set (Australian Models 56262054 & 56262055)
7e	56330029	1	Cord Set (Argentina Models 56262213 & 56262214)
7f	56209341	1	Cord Set (Japan / Model 56264466)
8	56262009	1	Membrane Switch Assy (240V)
	56264120	1	Membrane Switch Assy (100V)
9	56262136	1	Clamp, Cord (240V)
	56262185	1	Clamp, Cord (100V)
10	56262141	1	Console, Bottom (240V)
	56264055	1	Console, Bottom (100V)
11	56262142	1	Console, Top (240V)
	56264054	1	Console, Top (100V)
12	56262185	1	Clamp, Cord (240V)
	56264119	1	Clamp, Cord (100V)
13	56323135	1	Strain Relief
14	56323136	1	Strain Relief
15	56393312	1	Switch, Rocker

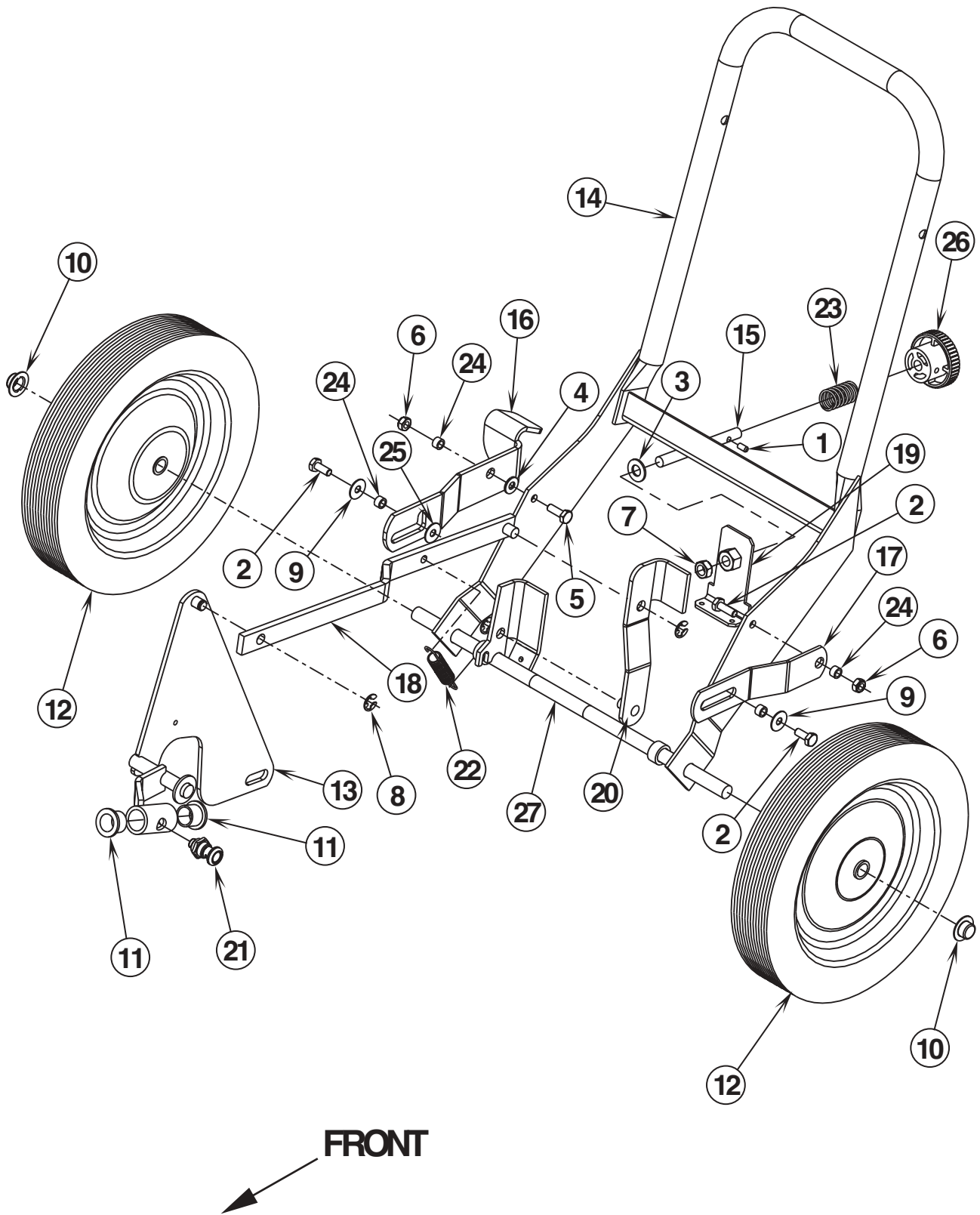

95-7	LOWER HANDLE SYSTEM	BOOK C		
02-7	AX 300 / AX 400	C	1.3.1	7

Item	Ref. No.	Qty	Description
1	56003123	1	Scr, Soc Set 10-24 x .38
2	56001836	3	Scr, Hex Hd 1/4-20 x .62
3	56002063	1	Wsh, Flt SAE 3/8
4	56002098	1	Wsh, Flt SAE 1/4
5	56002155	1	Scr, Hex Hd 1/4-20 x .75
6	56002840	2	Nut, Hex Nyl Loc-Thin 1/4-20
7	56002841	1	Nut, Hex Nyl Loc-Thin 3/8-16
8	56003262	3	Ring, Ret Ext Type E .38 Dia
9	56009025	2	Wsh, Flt .26 x .75 x .03
10	56009097	2	Nut, Push Cap 1/2
11	56171095	2	Bearing, Flange
12	56201774	2	Wheel
13	56264041	1	Lever Weld't
14	56264046	1	Axle Weld't
15	56264067	1	Screw, Adjusting
16	56264076	1	Latch
17	56264078	1	Plate, Handle Support
18	56264390	1	Linkage Weld't
19	56264443	1	Nut Plate Weldment
20	56264447	1	Lever Weldment
21	56365548	1	Lock Pin Assy
22	56370355	1	Spring
23	56377253	1	Compression Spring
24	56379298	4	Bushing
25	56388762	1	Wsh, Flt
26	56475480	1	Knob
27	56264396	1	Isolator

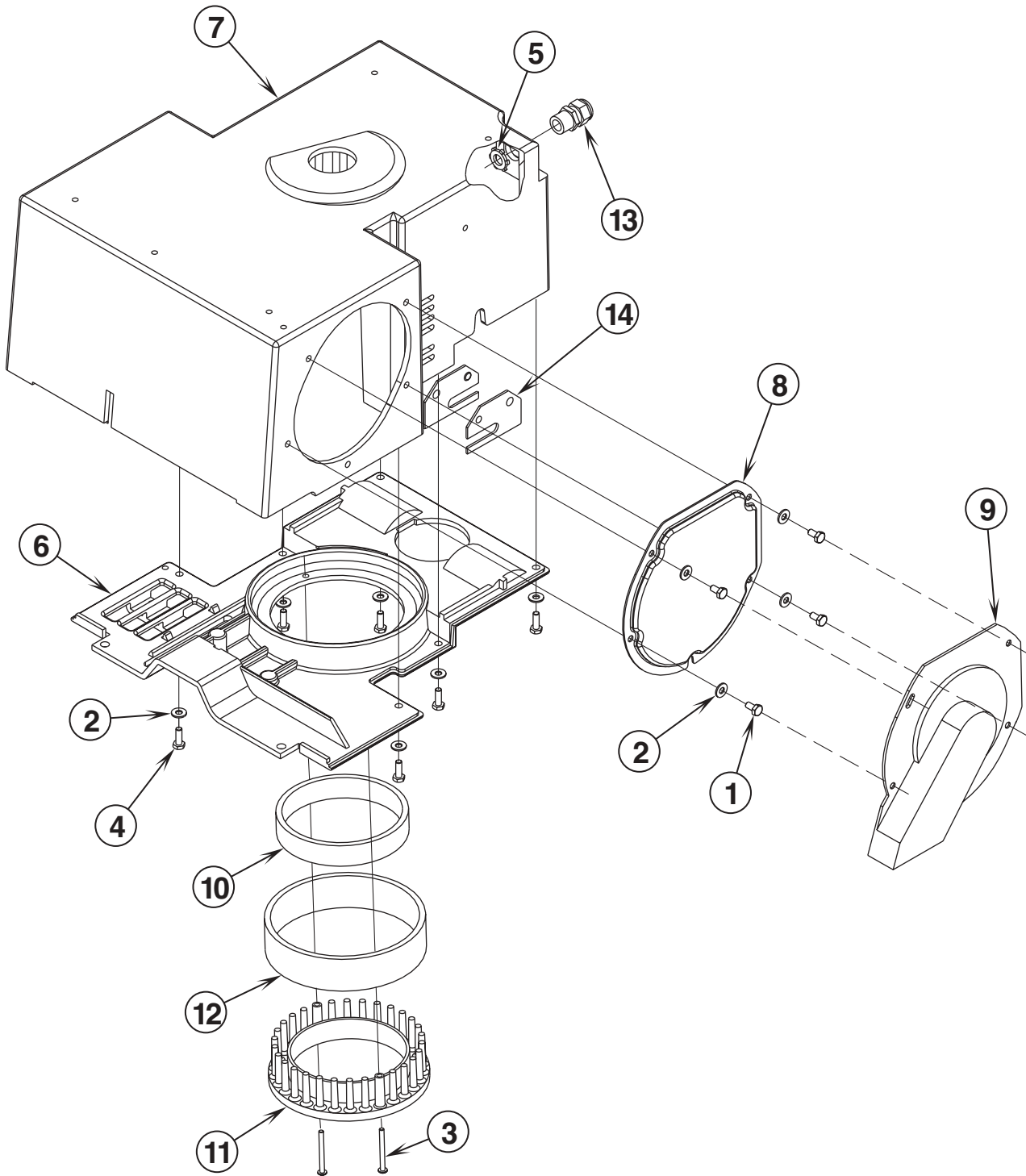

FRONT
←

95-7	CHASSIS SYSTEM	BOOK C		
02-7	AX 300 / AX 400	C	1.3.1	9

Item	Ref. No.	Qty	Description
1	56001854	4	Scr, Hex Hd 1/4-20 x .50 (Qty 5 for AX 400)
2	56002098	10	Wsh, Flt SAE 1/4 (Qty 11 for AX 400)
3	56002171	2	Scr, Pan Phil 10-24 x 2.00
4	56002948	6	Scr, Hex Hd Loc 1/4-20 x .75
5	56009095	1	Nut, Conduit Loc 1/2-14
6	56264002	1	Cover, Bottom
7	56264003	1	Chassis
8	56264072	1	Guard, Belt AX 300
9	56264051	1	Guard, Belt AX 400
10	56264327	1	Foam, Acoustical
11	56264328	1	Cap
12	56264329	1	Filter, Cooling Air
13	56323135	1	Strain Relief
14	56264004	4	Plate

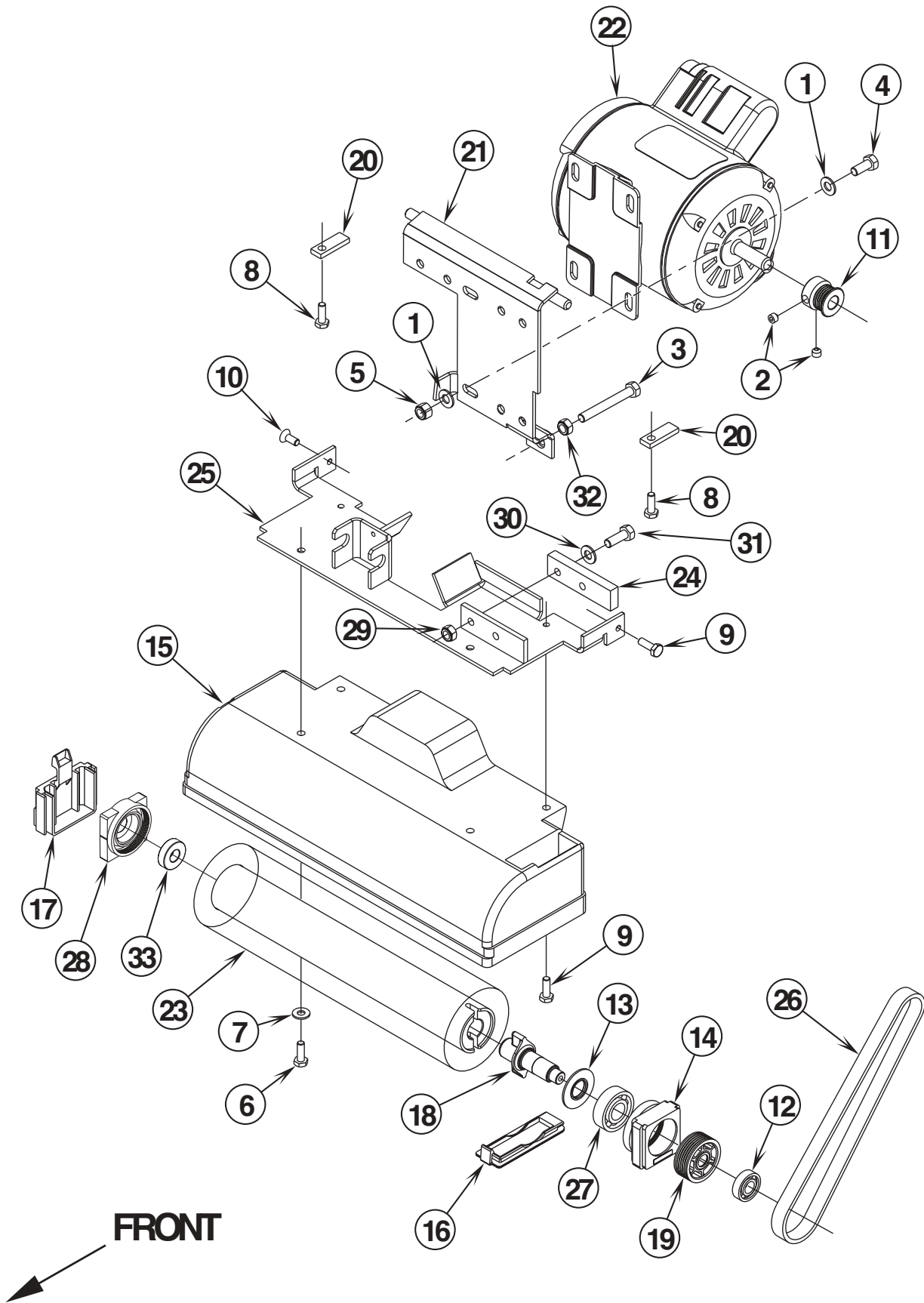

95-7	BRUSH SYSTEM	BOOK C		
02-7	AX 300 / AX 400	C	1.3.1	11

Item	Ref. No.	Qty	Description
1	56001939	6	Wsh, Flt SAE 5/16
2	56002086	2	Scr, Soc Set Loc 5/16-18 x .25
3	56002488	1	Scr, Hex Thd to Hd 5/16-18 x 2.50
4	56002667	3	Scr, Hex Hd 5/16-18 x .75
5	56002701	3	Nut, Hex Nyl Loc 5/16-18
6	56002807	2	Scr, Hex Hd SS 1/4-20 x .75
7	56002859	2	Wsh, Flt SAE SS 1/4
8	56003318	2	Scr, Hex Hd Loc 1/4-20 x 1.25
9	56009018	3	Scr, Hex Thd Form 1/4-20 x .75
10	56009137	1	Scr, Flt Phil Thd Form 1/4-20 x .62
11	56262558	1	Sheave, Poly-V
12	56262626	1	Bearing, Ball
13	56262645	1	Washer, Bearing
14	56262647	1	Bearing, Block (left side)
15	56264000	1	Brush Housing AX 300
	56264025	1	Brush Housing AX 400
16	56264459	1	Cover
17	56264016	1	End Cap, Brush
18	56264049	1	Spindle, Drive
19	56264050	1	Sheave, Poly-V 6J17
20	56264070	2	Plate, Retainer
21	56264438	1	Motor Bracket Weld't
22	56264308	1	Motor 100-115V, 1/4 HP
	56264356	1	Motor 220-240V, 1/4 HP
23	56264357	1	Carpet Brush Assy AX 300 (includes #28 & 33)
	56264358	1	Carpet Brush Assy AX 400 (includes #28 & 33)
24	56264394	1	Isolator (100V / 240V)
25	56264395	1	Bracket Weld't
26	56327476	1	Belt, Poly-V 200J6
27	56372773	1	Bearing, Ball
28	56262648	1	Bearing, Block (right side)
29	56002708	2	Nut, Hex Nyl Loc 1/4-20 (240V)
30	56002098	2	Wsh, Flt SAE 1/4 (240V)
31	56002093	2	Scr, Hex Hd 1/4-20 x 1.00 (240V)
32	56001985	1	Nut, Hex Hvy 5/16-18
33	56262626	1	Bearing, Ball

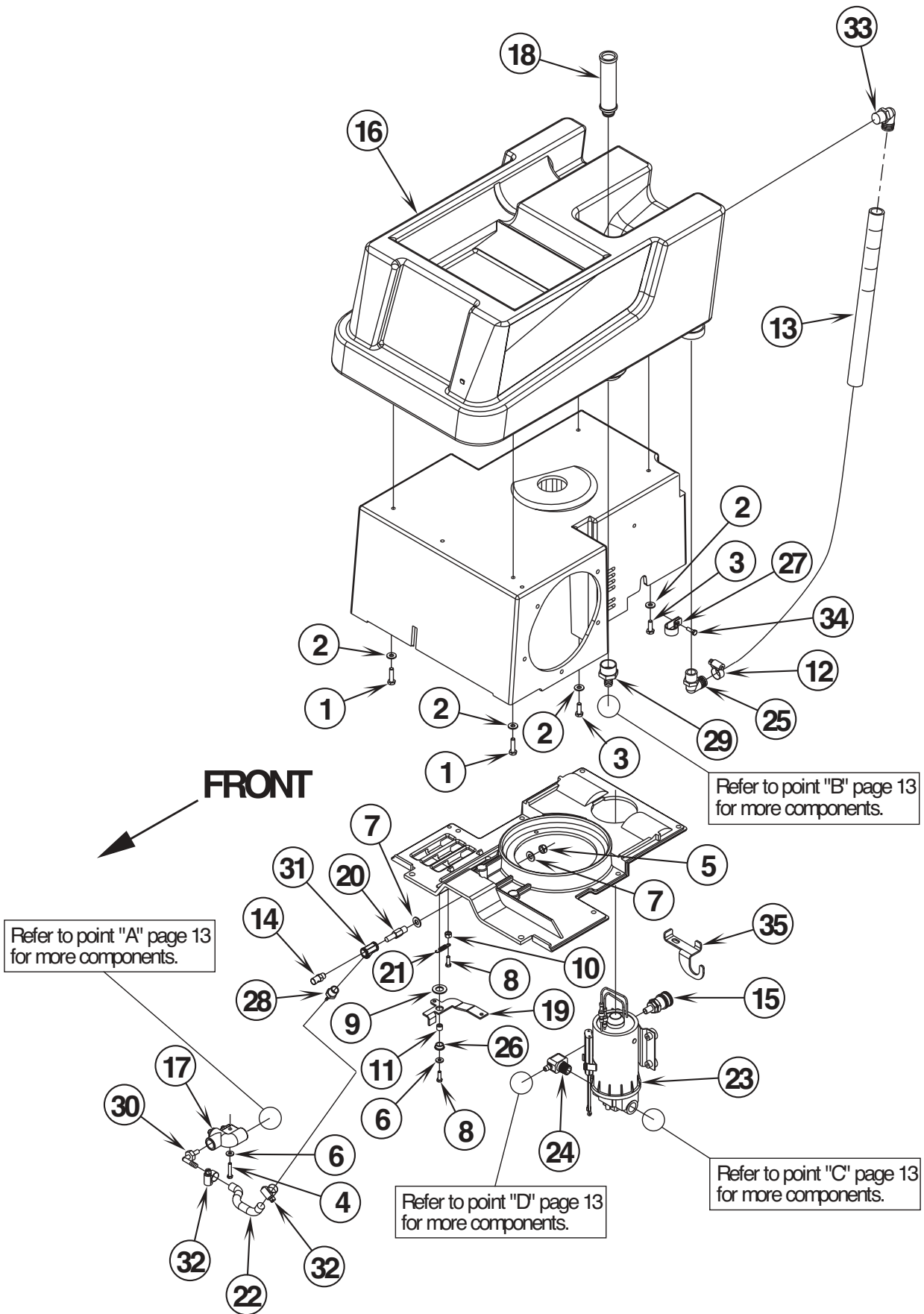

95-7	SOLUTION SYSTEM	BOOK C		
02-7	AX 300 / AX 400	C	1.3.1	13

Item	Ref. No.	Qty	Description
1	56002093	2	Scr, Hex Hd 1/4-20 x 1.00
2	56002098	4	Wsh, Flt SAE 1/4
3	56002155	2	Scr, Hex Hd 1/4-20 x .75
4	56002837	1	Scr, Hex Hd SS 10-24 x 1.00
5	56002851	1	Nut, Hex Nyl Loc-Thin SS 5/16-18
6	56002916	2	Wsh, Flt SAE SS #10
7	56002938	2	Wsh, Flt SAE SS 5/16
8	56003297	2	Scr, Hex Hd SS 10-24 x .62
9	56009003	1	Washer, Flt .51 x .93 x .07
10	56009009	1	Nut, Hex Machine
11	56200123	1	Bushing
12	56112771	1	Clamp, Hose SAE #10
13	56264462	1	Hose, Solution Gauge
14	56249334	1	Nozzle
15	56249568	1	Coupling
16	56262148	1	Tank, Solution AX 300
	56262153	1	Tank, Solution AX 400
17	56262596	1	Valve
18	56264137	1	Screen
19	56264444	1	Lever, Valve
20	56264216	1	Adapter, Nozzle, 1/8
21	56264257	1	Spring, Extension
22	56264260	1	Hose
23	56264306	1	Pump (230V)
	56264305	1	Pump (100/115V)
24	56264382	1	Adapter, Barbed TSBUS2002-819
25	56456802	1	Barb, 90° Elbow 35/64 x 3/4 NPT
26	56324505	1	Bearing, Flange
27	56328064	1	P Clamp
28	56369594	1	Barb, Adapter 1/4 x 1/8 NPT
29	56262190	1	Barb, Adapter 1/2 x 3/4 NPT
30	56470138	1	Barb, 90° Elbow 19/64 x 1/4 NPT
31	56752020	1	Tee 1/8
32	56756364	2	Clamp, Hose SAE #4
33	56264442	1	Barb, Elbow 35/64 x 3/8 NPT
34	56009135	1	Scr, Hex Thd Form 10-24 x .62
35	56264465	1	Bracket, Support TSBUS2002-819

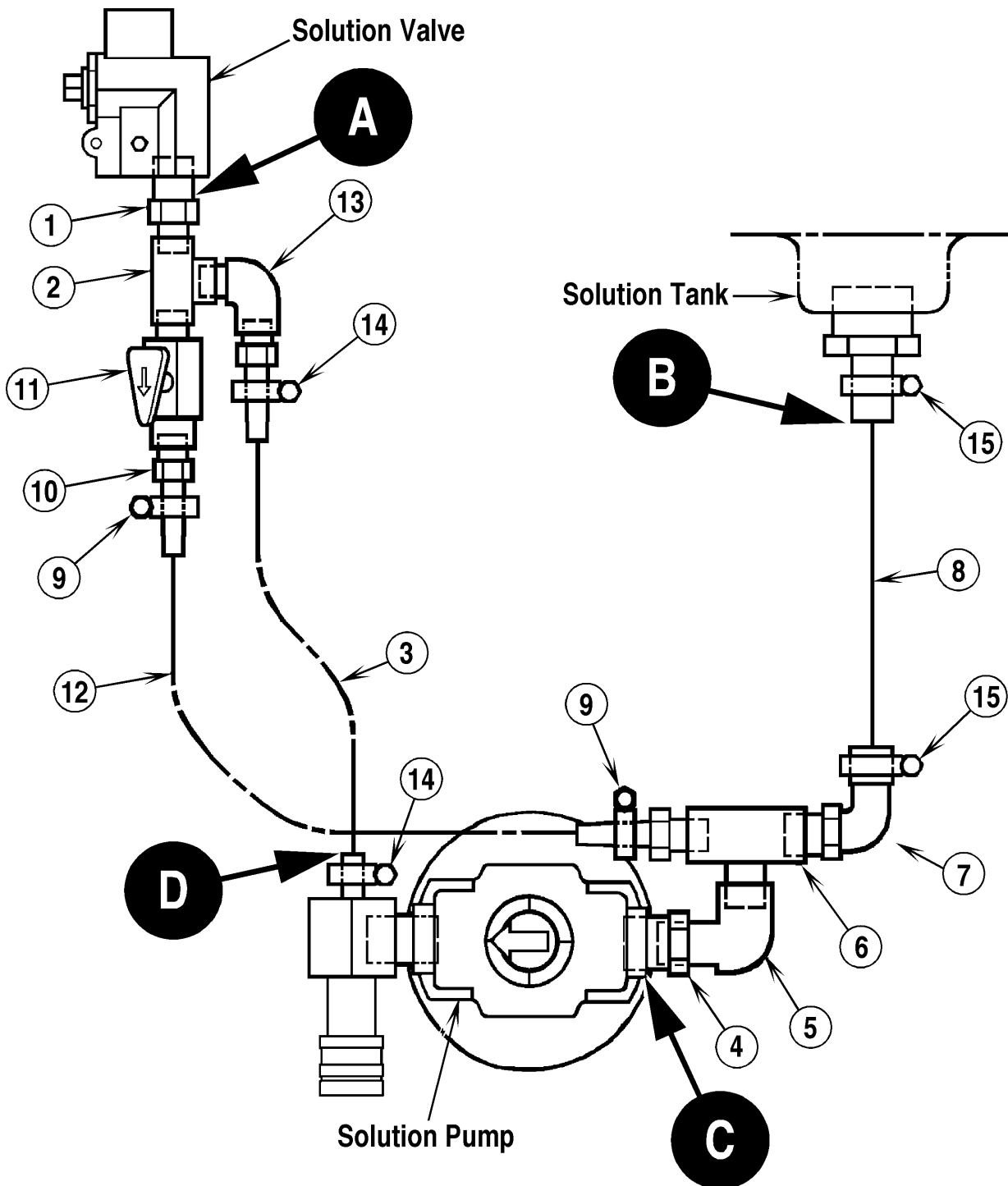

95-7	FLOW DIVERTER ASSEMBLY	BOOK C		
99-11	AX 300 / AX 400	C	1.3.1	15

Item	Ref. No.	Qty	Description
	56264347	1	Flow Diverter Assy, AX 300 (#1-13)
	56264348	1	Flow Diverter Assy, AX 400 (#1-13)
1	56900044	1	Nipple, Reducing 1/4 x 1/8
2	56752020	1	Tee, 1/8 x 1/8 x 1/8
3	56264301	1	Hose, 1/4 Braided
4	56750363	1	Bushing, Reducing 1/4 x 3/8
5	56369632	1	Elbow, Street 1/4 x 1/4
6	56372506	1	Tee, Branch 1/4 x 1/4 x 1/4
7	56263809	1	Barb, Elbow 1/4 x 1/2
8	56264318	1	Hose, 1/2 Spiral
9	56756364	2	Clamp, Hose
10	56264351	1	Barb, .25 x .14 (AX 300)
	56264352	1	Barb, .25 x .12 (AX 400)
11	56264286	1	Valve
12	56264346	1	Hose, .25 x 10.00
13	56755726	1	Barb, 1/4 x 1/8 x 90BR
14	56756364	2	Clamp, Hose SAE #4
15	56219932	2	Clamp, Hose SAE #6

* = Not Shown

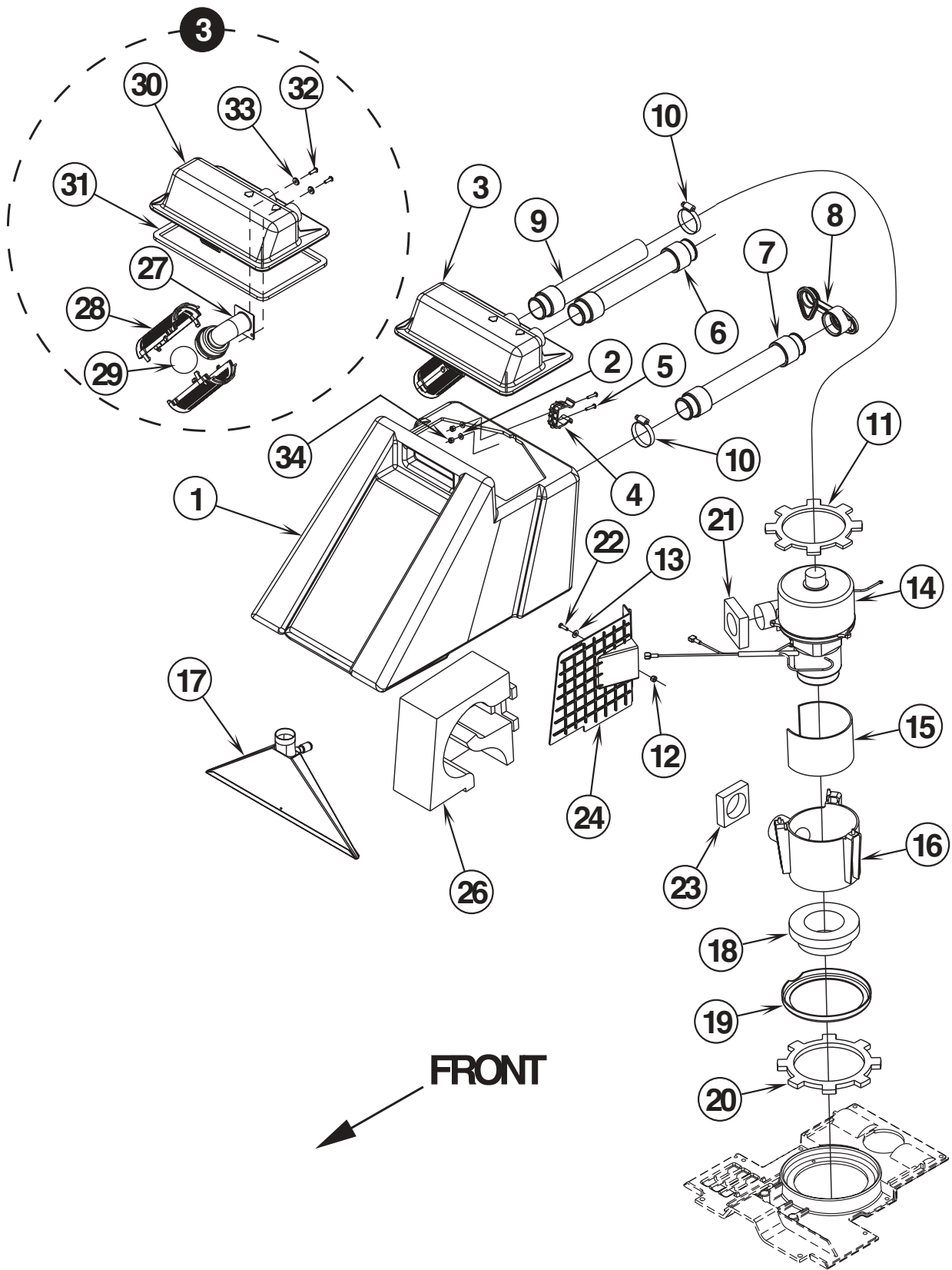

95-7	RECOVERY SYSTEM	BOOK C		
02-10	AX 300 / AX 400	C	1.3.1	17

Item	Ref. No.	Qty	Description
1	56262146	1	Tank, Recovery AX 300
	56262152	1	Tank, Recovery AX 400
2	56002875	2	Wsh, Flt SAE SS #8
3	56324045	1	Cover Assembly (items 27-33)
4	56392171	1	Clamp
5	56009186	2	Scr, Pan Phil SS 8-32 x .88
6	56392170	1	Recovery Hose Assembly
7	56262143	1	Drain Hose Assembly
8	56393772	1	Plug, Hose
9	56262147	1	Vacuum Hose Assembly
10	56329145	2	Hose Clamp
11	56264103	1	Gasket, Vacuum Motor
12	56002836	1	Nut, Hex Nyl Loc SS 10-24
13	56002053	1	Wsh, Flt SAE #10
14	56262007	1	Vac Motor Assy (230V) TSBUS2002-826
	56250201	1	Vac Motor Assy (100V) TSBUS2002-826
15	56264233	1	Foam, Accoustical
16	56264283	1	Housing, Vac Motor TSBUS2002-826
17	56264088	1	Shoe Weld't AX 300
	56264117	1	Shoe Weld't AX 400
18	56264343	1	Ring Assembly
19	56264079	1	Ring, Vac Motor
20	56264105	1	Gasket, Vacuum Motor
21	56264116	1	Gasket, Vacuum Outlet
22	56009135	1	Scr, Hex Thd Form 10-24 x .62
23	56264114	1	Gasket, Vacuum
24	56264282	1	Wall, Muffler
25			Intentionally Omitted
26	56264450	1	Muffler
27	56324298	1	Elbow, Float
28	56324497	2	Cage, Float
29	56391690	1	Ball, Float
30	56324046	1	Cover, Drilled
31	56262576	1	Gasket
32	56003633	2	Scr, Pan Phil SS Type B 10-16 x .50
33	56209261	2	Washer, Sealing 9/16
34	56002877	2	Nut, Hex Nyl Loc SS 8-32

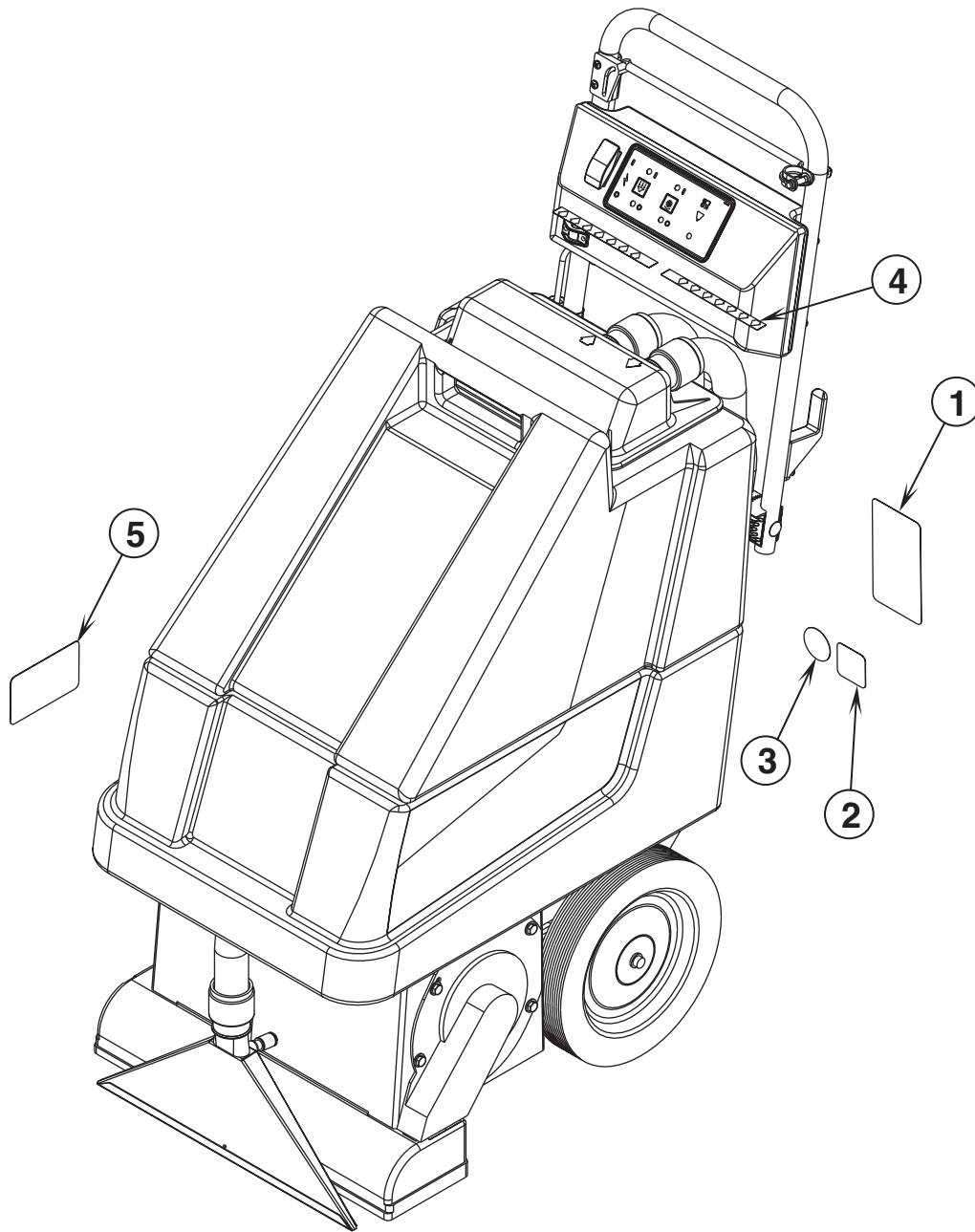

95-7	DECAL SYSTEM	BOOK C		
01-3	AX 300 / AX 400	C	1.3.1	19

Item	Ref. No.	Qty	Description
1	56014781	1	Decal, Warning
2	56015638	1	Decal, Pressure
3	56015639	1	Decal, Brush Pressure
4	56015655	2	Decal, Direction
5	56015678	1	Decal, Flow Diverter

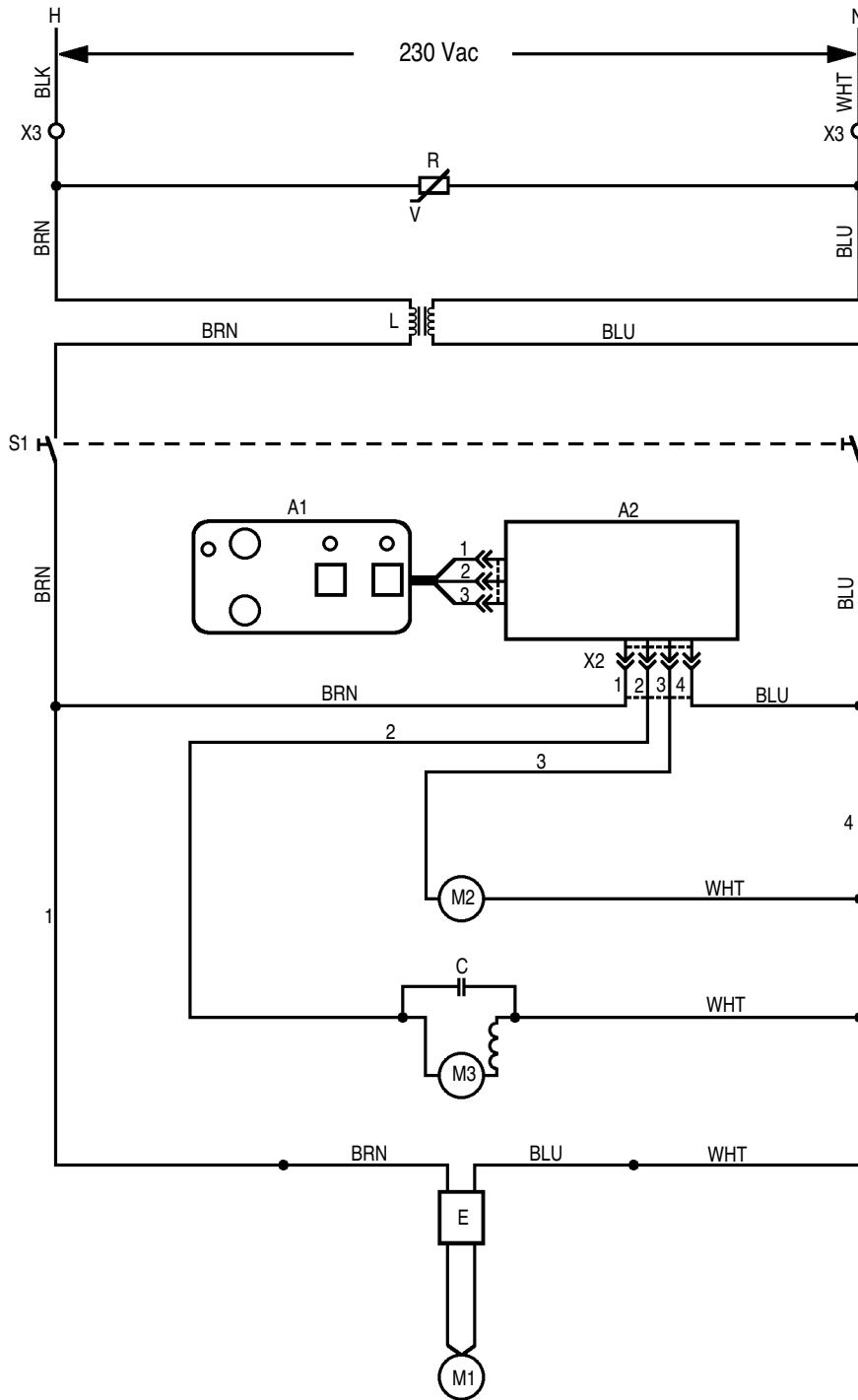

Item	Ref. No.	Qty	Description
A1	56262009	1	Membrane Switch Pad
A2	56264264	1	Controller PCB
C	56264350	1	Capacitor
E		1	RFI Filter (part of solution pump)
L	56264349	1	Choke Coil
M1	56264306	1	Solution Pump
M2	56264356	1	Brush Motor
M3	56262007	1	Vacuum Motor TSBUS2002-826
R	56264324	1	Varistor
S1	56393312	1	Main Switch
X2		1	Controller PCB Connector
X3	56183523	1	Terminal Block

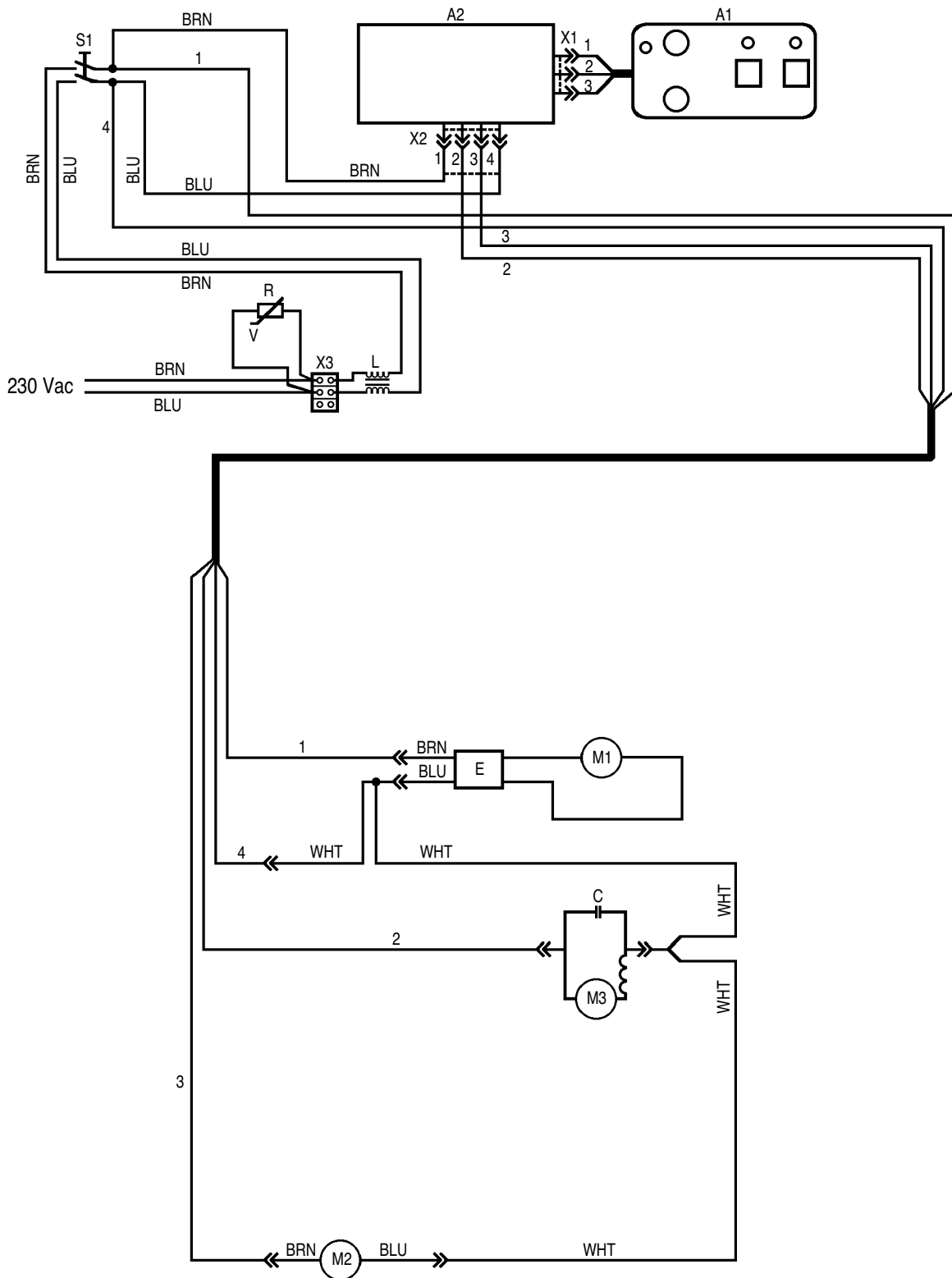

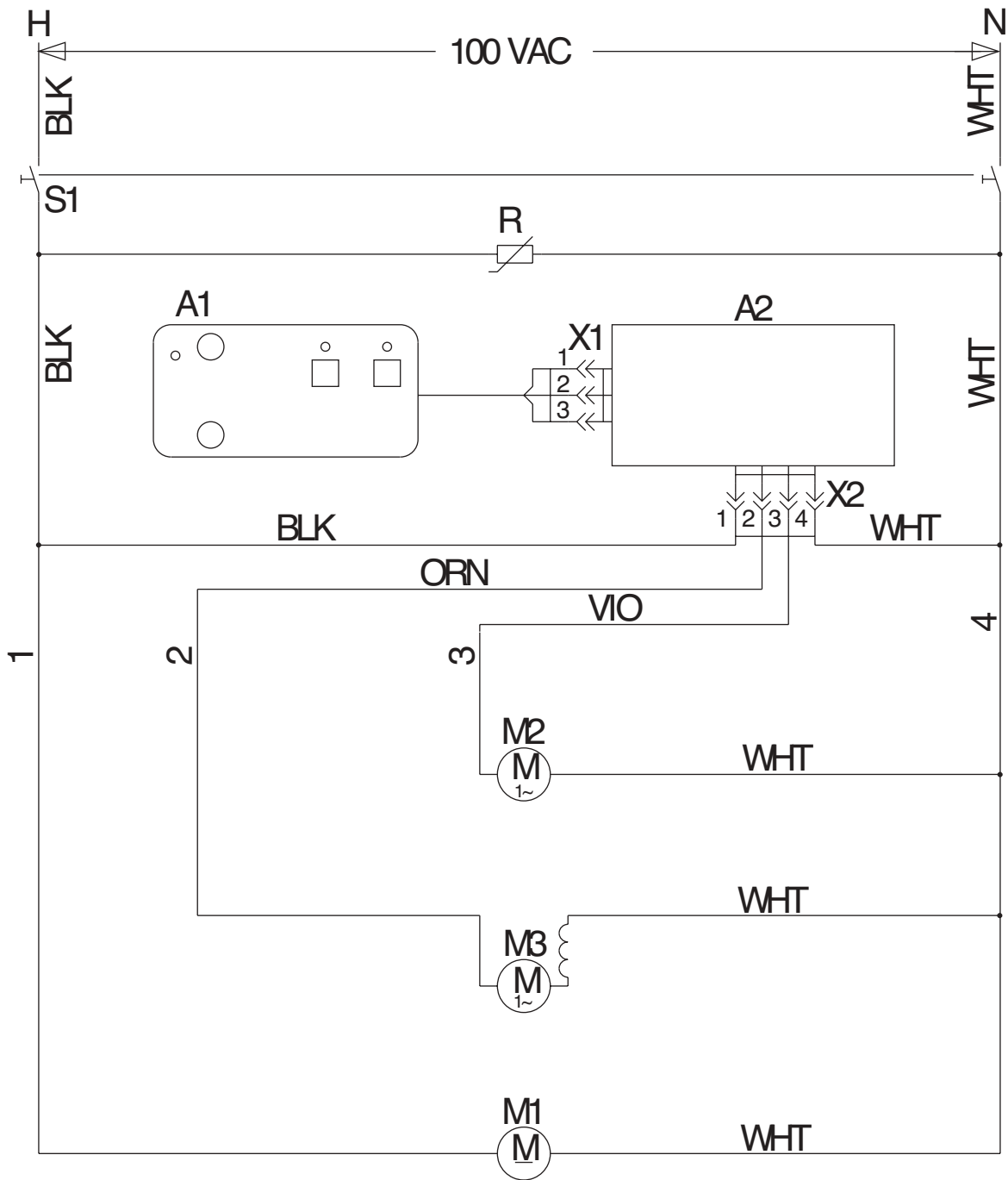

Item	Ref. No.	Qty	Description
A1	56264120	1	Membrane Switch Pad
A2	56264330	1	Controller PCB
M1	56264305	1	Solution Pump
M2	56264308	1	Brush Motor
M3	56250201	1	Vacuum Motor TSBUS2002-826
R	56264431	1	Varistor
S1	56393312	1	Main Switch
X1		1	Membrane Switch Pad
X2		1	Controller PCB Connector
>>1	56264022	1	Cord Assembly
>>2	56264270	1	Wire Assembly
>>3	56262006	1	Cord Assembly

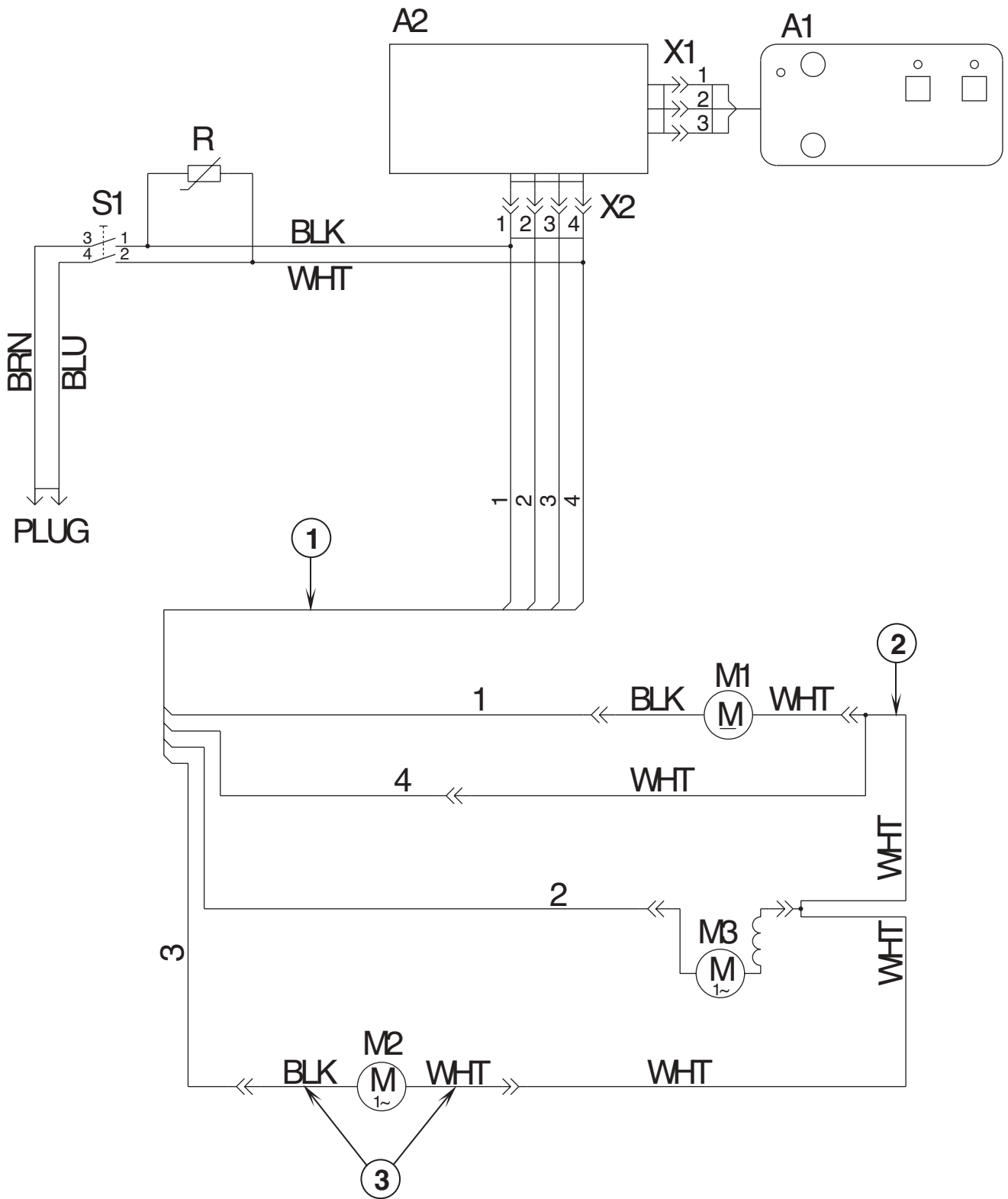

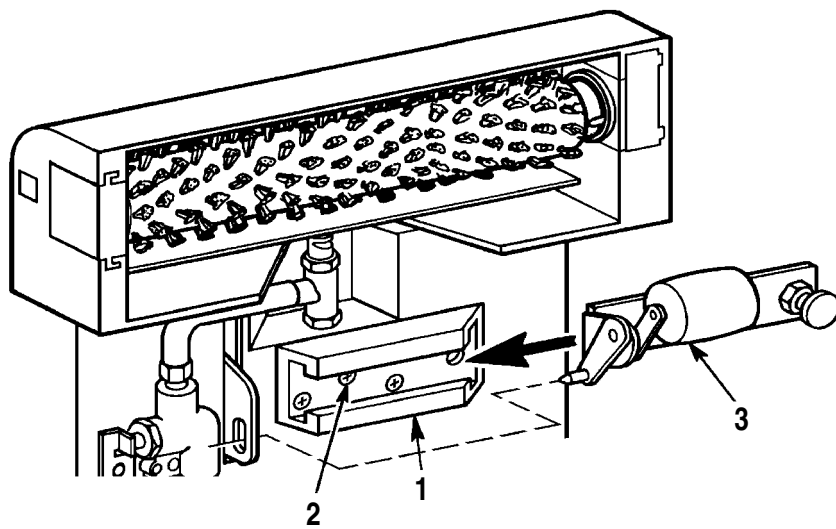
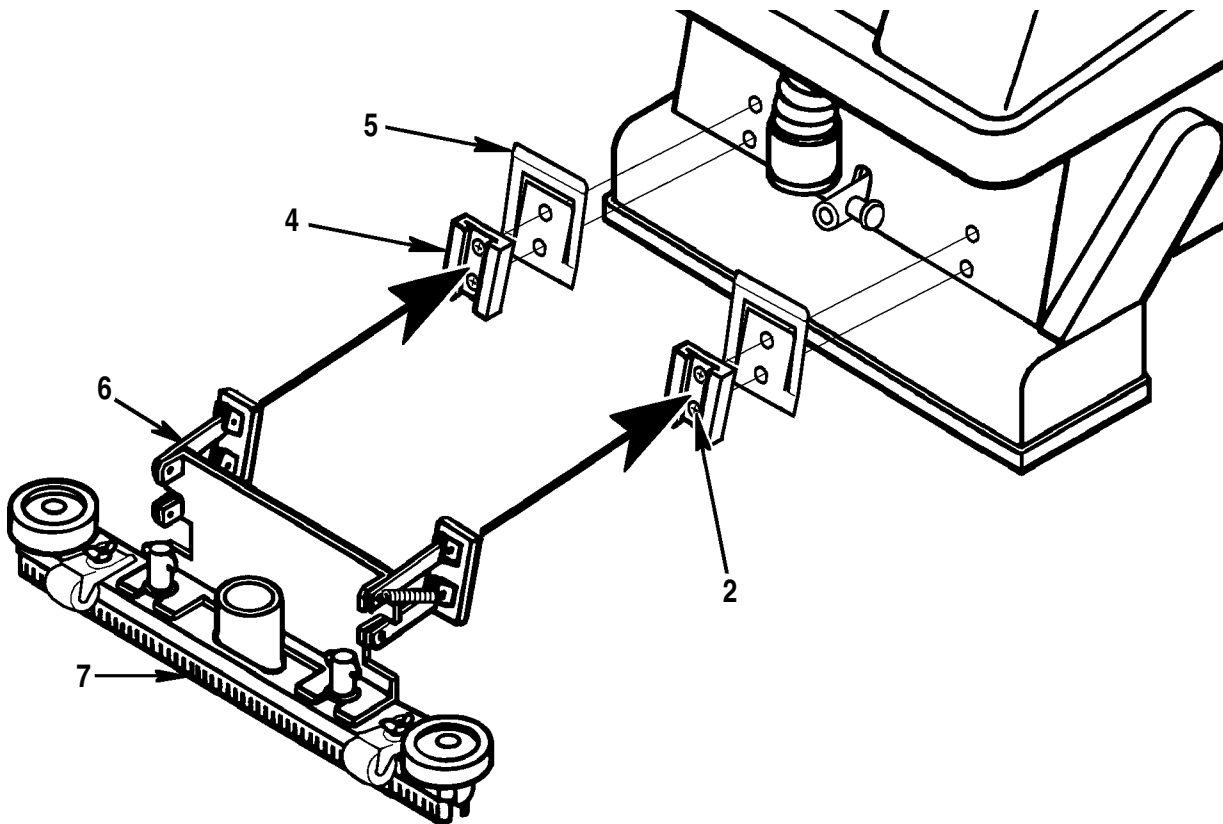

95-7	OPTIONAL HARD FLOOR KITS	BOOK C		
04-3	AX 300 / AX 400	C	1.3.1	25

Item	Ref. No.	Qty	Description
	56264369	1	Hard Floor Kit AX 300
	56262164	1	Hard Floor Kit AX 400
*	56040537	1	Instruction Sheet
1	56264183	1	Channel
2	56003096	7	Scr, Flt Phil 1/4-20 x .38
3	56264398	1	Carriage Assy
4	56264201	2	Channel
5	56264342	2	Clip
6	56264344	1	Squeegee Mount Assy (refer to page 27)
7	56264130	1	Squeegee Assy AX 300 (kit 56264369) (refer to page 29)
	56262165	1	Squeegee Assy AX 400 (kit 56262164) (refer to page 29)

* = Not Shown

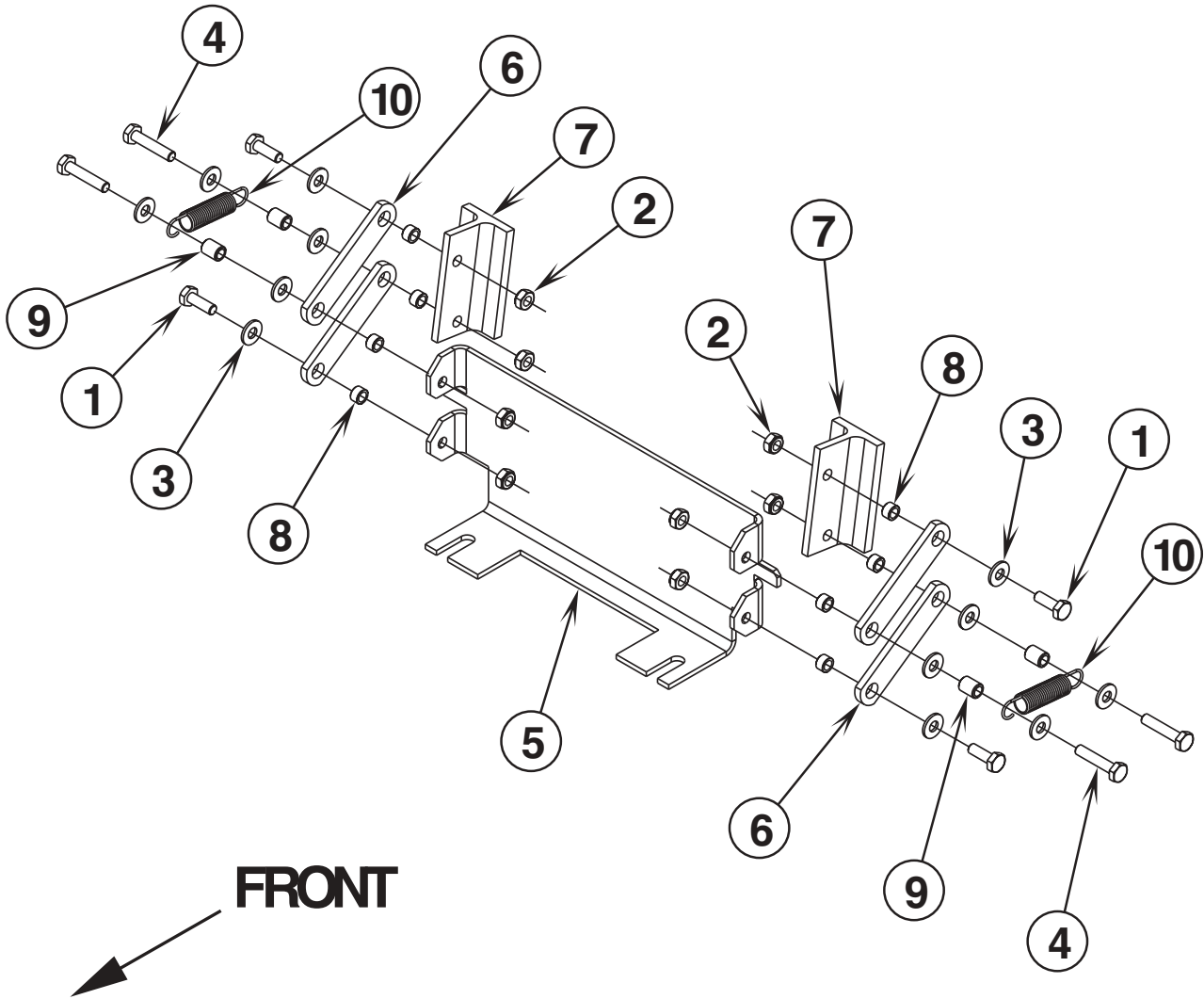

95-7	SQUEEGEE MOUNT ASSEMBLY	BOOK C		
01-7	AX 300 / AX 400	C	1.3.1	27

Item	Ref. No.	Qty	Description
	56264344	1	Squeegee Mount Assy (#1-10)
1	56002807	4	Scr, Hex Hd SS 1/4-20 x .75
2	56002850	8	Nut, Hex Nyl Loc-Thin SS 1/4-20
3	56002859	12	Wsh, Flt SAE SS 1/4
4	56002897	4	Scr, Hex Hd SS 1/4-20 x 1.25
5	56264125	1	Mount, Squeegee
6	56264204	4	Arm
7	56264273	2	Bracket
8	56379298	8	Bushing
9	56475411	4	Bushing
10	56481699	2	Spring

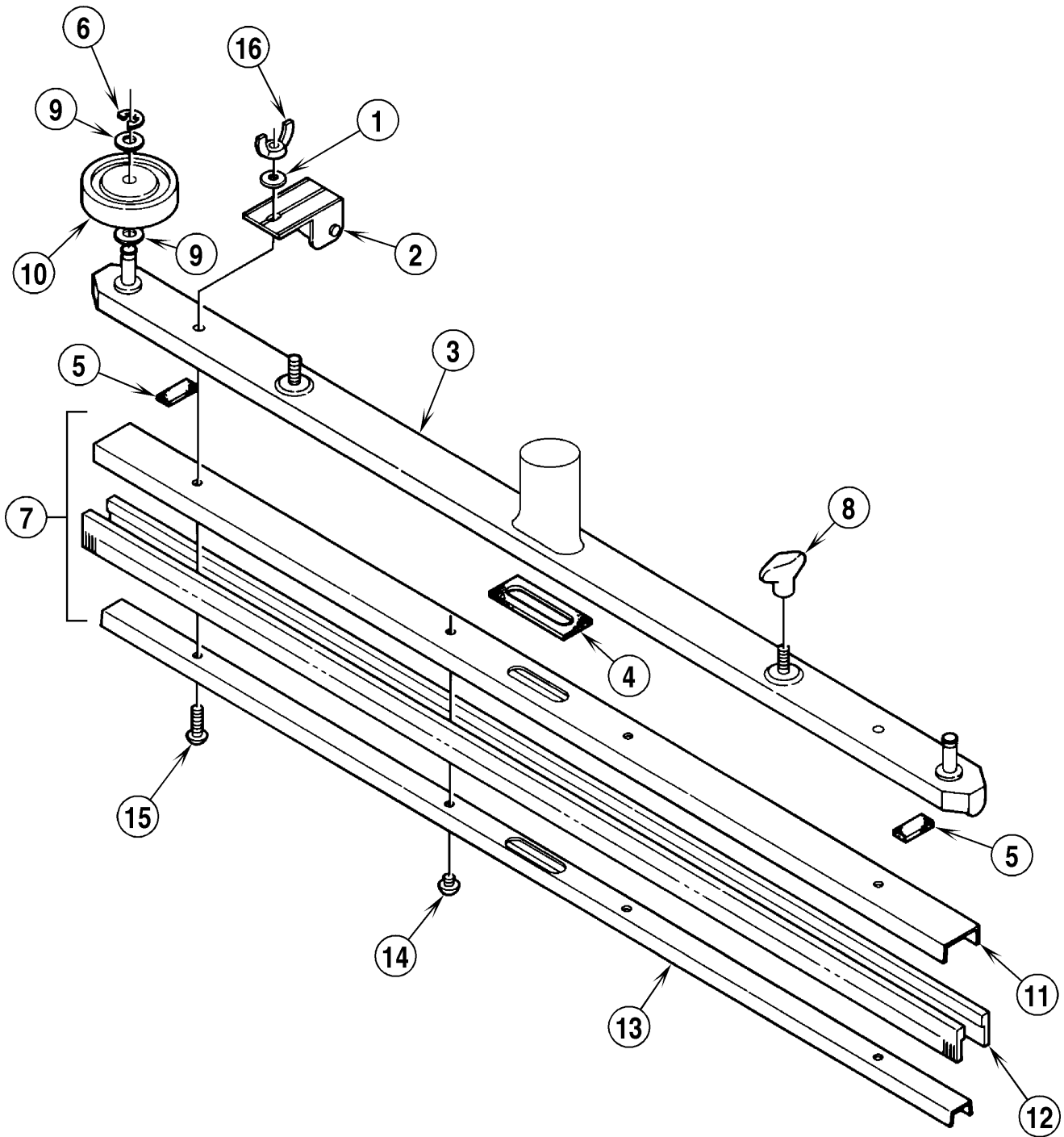

95-7	SQUEEGEE ASSEMBLY	BOOK C		
01-7	AX 300 / AX 400	C	1.3.1	29

Item	Ref. No.	Qty	Description
	56264130	1	Squeegee Assy AX 300 (#1-10)
	56262165	1	Squeegee Assy AX 400 (#1-10)
1	56002859	2	Wsh, Flt SAE SS 1/4
2	56387376	2	Roller Assy
3	56264158	1	Channel Weld't AX 300
	56262166	1	Channel Weld't AX 400
4	56400613	1	Gasket
5	56400614	2	Gasket
6	56003269	2	Ring, Ret Ext. Type E Reinf.
7	56264159	1	Squeegee Cartridge AX 300 (#11-16)
	56264172	1	Squeegee Cartridge AX 400 (#11-16)
8	56370711	2	Nut, Thumb
9	56009047	4	Wsh, Flt
10	56363855	2	Wheel
11	56264160	1	Channel AX 300
	56264166	1	Channel AX 400
12	56105577	2	Blade, Squeegee AX 300
	56105578	2	Blade, Squeegee AX 400
13	56264161	1	Retainer AX 300
	56264167	1	Retainer AX 400
14	56003037	2	Scr, Pan Phil SS 1/4-20 x .25
15	56003067	2	Scr, Pan Hd SS 1/4-20 x 1.00
16	56009048	2	Nut, Wing Loc 1/4-20

Optional Hard Floor Brushes

The AX 300 and 400 come standard with a carpet brush. Optional brushes for use on hard floors must be ordered separately. If you plan to clean hard floors, you should also order the Hard Floor Kit (see page 25) for your machine.

DESCRIPTION	AX 300	AX 400
Standard Carpet Brush (Black Bristles)	56264357	56264358
Optional Smooth Hard Floor (Blue Bristles)	56264360	56264363
Optional Light Grit Hard Floor (Gray 500)	56264361	56264364
Optional Grout Grit Hard Floor (Gray 240)	56264362	56264365
Optional MidLite Grit 180 Hard Floor	56264424	56264426

Optional Accessory Tools

The AX 300 and 400 can be fitted with optional attachments which must be ordered separately. To use these accessory tools, attach the accessory vacuum hose to the left tube on the recovery tank cover. Attach the accessory solution hose to the fitting on the right rear side of the machine. Connect the other end of the vacuum and solution hoses to the accessory tool. When using accessory tools, turn the brush motor switch OFF.

CARPET TOOLS	REF. NUMBER
4' Stainless Steel Drag Tool	56262029
Stainless Steel Hand Tool	56262028
Plastic Hand Tool	56800385
Plastic & Stainless Drag Tool	56800390
15' Scrub and Vac Hose	56249318

HARD FLOOR TOOLS	REF. NUMBER
4' Scrub and Vac Wand	56204197
14" Scrub and Vac Tool	56262013
20" Scrub and Vac Tool	56262014
15' Scrub and Vac Hose	56249318

95-7	BRUSH SELECTOR GUIDE	BOOK C		
01-1	AX 300 / AX 400	C	1.3.1	31

The versatile AX 300 and 400 power cleans carpets or hard-floor surfaces. They're compact and lightweight so they're portable and easy-to-maneuver in tight areas. The family of AX extractors are 30.5 and 38 cm cleaning widths.

New technology has made extraction the preferred method for interim/daily carpet or hard floor maintenance and restorative cleaning. The AX family of machines has the versatility you need when clean floors count. Now you can clean both carpet and hard floors with one easy-to-use machine. You can power scrub grouted and indented tile, smooth terrazzo or concrete . . . or any type of carpet.

	AX 300	AX 400
Nylon brush, blue, hard floor only	56264360	56264363
AgLite Grit 500 brush, hard floor only	56264361	56264364
MidGrit 240 brush, hard floor only	56264362	56264365
Standard nylon brush for carpets	56264357	56264358

For hard floor cleaning, the blue nylon brush is the least aggressive, Grit 500 is mildly aggressive, Grit 240 is more aggressive.

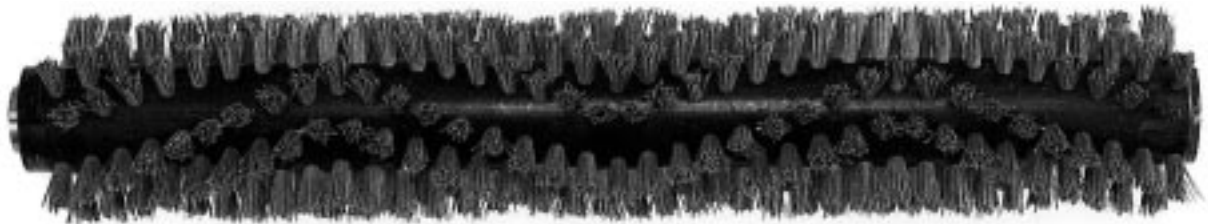

Austria (Sales Sub)

Nilfisk-Advance GmbH	Phone: +43
Voralberger Allee 46	1616 58 30 22
A-1230 Wien	Fax: +43
info@nilfisk-advance.at	1616 58 30 40
www.nilfisk-advance.at	

Belgium (Sales Sub)

Nilfisk-Advance NV/SA	Phone: +32
Doornveld Sphere Business Park	(0)2467 60 50
Industrie Asse 3, No. 11	Fax: +32
B-1731 Zellik-Asse	(0)2463 44 16
www.nilfisk-advance.be	

Czech Republic (Sales Sub)

Nilfisk-Advance s.r.o.	Phone: +420
Lysinská 44/1863	2 44 09 09 12
143 00 Praha - Modrany	+420
Czech Republic	2 44 09 09 21 4
	Fax: +420
	2 44 40 23 93

Denmark

Nilfisk-Advance A/S	Phone: +45
Sognevej 25	43 23 81 00
DK-2605 Brøndby	Fax: +45
mail@nilfisk-advance.dk	43 43 77 00
www.nilfisk-advance.com	

Denmark (Prod. Sub)

Gerni A/S	Phone: +45
Myntevej 2	89 12 22 00
DK-8900 Randers	Fax: +45
www.gerni.com	86 43 14 81

Denmark (Sales Sub)

Nilfisk-Advance Nordic A/S	Phone: +45
Sognevej 25A	43 23 40 50
Postbox 344	Fax: +45
DK-2605 Brøndby	43 23 40 60
kundeservice@nilfisk-advance.dk	
www.nilfisk-advance.dk	

France (Sales Sub)

Nilfisk-Advance S.A.	Phone: +33
27 avenue de la Baltique	1695 98 700
Villebon sur Yvette	Fax: +33
P.B. 246	1695 98 701
F-91944 Courtaboeuf Cedex	
info@nilfisk-advance.fr	
www.nilfisk-advance.fr	

Germany (Sales Sub)

Nilfisk-Advance AG	Phone: +49
Siemensstrasse 25-27	4101 3990
Postfach 1361	Fax: +49
D-25462 Rellingen	4101 39 91 91
info@nilfisk-advance.de	
www.nilfisk-advance.de	

Greece (Sales Sub)

Nilfisk-Advance A.E.	Tel.: +30
8, Thoukididou Str.	210 963 3443
Argioupoli	Fax: +30
Gr - 164 52 Athens	210 965 0975
Greece	

Holland (Sales Sub)

Nilfisk-Advance B.V.	Phone: +31
Camerastraat 9 (2e verdieping)	36 546 07 00
1322 BB Almere	Fax: +31
Postbus 60112	36 523 51 48
1320 AC Almere	
www.nilfisk-advance.nl	

Ireland (Sales Sub)

Nilfisk-Advance Limited	Phone: +35
28 Sandyford Office Park	3 12 94 38 38
Sandyford, Dublin 18	Fax: +35
Ireland	3 12 94 38 45

Italy (Prod & Sales Sub)

CFM SpA	Phone: +39
Nilfisk-Advance Div. Guardamiglio	0377 /414021
Localita Novella III	/45 1124
I-26862 Guardamiglio (Mi)	Fax: +39
	0377 51 443

Italy (Prod & Sales Sub)

CFM S.p.A.	Phone: +39
Via Porrettana 1991	059 973 0000
I-41059 Zocca (Modena)	Fax: +39
cfm@cfm.it	059 973 0099

Norway (Sales Sub)

Nilfisk-Advance AS	Phone: +47
Ulvenveien 89C	23 06 75 00
N-0581 Oslo	Fax: +47
	23 06 75 01

Poland (Sales Sub)

Nilfisk-Advance Sp.Z.O.O.	Phone: +48
05-800 Pruszków	22 738 37 50
ul. 3-go MAJA 8	Fax: +48
Poland	22 738 37 51

Portugal (Sales Sub)

Nilfisk-Advance, Lda.	Phone: +35
Sintra Business Park	121 911 2670
Zona Industrial Da Abrunheira	Fax: +35
Edificio 1, 1o A	121 911 2679
P-2710-089 Sintra	

Russia (Sales Sub)

Nilfisk-Advance LLC	Phone: 7
Vyatskaya str. 27, bld. 7	095 783 9602
127015 Moscow	Fax: +7
Russia	095 783 9603

Spain (Sales Sub)

Nilfisk-Advance S.A.	Phone: +34
Torre D'Ara	93 741 2400
Passeig del Rengle, 5 Pl.10	Fax: +34
E-08302 Mataró (Barcelona)	93 757 8020
nilfisk@nilfisk-advance.es	

Sweden (Sales Sub)

Nilfisk -Advance A/S	Phone: +46
Sjöbjörnsvägen 5	8555 94400
Box 44045	Fax: +46
S-100 73 Stockholm	8555 94430
info@nilfisk-advance.se	
www.nilfisk-advance.se	

Sweden (Prod.)

Nilfisk-Advance A/S	Phone: +46
Åmål Branch	5321 7500
Strömsbergsgatan	Fax: +46
Box 127	5321 7595
S-662 23 Åmål	

Switzerland (Sales Sub)

Nilfisk-Advance AG	Phone: +41
Ringsstrasse 19	71 92 38 444
Kirchberg/Industrie Stelzl	Fax: +41
CH-9500 Wil	71 92 35 283
www.nilfisk-advance.ch	

UK (Sales Sub)

Nilfisk-Advance Limited	Phone: +44
Newmarket Road	1284 763163
Bury St. Edmunds	Fax: +44
UK-Suffolk IP33 3SR	1284 750 562

USA (Prod.)

Nilfisk-Advance Inc.	Phone: +1 763
14600 21.st Avenue North	745 3500
Plymouth, MN 55447-3408	Fax: +1 763
www.mn.nilfisk-advance.com	745 3718

USA (Sales Sub)

Nilfisk-Advance America Inc.	Phone: +1 610
300 Technology Drive	647 6420
Malvern, PA 19355	Fax: +1 610
www.pa.nilfisk-advance.com	647 6427

Canada (Sales Sub)

Nilfisk-Advance Canada Comp.	Phone: +1 905
396 Watline Avenue	712 3260
Mississauga, Ontario L4Z 1X2	Fax: +1 905
	712 3255

Australia (Sales Sub)

Nilfisk-Advance Pty. Ltd.	Phone: +61(0)2
48 Egerton Street	9648 2700
Silverwater, NSW 2128	Fax: +61(0)2
Postal addresse:	9648 2711
PO Box 6046	
Silverwater. NSW 1811	
info@nilfisk-advance.com.au	
www.nilfisk-advance.com.au	

China (Shenzhen)

Nilfisk-Advance (Shenzhen) Ltd	Phone: +86 755
Blok 3, Unit 130, 1001 Honghua Road	8359 7937 el.
Int. Commercial & Trade Center	8359 7939-42
Fuitian Free Trade Zone	Fax: +86 755
518038 Shenzhen	8359 1063
P.R. China	

China (Suzhou)

Nilfisk-Advance Professional	Phone: +86 512
Cleaning Equipment (Suzhou) Co. Ltd.	8918 5656
306 Su Hong Zhong Road, Build. 2	Fax: +86 512
Suzhou Industrial Park	8918 5666
215021 Suzhou	
P.R. China	

Hong Kong (Sales Sub)

Nilfisk-Advance Ltd.	Phone: +852
2001 HK Worsted Mills Ind'l Bldg.,	2427 5951
31-39 Wo Tong Tsui St.	Fax: +852
Kwai Chung, Hong Kong	2487 5828

Japan (Sales Sub)

Nilfisk-Advance Inc.	Phone: +8145
3-17-40-101 Chigasaki Higashi	942 7741
Tsuzuki-ku, Yokohama 224-0033	Fax: +8145
Japan	942 6545

Malaysia (Sales Sub)

Nilfisk-Advance Sdn Bhd	Phone: +60 3
No. 21, Jalan SS 25/41	7956 8188
Mayang Industrial Park	Fax: +60 3
47301 Petaling Jaya	7966 6828
Selangor, Malaysia	

New Zealand (Sales Sub)

Nilfisk-Advance Limited	Phone: +64(0)9
Danish House	525 0092
6 Rockridge Avenue	Fax: +64(0)9
Penrose 92-829	525 6440
Auckland1135	
Postal addresse:	
Private Bag 92 825	
Auckland	
New Zealand	

Singapore (Sales Sub)

Nilfisk-Advance Pte. Ltd.	Phone: + 65
22,Woodlands Industrial Park E1	6 7599100
Singapore 757740	Fax: +65
sales@nilfisk-advance.com.sg	7599133

Taiwan, ROC (Sales Sub)

Nilfisk-Advance Ltd.	Phone: +886
Taiwan Branch (H.K.)	2 2239 8812
1F, No. 193, Sec.2	Fax: +886
Xing Long Rd., Taipei	2 2239 8832
Taiwan, R.O.C.	

Thailand (Sales Sub)

Nilfisk-Advance Co. Ltd.	Phone: +66 2
89 Soi Chokechai-Ruammitr	275-5630
Viphavadee-Rangsit Road	Fax: +66 2
Ladyao, Jatuchak, Bangkok 10900	691-4079
Thailand	



www.nilfisk-advance.com

© 2004 Printed in USA