

SINGER



**FEATHERWEIGHT
221K5**

THE SINGER MANUFACTURING COMPANY

Instructions for using

SINGER*
221K5

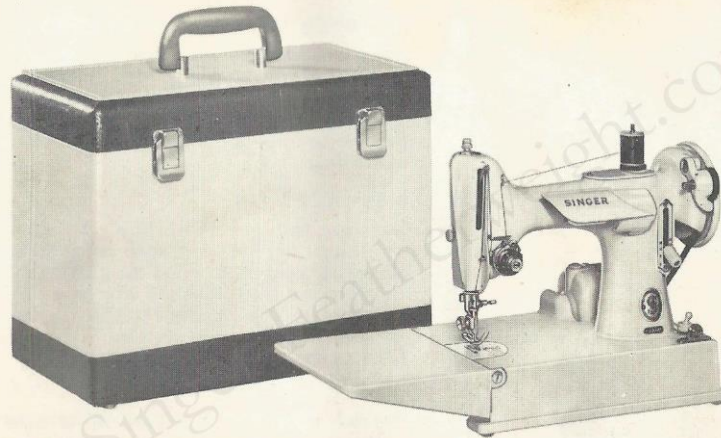

FEATHERWEIGHT*

Portable Electric Sewing Machine

2



AS THE OWNER OF THE SINGER 221K5

You have a machine with a tradition of superior craftsmanship—a tradition you will recognize in the smooth, efficient operation of this lightweight machine. Distinctive clothing for yourself and your family and numerous items for the home—can be yours at a fraction of their ready-made cost.

SINGER SERVICE

Wherever you go you will find expert, dependable SINGER* SERVICE close at hand. SINGER is interested in helping you keep your SINGER SEWING MACHINE in top running condition. That is why you should always call your SINGER SEWING CENTER if your machine ever requires adjustment or repair. Only from your SINGER SEWING CENTER can you obtain the services of a trained SINGER repair man and warranted SINGER* parts.



EVERYTHING FOR THE WOMAN WHO SEWS

The answer to your sewing needs is at your SINGER SEWING CENTER. There you will find a wide choice of sewing aids, notions, sewing information and services. Look for the famous red "S" and SINGER trademarks on your SINGER SEWING CENTER and the ever-ready SINGER SERVICE CAR. Look under SINGER SEWING MACHINE CO., in phone book, for address nearest you.

*A Trademark of THE SINGER MANUFACTURING COMPANY

Copyright Under International Copyright Union

PRINCIPAL PARTS OF MACHINE 221K5

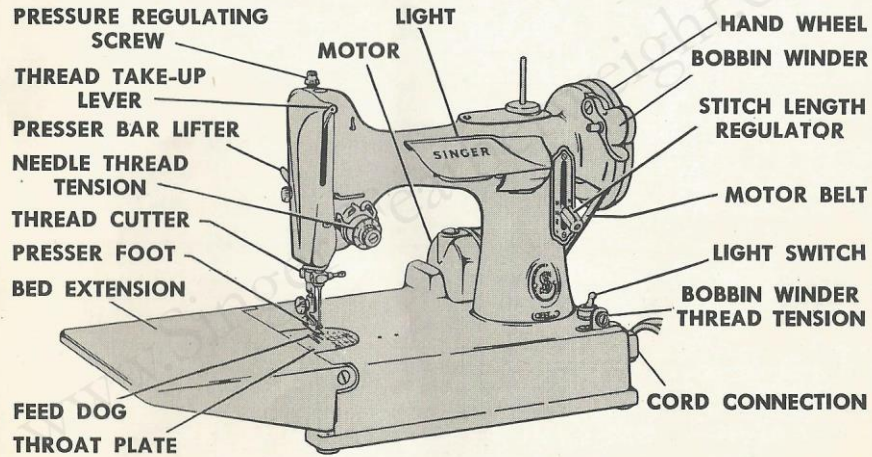

FABRIC, THREAD, NEEDLE AND STITCH LENGTH CHART

FABRICS	THREAD SIZES	NEEDLE SIZES	MACHINE STITCHES PER INCH
DELICATE —tulle, chiffon, fine lace, silk organdy, fine tricot	Fine Mercerized 100 to 150 Cotton Synthetic Thread	9	15 to 20
LIGHTWEIGHT —batiste, organdy, jersey, voile, taffeta, silk crepe, plastic film	50 Mercerized 80 to 100 Cotton A Silk Synthetic Thread	11	12 to 15 (8 to 10 for plastic)
MEDIUM WEIGHT —gingham, percale, pique, linen, chintz, faille, satin, fine corduroy, suitings	50 Mercerized 60 to 80 Cotton A Silk Synthetic Thread	14	12 to 15
MEDIUM HEAVY —gabardine, tweed, sailcloth, denim, coatings, drapery fabrics	Heavy Duty Merc. 40 to 60 Cotton	16	10 to 12
HEAVY —overcoatings, dungaree, upholstery fabrics, canvas	Heavy Duty Merc. 24 to 40 Cotton	18	8 to 10

NEEDLES AND THREAD

This machine uses needle
Catalog No. 2020 (15 x 1).
Sizes 9, 11, 14, 16 and 18.

For perfect stitching, choose needle and thread which correspond to the fabric according to the chart on page 4. Be sure to use like threads for both needle and bobbin.

NEEDLE INSERTION

- Raise needle bar to its highest point.
- Loosen needle clamp screw A.
- Insert needle (flat side to the left) up into needle clamp as far as it will go.
- Tighten clamp screw.

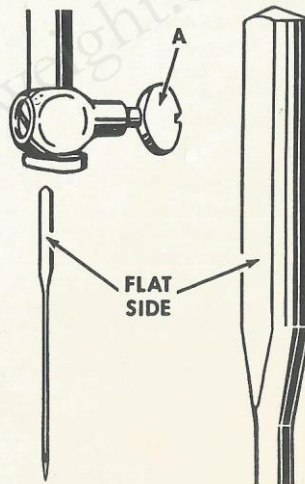

ELECTRICAL INFORMATION

The SINGER* Electric Motor at back of machine is furnished for operation on an alternating current of 110-120 volts, 25 to 75 cycles, or on 110-120 volts direct current. Special motors can be provided through your SINGER SEWING CENTER for direct or alternating current for any voltage between 50 and 145, and for 32 volts direct current.

Before Inserting Electric Plug be sure that voltage and number of cycles stamped on motor nameplate are within range marked on your electric meter installed by your power company.

Electrical Connection. Push 3-pin terminal plug on 3-pin terminal block at right of machine and connect plug at other end of cord to electrical outlet.

Speed Controller. The speed of machine is regulated by amount of pressure on foot controller.

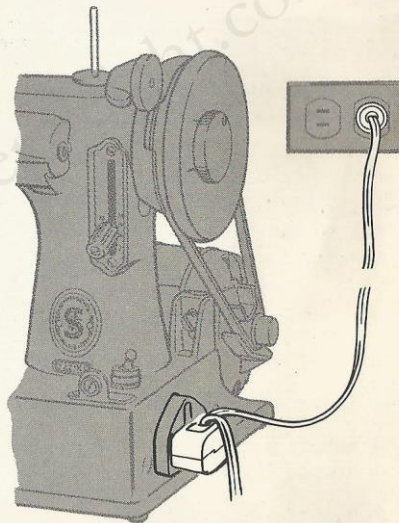

TO REMOVE BOBBIN CASE AND BOBBIN

Raise thread take-up lever to its highest position.

Raise bed extension.

Grasp bobbin case latch and withdraw bobbin case.

Release latch and bobbin will drop out.

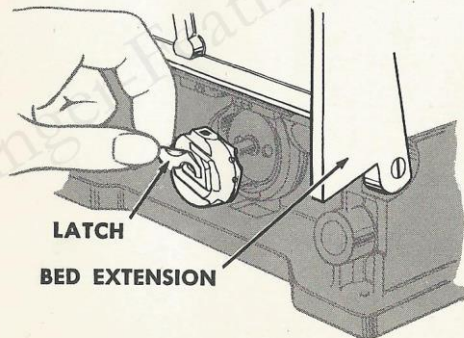

TO WIND BOBBIN

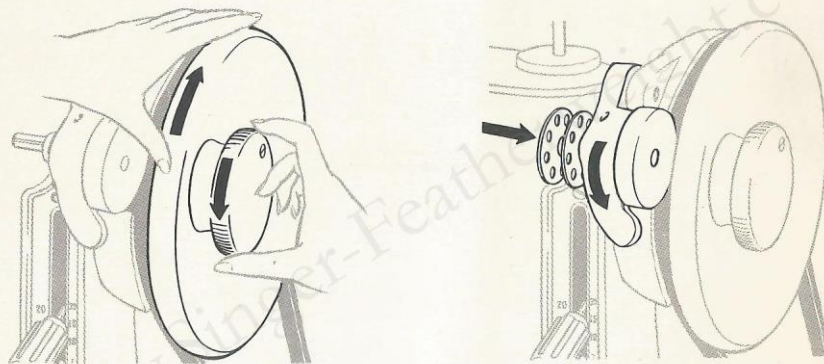

- Loosen stop motion screw with right hand.

- Place empty bobbin on spindle.
- Press bobbin winder down against belt.

TO WIND BOBBIN—Continued

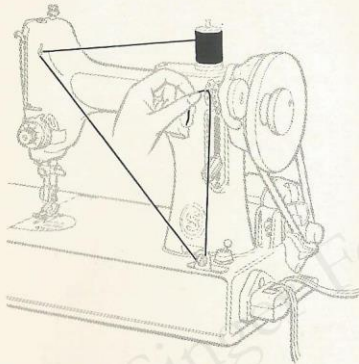

- Place spool of thread on spool pin.
- Thread machine as shown above.
- Hold end of thread and start machine. (End of thread will break off after a few coils have been wound on bobbin.)

If thread doesn't wind evenly on bobbin—

- Loosen screw which holds bobbin winder tension bracket to bed of machine.
- Move bracket to left if bobbin winds high on right.
- Move bracket to right if bobbin winds high on left.
- Tighten tension bracket screw.

When bobbin is full—

- Stop machine.
- Lift bobbin winder away from belt.
- Remove bobbin.
- Tighten stop motion screw.

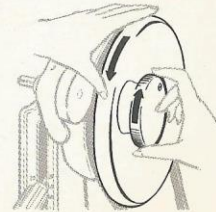

TO THREAD BOBBIN CASE

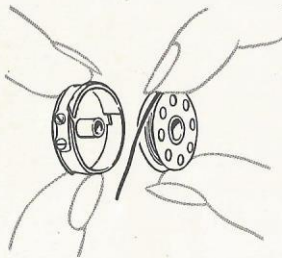

1. Hold bobbin case and bobbin so that thread leads off in direction shown above.

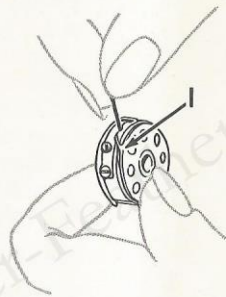

2. Place bobbin into bobbin case. Pull thread into slot 1.

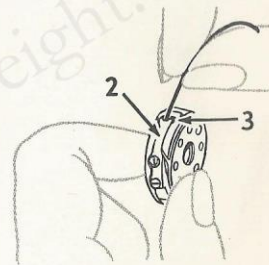

3. Pull thread under tension spring 2 and into slot 3 at end of spring, as shown.

TO REPLACE BOBBIN CASE

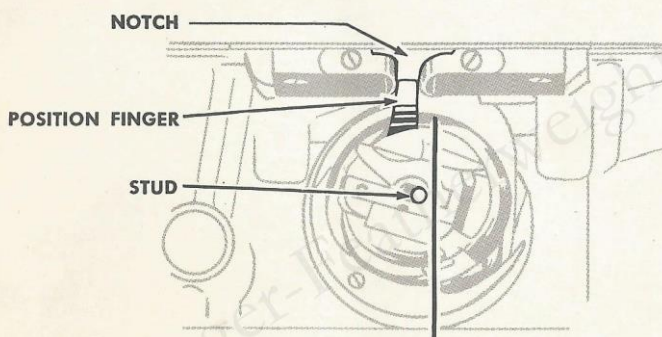

Hold bobbin case by latch and place it on stud, having thread draw from top of bobbin case.

Release latch and press bobbin case back until latch enters groove in stud. Allow about three inches of thread to hang free from bobbin case and turn down bed extension.

CAUTION: If throat plate is removed for cleaning stitch forming mechanism, etc., *make certain*, when replacing throat plate, that position finger of bobbin case base enters notch of position plate attached to underside of throat plate, as shown above.

UPPER THREADING

- Raise take-up lever to its highest point.
- Place spool of thread on spool pin.
- Lead thread through threading points shown.
- Thread needle from *right* to left.
- Draw sufficient thread through eye of needle with which to start sewing.

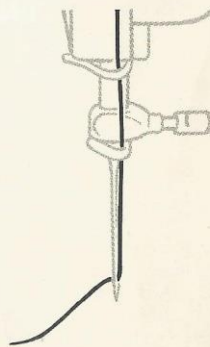
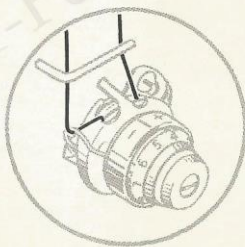
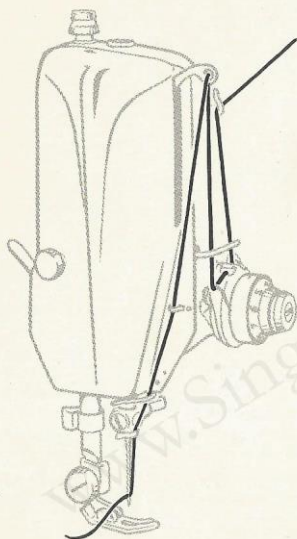

STITCH LENGTH REGULATOR

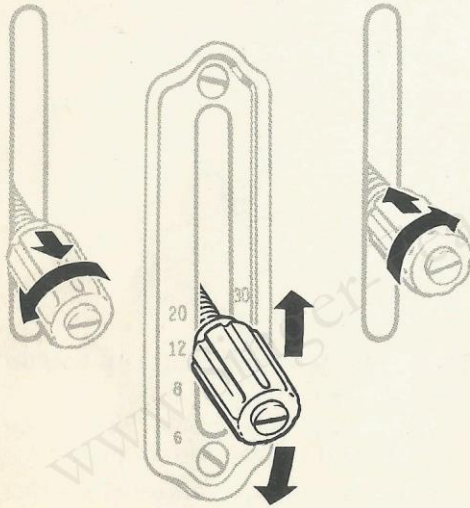

Numerals on the indicator plate represent approximate number of stitches per inch.

To set stitch length—

- Turn thumb nut to the left.
- Set lever at desired stitch setting.
- Turn thumb nut to the right until it rests against indicator plate.

Once the thumb nut has been tightened, reverse stitching is accomplished by raising the lever to its highest point.

PREPARING TO SEW

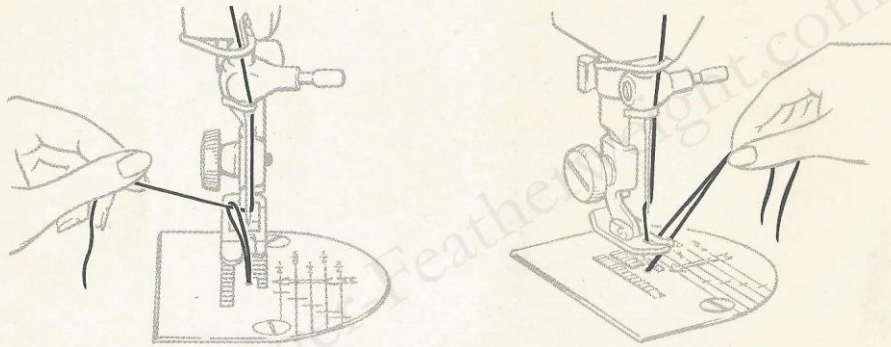

- Have take-up lever at its highest point.
- Hold needle thread lightly with left hand.
- Turn hand wheel so that needle

enters plate and brings up bobbin thread.

- Pull end of bobbin thread up through needle hole in plate.
- Lay both threads diagonally under presser foot.

SEWING A SEAM

- Set stitch regulator for desired stitch length.
- Position needle in fabric about $\frac{1}{2}$ inch from edge.
- Raise stitch regulator to reverse.
- Lower presser foot.

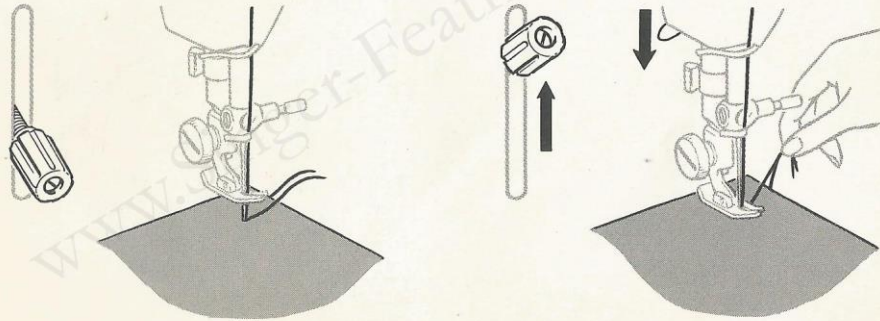

SEWING A SEAM—Continued

- Back stitch to edge of fabric for reinforcement.
- Lower stitch regulator for forward stitching of seam.

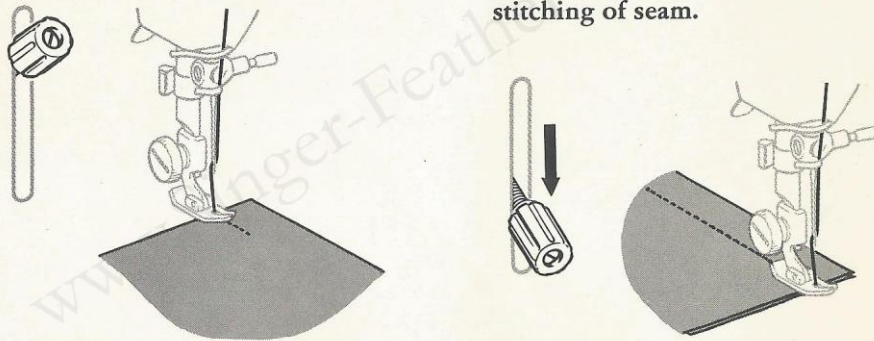

SEWING A SEAM—Continued

- Raise stitch regulator and back stitch to reinforce end of seam.

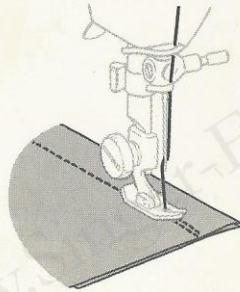

- With take-up lever at its highest point, raise presser foot, draw fabric back and cut threads on thread cutter.

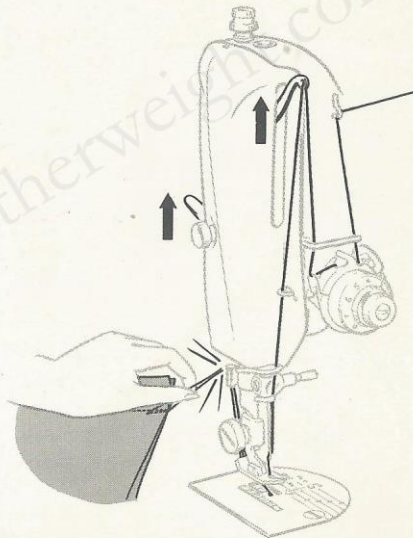

GUIDING AND SUPPORTING FABRICS

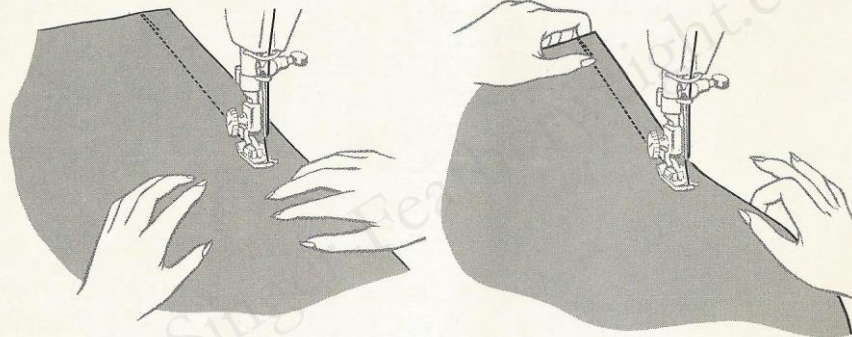

Most fabrics need to be guided only in front of the presser foot.

Fabrics of unusual texture and weave, filmy sheers, crepes, knits, tricots, etc., require support while being stitched.

For such fabrics apply gentle tension on the seam by holding fabric in front and in back of the presser foot.

PRESSURE ADJUSTMENTS

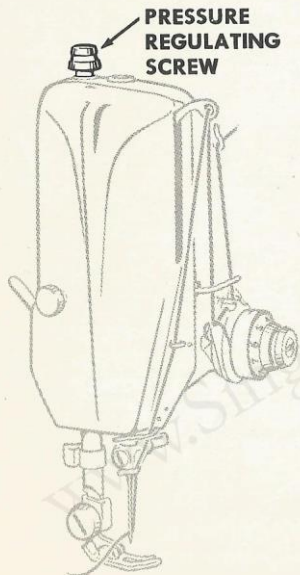

- To decrease pressure, turn thumb screw up.



- To increase pressure, turn thumb screw down.

Pressure is the force the presser foot exerts on the fabric.

Too light a pressure will cause irregular feeding, which affects both quality of stitch and evenness of seams.

Too heavy a pressure not only affects stitch and seam quality, but will mar smooth surfaces and pile fabrics.

Surface finish, as well as weight and texture of the fabric, must be considered when determining the amount of pressure needed.

NEEDLE THREAD TENSION

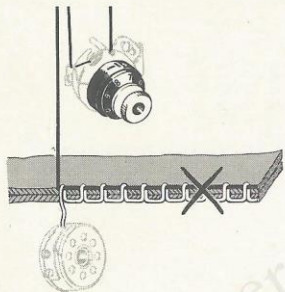

Needle thread tension too tight—correct by setting dial to lower number.

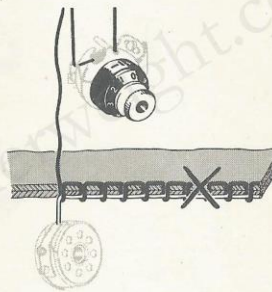

Needle thread tension too loose—correct by setting dial to higher number.



A perfectly locked stitch results with upper and lower tensions balanced so that needle and bobbin threads are drawn equally into fabric.

BOBBIN THREAD TENSION

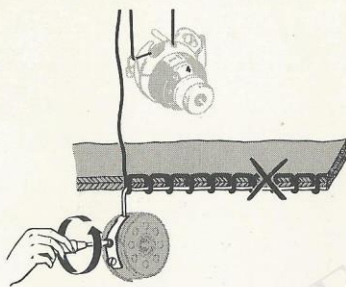

Bobbin thread tension too tight—correct by turning screw counterclockwise.

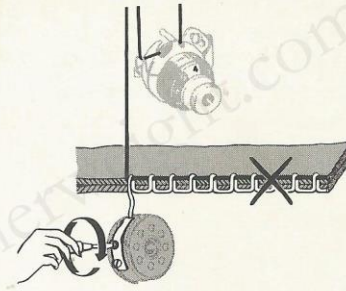

Bobbin thread tension too loose—correct by turning screw clockwise.



A perfectly locked stitch results with upper and lower tensions balanced so that needle and bobbin threads are drawn equally into fabric.

DARNING

Worn or torn areas on household textiles and clothing can be darned effortlessly and quickly with little practice. Adjust Stitch Length Regulator for desired stitch length and decrease pressure by turning thumb screw up (see page 19). The pressure should be lighter than for normal sewing but not too light to prevent work from feeding smoothly.

Place portion to be darned under the presser foot. Lower presser bar and start stitching, alternately allowing fabric to feed normally away from you and then gently pulling fabric toward you. Continue this forward and backward motion until area

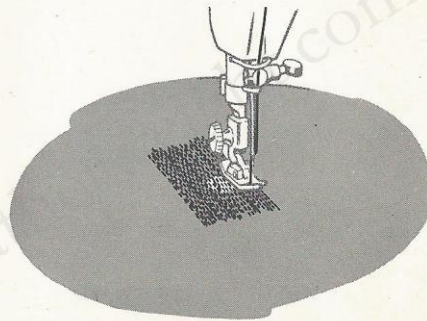

to be darned is filled with parallel lines of stitching. For reinforcement or additional strength, cover area with cross-side lines of stitching. Open areas require an underlay. Baste underlay in place before darning.

INSTRUCTIONS FOR USING ATTACHMENTS

**FOOT
HEMMER**
Page 24



SEAM GUIDE
Page 27



BINDER
Page 28

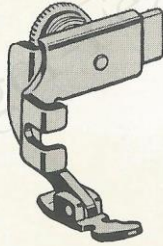

ZIPPER FOOT
Page 31

RUFFLER
Page 35

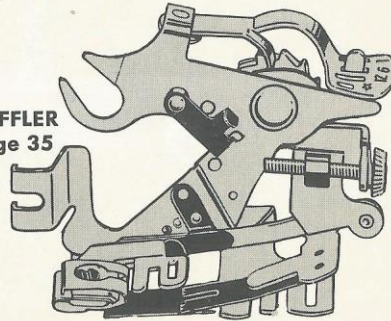

THE FOOT HEMMER



The foot hemmer forms and stitches a perfectly turned hem without basting or pressing. It is attached to the machine in place of the presser foot.

Applications

Fine hems	Hemming with lace
Edging ruffles	Lace insertion
Hemmed seams	Lingerie finishes

Hemming

- Form a double $\frac{1}{8}$ " fold at the very edge of the fabric.
- Crease this fold for about 2".
- Draw the needle and bobbin threads under the hemmer.

- Place the creased hem edge under the foot and take several stitches through the fold.
- Grasp the thread ends and the single fold in front of the hemmer and lift the single fold into the hemmer scroll.

Soft fabrics will enter the scroll best with the foot down, firm crisp fabrics with the foot raised.

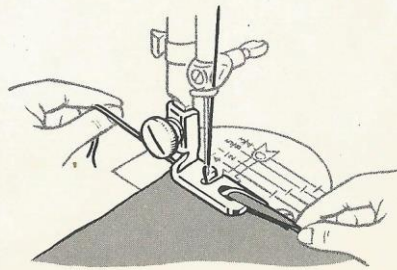

FOOT HEMMER (Cont'd)

- Stitch slowly for several inches until hem is well started. Hold thread ends in back of foot with the left hand and guide the raw fabric edge into the mouth of the scroll with the right hand.

Even feeding is essential to good hemming. The same width of fabric must be kept in the scroll of the hemmer at all times.

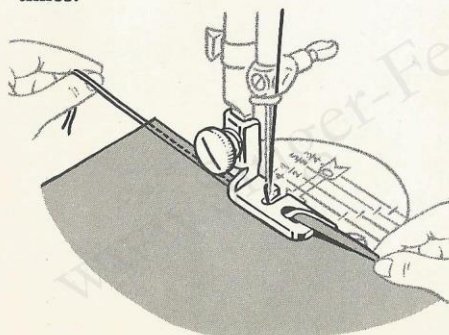
**Hemmed Seams**

Hemmed seams are often substituted for French seams where a fine narrow seam is appropriate.

- Allow a scant $\frac{1}{4}$ " seam allowance.
- With right sides of the fabric together, place the upper layer a scant $\frac{1}{8}$ " to the left of the lower layer.
- Insert the two fabric edges into the hemmer and proceed as for a plain hem.

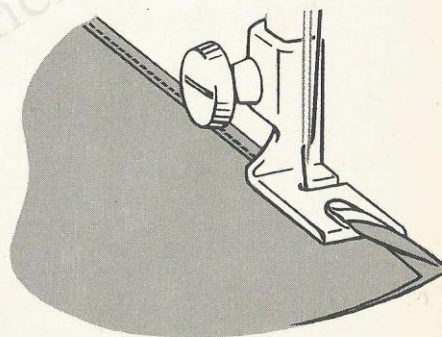
**FOOT HEMMER (Cont'd)****Hemming With Lace**

Lace edgings can be applied with the Foot Hemmer to trim lingerie hems, children's clothes, etc.

Lace Applied Over Hem

- Fold and start hem in usual way.
- Starting about 1 inch down from end of lace, place selvage under the needle, then lower the needle to hold lace firmly.
- Raise hemmer foot slightly and slip lace under back part of foot.
- Stitch slowly, guiding fabric with right hand and lace with left hand. Take care not to stretch the lace.

Lace Applied Under Hem

When using lace underneath the fold of a hem, the procedure is the same as when making a hemmed seam (page 25). Slip the lace in from the left as you would the second piece of fabric.

This method is used where a neat finish is desired on both sides of the material.

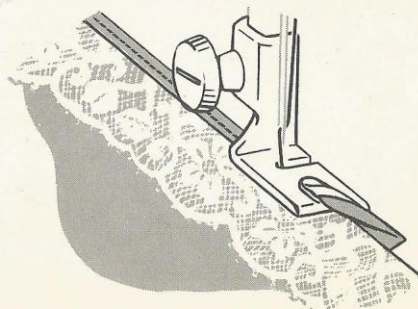
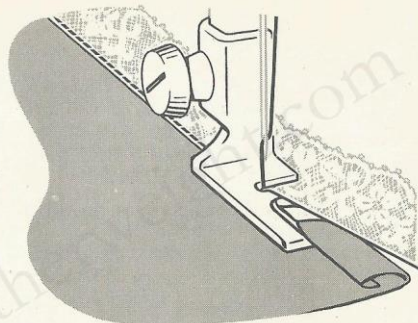

THE SEAM GUIDE

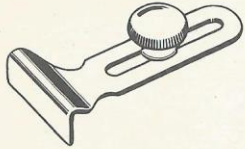

The seam guide is adjustable for spacing stitching at any distance between $\frac{1}{8}$ " and $1\frac{3}{8}$ " from a fabric edge.

Applications

Seams Stay stitching
Top stitching—single and multiple rows

- Attach the guide to the machine with the thumb screw in either of the threaded holes at the right of the needle.
- Adjust for width desired.
- For straight edges, align guide with the presser foot.
- For curved edges, set the guide at an angle so that the end closest to the needle acts as a guide.
- For pinned seams, place the pins with the points toward the seam edge so that they nip into the fabric at the stitching line. The hinged foot will then ride freely over the points.

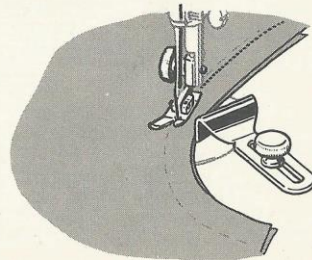
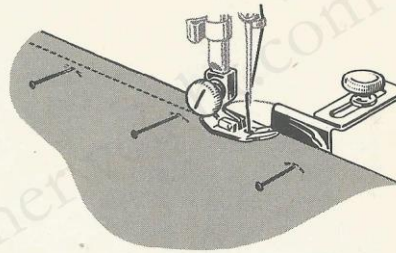

THE BINDER

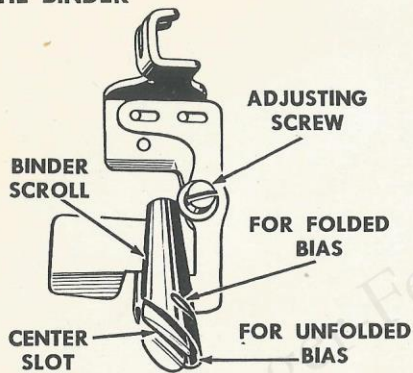

The binder is used to apply commercial binding as well as self-fabric bias to an unfinished edge.

This colorful trim is attractive when applied to children's wear, aprons and household textiles. It is a practical finish for seam edges that ravel and for making bound seams.

Inserting the Binding

Pre-folded commercial bias tape is inserted from the right into slot of the binder scroll.

- Cut the binding diagonally to form a long point.
- Insert pointed end into slot and pull through scroll.

Self-fabric binding should be cut $\frac{1}{4}$ " wide on the true bias.

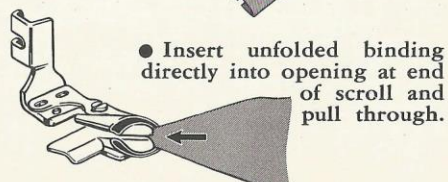

As binding passes through scroll raw edges are turned in.

BINDER—(Cont'd)**Adjustment and Operation of the Binder**

The edge to be bound is guided into center of scroll. Stitching is positioned close to edge of binding by adjusting scroll portion of attachment.

- Loosen adjusting screw. Move

scroll to the right or left as necessary.

Be sure that screw is well tightened after making an adjustment.

Never pull binding as it feeds through scroll. Allow attachment to do the work. Merely guide edge to be bound well into center of scroll as you stitch.

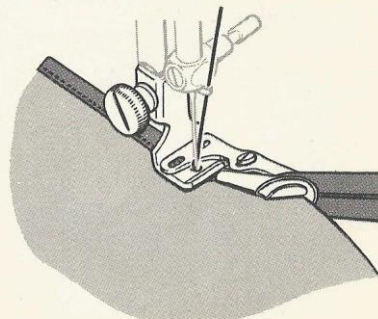
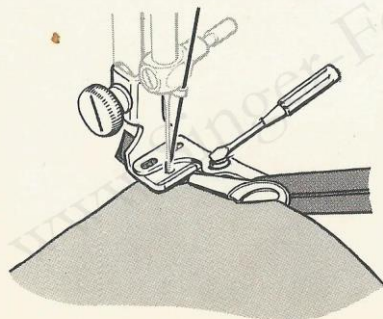
**BINDER (Cont'd)****Binding Curved Edges**

Curved edges can be bound as easily as straight edges, but require slightly different fabric handling.

Inside Curves

Inside curves are straightened as they are fed into the binder. If the fabric is soft and has a tendency to stretch, reinforce the edge with a

single row of stitching before binding.

Outside Curves

Outside curves tend to lead away from the center slot of the scroll and should be guided so that a full seam width is taken at the needle point. Do not attempt to pull or straighten the fabric into the full length of the scroll.

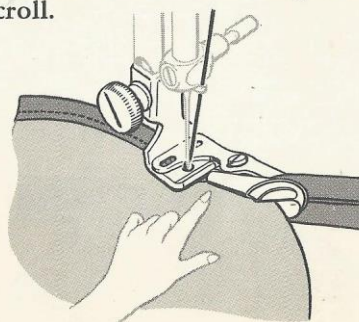
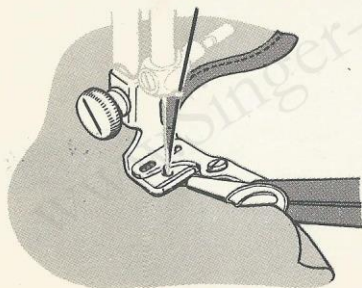

THE ZIPPER FOOT

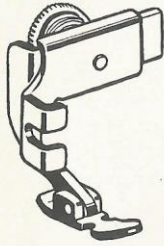

The zipper foot is designed for accurate placement of stitches close to a raised edge. The hinged feature of this foot insures even feeding over pins, heavy layers of fabric or cross seams. It is attached to the machine in place of the presser foot, and may be adjusted to either side of the needle.

Applications

Zipper insertions
Corded seams

Tubular cording
Slip cover welting

Preparation

- Attach zipper foot to machine in place of presser foot.
- Loosen zipper foot thumb screw and adjust foot to right or left of needle, as desired.
- Align the notch in the toe with the needle hole in the throat plate.
- Check adjustment by lowering needle into side notch, making sure it clears the foot.
- Lock foot in position by tightening thumb screw.

THE ZIPPER FOOT (Cont'd)

Zipper Insertion

Many different types of zippers are available for everything you sew. There are several satisfactory methods for insertion. Detailed sewing instructions are included in zipper packaging. For any method used, the Zipper Foot enables you to form an even line of stitching close to the zipper.

When the zipper is to the right of the needle—

- Adjust the Zipper Foot to the left of the needle.

When the zipper is to the left of the needle—

- Adjust the Zipper Foot to the right of the needle.

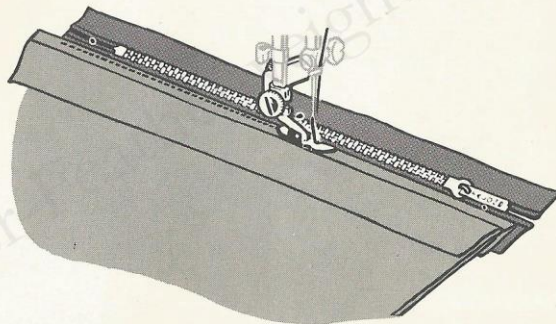

THE ZIPPER FOOT (Cont'd)

Corded Welting

Cable cord comes in a variety of sizes and when covered with a firmly woven fabric makes a welting that is an excellent seam finish.

This welting is prepared in advance and then stitched into the seam. Cut a true bias strip $1\frac{1}{4}$ inches wide, plus three times the width of the cord of either self or contrasting fabric. Sew strips together on the lengthwise grain to obtain desired length.

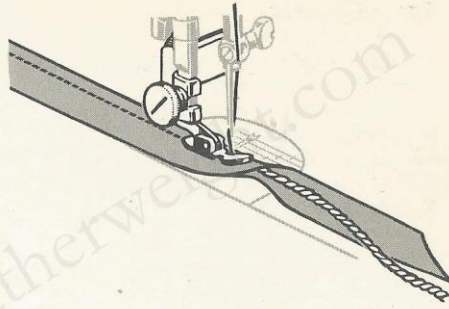
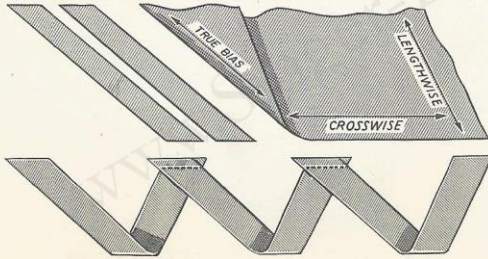

- Adjust zipper foot to left side of needle.
- Encase cord in bias strip, raw edges even.
- Lower presser bar.
- Stitch close to cord, using a stitch length slightly longer than for regular seaming.
- Do not crowd stitching against cord.

Corded Seams

The corded seam is a typical treatment for slip covers, children's clothes, blouses and lingerie.

When cording a seam the zipper foot is usually adjusted to the right of the needle so that the bulk of the work will fall to the left.

- Attach corded welting to right side of a single seam edge, using same stitch length as used for welting (page 33). Guide edge of foot next to cord, but **do not crowd**.
- Place attached corded welting over

second seam edge, and pin or baste together.

- Keep the first stitching uppermost as a guide and position the seam under the needle.
- Stitch, this time crowding the foot against the cord.

This method produces evenly joined seam edges and tightly set welting.

Curved seams are corded as easily as straight seams, except that a shorter stitch is used. Since the seam allowance of the welting is bias, it is easy to shape it to the seam.

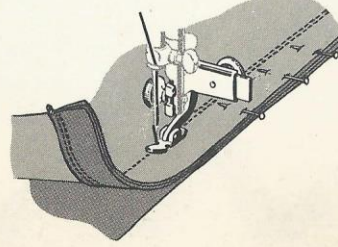
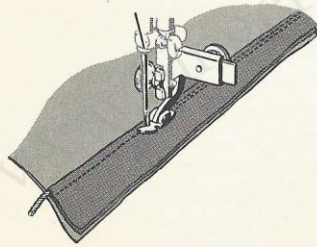

THE RUFFLER

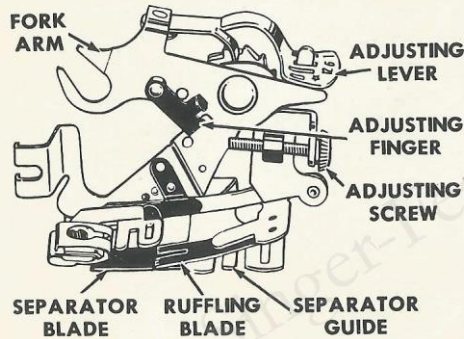

This attachment offers a simple and effective way to make gathered and pleated ruffles. Ruffles may be made separately or made and applied at the same time.

Adjusting Points

1. **Adjusting lever** sets ruffler for gathers or pleats. Number 1 space setting is for gathers and places fullness at every stitch. Numbers 6 and 12 are space settings for pleats, spacing them 6 or 12 stitches apart. Star is for plain stitching and is used when grouping gathers or pleats.

2. **Adjusting finger** is used only for pleating and affects width of pleat. It is disengaged by bringing it out of contact with adjusting screw.

3. **Adjusting screw** regulates fullness of gathers or pleats. When turned in to its limit with adjusting finger in place, attachment is set for its deepest pleat. When turned outward to its limit, with adjusting finger out of action, ruffler gives only a hint of fullness.

THE RUFFLER (Cont'd)

Activating Parts. Ruffling blade and separator blade are of blue steel and hold material to be gathered between them. Ruffling blade forms gathers or pleats by carrying fabric to needle according to spacing and fullness to which ruffler is adjusted. Separator guide is slotted to guide seam edges evenly and to separate ruffled strip from material to which ruffle is attached.

Preparation

- Raise needle to highest point.
- Locate ruffler on presser bar with fork arm over needle clamp screw. Securely tighten both presser bar and needle clamp screws.

Gathering

- Set adjusting lever on Number 1 setting and throw adjusting finger out of action.
- Turn adjusting screw for amount of fullness desired and set stitch length to space fullness. Turn screw in for more fullness; turn out for less fullness.

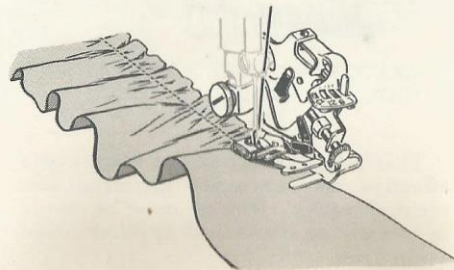

THE RUFFLER (Cont'd)

Attaching ruffle

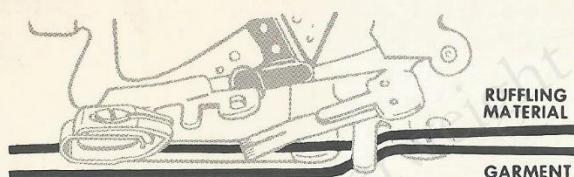

- Place ruffle strip between two blue blades and through first separator guide.
- Place material to which ruffle is to be attached between separator blade and feed of machine.
- Proceed as for plain gathering.

Right sides of fabrics are placed together when the seam is to fall to the inside.

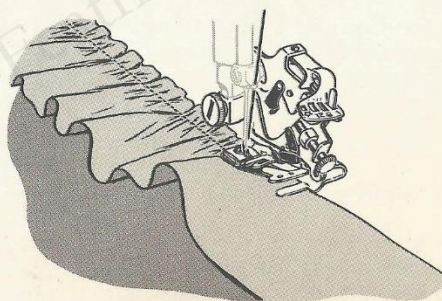

THE RUFFLER (Cont'd)

Length of sewing machine stitch also affects ruffle fullness. Since a given attachment setting puts an equal amount of fullness into each stitch regardless of its length, shortening the stitch (more stitches to inch) makes ruffle fuller; lengthening the stitch (fewer stitches to inch) makes it less full. For fine, closely spaced gathering, use a short stitch and an outward adjustment of adjusting screw. For deeper, less closely spaced gathering, turn adjusting screw inward and use a medium length stitch.

- Insert material to be gathered between blue blades and through first separator guide.



- Draw to back of needle.
- Lower presser bar and stitch.

Fabric texture influences performance of ruffler as well as results. Soft fabrics, cut on crosswise grain, are best adapted for gathering ruffles. Always test stitch length and ruffler setting on a scrap of self-fabric before proceeding with the actual work.

THE RUFFLER (Cont'd)

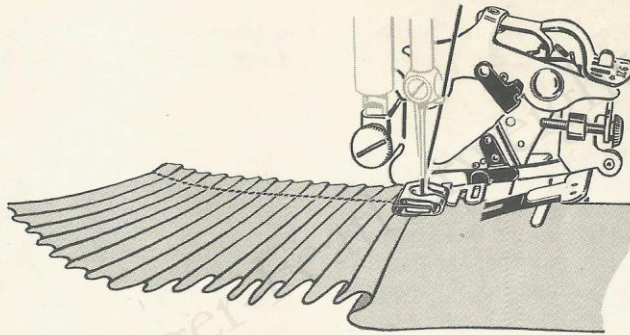
Pleating

- Move adjusting lever of ruffler to desired space setting for pleats either 6 or 12 stitches apart.
- Set stitch length.
For deepest pleat, activate adjusting finger and turn adjusting screw inward to its maximum setting. For smaller pleats turn adjusting screw outward.

A short stitch places pleats more closely together; a long stitch separates the pleats for a greater distance.

- Insert fabric to be pleated between blue blades and into first separator guide.
- Lower presser bar and stitch.

THE RUFFLER (Cont'd)

Crisp fabrics cut on the crosswise grain form the sharpest pleats. Glazed fabrics handle best if the glazed side is downward and the soft backing is next to the ruffler blade.

Group Pleating

By using star setting (plain stitching) alternately with 6 or 12 stitch setting, pleats are formed in groups. Even spacing between groups is accomplished by counting the number of stitches.

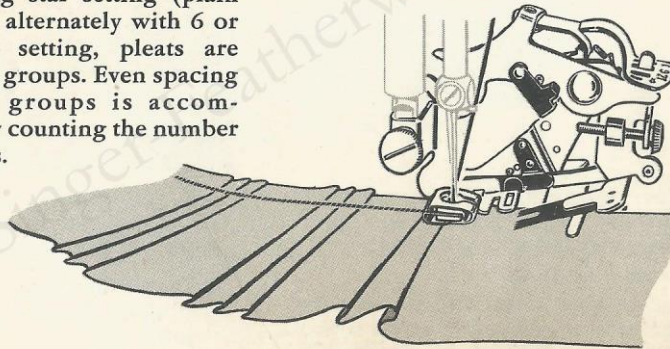

FASHION* AIDS

AVAILABLE FOR SEPARATE PURCHASE AT YOUR LOCAL
SINGER SEWING CENTER

**AUTOMATIC
ZIGZAGGER**

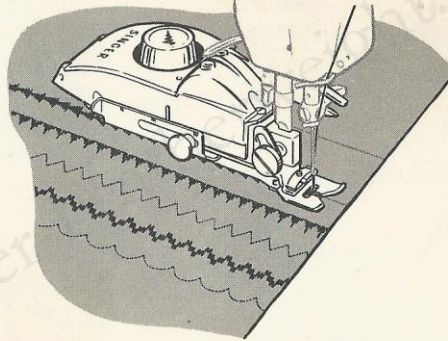

Decorative stitch patterns for border designs, lace applications and applique are accomplished automatically with the SINGER* Zigzagger.

This time-saving attachment will also blindstitch hems, mend rips and tears, reinforce seams, overedge seam edges and stitch scallop edges easily and quickly.

FASHION AIDS (Cont'd)

BUTTONHOLER

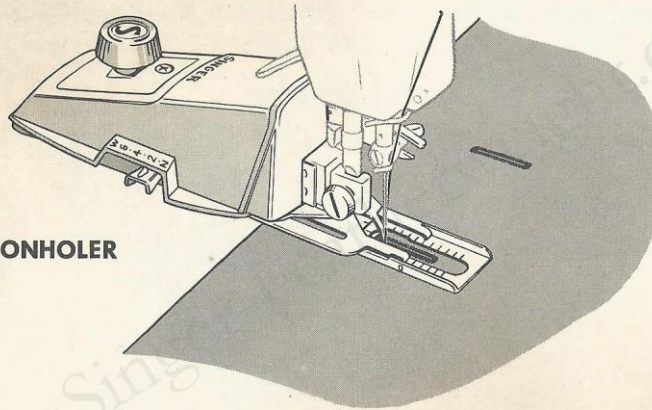

Beautiful, evenly stitched buttonholes are quickly and easily made with the SINGER* Buttonholer.

The attachment makes both straight and eyelet-end styles, auto-

matically guiding them to the size and shape selected.

Nine different lengths, ranging from $\frac{5}{16}$ " to $1\frac{1}{16}$ ", are available.

FASHION AIDS (Cont'd.)

THE EDGE STITCHER

This attachment provides a series of slotted guides which regulate the placement of stitching in relation to a fabric edge.

Among its many decorative and practical applications are the joining and insertion of lace, tucking from pin width to $\frac{1}{4}$ ", French seaming, seam piping, facing and seam finishing.



THE GATHERING FOOT

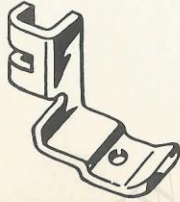

Single or multiple rows of shirring can be quickly and expertly placed with the gathering foot. Evenly spaced shirring is insured as this foot is designed to lock fullness into every stitch.

Applications

Plain shirring Waffle shirring
Elastic shirring Machine smocking

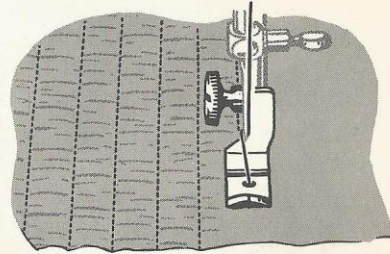

FASHION AIDS (Cont'd)

TUCKER

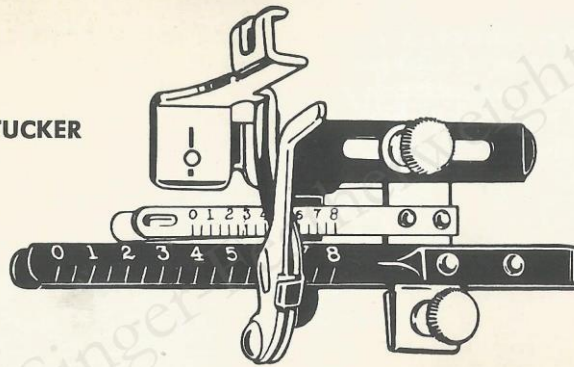

Since the beauty of tucking lies in its explicit accuracy, use of the Tucker will contribute greatly to the attractiveness of the work.

With this time-saving attachment, tucks up to one inch may be stitched and marked in one operation.

Two adjustable scales are provided to gauge tuck width and spacing.

TO CLEAN THE MACHINE

When in regular use—

The machine should be cleaned periodically to remove the lint and fluff which may have accumulated around the working parts.

To remove face plate, turn hand wheel until take-up lever reaches its highest point, then remove face plate thumb screw, raise face plate and carefully pass it toward you over end of take-up lever. Clean the area inside. Remove bobbin case and throat plate and clean stitch-forming mechanism.

After each cleaning, oil the machine as instructed on pages 46 and 47.

If the machine is to be stored for an indefinite period, brush away all traces of lint and fluff, then swab all exposed parts with a lint free brush saturated with SINGER* oil to protect against rust damage.

The area in head of machine that should be cleaned and covered with a protective coat of oil is shown at left.

Also clean stitch-forming mechanism and cover exposed parts with a coat of oil.

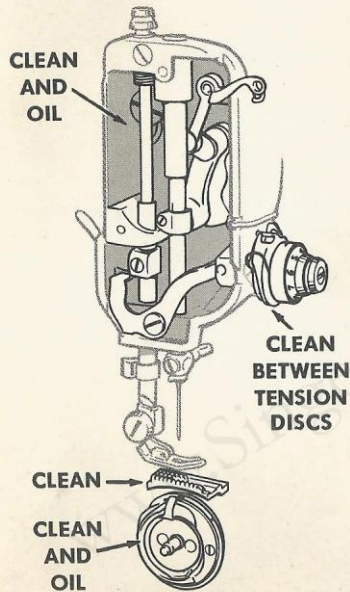

TO OIL THE MACHINE

To keep your machine in top condition, use SINGER Oil and SINGER* Lubricant.

Both are quality products especially prepared for sewing machines, and should always be used in the care of your 221K5.

- Clean the machine periodically as instructed on page 45.
- Apply a drop of oil to each place indicated.

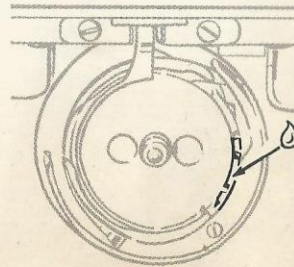
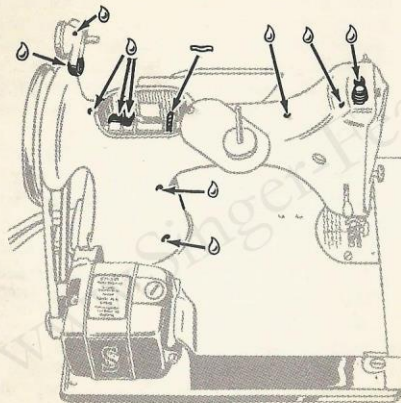

TO OIL THE MACHINE—(Cont'd)

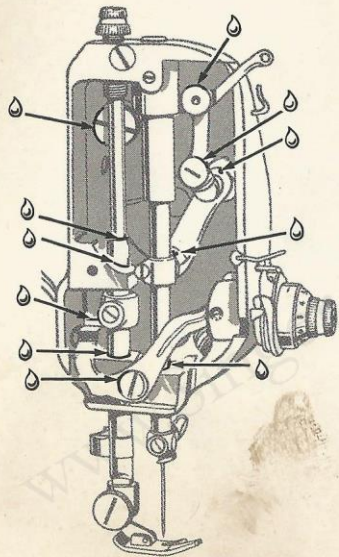

Remove thumb nut, felt washer and cover plate from underside of machine. Apply oil to each place indicated below.

Apply a small amount of SINGER Motor Lubricant to the gears.

Replace bottom cover.

NEVER APPLY OIL TO THE GEARS.

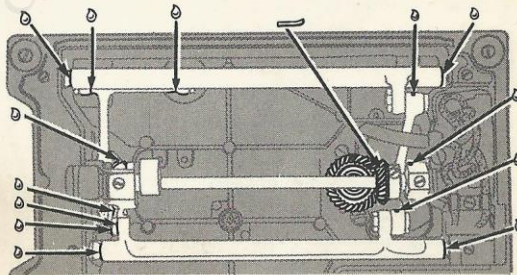

TO LUBRICATE THE MOTOR

NEVER USE OIL OR ORDINARY GREASE ON THE MOTOR. FOR BEST RESULTS, USE SINGER MOTOR LUBRICANT furnished with the machine. When the machine is shipped from the factory, the two grease tubes, indicated by arrows, are filled with enough lubricant for approximately six months' use.

Refill grease tubes at least once each six months by inserting tip of lubricant container into grease tubes and squeezing enough lubricant into each tube to fill it.

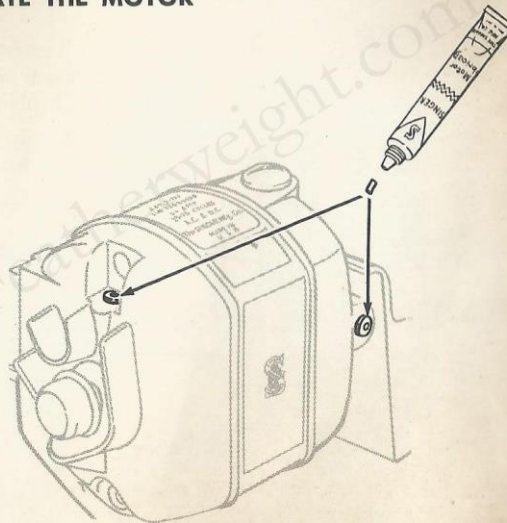

LIGHT

The light is turned "on" or "off" by the switch located on bed of machine at the right.

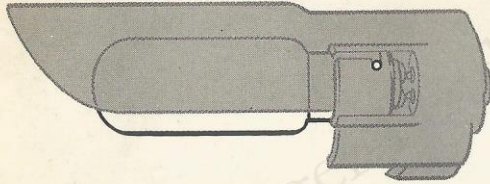

To Remove Bulb. Press bulb into socket and turn it in "unlock" direction, as shown, and withdraw.

To Replace Bulb. Press bulb into socket with bulb pin in slot and turn it in "lock" direction, as shown.

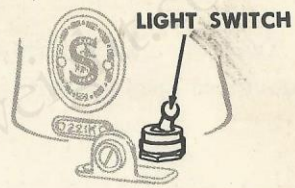

LOCKS

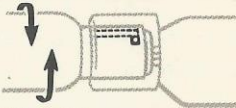

UNLOCKS

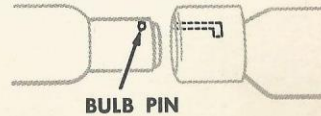

BULB PIN

BELT TENSION

Tension on the belt should be only heavy enough to keep the belt from slipping.

To adjust—

- Loosen bracket screw (A) a full turn.
- Allow weight of motor to supply correct belt tension.
- Tighten bracket screw.

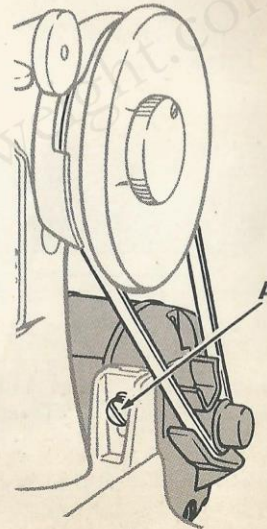

TO PACK MACHINE

Place attachment box in its compartment at left of carrying case, as shown below. Turn up machine bed extension and place machine in case with hand wheel at right and base of machine at right of wooden strip at bottom of case.

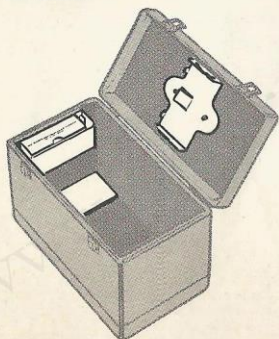

Slide controller from right to left into its holder in lid of case and place electric cord at rear of machine, as shown above.

INDEX

	PAGE		PAGE
Attachments	23-40	Edge Stitcher	43
Foot Hemmer	24-26	Gathering Foot	43
Binder	28-30	Tucker	44
Ruffler	35-40	Zigzagger, Automatic	41
Seam Guide	27	Principal Parts of Machine 221K5	3
Zipper Foot	31-34	Maintenance of the Machine	
Belt		Oiling and Lubrication	46-48
To Regulate Belt Tension	50	To Clean the Machine	45
Bobbin		Needles and Thread	5
Removing	7	Needle Insertion	5
Winding	8-9	Pressure Adjustment	19
Bobbin Case		Sewing	
Removing	7	Guiding and Supporting Fabric	18
Replacing	11	Prepare to Sew	14
Threading	10	Sewing a Seam	15-17
Carrying Case		To Regulate Length of Stitch	13
To Pack Machine in Case	51	SINGER Service	2
Chart for Fabric, Thread, Needle		Threading	
and Stitch Length	4	Bobbin Case	10
Darning	22	Needle	12
Electrical Information		Thread Tensions	
Light	49	Bobbin Thread	21
Motor	6	Needle Thread	20
FASHION Aids			
Buttonholer	42		

To all whom it may concern:

The improper placing or renewal of the trademark **SINGER*** or any other of the trademarks of The Singer Manufacturing Company (all of which are duly Registered Trademarks) on any machine that has been repaired, rebuilt, reconditioned, or altered in any way whatsoever outside a SINGER factory or an authorized SINGER agency is forbidden.

Form K6436
(861)

Printed in Great Britain

For your protection

SINGER Sewing Machines are sold and serviced wherever you see the famous SINGER and Red "S" Trademarks. When your machine needs servicing call your SINGER SEWING CENTER to be sure of warranted SINGER parts and service. See address in the classified telephone directory.

SINGER SEWING MACHINE COMPANY