

# ALZO PRODUCT SPECIFICATION

## 2G11 LAMP HOLDER

Part #: 1094 UPC:658580200824

For pricing email - [csupport@alzodigital.com](mailto:csupport@alzodigital.com)  
or phone 800-582-7009



### RoHS COMPLIANT

#### Specifications

For Use With	2G11 CFL UV lamps, All 2G11 base CFL lamps
RoHS Compliant	YES
Shell Material	PBT (Polybutylene Terephthalate)
UV Stabilizer	2-(2'-hydroxy-5'-(1,1,3,3-tetramethylbutyl)phenyl)benzotriazole
Color	Violet
Current Rating	2 Amps
Connections	Bottom entry - Solder-less Quick Connect 18 AWG solid copper
Depth	18.5 mm
Height	37.5 mm
Width	47.4 mm
Temperature Max	140C
Voltage Max	400V
Weight	14g

#### Certifications Pending

UV degradation - UL 746C  
UL 496, 13th edition  
CSA C22.2 no 43, 6th edition



#### PHYSICAL

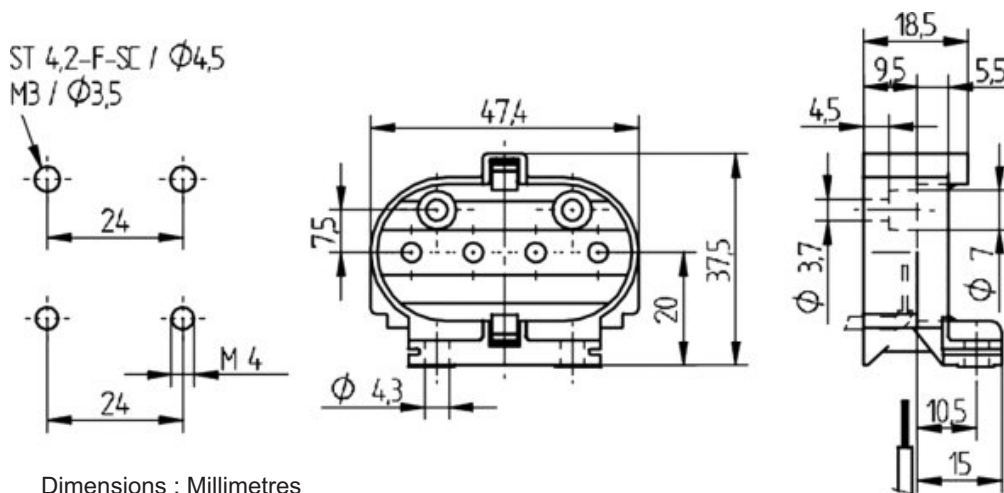

**Important Notice** : This data sheet and its contents (the "Information") belong to ALZO Digital (ALZO). No licence is granted for the use of it other than for information purposes in connection with the products to which it relates. No licence of any intellectual property rights is granted. The Information is subject to change without notice and replaces all data sheets previously supplied. The Information supplied is believed to be accurate but ALZO assumes no responsibility for its accuracy or completeness, any error in or omission from it or for any use made of it. Users of this data sheet should check for themselves the Information and the suitability of the products for their purpose and not make any assumptions based on information included or omitted. Liability for loss or damage resulting from any reliance on the Information or use of it (including liability resulting from negligence or where ALZO was aware of the possibility of such loss or damage arising) is excluded.