





CONTENT

String – The story	06
1949 – 1959	20
1960 – 1969	28
1970 – 1979	36
1980 – 1989	42
1990 – 1999	48
2000 – 2009	56
2010 – 2019	62
2020 –	68
Colours & dimensions	76
String Pocket	80
String Outdoor	82



In 1949, Bonniers Folkbibliotek, one of Sweden's largest publishers, decided to hold a design competition for a new kind of bookcase. The winner: String, by Kajsa & Nisse Strinning.

STRING – THE STORY

String has earned its place in design history thanks to its elegant simplicity and ingenious construction. Designed by Nisse and Kajsa Strinning, the String shelf won its first design prize in 1949. Based on three simple elements – the shelf, the wall panel and the metal fitting – it can be combined in an infinite number of configurations and is endlessly reinvented as it passes from one generation to the next. This year, String celebrates its 75th birthday.

ALL BOOKS AND NO SHELVES

In the late 1940s, vast number of books were being sold in Sweden. Even the smallest town had its own bookshop, and salesmen often peddled their wares in the workplace. With Swedish homes overflowing with books, the question naturally arose: where should they all be kept? Bonniers Folkbibliotek, one of Sweden's largest publishers, decided to answer this question by holding a design competition in the spring of 1949. They called for a new kind of bookcase that would be affordable, wall-mounted, expandable and hold at least two metres of books.

NISSE STRINNING

At this time, a young Stockholm architect called Nisse Strinning had just begun his career. Although a trained architect, Nisse was actually more interested in designing smaller everyday objects that could have a big impact on people's lives. As a child, he had designed and built his own bookcase. As an adult, he had all the theoretical knowledge and practical experience needed to recreate that bookcase... making it open, affordable, space-saving, and expandable to any size. In fact, when Nisse heard about Bonniers' bookcase competition, the idea of the String bookshelf was almost ready to go.

KAJSA CRACKS THE DETAILS

At this point, it would be remiss not to mention Strinning's wife Kajsa – also an architect – without whom the String shelf might never have past the prototype stage. Unlike her husband, Kajsa had the artistic talent to refine Nisse's raw industrial designs, and the patience to create the detailed technical

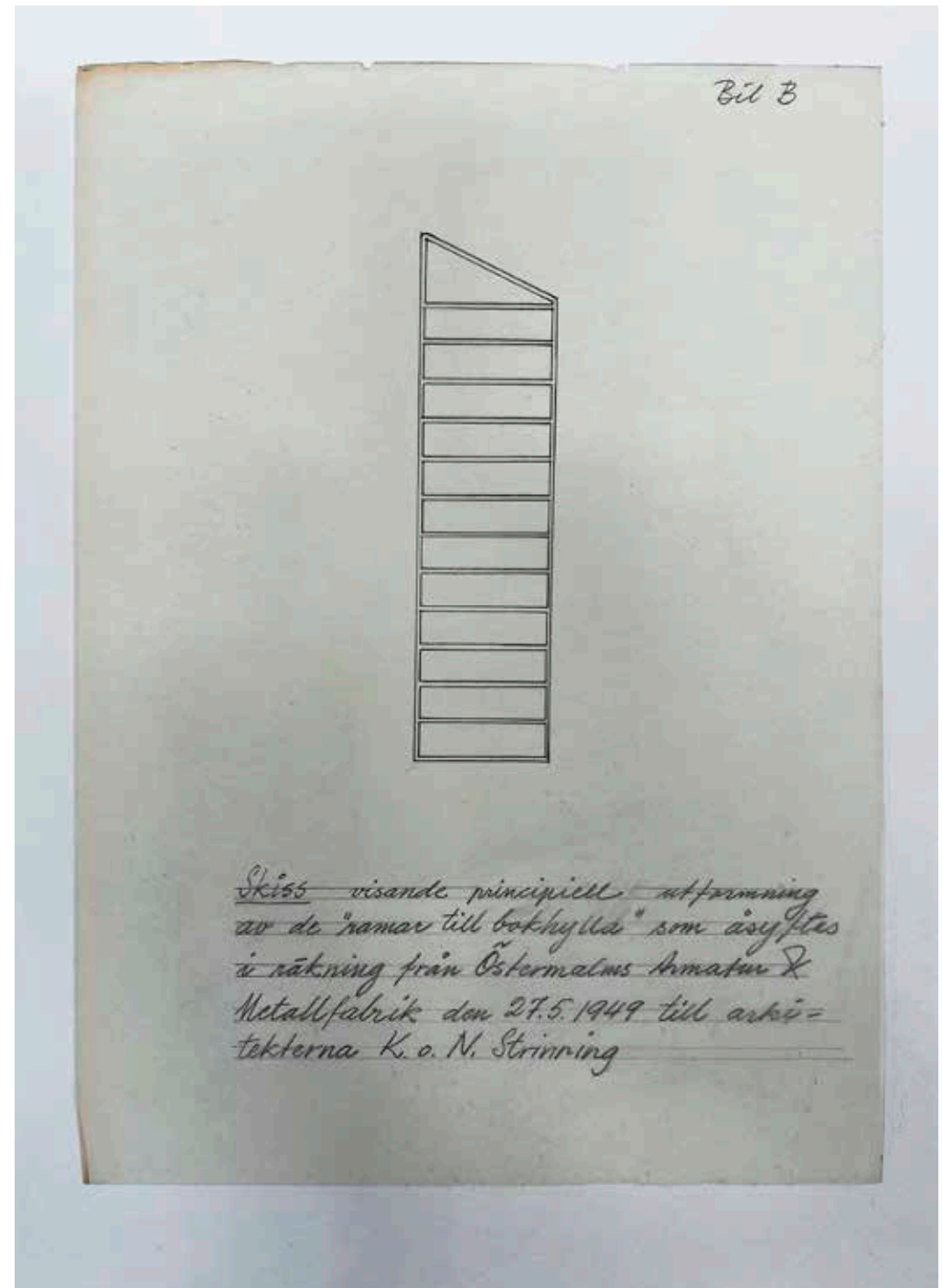

The original drawing.



drawings needed to construct his bookshelf. Together, they formed a winning team.

CHILDREN OF THEIR TIME

Like most inventors, the Strinnings did not work in a vacuum but were influenced and carried forward by the powerful currents of their time. The post WW2 era was characterised by a strong sense of optimism. Everything seemed possible. Penicillin revolutionised the treatment of bacterial infections. Plastics revolutionised everyday life. The LP record and the transistor radio were invented. Fiat, Volkswagen, Volvo and SAAB launched small, inexpensive vehicles that meant ordinary people could realise the dream of owning a car. In Paris, Christian Dior's 'New Look' triggered a fashion revolution. The world of furniture also saw an explosion of ground-breaking designs. For example, the American couple Charles and Ray Eames announced their ambition to "offer the best of the best at the lowest price to as many people as possible". They designed the iconic fibreglass chair with 'Eiffel' metal base – an idea which Harry Bertioia then took to the extreme with his Diamond Wire Armchair.

MAKING GOOD DESIGN AFFORDABLE

When it came to improving the daily lives of its people, Sweden was ahead of the curve. The clothing company, H&M was founded in 1947 and, in the same year, the department store NK opened its first home interiors department, showcasing the new design aesthetic that young people loved. A wealth of new, mass-produced products appeared, reflecting contemporary ideals; affordable everyday objects that added elegance to the homes of the new, forward-thinking generation.

STRING WINS THE CONTEST

In the autumn 1949, Nisse and Kajsa's String shelf won first place in Bonniers' bookcase competition. Made of blue wall panels and pine shelves, their design beat 194 entries from around Europe, the US and even as far away as Australia. Commercial production began soon afterwards, with only one small modification. The dimensions were adjusted to ensure that the wall panels and shelves could be packaged and sold in the same box.

AN INGENIOUS CONSTRUCTION TURNS INTO SUCCESS

The construction of the very first shelf was based on three simple elements; the shelf, the wall panel and the metal fitting. The dimensions of the shelves and wall panels were 78 cm wide, 75 cm high and 20 cm deep – exactly the same as they are



Nisse Strinning was constantly working on new ideas for the String System. The transparent wall panel 'Plex' made of perspex was designed in 1953 and relaunched in 2009.



String quickly found its way into offices, even the UN building in New York.

today. Meaning you can connect a String from 1949 with another from 2024. After a few short months, String became known all over Sweden, and in less than a year over 40,000 systems had been sold. With the money, Nisse buys "A typerwriter and a car". He chooses an Olivetti typewriter and a Standard Vanguard car.

INTERNATIONAL SUCCESS

In the years that followed, the String shelf began to appear in interior design magazines, at trade fairs and other important exhibitions. It continued to sell well in Sweden, while its popularity spread to the rest of Europe, the United States and South America. String shelves were used in the offices of the UN Headquarters in New York, and in 1954, String was awarded a gold medal at the Milan Triennale. In the summer of 1955, an Art Industry Exhibition known as the H55, was held in Sweden, with nine nations participating: Denmark, Finland, France, Japan, Norway, Sweden, Switzerland, United Kingdom, and West Germany. The Strinnings took the opportunity to present several additions to their range as part of the 'Home and Interior Design of the Future' exhibition. These limited-edition tables, chairs and sofas soon became sought-after collector's items.

THE GREATEST FORM OF FLATTERY

As was the case with many other 1950's designs, String had neither patent nor copyright protection, and numerous copycat products were launched in the wake of its success. By the time the design was finally legally protected in 1961, Nisse's lawyer had collected over a hundred more-or-less accurately plagiarised designs from around the world. As they say, imitation is the greatest form of flattery.

FROM DURABLE TO DISPOSABLE

By the early 1970s, enthusiasm for String was dying down. Modernism gave way to postmodernism. Simplicity, straight lines and open spaces, gave way to rounder shapes, brighter colours and lower prices. Consumers were attracted to modern disposable products, which were a far cry from the durable String System that could be passed down from generation to generation and used for every room in the house. Sales declined and the shelves that had once 'modernised' the living room were sidelined into the kid's bedrooms or garage storage.

MODERNISM MAKES A COMEBACK

In the early 1980s, Modernism began to make a comeback. Furniture enthusiasts and auction houses noticed that interest in the bentwood of Alvar Aalto had picked up. And there was a newfound interest for functionalism, the Danish golden age of

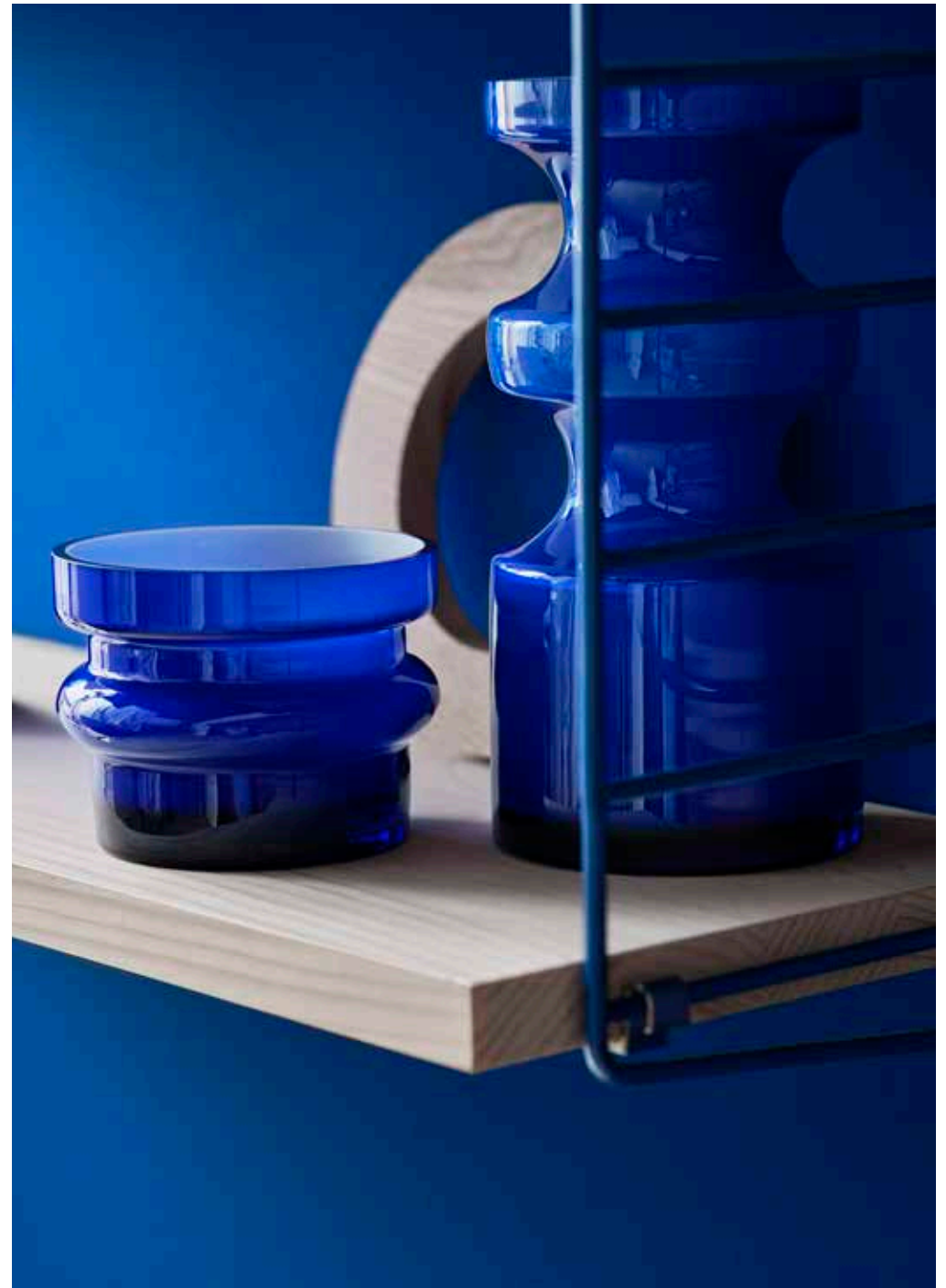

The 75th anniversary String, limited edition. Blue wall panels and shelves in pine. Just like the winning design from 1949. Following page: Kajsa Strinning. Architect, designer and co-creator.



Wegner, Jacobsen, Kjærholm, as well as Eames, and of course Kajsa and Nisse Strinning's String System.

In 1985, the Swedish auction house Bukowskis, made the bold move of holding a Nisse Strinning exhibition. Some wondered how such a well-known, everyday product could be classified as a design classic. But Bukowskis' intuition proved right. It soon became clear that String had reached iconic status among design collectors and the designer couple were now seen in a new light.

OPPORTUNITY KNOCKS

Fast forward to November 2004, when Ulrika and Peter Erlandsson opened a small design shop in southern Sweden. A customer came in asking if anyone knew of the "String shelf", and if so, how she could get hold of one. Although the owners had no idea of the answer, they found the question intriguing. Peter did some research and was surprised to learn that production of String had stopped and the manufacturer had been declared bankrupt.

On a whim, Peter contacted the bankruptcy administrator to find out if and when manufacturing could start again. He found himself asking if it was possible to take over the rights to String production. The administrator referred him to Nisse Strinning. Before going any further, Peter called his partner Pär Josefsson, and the two of them agreed to pursue the opportunity together.

A couple of weeks later, Peter and Pär visited the Strinning's home. Peter remembers that the house was visible from a distance, with its garden full of artworks. Nisse lived upstairs with his sketches and prototypes while Kajsa lived on the ground floor with her drawings. But that day, the couple was waiting together in the kitchen with a huge freshly baked cake which spelt out the word S-T-R-I-N-G.

'THE BOYS' TAKE OVER

In 2004, Peter and Pär – whom Kajsa and Nisse endearingly referred to as 'the boys' – bought the rights to manufacture, distribute and sell String worldwide. All four shook hands on the deal and a brand new chapter of String Furniture began. The following year the new range in a contemporary all white version, was presented at H05 in Helsingborg – the very same place where the original design had received so much attention fifty years earlier. The familiar shape of the String system felt at once both classic and modern.

THE LEGACY LIVES ON

Today, String comprises of an entire system and can be combined in an infinite number of configurations. New colours, materials,



1949 on the left, 2024 on the right. The original dimensions have stayed exactly the same since the very start.

and accessories have been added over time. Some of them blueprint ideas from Nisse's archives; others created by contemporary Swedish designers. Although the system is endlessly being reinvented as it passes from one generation to the next, its basic construction – the shelf, the wall panel and the metal fittings – remain identical to the 1949 original.

String Furniture continues to grow in Europe, the US and Asia, and is currently sold in 48 countries. Manufacturing still takes place in Sweden just as in 1949; with the wall panels being made just a few kilometres away from where the shelves are produced. From here, everything is packaged and shipped worldwide.

Although Nisse passed away in 2006 and Kajsa in 2017, their designs are still very much alive and thriving. This year, String celebrates 75 years and there are still thousands of combinations to discover.



String has always been manufactured in Sweden. Here's a still unopened box from 1954, delivered from the factory in Totebo, Småland – where String is still made today.

1949–1959

The String shelf is born and Christian Dior launches The New Look. TV becomes a mass medium, Elvis Presley is crowned 'The King of Rock and Roll'. The Cold War escalates. Pop art is born and Laika the dog is launched into space. Interior design goes modern. Eames, Kjærholm, and of course Strinning, clear the floors and make room for living.





Oak, walnut and thin black lines. Distinct and soft at the same time. Characteristically timeless.





Can you spot the new one? Display cabinet in a narrower version, 58 cm width. Metal magazine shelf – born classic.

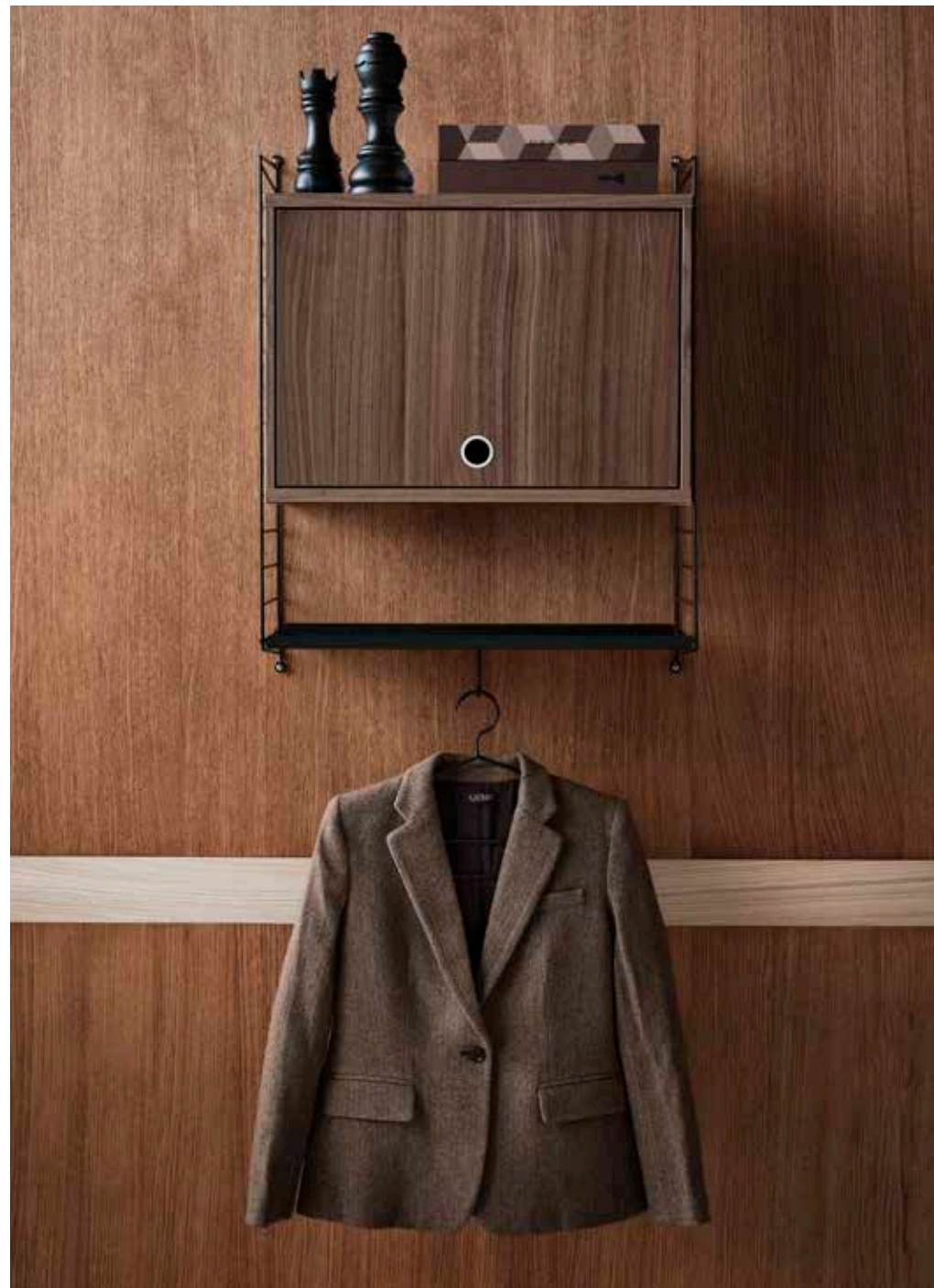

Additions in 2024: Cabinet with flip door and display cabinet, both 58 cm wide.
Left: Vintage shelf combined with metal shelf low edge.

1960–1969

Mary Quant, Twiggy, the Beatles or the Stones. The Berlin Wall is built. JFK, Che Guevara and MLK are assassinated. Neil Armstrong lands on the moon. The 'Summer of Love' in San Francisco. The Pill and the Shinkansen train make their debut. Colour rocks the world and pops up everywhere. Like a Mondrian painting.



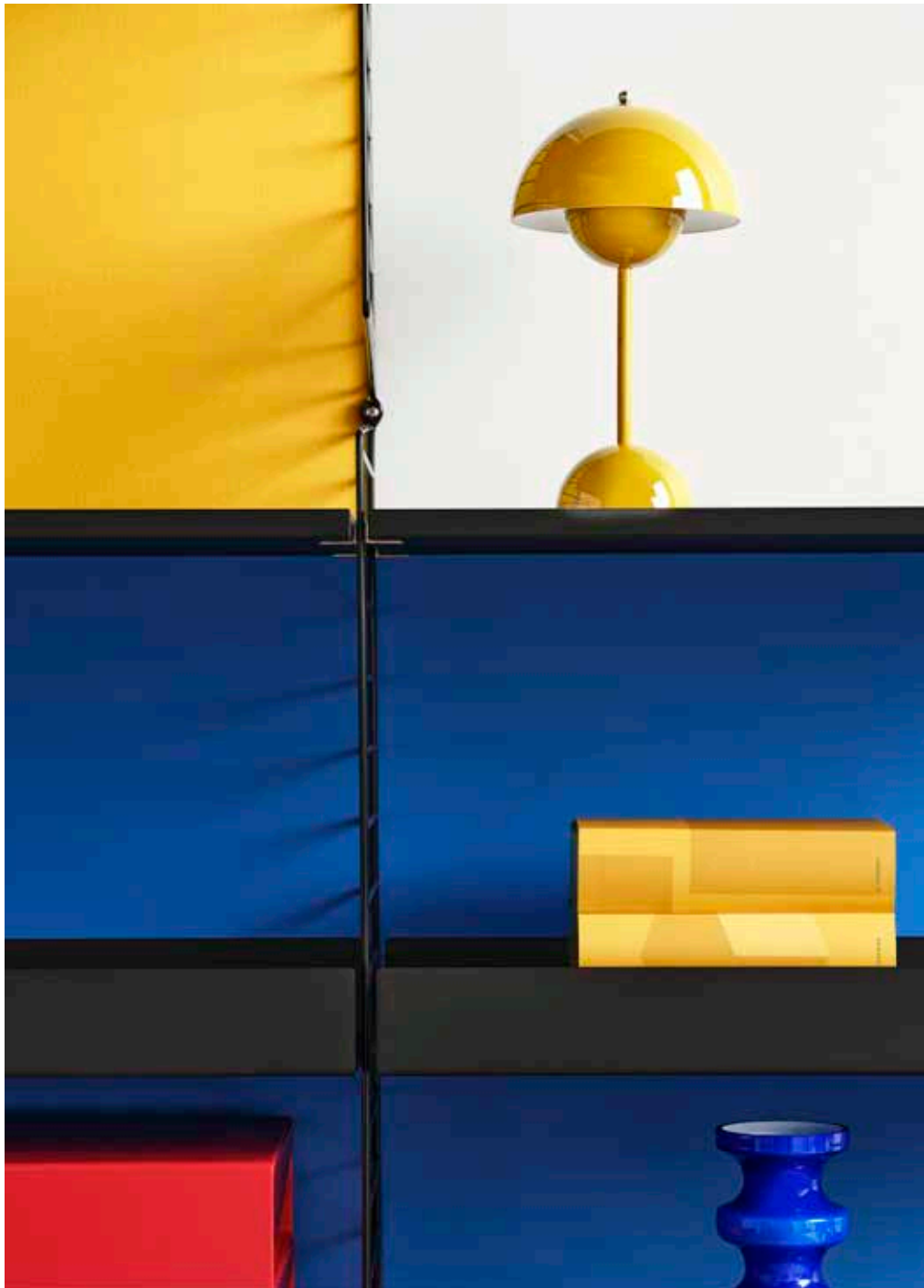

Black wall panels and metal shelves, mix of high and low edges.
Following page, right: 50 cm black wall panels, metal shelves with high and low edges.



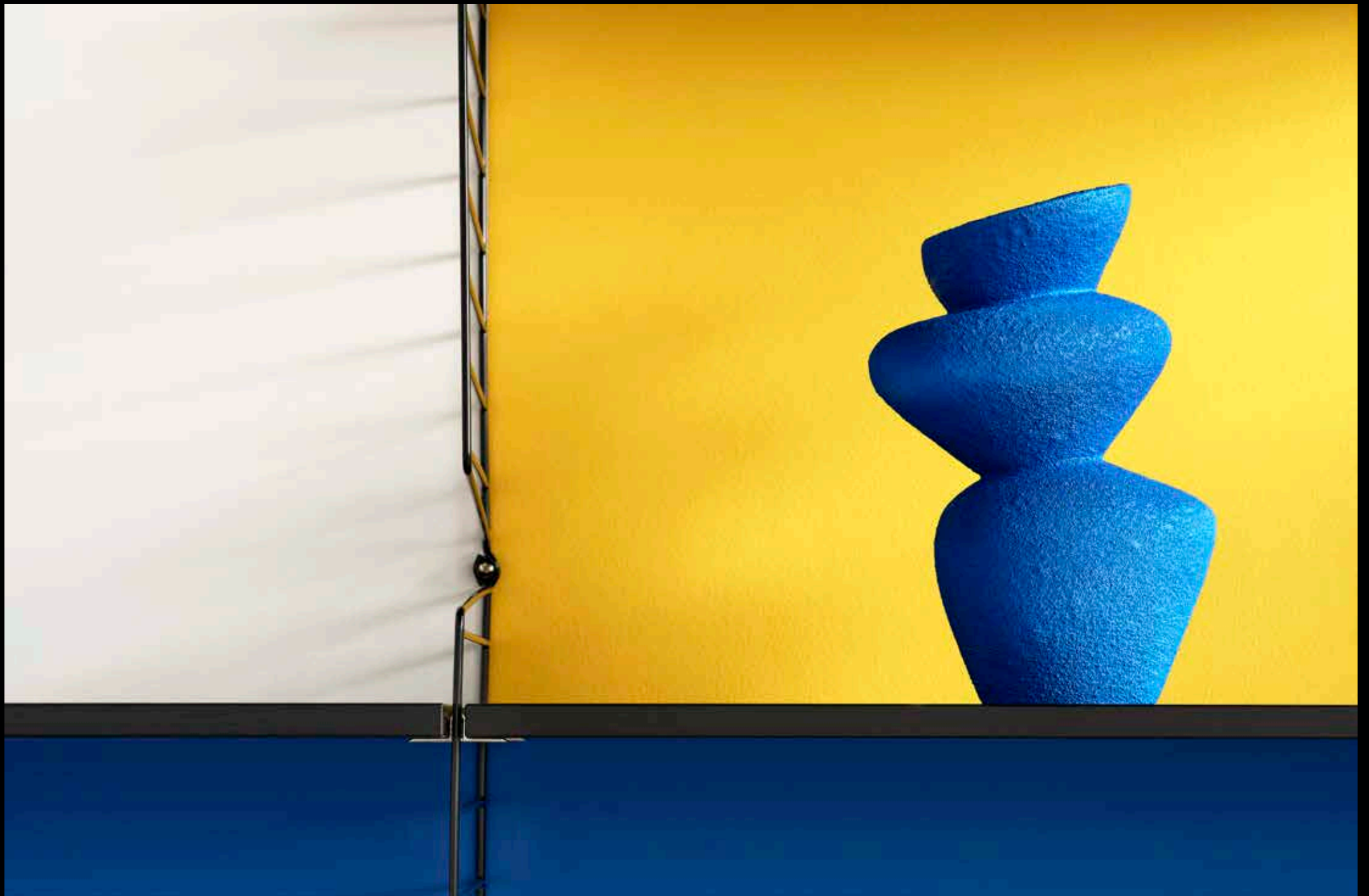

1970 – 1979

The Watergate scandal and the Vietnam War ends. The Sony Walkman and VHS video are launched, Jobs and Wozniak start Apple. The bookshelves are full of Ludlum, Solzhenitsyn and Jong. Nature comes into our homes, and it doesn't wear perfume or makeup. It's terracotta, cork, and brownish off-white. But there is still room for ABBA, Kiss and the Sex Pistols.





Tiny cabinet in oak, a new edition. Mirrored inside for hidden glamour.

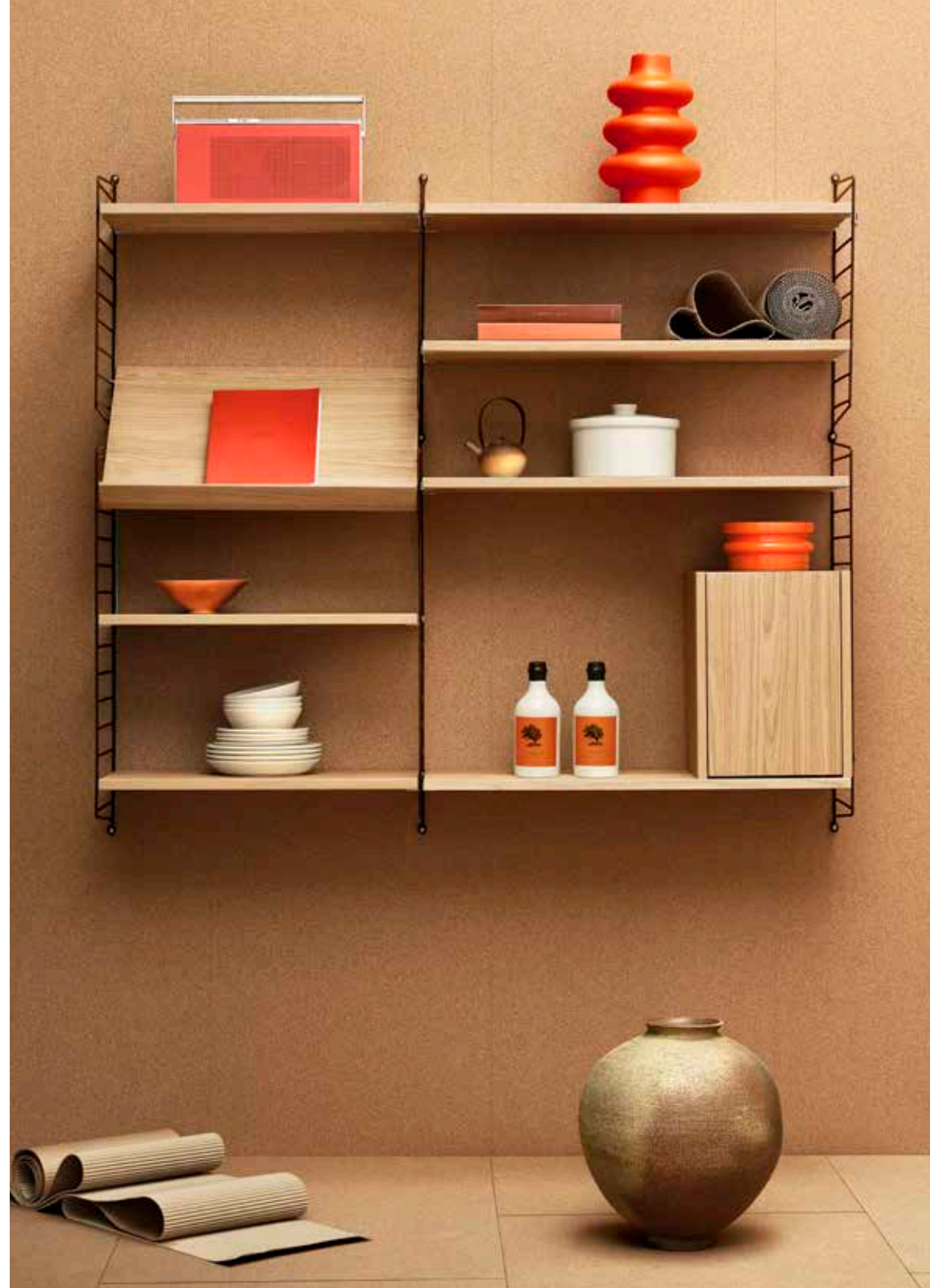

Oak shelves with wall panels in brown.
Right: Magazine shelf, and Tiny cabinet holding secrets.

1980–1989

Maradona scores the goal of the century. Pac-Man is eating power pellets. ET wants to phone home and Michael J Fox travels back to the future. Jean-Paul Sartre dies and Kim Kardashian is born. Memphis moves to Milan and nothing is an everyday object anymore. A teapot, corkscrew and a citrus press becomes art, geometrical and dipped in pastels, layered in black and white.



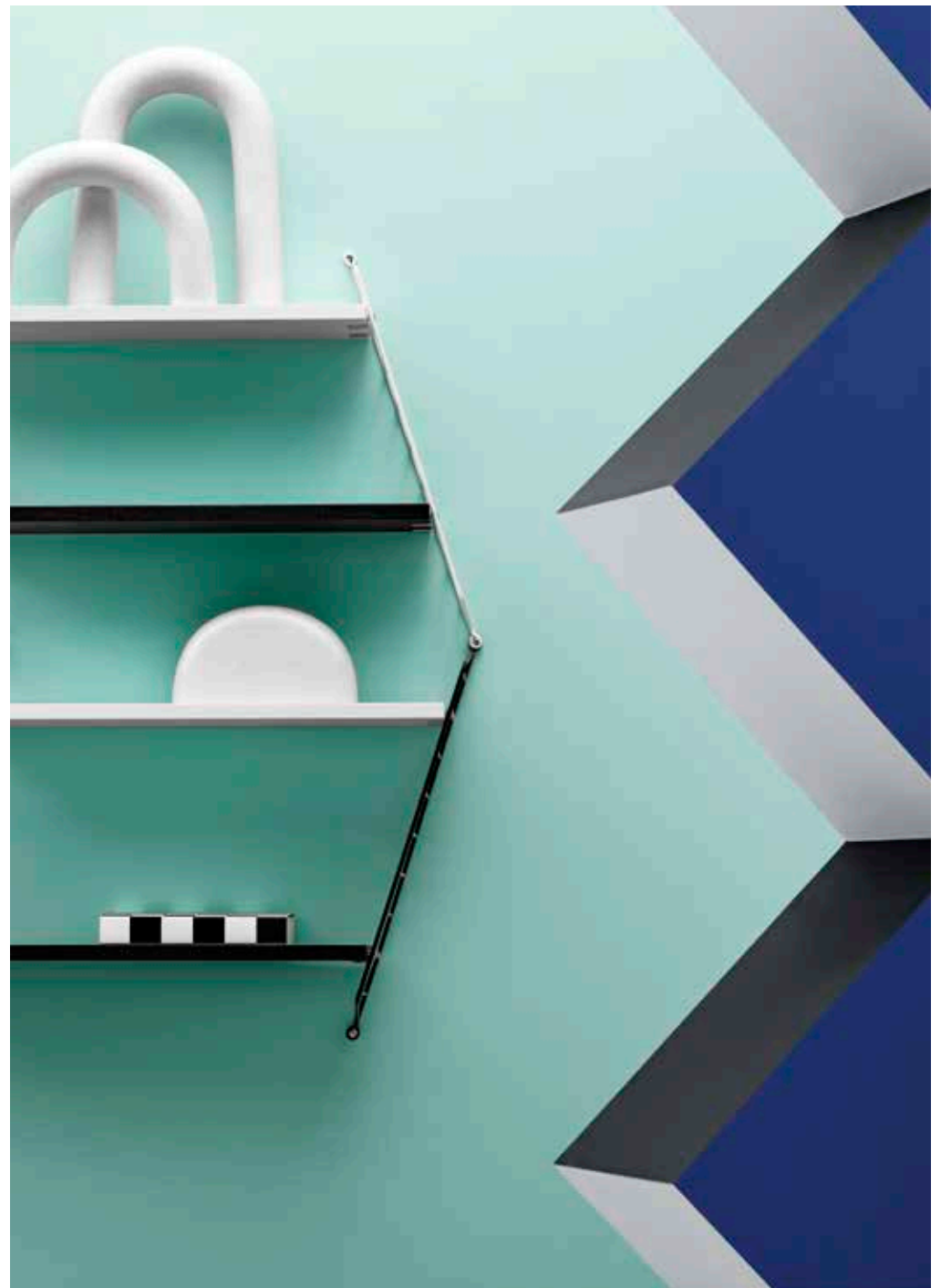

Left: String Pocket metal in blue above a grey combination. Folding table and Cabinet with sliding doors.
Above: Wall panels in black and white, with metal shelves in black and white. Or liquorice?



Wall panels in white and black, 50 x 20 cm. Metal shelves, 58 cm, and 78 cm wide. Mix to the max.

1990–1999

Yahoo is the world's largest search engine. The Berlin wall falls and Nelson Mandela is released from prison. We watch Friends and Seinfeld. Clinton did not have *** with Lewinsky. Harry Potter and Philosophers Stone is published. Primary colours become unstoppable. Without flinching, they move up the wallpapers, down the curtains, across sofas, into the wardrobes.

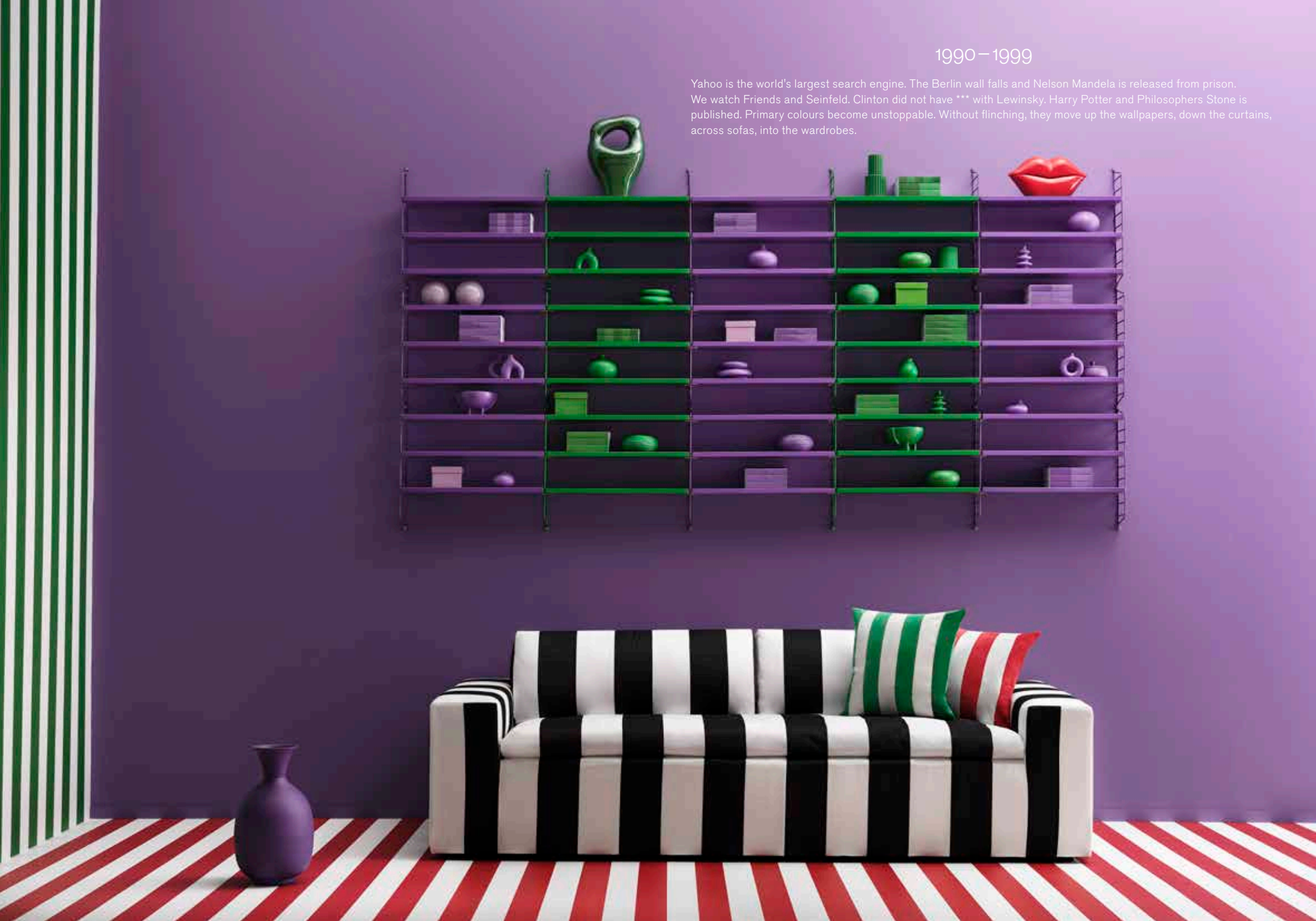



String Pocket in purple and green. Aligned or just linear?

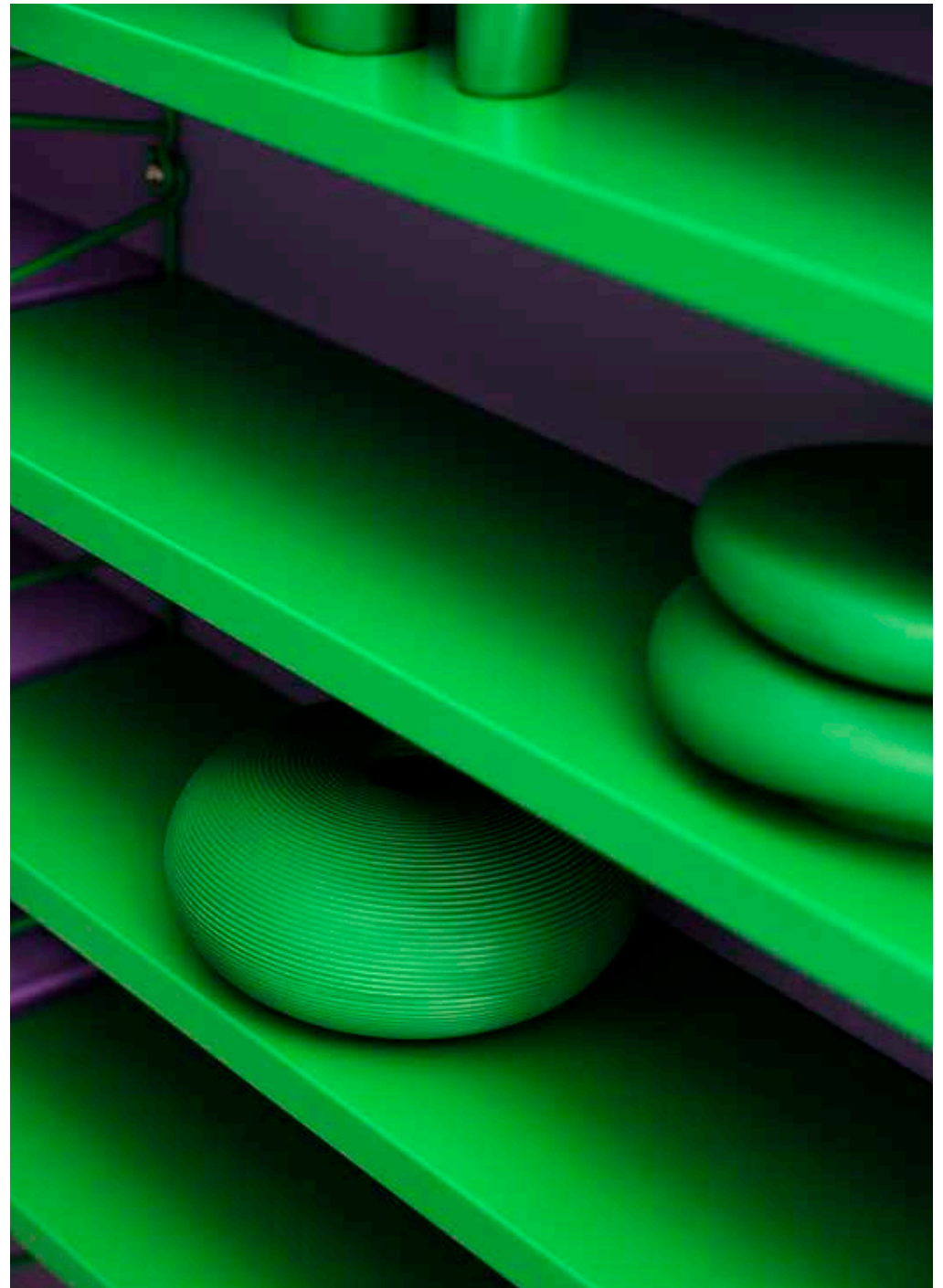



White floor panels and metal shelves with high edge.
Right: String Pocket. Horizontal.





2000–2009

The Y2K bug becomes a topic and Mark Zuckerberg starts Facemask, which becomes Facebook. The world's first space tourist checks in at the ISS. The first smart phone is released and we start downloading apps. White strikes back. Crisp, sweeping and very bright. Fortunately, there are some harmonious accents. White as snow, warm as spring sunshine.





Magazine shelf and Media shelf.
Left: Shelves in black stained ash, together with low edge metal shelf and hook.



White and white on white. Photogenic.

2010–2019

We drive Tesla cars, read 'Fifty Shades of Grey' and join the MeToo movement. The UK votes for Brexit. The hipster hat, the MAGA cap and The Pussyhat are born. Wikileaks leaks, we book Über rides and drones start delivering pizza. We discover spirituality and take very slow breaths, until a calm emerges in soft colours, like a vague scent of incense.



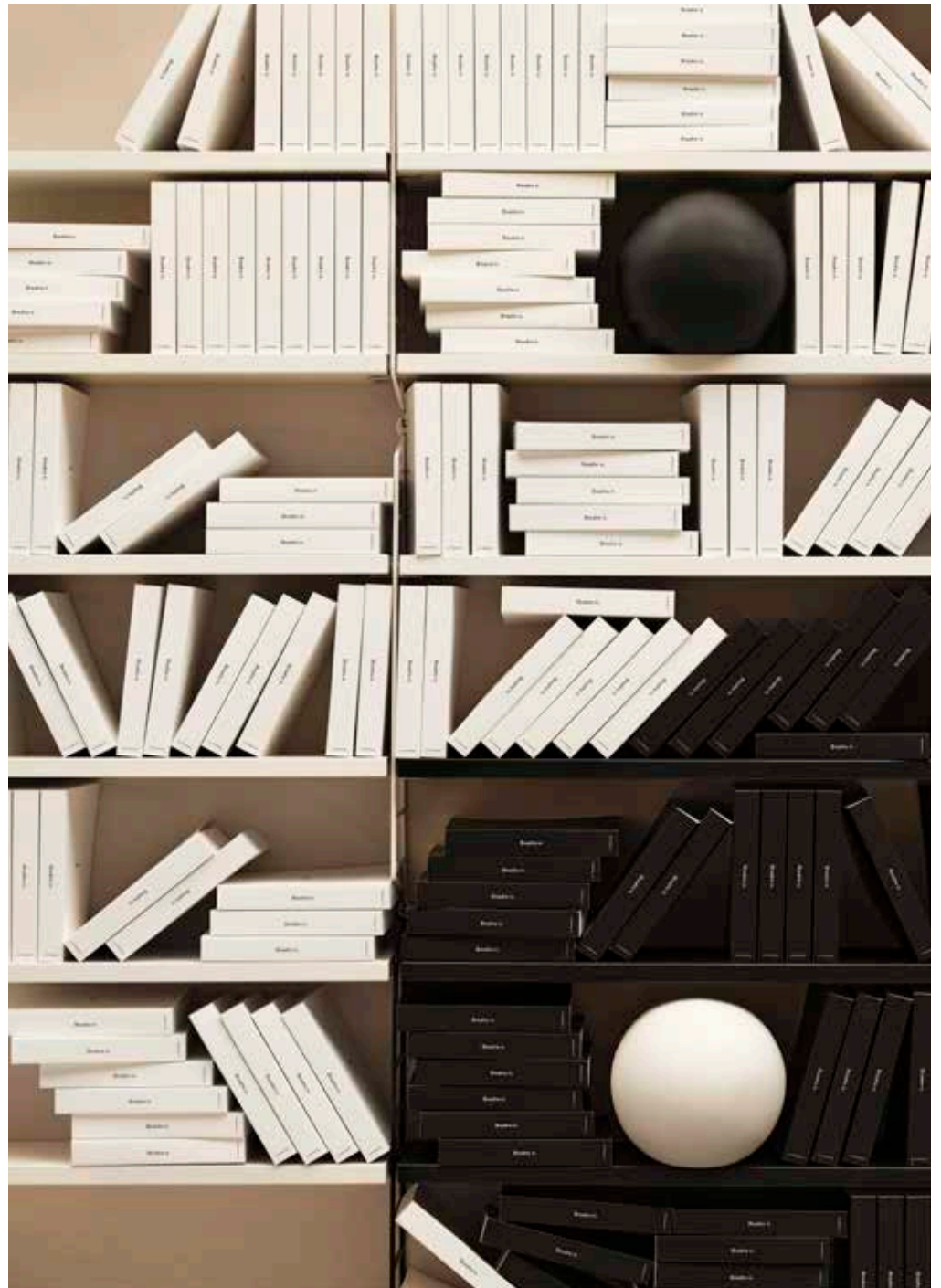

Left: Breathe in. Furnish up. Breathe out. Oak shelf with wall panels in white.



Beige metal shelves with hooks. Everything in its place, inside and out.
Right: White wall panels with magazine shelf in oak.



2020—

Covid-19 shuts down everything and Artificial Intelligence is available to the everyone. Prince Charles becomes king and Barbie is the highest grossing film of 2023. Nature calls and tell us it has waited long enough to be invited. So, we open the door and promise to be a better friend in the future. It is decided, we will be inseparable.

String turns 75 and there are thousands of combinations yet to be discovered.





Shelves in oak and black stained ash. Black wall panels tilted 17 degrees. Sweet!



Free standing combination in galvanized steel. Made for the great outdoors. Works just as well for indoor gardening.



Discover your String combination.

The String System is a series of components featuring the classic wire panels that offer almost unlimited combinations. You can choose among a wide range of colours and materials to build your own, personal shelving system, based on standard widths of 60 cm and 80 cm and two depths, 20 cm and 30 cm.

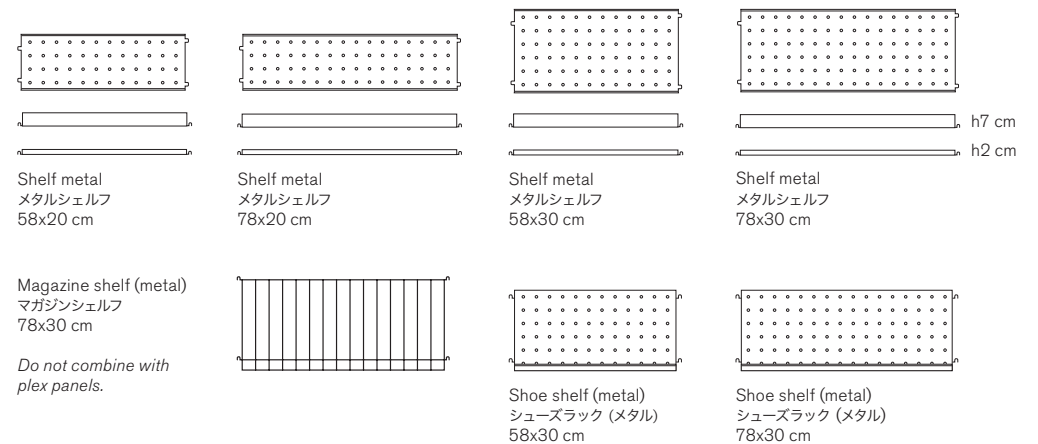
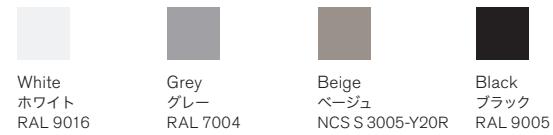
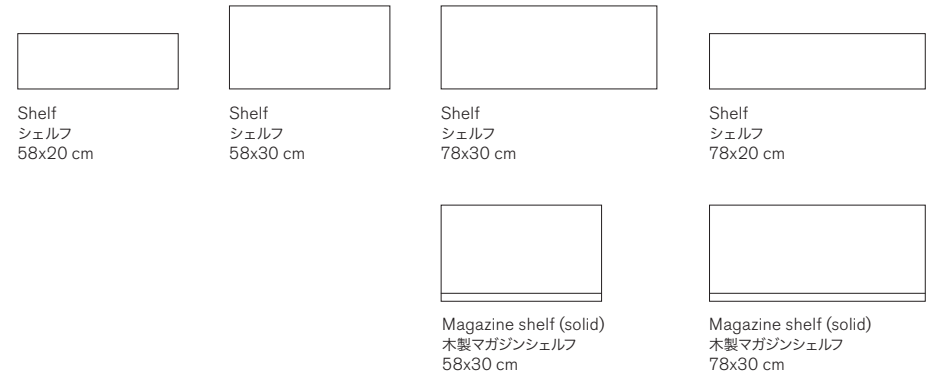
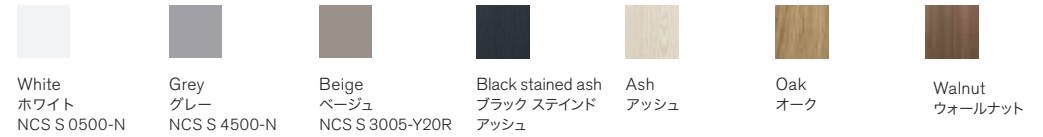
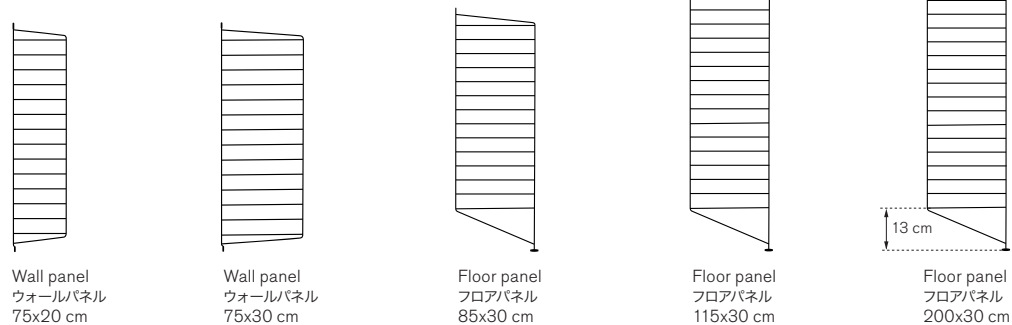
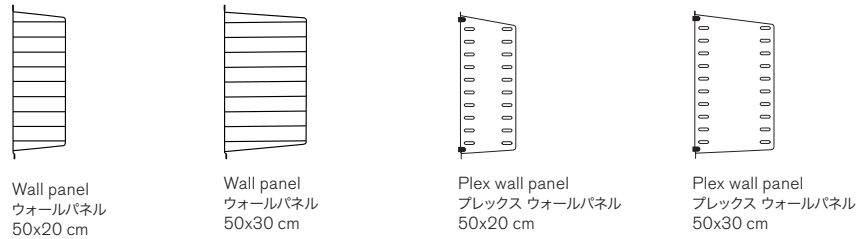



White
ホワイト
NCS S 0500-N



Grey
グレー
NCS S 4500-N



Beige
ベージュ
NCS S 3005-Y20R



Black stained ash
ブラック ステインド
アッシュ



Ash
アッシュ



Oak
オーク



Walnut
ウォールナット



Anthracite
NCS S 7500-N
ダークグレー



White
NCS S 0500-N
ホワイト



White
ホワイト



Light grey
ライトグレー

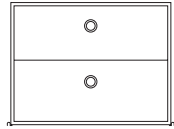

Chest of drawers
チェスト
引き出し
w58/d30/h42 cm
Inside depth 23 cm
内寸奥行 23 cm

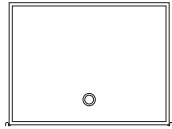

Cabinet with flip door
キャビネット
w58/d30/h42 cm
Inside depth 28,5 cm
内寸奥行 28,5 cm

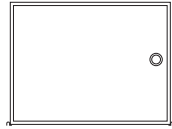

Cabinet with swing door
スイングドアキャビネット
w58/d30/h42 cm
Inside depth 26 cm
内寸奥行 26 cm

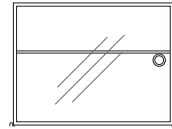

Display cabinet with
swing glass door
ディスプレイキャビネット
w58/d30/h42 cm
Inside depth 26 cm

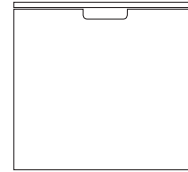

Media shelf
メディアシェルフ
w58/d47

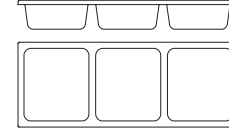

Bowl shelf
(ABS plastic 60% reused),
ポウルシェルフ (ABS 60%再生樹脂)
78x30 cm
Inside depth 8,5 cm
深さ 8,5 cm

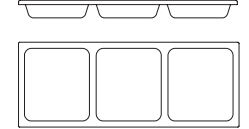

Bowl shelf (felt)
ポウルシェルフ (フェルト)
78x30 cm
Inside depth 5 cm, 深さ 5 cm

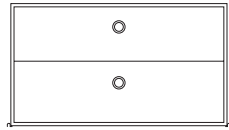

Chest of drawers
チェスト
引き出し
w78/d30/h42 cm
Inside depth 23 cm
内寸奥行 23 cm

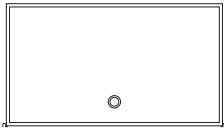

Cabinet with flip door
キャビネット
w78/d30/h42 cm
Inside depth 28,5 cm
内寸奥行 28,5 cm

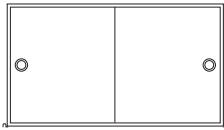

Cabinet with sliding doors
キャビネット
取り外し棚
w78/d30/h42 cm
Inside depth 26 cm
内寸奥行 26 cm

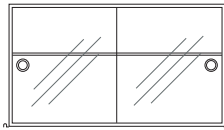

Display cabinet
ディスプレイキャビネット
w78/d30/h42 cm
Inside depth 26 cm
内寸奥行 26 cm

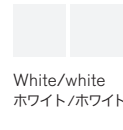

White/white
ホワイト/ホワイト



Grey/grey
グレー/グレー



Beige/beige
ベージュ/ベージュ

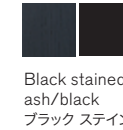

Black stained
ash/black
ブラック ステインド
アッシュ/ブラック



Ash/white
アッシュ/ホワイト

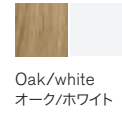

Oak/white
オーク/ホワイト

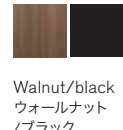

Walnut/black
ウォールナット
/ブラック

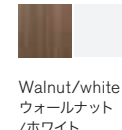

Walnut/white
ウォールナット
/ホワイト

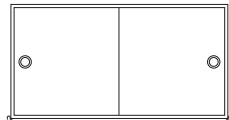

Cabinet with sliding doors
キャビネット
取り外し棚
w78/d20/h37 cm
Inside depth 16 cm
内寸奥行 16 cm

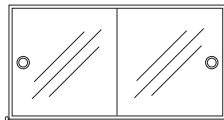

Cabinet with sliding mirror doors
Finns endast i vitt
ミラーキャビネット
ホワイト、グレー、ベージュのみ
w78/d20/h37 cm
Inside depth 16 cm
内寸奥行 16 cm

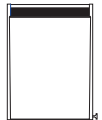

Tiny cabinet
タイニーキャビネット
w28/d30/h38 cm
Inside depth 28,5 cm

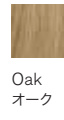

Oak
オーク

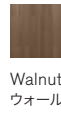

Walnut
ウォールナット

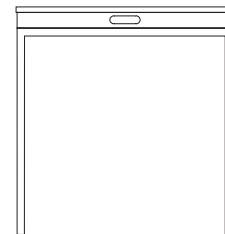

Folding table
折りたたみ式テーブル
w78/d96/h71 cm
Folding table – only with floor panels
折りたたみ式テーブル フロアパネルのみ対応

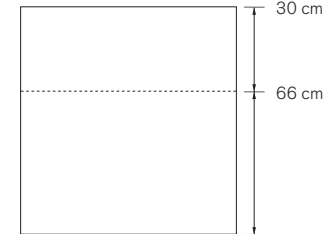

Work desk
ワークデスク
78x58 cm

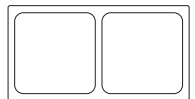

Desk drawer (ABS plastic
60% reused)
ポウルシェルフ
(ABS 60% 再生樹脂)
Depth 2 cm, 深さ 2 cm



White
ホワイト

String Pocket.

A beginning of something great.

String Pocket is the small, light and handy little one. W60/d15/h50 cm. It's sold as a complete unit of two panels and three shelves. Combine them in a number of ways. For example, with two units you can build up to three sections with two shelves each. The metal version adds new possibilities. Its shelves are thin and strong since the edges are folded. Also, they are perforated and ideal for adding accessories like hooks, rods and more.



White
NCS S 0500-N
ホワイト



Grey
NCS S 4500-N
グレー



Black stained ash/black
ブラック ステインダッシュ/ブラック



Ash/white
アッシュ/ホワイト



Oak/white
オーク/ホワイト



Walnut/black
ウォールナット/ブラック



Sage
RAL 7009
セージ



Green
NCS S 2070-G10Y
グリーン



Purple
NCS S 3050-R60B
パープル



Fuchsia metal
NCS S 1050 R20B
Fine textured
フクシア



Blue metal
NCS S 3060-R80B
Fine textured
ブルー



White metal
RAL 9016
ホワイト

String Outdoor. Wall mounted or free standing.

Galvanized metal makes it possible to take String outdoors. Furnish your favourite space freely, without being limited by four walls and a ceiling. The material can withstand any weather, and attains a nice rugged patina over time.

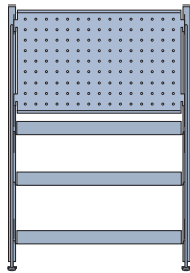

Galvanized
ガルバナイズド



Wall panel
ガルバナイズド
ウォールパネル
50x20 cm



Wall panel
ガルバナイズド
ウォールパネル
50x30 cm



Floor panel
ガルバナイズド
フロアパネル
85x30 cm



Upright
サイドバー
h87 cm

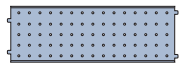

Shelf
シェルフ
58x20 cm
h2 cm

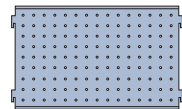

Back panel
フレーム 1枚入
w58/h36 cm

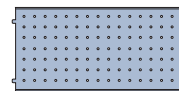

Shelf
シェルフ
58x30 cm
h7 cm
h2 cm

String Furniture
Limhamnsvägen 110
216 13 Limhamn, Sweden
stringfurniture.com



HOW TO SHOW OUR DESIGNERS RESPECT

All String Furniture products in this catalogue are protected by Swedish and international copyright. Copying them is forbidden by law. Our designers make a living from creating great furniture and they deserve to be fully appreciated for this, with the acknowledgement and royalties that only come with sales by String Furniture. Also, buying authorised products guarantees that they are developed and produced according to high sustainability and quality standards. Read more about this inside the catalogue or at stringfurniture.com.

This catalogue, including all images and text, as well as the design of the String® System, Museum, Works, Pira G2 and Relief, are all protected by Swedish and international copyright. The rights belong to String Furniture AB. String® is classified as a work of applied art under copyright law. The design of the Works desks is protected as a registered design in the European Union and a number of other countries. The String® brand name is owned by String Furniture AB and is registered in the EU, Norway, Switzerland, USA, China and other countries around the world. The String® shelving system was created in 1949 by the Swedish architect Nisse Strinning in collaboration with Kajsa Strinning. The Works desk was designed in 2013 and Pira G2 in 2023, by Anna von Schewen and Björn Dahlström. Museum was designed in 2018 and Relief in 2024, by TAF Studio.