

# Audo

COPENHAGEN



UMANOFF PLANTER  
Designed by *Arthur Umanoff*



UMANOFF PLANTER  
Designed by *Arthur Umanoff*

Offered in three different sizes, the Umanoff Planter marries sleek powder coated steel lines with curved handwoven rattan for a natural contrast. Designed in 1961 by the late Arthur Umanoff, a master of mid-century modern, the elevated planter is suitable for both indoor and outdoor use.



*Planter 27*



BLACK / RATTAN  
5710539

*Planter 32,5*



BLACK / RATTAN  
5711539

*Planter 69*



BLACK / RATTAN  
5712539

TECHNICAL SPECIFICATIONS

PRODUCT TYPE  
Planter

COLLI  
1

ENVIRONMENT  
Indoor  
Outdoor

DIMENSIONS

27  
H: 27 cm / 10,6"  
Ø: 27 cm / 10,6"

32,5  
H: 32,5 cm / 12,8"  
Ø: 41 cm / 16,1"

69  
H: 69 cm / 27,2"  
Ø: 36,5 cm / 14,4"

PRODUCTION PROCESS  
Welded steel rod, spun steel and  
handwoven natural rattan.

COLOURS  
Black (RAL 9005)

GLOSS  
Gloss 10-20 (with texture)

MATERIALS  
Powder coated steel, rattan

WEIGHT  
27: 2,4 kg / 5,29 lb  
32,5: 4,2 kg / 9,3 lb  
69: 4 kg / 8,8 lb

PACKAGING TYPE  
Brown box

PACKAGING MEASUREMENTS  
(H × W × D)

27  
30 cm × 28,5 cm × 28,5 cm /  
11,8" × 11,2" × 11,2"

32,5  
35,5 cm × 42,5 cm × 42,5 cm /  
14" × 16,2" × 16,2"

69  
71,5 cm × 35 cm × 33 cm /  
28,1" × 13,8" × 13"

MATERIALS & MAINTENANCE  
Please visit [audocph.com](http://audocph.com) for materials, care  
and maintenance instructions.

PLANTER, 27

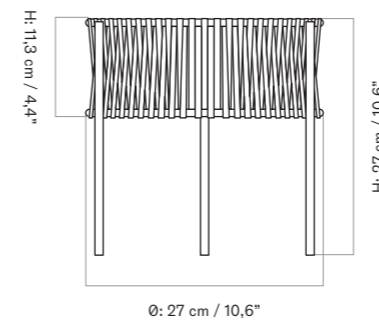

PLANTER, 32,5

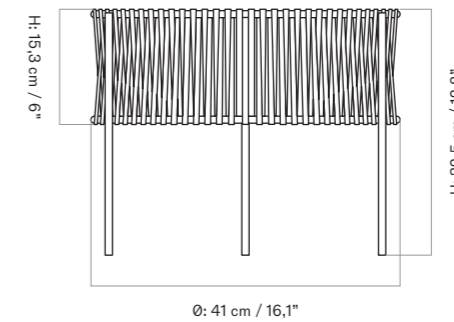

PLANTER, 69

