

# LED FLOOD LIGHT 100W

C&C Lighting Inc. Technical Data Sheet





### TECHNICAL SPECIFICATION

- By using the most powerful and efficient heatsink, the completed LED light can work up to 50,000 hours, saving up to 80% energy, with better lighting characteristics than traditional metal halide lamp of 10 to 200 watts
- Riveting the heat pipe to the heatsink, rapidly transfer the heat of the LED chips to the massive fins
- Aluminum alloy housing processed with anodization, solid in structure and withstand the corrosion
- Heatsinks of different sizes from 10 to 200 watts, according to varied lighting requirement
- Protection rate is IP65

### TECHNICAL SPECIFICATION

MODEL NUMBER	C&C-HLF-B100W
POWER	100W
LIGHT SOURCE	Phillips / Nichia 3030
LUMEN OUTPUT	130Lm/W
CCT	2700-7500K
HOUSING	Aluminum and Glass
OPERATION TEMPERATURE	-20~45°C
LIFESPAN	50,000hours
VOLTAGE RANGE	200-480V AC / 90-277V AC
FREQUENCY	50/60Hz
BEAM ANGLE	120°
CRI	>75
PF	≥0.95
POWER EFFICIENCY	≥0.90
WARRANTY	5years

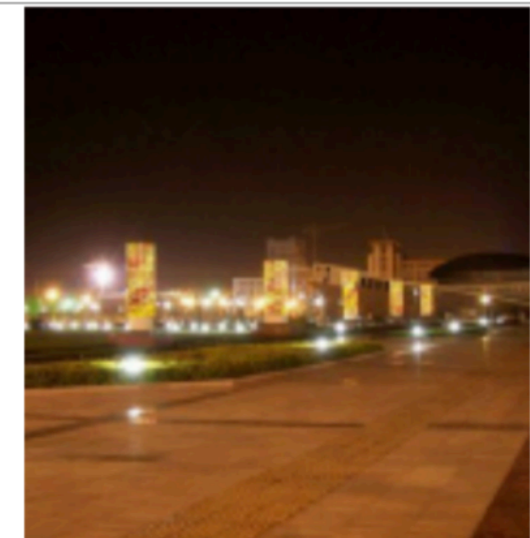

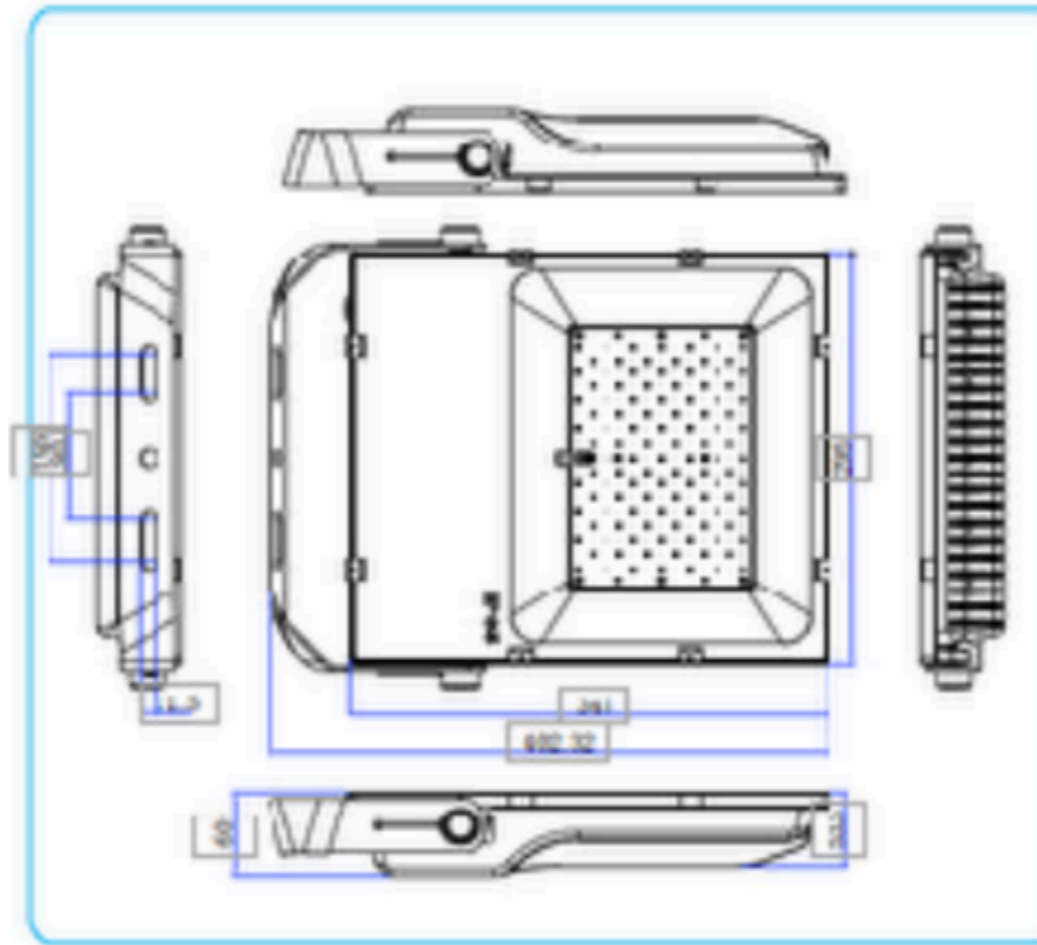
**DRAWING**

CARTONS	2pcs
NET WEIGHT	10.5kg
GROSS WEIGHT	12kg
SIZE OF INNER BOX	480x390x135mm
SIZE OF CARTON	500x415x310mm