



INSTALLATION & USER'S GUIDE

RadiusCX Clutch
for Hydraulic GasGas

Doc ID: 191-7907A
Revision: 040919

Table of Contents

OVERVIEW	3
INSTALLATION TIPS	3
TOOLS.....	4
INCLUDED PARTS	5
DISASSEMBLE CLUTCH.....	7
INSTALL THE HUB	12
INSTALL THE CLUTCH PACK	14
Notes for Clutch Pack Installation	14
INSTALL THE CLUTCH COVER	17
SLAVE CYLINDER INSTALLATION	18
BLEED THE CLUTCH LINE	27
SET THE INSTALLED GAP AND CHECK FREE PLAY GAIN	30
Step 1: Find the starting point	31
Step 2: Learn how to check Free Play Gain.....	32
Two Ways to Check for Free Play Gain	34
The Rubber Band Method	34
The Hand Method.....	36
Step 3: Break-in the new clutch	38
Step 4: Adjust the installed gap and Recheck Free Play Gain	40
FREE PLAY GAIN ADJUSTMENTS	41
LEVER SAFETY STRAPS.....	42
MAINTENANCE.....	42
Disk inspection examples.....	44
TROUBLESHOOTING.....	45
Performance issues.....	45
Clutch noise.....	45
EXP TUNING OPTIONS.....	45
Changing the springs	46
BUMP-STARTING	48
NEED ADDITIONAL HELP?	49

OVERVIEW

This kit replaces many of the OE (Original Equipment) or “stock” clutch parts. These parts are designed specifically for your motorcycle to ensure optimal performance. The following is a summary of what is replaced:

- This kit will replace all the OE friction disks and drive plates with a Rekluse thin friction EXP clutch pack.
- The OE pressure plate springs are replaced with high quality Rekluse springs.
- The OE center clutch hub and pressure plate components are replaced with Rekluse Core components.
- The OE basket can be re-used if tangs and dampers are in good condition





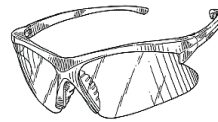





INSTALLATION TIPS

- Read the separate included Safety Information document before operating the vehicle with the product installed.
- Read this entire document before performing any steps.
- If you install this product for a customer or another person, instruct them to read the **Safety Information** document and the **Installation and User Guide** before operating the bike with the product.
- Protect eyes and skin – wear safety glasses and work gloves.
- Lay the motorcycle on its left side when replacing the clutch. This makes the clutch work easier and eliminates the need to drain the oil. Catch any fuel that may drain from the bike.



- Use the torque values listed in the instructions. Otherwise, use the torque specifications found in your OE service manual.
- For optimal clutch performance Rekluse recommends using fresh, clean oil that **meets JASO-MA** oil rating requirements. Rekluse offers Factory Formulated Oil™ developed specifically for Rekluse products. Rekluse Factory Formulated Oil is a perfect complement to any OEM or aftermarket wet clutch. Visit www.rekluse.com to learn more.

TOOLS

			
10 mm socket	8 mm socket	Metric Wrench	Torque Wrench
			
Pick	Fluid Catch Container	27mm socket	Channel lock pliers
			
Hammer	4 mm Hex key	5 mm Hex key	

INCLUDED PARTS

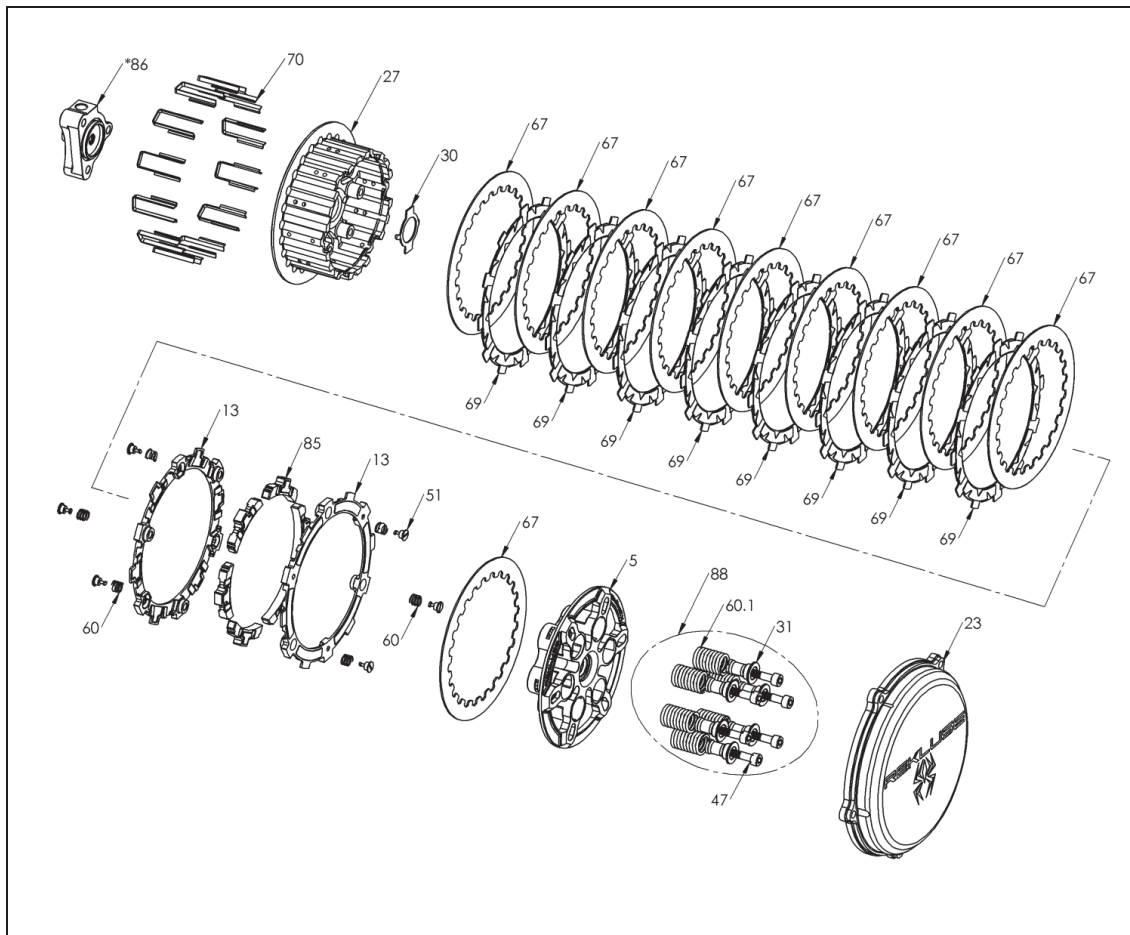

Item	Description	Qty.
5	Pressure plate	1
88	Clutch spring kit	1
60.1	Pressure plate springs	6
31	Screw sleeves	6
47	Pressure plate screws	6
23	Clutch cover	1
27	Center clutch hub	1
30	Tab lock washer	1
13	EXP base	2
51	Quarter turn pin (2 spare not shown)	8
67	Steel drive plates	10
69	TorqDrive® friction disks	8

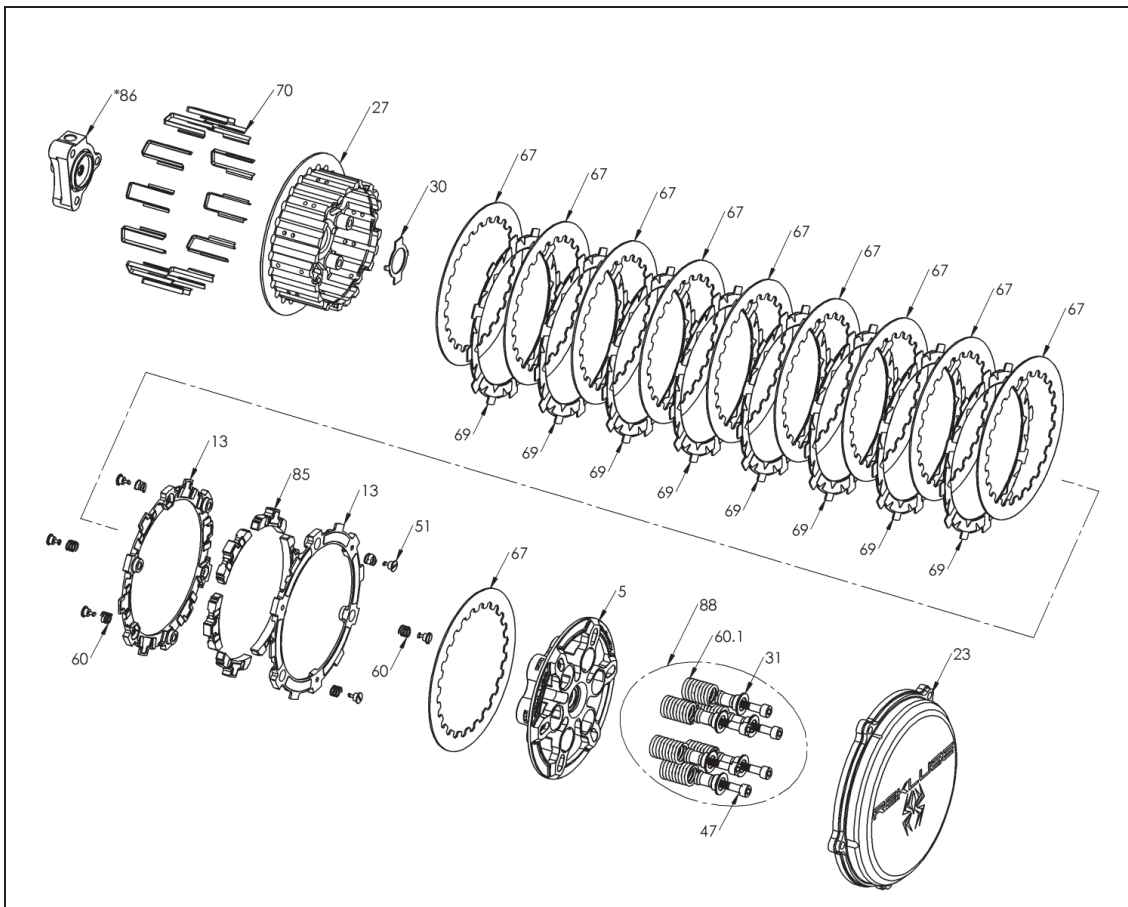

Item	Description	Qty.
85	EXP wedge assembly	6
60	EXP adjustment springs – Colors will vary. See Setup Sheet for tuning options	12
70	Basket sleeves	12
86	Adjustable slave cylinder assembly	1
Not shown	Clutch cover Viton O-ring cord	1
Not shown	Orange Free Play Gain rubber band	1
Not shown	Brake tip**	1

**Some models only

Visit www.rekluse.com/support for a full parts fiche illustration and part numbers.

DISASSEMBLE CLUTCH

1. If your bike is carbureted, turn the fuel petcock to “OFF.”
2. Shift the transmission into 5th gear.
3. Lay the bike on its left side. Catch any fuel that might drain in a suitable container.



For 2018 models and newer:

- Use a hex key to remove the brake pedal tip from the bike, then set it aside. The 2 OE screws will be reused.



4. Using an 8 mm socket, remove the OE clutch cover. Pay close attention to the length and location of the OE screws so they can each be returned to the same location.

- Using a socket, remove the pressure plate screws and springs, then remove the pressure plate.

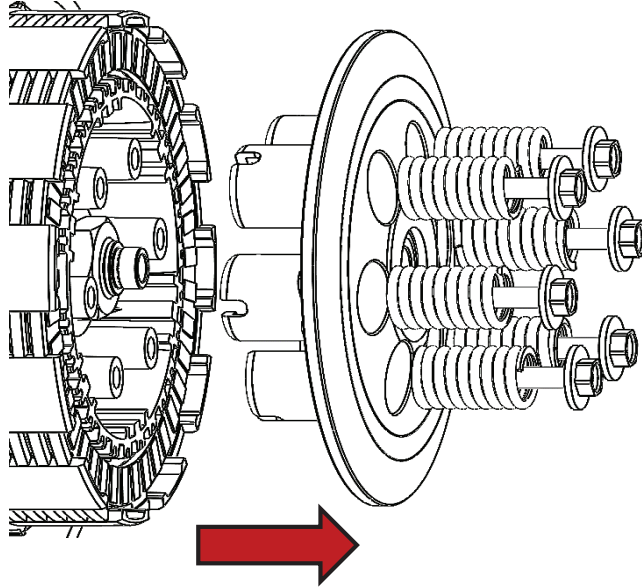

Note: Your OE parts may look different than pictured depending on the bike.

- Remove the OE clutch pack. Use a pick if necessary to help remove all of the plates.

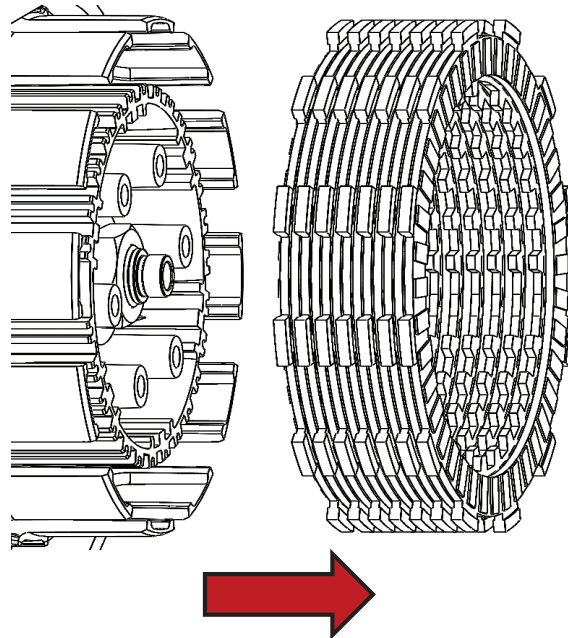

- Inspect the clutch basket for spring damper play or notching. Do not install sleeves or use product with a notched basket. Notched basket tang faces or worn

dampers can cause the sleeves to break. Do not use baskets that have been filed, machined, or modified on the tangs. Replace basket if necessary.

⚠ WARNING

Failure to inspect the basket and replace if necessary could result in death, serious injury, and/or property damage.

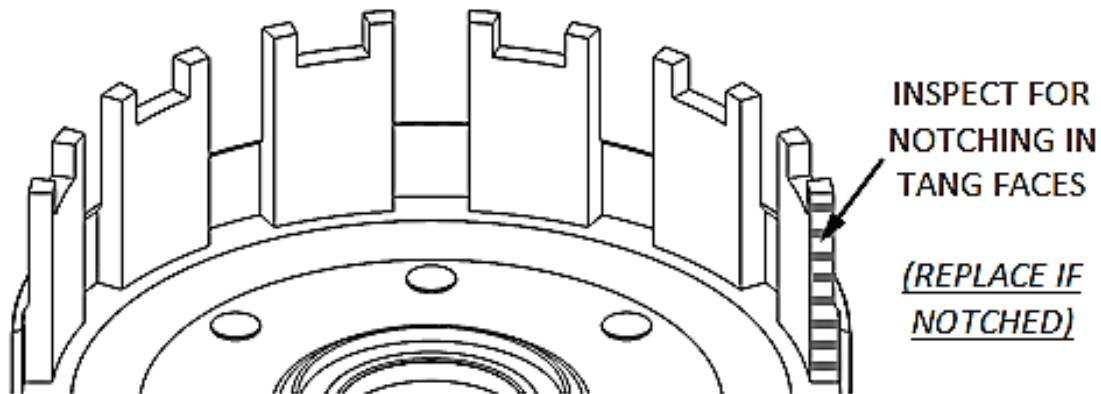

Note: Through extensive testing, Rekluse recommends replacing the OE clutch basket--even if the basket is in good condition. Billet Clutch Baskets are available from Rekluse and are specifically designed to ensure the longevity of the clutch. The part number is RMS-4100.



8. Remove the throw-out assembly, which typically includes a throw-out, needle bearing, and washer. Set this assembly aside. These parts will be reused.

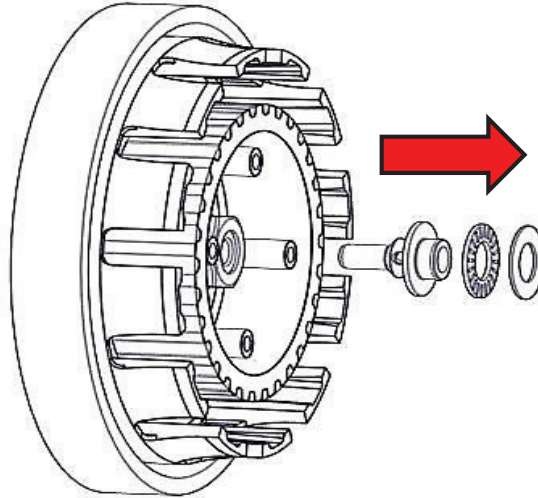

Note: *The throw-out assembly may look different depending on the bike.*

9. Use a hammer and large screwdriver to bend down the edges of the washer tab until it clears the clutch nut.

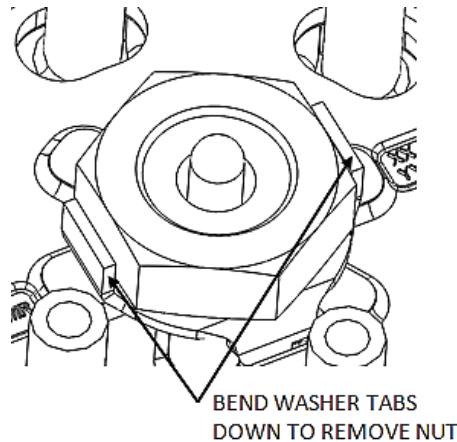

10. Remove the center clutch nut with an impact wrench or breaker bar, and a socket. Set aside. The OE clutch nut will be reused.

Note: *Placing the bike in the highest gear and holding the rear wheel by applying the rear brake keeps the shaft from rotating when removing the nut.*

11. Remove the lock washer located under the center clutch nut. The OE lock washer will be replaced with a Rekluse tab lock washer.

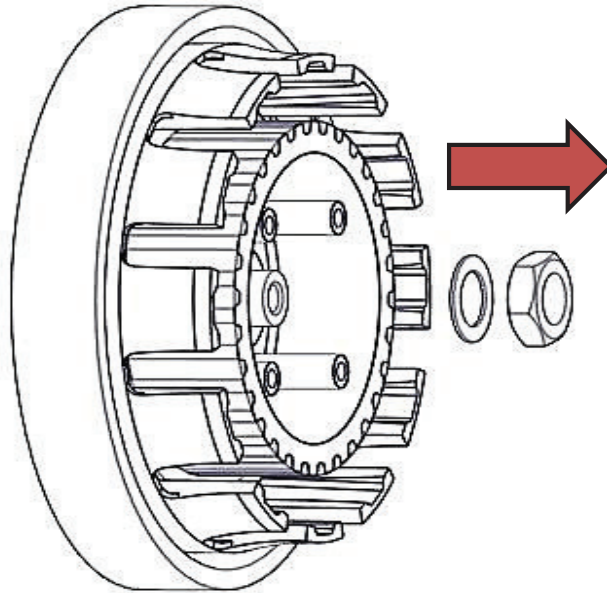

12. Remove the center hub from the clutch basket while leaving the thrust washer on the main shaft.

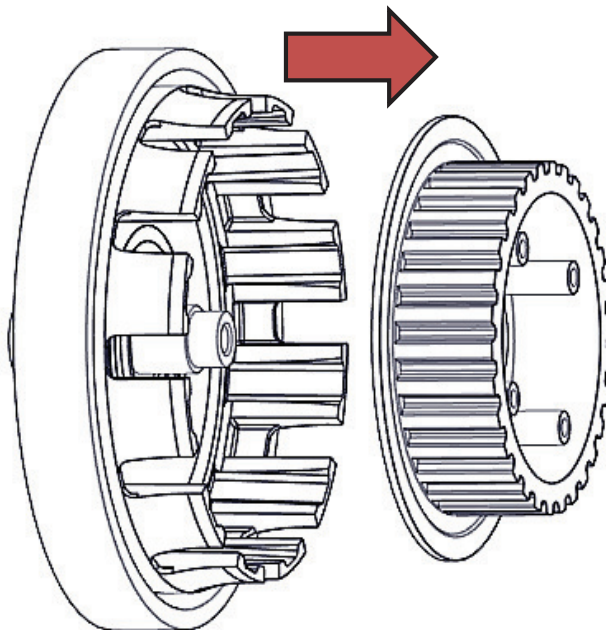

Note: Check that the OE thrust washer is still on the main shaft and not stuck to the bottom of the center hub assembly. The thrust washer must be installed or clutch performance issues will result.

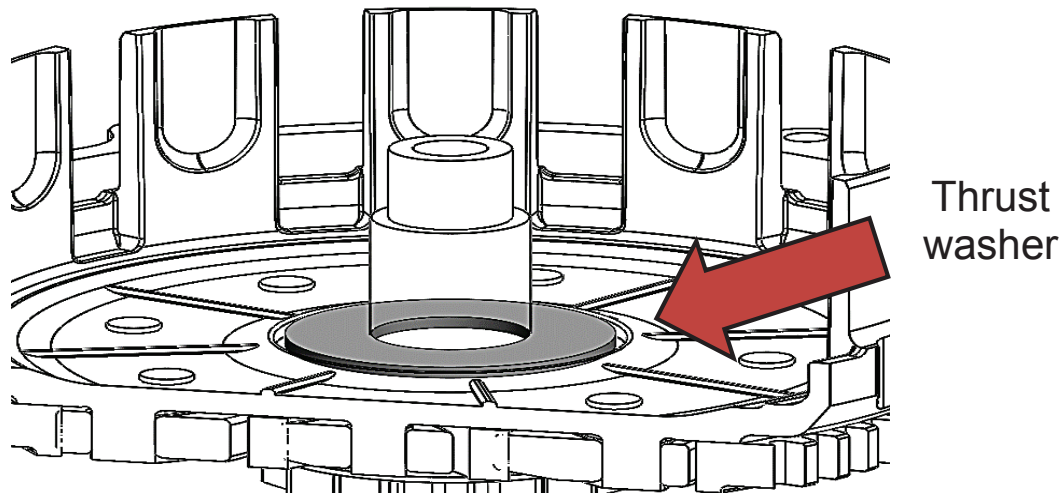

INSTALL THE HUB

1. Install the new Rekluse center hub into the clutch basket. Check to make sure the OE thrust washer is still on the main shaft before you install the hub.
2. Install the new Rekluse tab washer with the bent tabs facing down, aligning with the holes in the hub.

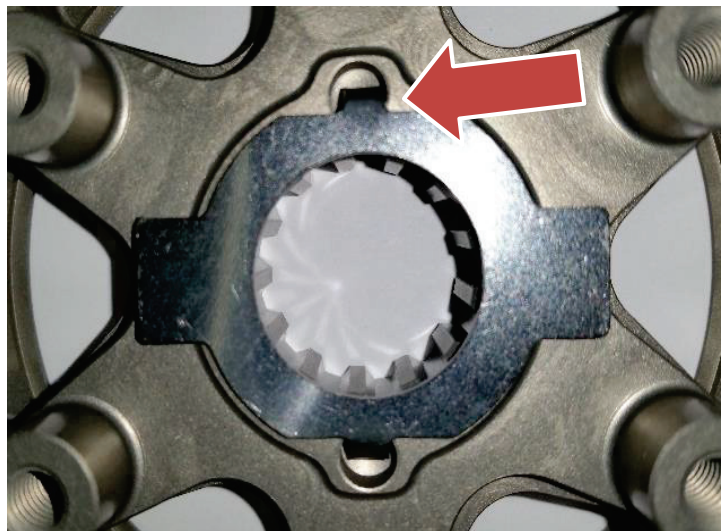

3. Install the OE clutch nut.

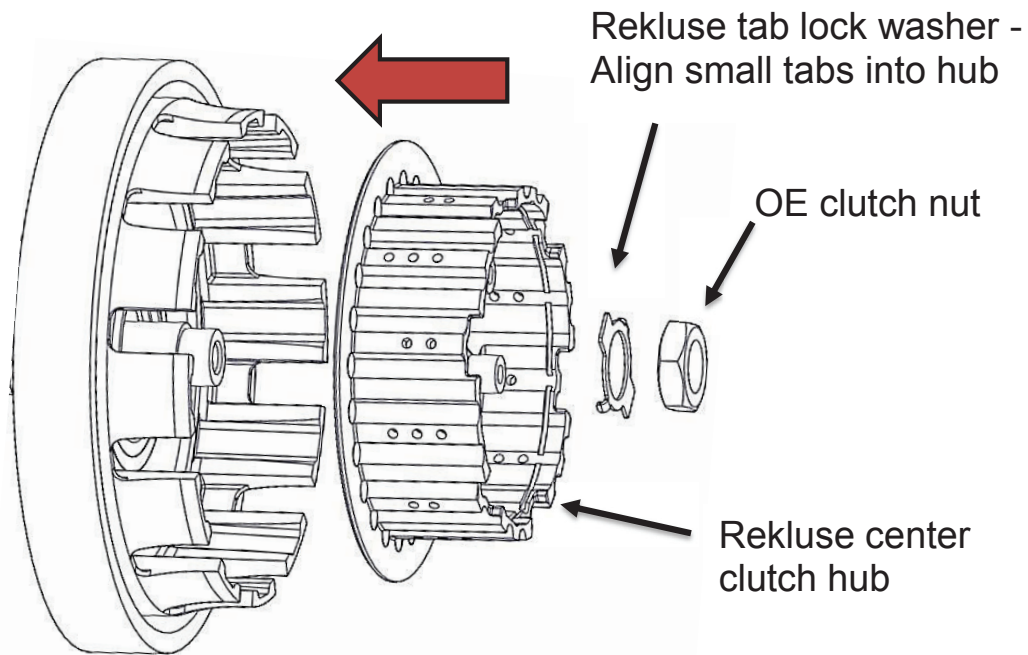

4. Using the socket and torque wrench, torque the center clutch nut to **50 ft-lb (68 N-m)**.

5. Using the channel-lock pliers, bend up **both** tabs of the tab washer tightly around the nut. The tabs can be bent on the straight sides or around the corners.

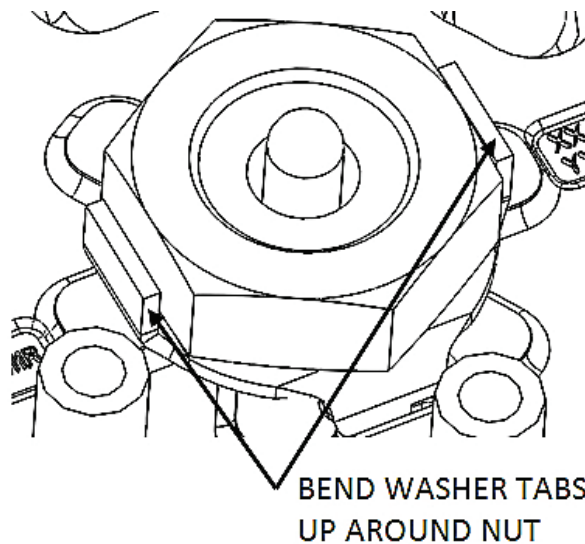

INSTALL THE CLUTCH PACK

Notes for Clutch Pack Installation

- *The order of the clutch pack, the clutch pack measurements, and EXP tuning information can be found on the **Setup Sheet**.*
 - *Some friction disks are marked with a small colored dot. This mark is used for processing and can be ignored.*
1. Soak the EXP disk and friction disks in new engine oil for 5 minutes. Make sure the EXP and friction disks are coated in oil on both sides.
 2. Install all the Rekluse basket sleeves into the basket slots. Make sure the bottom of the sleeve is facing down, and the sleeve tabs sit against the inside of the basket. See pictures for reference.

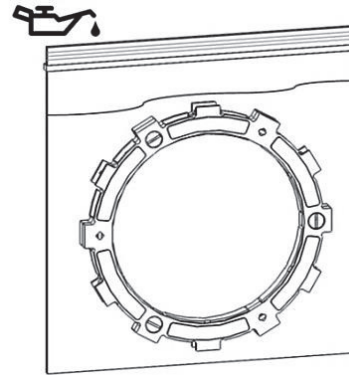

Note: When seated in the basket, the sleeves may stick above or below flush with the top of the basket depending on the bike model. This is normal.

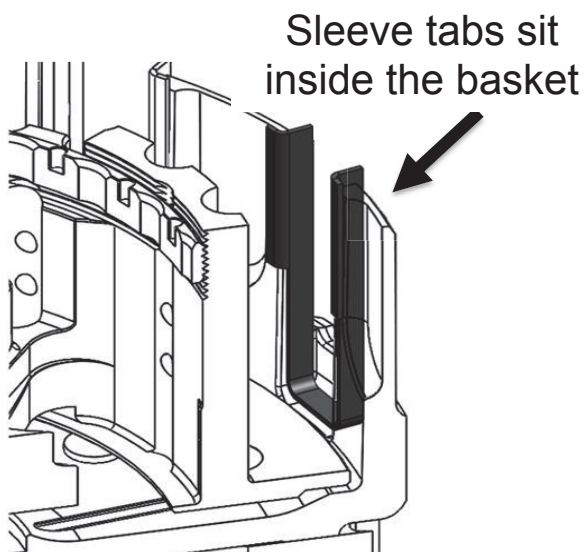

Insert all the basket sleeves

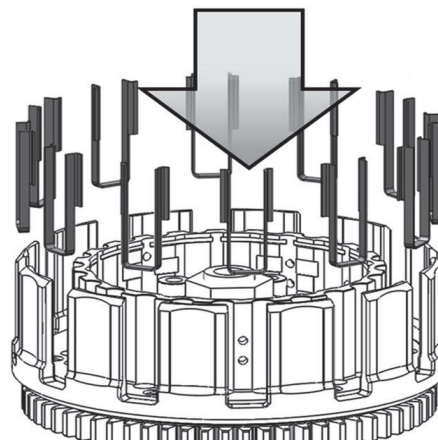

3. Install one steel drive plate into the clutch basket first, indexing the teeth to the center hub.
4. On top of the steel drive plate, alternate friction disks and steel drive plates for the entire Rekluse clutch pack based on the Setup Sheet **except for the EXP disk and 1 steel drive plate which will go in last.**

Note: *If the basket sleeves fall forward while installing the clutch pack, use a pick to push the basket sleeves back into place.*

5. Install the EXP disk, then install the last steel drive plate.

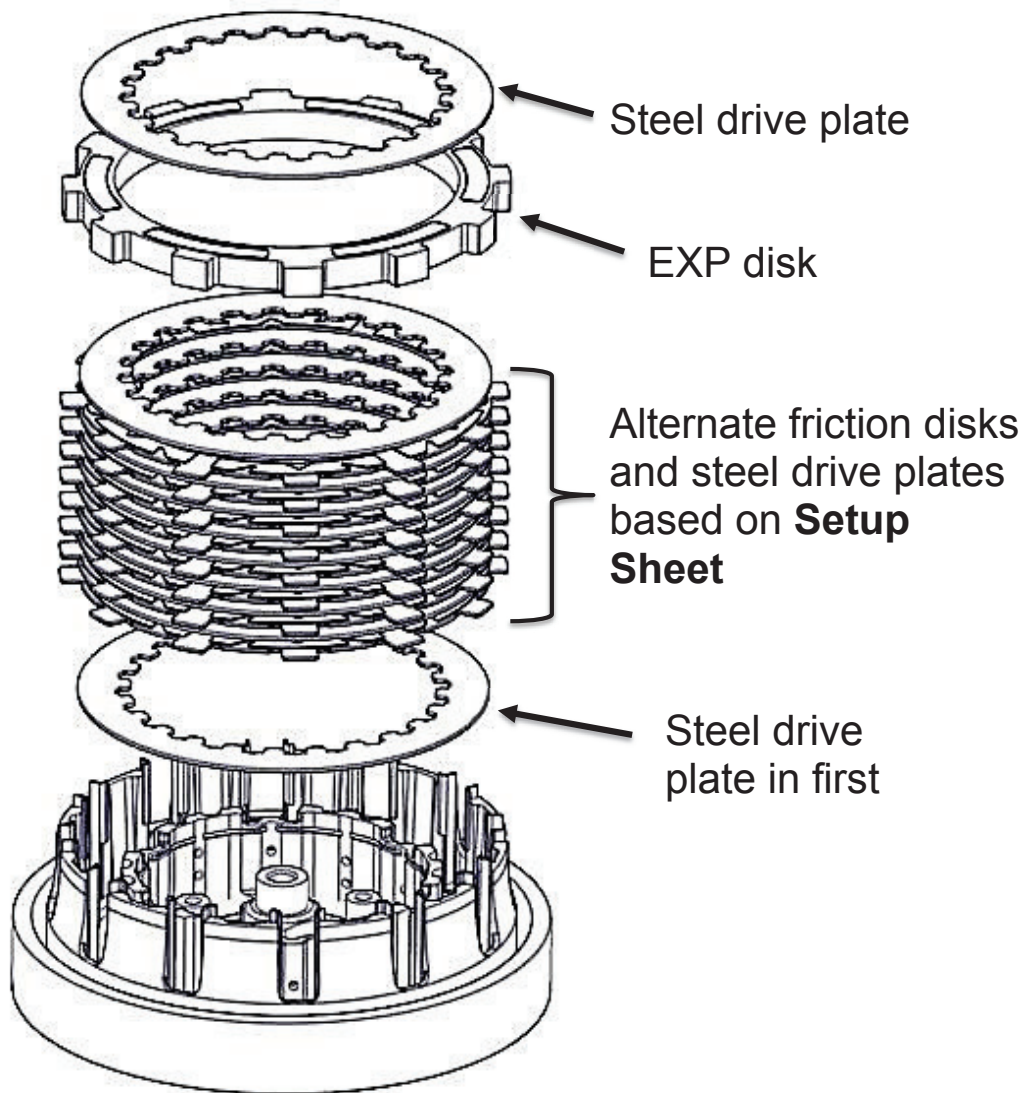

6. Reinstall the OE throw-out assembly. If the throw-out washer is missing, check to see if it is stuck to the underside of the pressure plate.

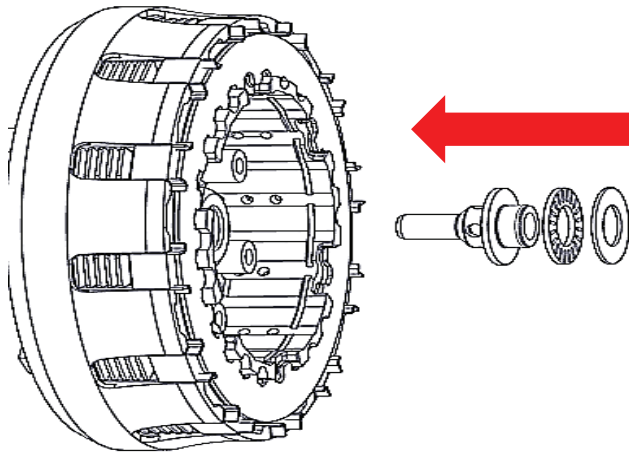

Core EXP Upgrade Note:

- If you are upgrading your clutch from Core EXP, you **MUST** use your OE throw-out, bearing, and washer. The Rekluse throw-out that came with the Core EXP kit will not work with the new RadiusCX clutch pack.

7. Reinstall the pressure plate.

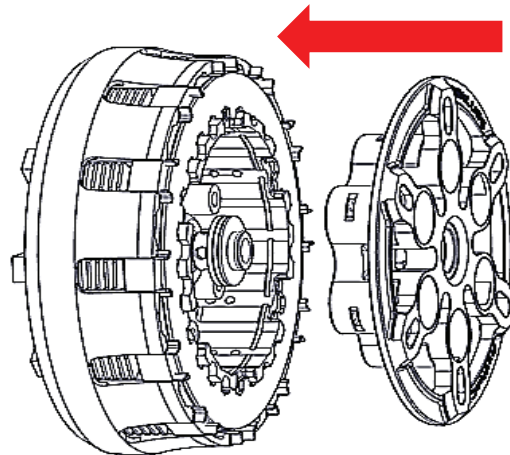

8. Install the Rekluse pressure plate springs, then insert the screw sleeves. Insert the Rekluse pressure plate bolts into the screw sleeves.

⚠ CAUTION

Do not reuse the OE springs or bolts. They will cause interference with the clutch cover!

Note: *Be sure to alternate springs if you are using two different color springs to keep even pressure on the clutch.*

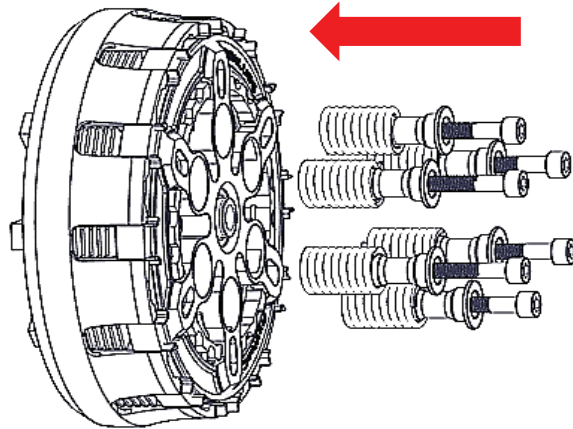

9. Using a torque wrench, tighten the pressure plate bolts to **9 ft-lb (12 N-m)**.

INSTALL THE CLUTCH COVER

1. Place the Rekluse clutch cover onto the bike, then reinstall the OE bolts into the clutch cover. Be sure to return the bolts in the same location they were removed.

⚠ CAUTION

Failure to install the OE clutch cover bolts back in their proper location can result in damage to your motorcycle.

For 2018 models and newer:

Your clutch kit comes with a new brake tip. This new tip ensures the brake pedal has enough clearance from the clutch cover.

- a. Install the Rekluse brake tip instead of the OE brake tip.

- b. Use the OE screws to attach the tip onto the brake arm.
- c. Readjust the brake pedal once installed.

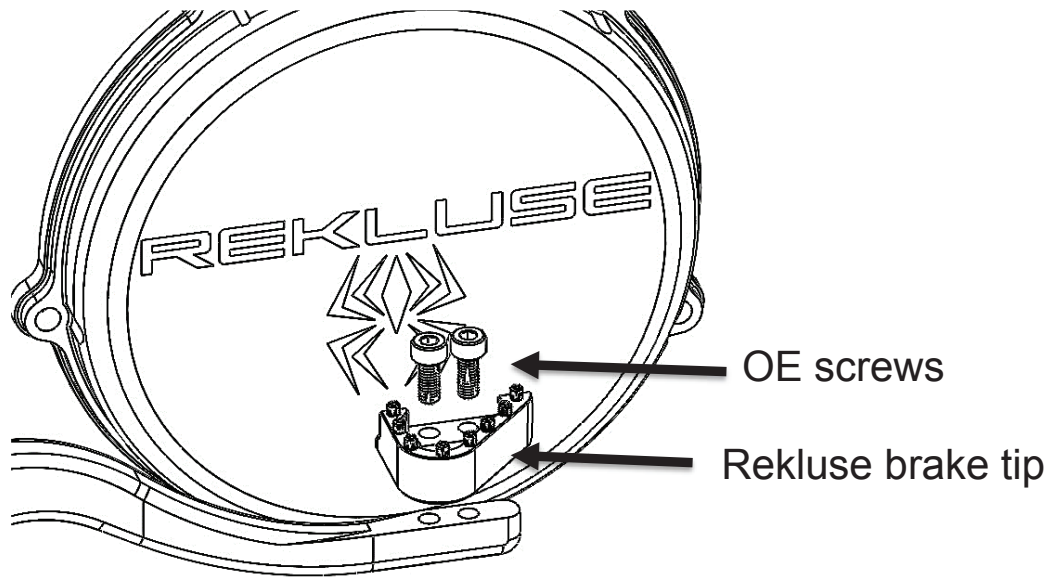

SLAVE CYLINDER INSTALLATION

Installing the new Rekluse slave cylinder takes several steps. Please read the entire section before beginning the process to ensure you have the right equipment and clutch fluid needed for the replacement. Rekluse recommends wearing gloves and safety glasses for the install.

⚠ CAUTION

During the bleed and assembly, note that there is a small ball bearing installed in the slave piston with a small amount of grease. When installing the Rekluse slave cylinder, make sure the ball is in place and has not come loose.

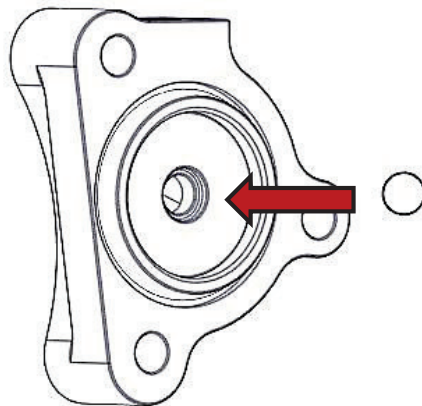

Step 1: Bleed the new slave cylinder

This step prepares the new slave cylinder for installation. Bleed the cylinder on a workbench or an area away from the bike.

- a. Using a 4 mm Allen wrench, turn the adjuster screw **counterclockwise** so that the top O-ring is visible under the adjuster screw.

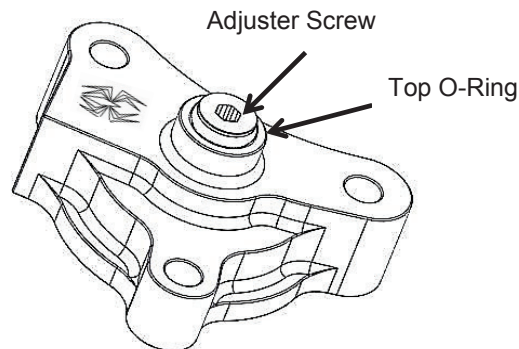

- b. Use your thumbs to compress the piston until it bottoms out, then release it.
- c. Pour the manufacturer recommended clutch fluid into the slave cylinder port.

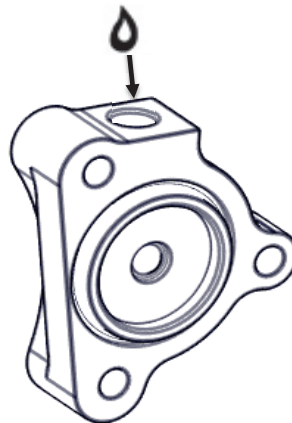

CAUTION

Be sure to use the correct clutch fluid. Check the cap of the clutch master cylinder to determine which clutch fluid to use. Failure to use the correct fluid will result in seal damage and/or failure.

- d. Use a 4 mm Allen wrench to turn the adjuster screw **clockwise** until it bottoms out and the O-ring is no longer visible. Keep the fluid topped off as you go.

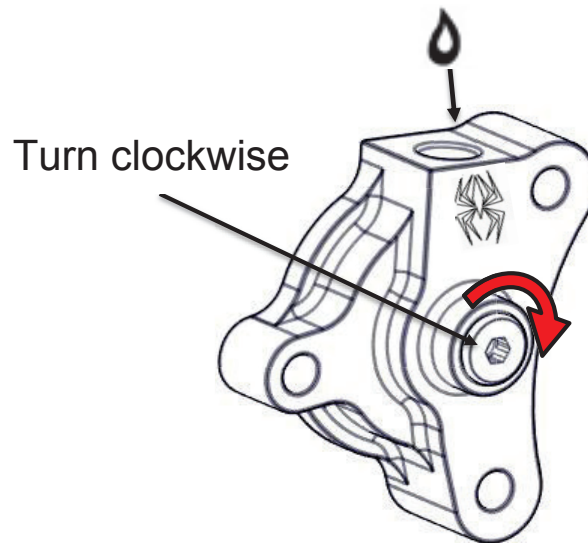

- e. Use the wrench to turn the adjuster screw **counterclockwise** back to the initial position, with the top O-ring visible. Keep the fluid topped off as you go.

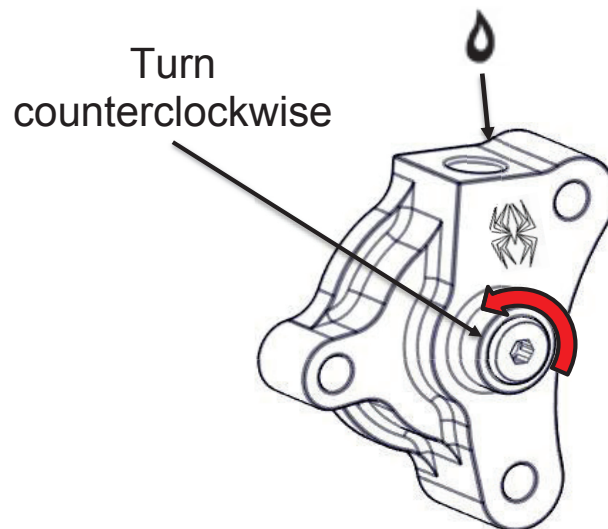

- f. Use your thumbs to compress the piston again until it bottoms out while looking for air bubbles.

⚠ CAUTION

When compressing the piston, fluid can shoot out from the slave cylinder port. Be sure to wear eye protection.

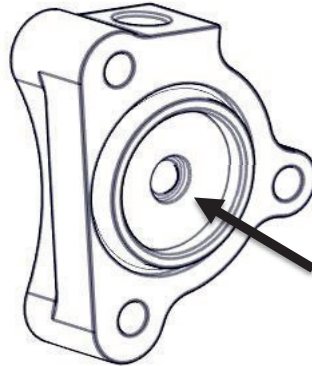

- g. Repeat steps d-f until there are no air bubbles coming out in the fluid when the piston is compressed.
- h. When the bleeding is complete, turn the adjuster screw counterclockwise so that the top O-ring is visible.
- i. Compress the piston until it bottoms out, and top off with fluid.
- j. Check that the ball bearing is still in place. Stand the Rekluse slave cylinder in an upright position (so the fluid does not spill) until it is needed in the next step.

Note: Some models have a piston diaphragm seal. **DO NOT** reuse them if OE equipped. The Rekluse slave cylinder does not require a diaphragm seal.

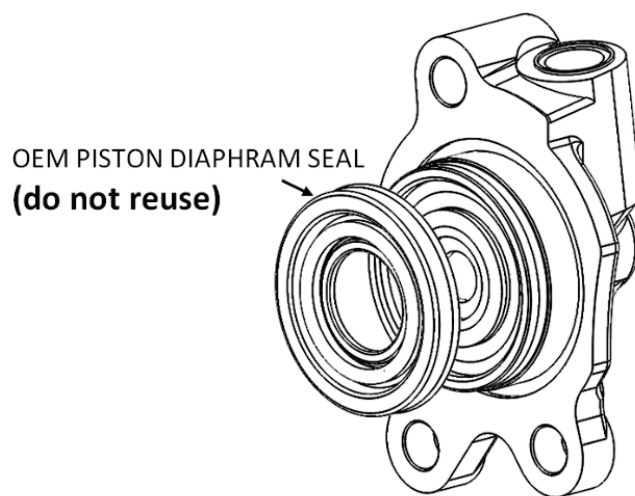

Step 2: Replace OE slave cylinder

In this step, the OE slave cylinder is replaced with the Rekluse slave cylinder. Work quickly when performing the following steps. This method retains the fluid inside the line, and makes the final bleeding step easier.

- a. Stand the bike up and lean it on its kickstand, or place it on a suitable bike stand.
- b. On the left side of the bike, while leaving the OE slave cylinder intact on the engine, use a wrench to remove the banjo bolt from the OE slave cylinder.
- c. Remove the clutch fluid line and the 2 OE crush washers from the OE slave cylinder. Discard the used crush washers.

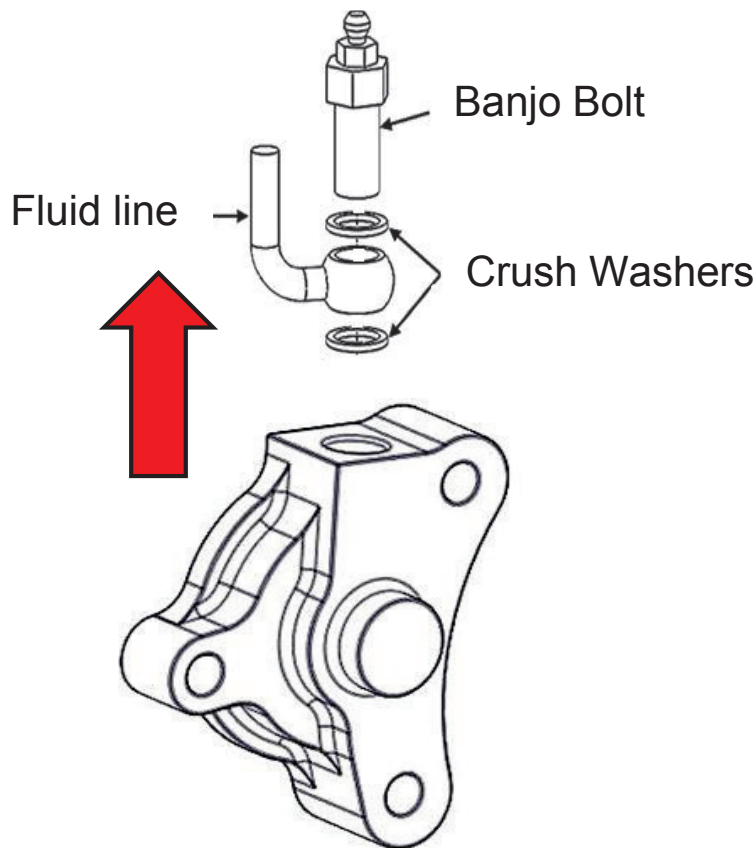

d. Attach the clutch fluid line to the Rekluse slave cylinder using the OE banjo bolt and the 2 new crush washers from Rekluse. Make sure the clutch fluid line is between the 2 crush washers.

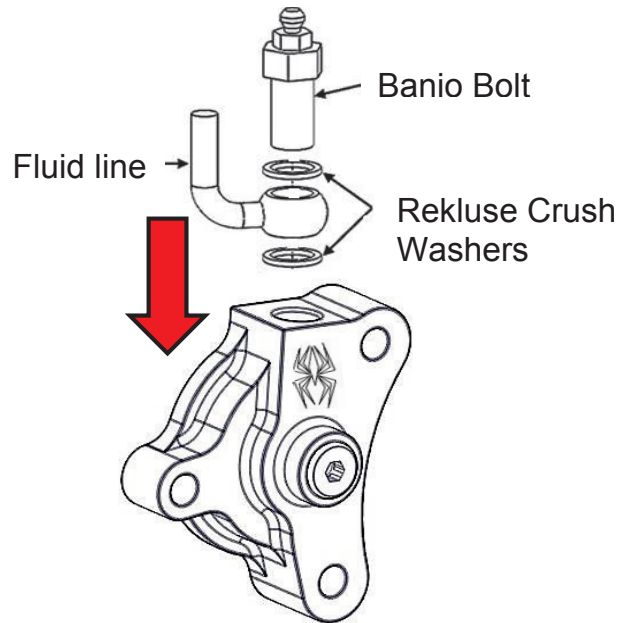

- e. Tighten the banjo bolt with your hand until snug. (You will tighten it once installed on the bike.)
- f. With the clutch fluid line attached to the Rekluse slave cylinder, remove the OE slave cylinder from the engine. Keep the OE bolts for reuse.
- g. Loosely mount the Rekluse slave cylinder to the engine by installing 1 OE bolt on the left side of the slave cylinder.

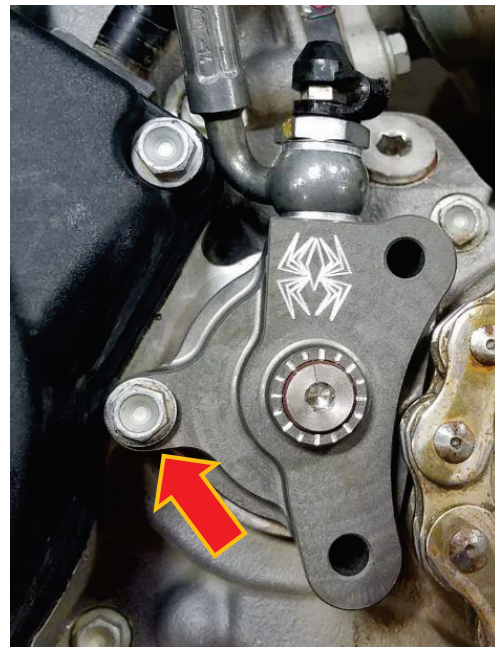

Slave Cylinder Notes

Depending on your bike model-year, your Rekluse Adjustable Slave Cylinder assembly includes either a replacement steel case saver or an aluminum spacer. These parts provide adequate clearance to the plastic chain guard while allowing access to the adjuster screw on the Rekluse slave cylinder housing.

2000-2017 Models

- Replace the OE case saver with the Rekluse case saver before reinstalling the chain guard.

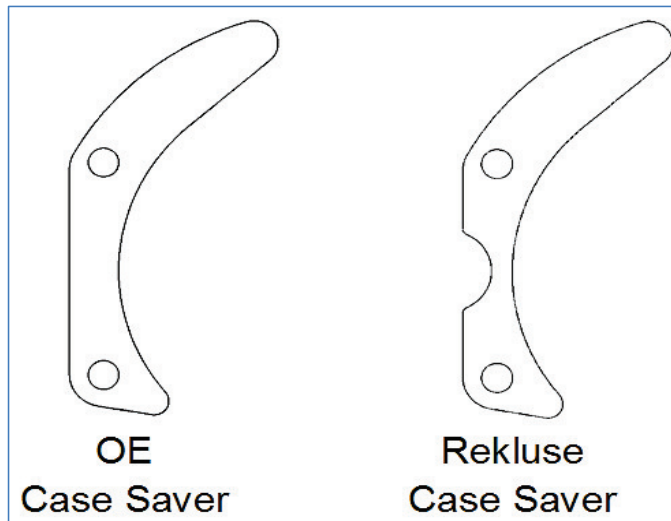
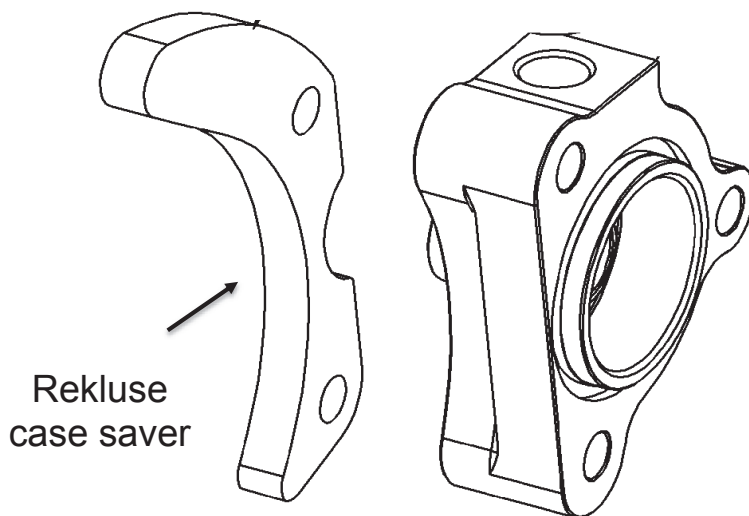

2018 and newer models

- a. Using the spacer as a template, turn the case saver over, then use a cutting tool to remove a small section from the back edge of the plastic chain guard. Cut 1/8" (3.1 mm) deep to fit over the adjustment screw.

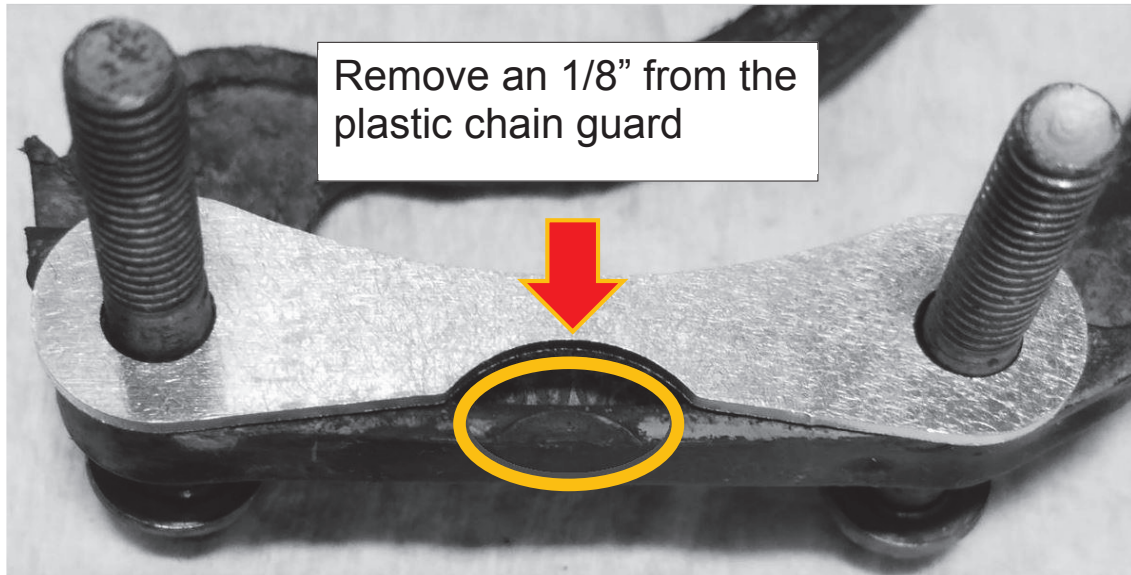

- b. Next, install the Rekluse aluminum spacer between the slave cylinder housing and the plastic chain guard.

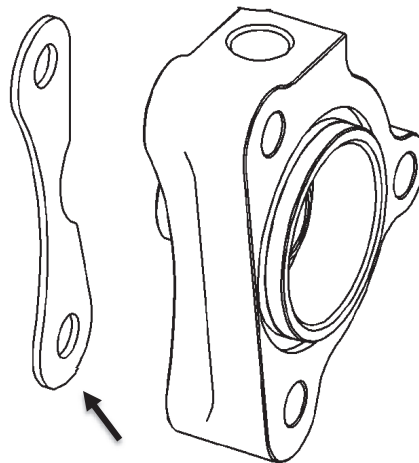

Rekluse Spacer

Finish installing the Slave Cylinder

1. After installing the Rekluse case saver or chain guard spacer, reinstall the chain guard.
2. Install the 2 remaining OE bolts on the right side of the slave cylinder.

2000-2017 models

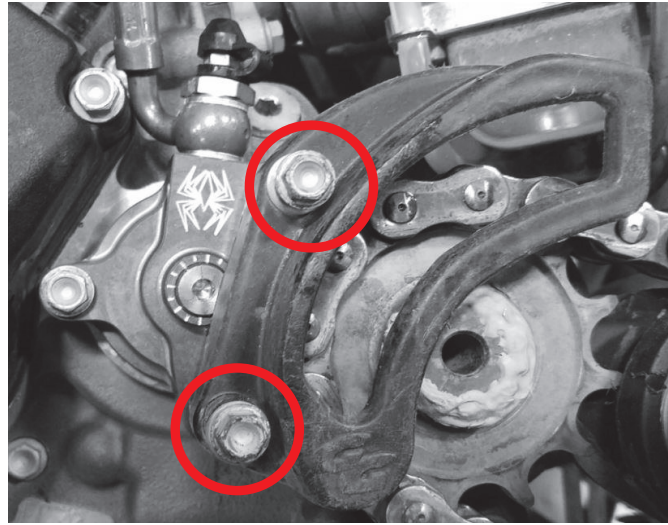
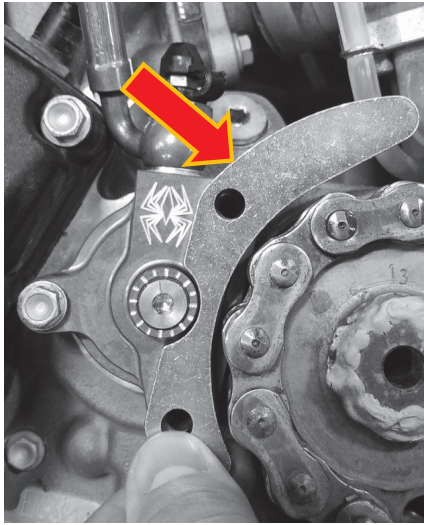

2018 or newer models

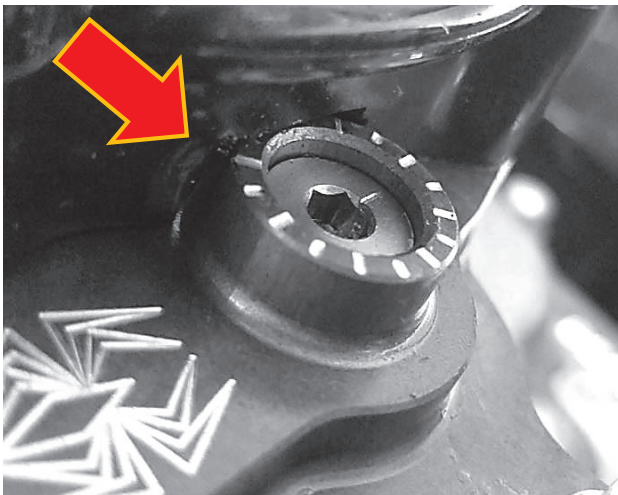

Notch cut in plastic
chain guard

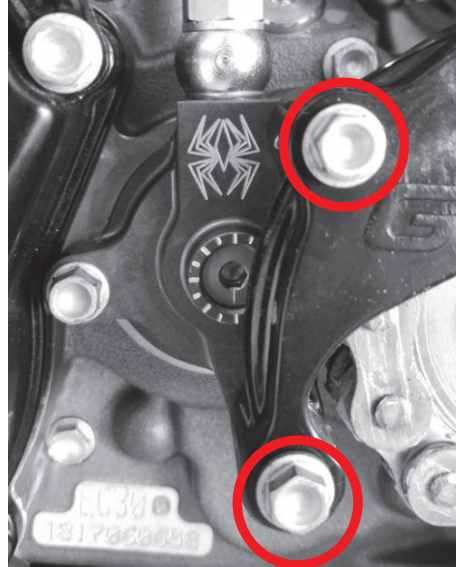

3. Tighten all the slave cylinder screws to OE specifications.
4. Torque the banjo bolt to **18 ft-lb (25 N-m)** per OE specification.

BLEED THE CLUTCH LINE

1. Attach one end of the supplied bleed tube to the banjo bolt port, then loop the opposite end into a suitable catch bottle.

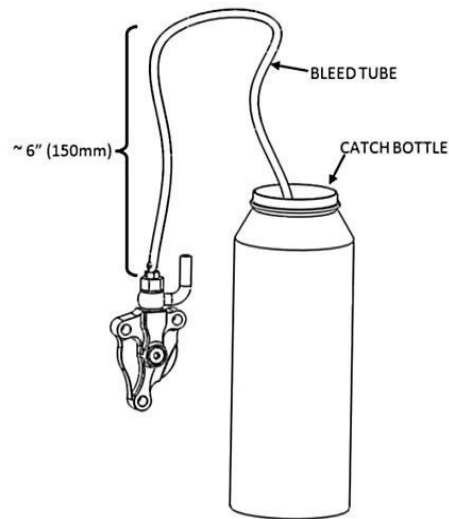

2. On the handlebar, remove the cap and bladder from the clutch master cylinder. Adjust the reservoir so it is level with the ground.

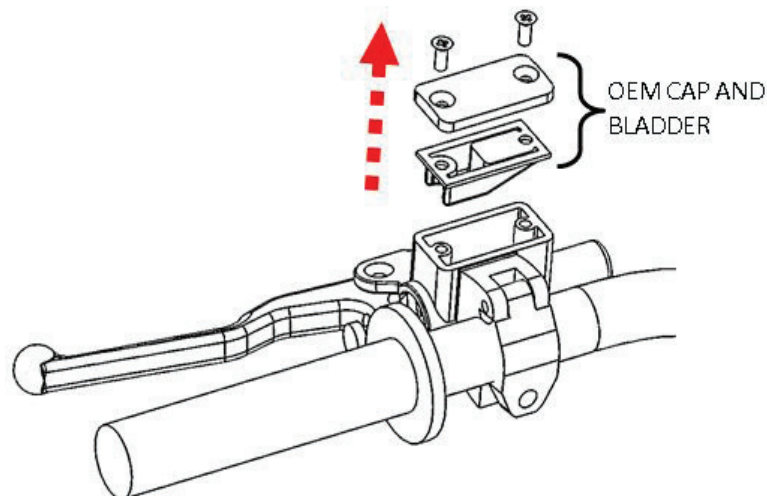

3. Top off the master cylinder with the recommended clutch fluid until it is 75% full.
4. Pump the clutch lever 3 to 5 times, then hold it against the handlebar/grip.

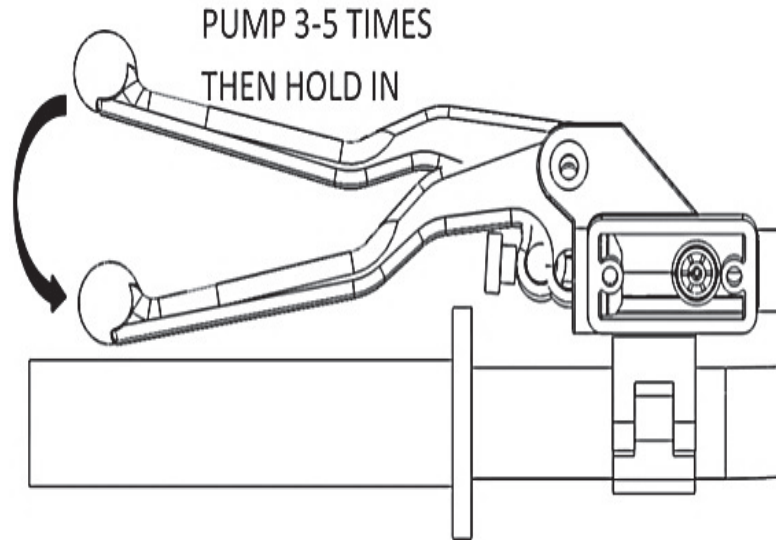

5. While still holding the clutch lever in, use a wrench to open the bleed port. Air and fluid should flow from the bleed tube.
6. Before releasing the clutch lever, tighten the bleed port when the pressure is released from the bleed tube.
7. Slowly release the clutch lever and check the fluid level in the clutch master cylinder. Top off if necessary.

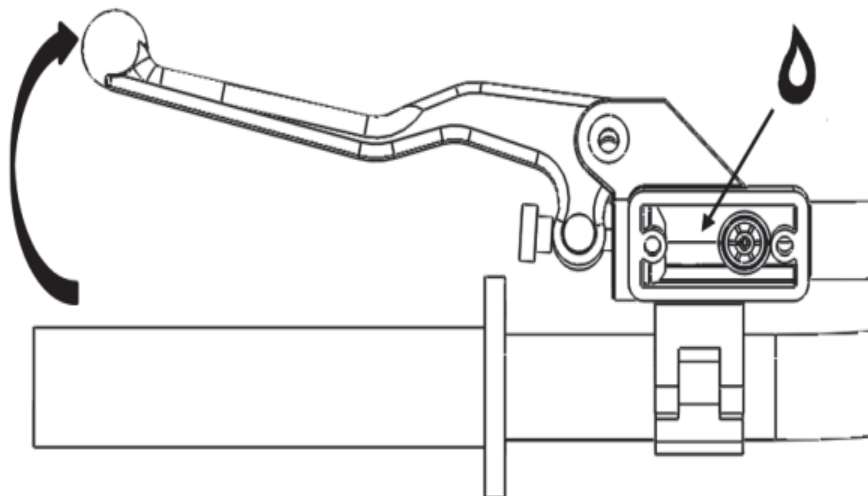

8. Repeat steps 4 - 7 until air no longer comes out of the bleed tube and the clutch feels normal.
9. Check that the clutch master cylinder is 75% full, then replace the cap and bladder.

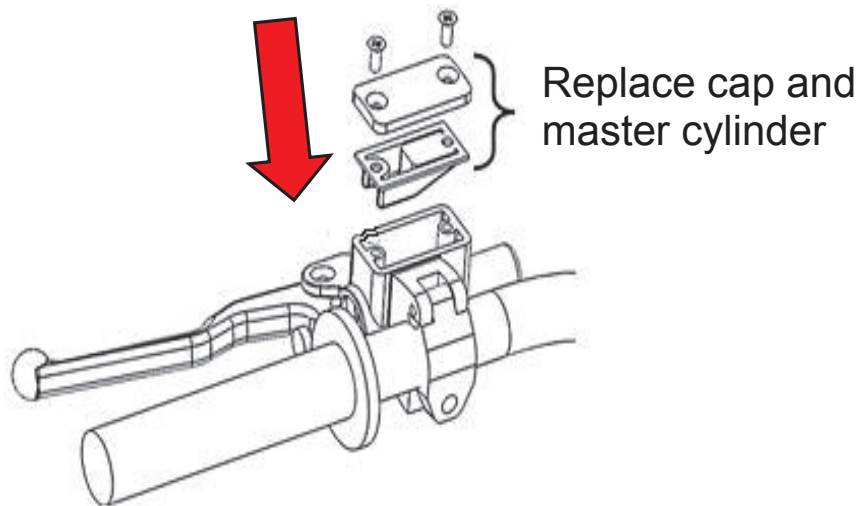

10. Remove the bleed tube from the bleed bolt and remove the bottle.
11. Torque the bleed screw to **150 in-lb (17 Nm)** with a socket or the closed end of an 8 mm wrench.

Note: *Be sure to use a socket or closed end wrench when torqueing the bleed screw. Using an open-ended wrench can strip the hex screw.*

SET THE INSTALLED GAP AND CHECK FREE PLAY GAIN

It is very important that you understand how to set the installed gap in your new clutch, and be able to verify the installed gap by checking Free Play Gain.

Setup, break-in, and rechecking the installed gap is CRUCIAL. Failure to properly maintain your installed gap can result in premature wear or failure of your clutch.

The “installed gap” is the free space in the clutch pack when the EXP disk is disengaged (collapsed). This gap allows the clutch to spin freely until the engagement RPM is reached and the EXP disk expands to close the gap and apply pressure to the pressure plate, which in turn drives the motorcycle forward.

The installed gap is what allows the auto function of the product to perform properly. Use the following steps to set the installed gap and check the Free Play Gain.

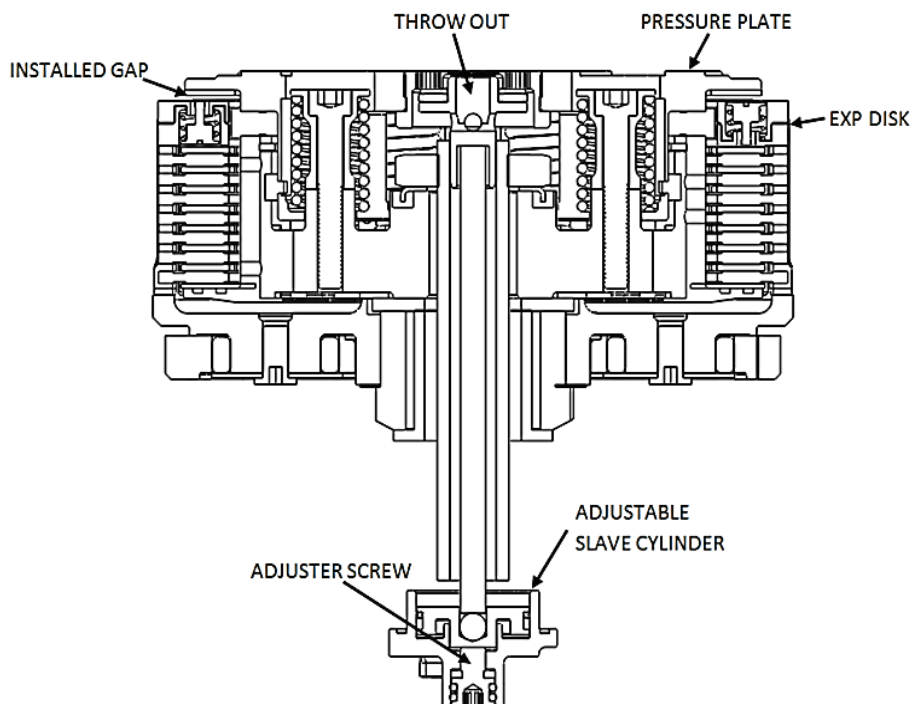

⚠ WARNING

Failure to check and verify Free Play Gain can cause failure or damage to this product. Setting the correct installed gap is critical for clutch performance.

Setting the installed gap and checking Free Play Gain is a 4-step process. It is important to follow each step to ensure that your new clutch functions as designed.

Step 1: Find the starting point

- a) With the bike standing up, locate the adjuster screw in the center of the adjustable slave cylinder.
- b) With the O-ring showing, use a 4 mm Allen wrench to turn the adjuster screw clockwise until it stops under light pressure. This is your “starting point.”

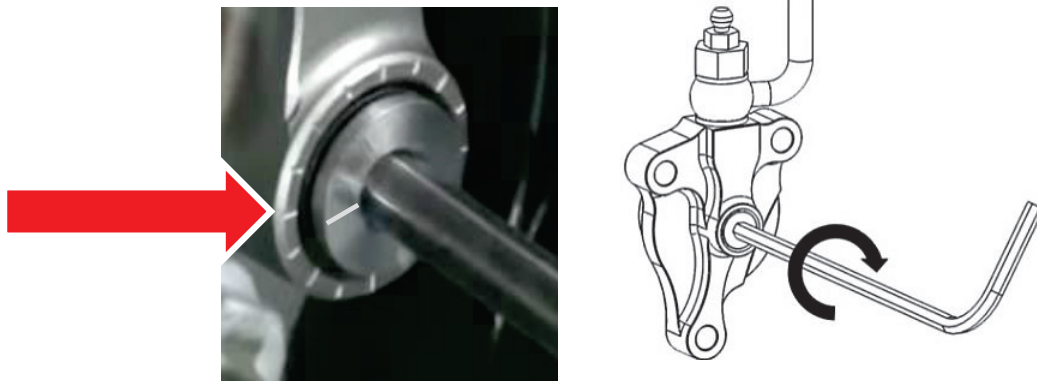

Note: *The resistance you feel is where the throw-out begins to lift the pressure plate. Finding the right starting point may take a few tries, but you will feel a noticeable change in turning effort once you reach that point. Stop when you feel the pressure increase. The “starting point” will change as the clutch pack wears over time.*

- d) Once you have found the starting point, note the position of the Allen wrench using the tick marks on the slave cylinder housing and the small etch mark located on the screw. You will begin here to adjust the installed gap.



Use the tick marks on the cylinder and the etch mark on the screw to remember the starting point for adjusting the gap.

- e) Use a 4 mm Allen wrench to turn the adjuster screw clockwise 1 full turn + 2 tick marks from your starting point. This may NOT be your final setting, but it is a beginning adjustment for finding the correct setting.
- f) Continue with Step 2 to check for Free Play Gain.

⚠ CAUTION

Do not ride your bike without the adjusting the installed gap. You will not be able to disengage the clutch until you set the installed gap.

Step 2: Learn how to check Free Play Gain

Feeling Free Play Gain with the beginning adjustment to the slave cylinder aids in learning to recognize Free Play Gain.

If you are familiar with Free Play Gain, check for Free Play Gain then skip to Step 3 - "Break-in the new clutch."

If Free Play Gain is new to you, follow the instructions below to help you learn this important step. You can also view the video entitled "How to Check Free Play Gain" on our website at www.rekluse.com/support/videos.

Free Play Gain is different from the “normal” free play (slack) you are used to with your stock clutch. With the Rekluse auto clutch, Free Play Gain is the result of the EXP disk expanding and lifting the pressure plate to engage the clutch.

Free Play Gain happens when the engine’s RPM increases from idle to above approximately 5,000 RPM and the EXP closes the installed gap. The amount of Free Play Gain you feel in the lever corresponds to the amount the pressure plate has been lifted by the EXP disk expansion.

Checking Free Play Gain allows you to externally monitor the installed gap so you can know when to make an adjustment if the installed gap is too large or too small.

The correct installed gap is verified by observing and feeling the increased free play movement in the clutch lever. This extra movement is called “Free Play Gain.”

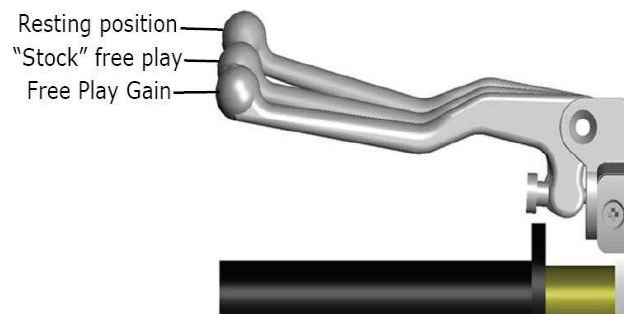
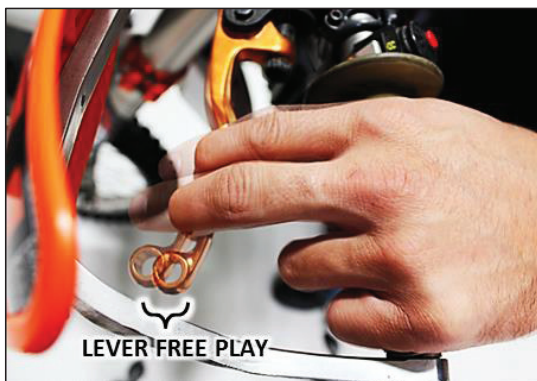

If there is too much Free Play Gain, the installed gap is too small.

- The bike may drag and stall because it has difficulty disengaging the clutch.
- It may also be difficult to shift.
- Too much Free Play Gain will not hurt the clutch, but it will negatively affect clutch performance.

With too little or no Free Play Gain, the installed gap is too large. This means when the EXP is fully expanded it does not lift the pressure plate.

- The clutch may slip and make the bike seem like it is losing power.
- The bike may not move forward even though the engine RPM increases as if the clutch lever is slightly pulled.
- Too little Free Play Gain will cause the clutch system to burn up.

Optimal Free Play Gain yields 1/8" to 1/4" (3 mm-6 mm) of clutch lever movement, measured at the ball end of the lever. This measurement at the lever correlates to achieving the ideal installed gap.

Two Ways to Check for Free Play Gain

The following steps explain **2 ways** to check Free Play Gain. One way uses the rubber band Rekluse includes in the clutch kit, and one uses your hand. You can use either method to check for Free Play Gain.

Rekluse recommends that you begin with the rubber band method first to check for Free Play Gain and then learn the hand method. The rubber band will help you learn how to recognize Free Play Gain until you are comfortable with the hand method. Learning to check Free Play Gain by hand effectively and comfortably can make it easy to check Free Play Gain every time you ride.

The Rubber Band Method

Use the rubber band method for the initial set up. It can also be used before each ride until you feel comfortable checking the Free Play Gain using the hand method.

⚠ WARNING

BEFORE YOU BEGIN, verify that the bike is in NEUTRAL before checking Free Play Gain. Failure to do so may result in the bike lurching forward, and loss of control and/or injury may result.

A Rekluse auto-clutch can make your motorcycle appear to be in neutral when in gear, even when the engine is running and clutch lever released.

Motorcycles equipped with a Rekluse auto-clutch can move suddenly and unexpectedly and cause riders to lose control. To avoid death, serious injury, and/or property damage, always sit on the motorcycle to start it.

- a) Before you begin, place the bike in **NEUTRAL**, start the engine and let it warm up for 2-3 minutes to idle down and warm the engine oil.

- b) Stretch the included rubber band between your thumbs, then place the top end of the rubber band on the outer end of the left handlebar grip.



- c) While holding the top end of the rubber band against the handlebar, stretch the band downward, then loop it through itself.



- d) Pull the band through the loop, then attach it to the outside end of the clutch lever. This will take up the initial free play (slack) and put the lever in a position to detect the Free Play Gain.



- e) While still in **NEUTRAL**, quickly rev the engine between 5,000-7,000 RPM (1/2 to 3/4 throttle), then let it return to idle. Notice the movement in the clutch lever when the engine is revved. This is your Free Play Gain.

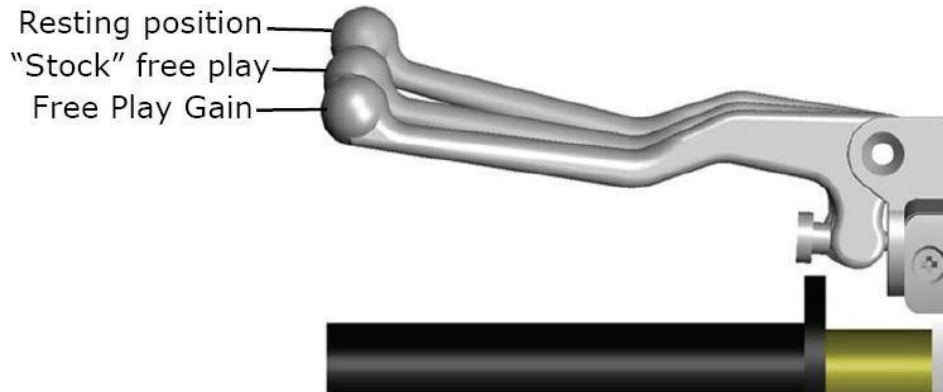

Note: *It is very important the motor returns to idle before revving the engine again or Free Play Gain will not be correct.*

- f) When the bike returns to idle, rest your hand across the clutch lever. Rev the engine again to 5,000-7,000 RPM so you can observe the movement while feeling for Free Play Gain with your hand.

The Hand Method

Use the hand method to check Free Play Gain before the start of every ride for optimum performance and longevity of your new clutch.

- a) Before you begin, place the bike in **NEUTRAL**, start the engine and let it warm up for 2-3 minutes to idle down and warm up the engine oil.

- b) With the bike at idle, apply enough pressure to the clutch lever to take up the initial free play (slack) in the clutch lever.

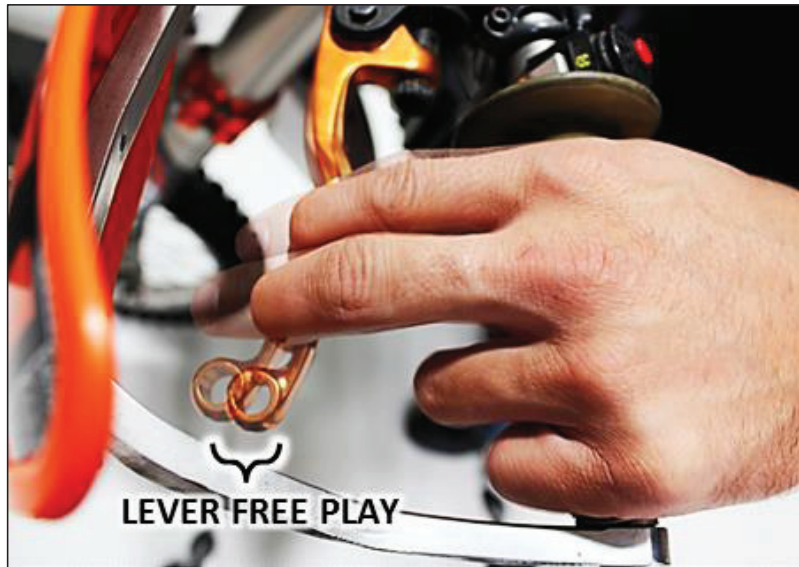

- c) While still in **NEUTRAL**, continue to apply light pressure and quickly rev the engine between 5,000-7,000 RPM (1/2 to 3/4 throttle), then let it return to idle. Notice the movement in the clutch lever when the engine is revved. This is your Free Play Gain.

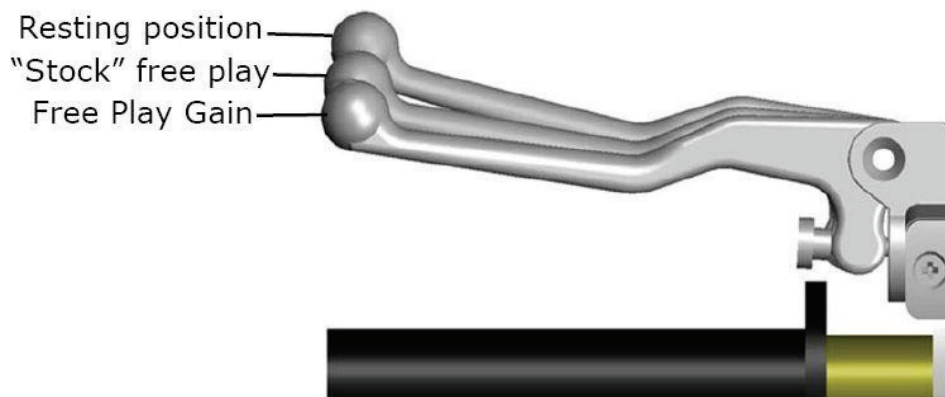

- d) When the bike returns to idle, rev the engine between 5,000-7,000 RPM a second time to feel the Free Play Gain again.
- e) Continue with Step 3 to break-in the new clutch.



Step 3: Break-in the new clutch

Once you install your new clutch, it is important to break it in. A series of roll-on starts are used to break in the clutch. Follow these procedures for breaking in your clutch and any time new friction disks, EXP bases, Teflon pads, or wedges are installed.

⚠ WARNING

Failure to follow the break-in procedure and oil screen inspection process could cause motor oil delivery failure, which can result in motor failure, serious injury, or death.

Break-in Procedure	Number of times
<p>Rev Cycles:</p> <ol style="list-style-type: none">1. Place the bike in NEUTRAL.2. With your hand off the clutch lever, rev the engine 10 times, being sure to let it return to idle between each rev cycle.	<p>① N ② ③ ④ ⑤</p> <p>10 rev cycles</p>
<ol style="list-style-type: none">3. With the engine still running, pull in the clutch lever, then click the bike into 1st gear. Slowly release the clutch lever. The bike should stay in place or have a slight amount of forward creep.4. With the bike idling in first gear, slowly apply throttle to begin moving.	<p>Continued on next page </p>

<p>5. Without using the clutch lever, accelerate moderately to approximately 5,000 RPM to fully lock up the clutch and come to a complete stop. Repeat 10 times.</p> <p>Note: <i>If the engine wants to stall or the creep is excessive, the idle may be too high or the installed gap may be too small. Make necessary adjustments before proceeding.</i></p>	 <p>10 roll-on starts</p>
<p>6. Without using the clutch lever, start in 2nd gear, then accelerate moderately to approximately 5,000 RPM and come to a complete stop. Repeat 10 times.</p>	 <p>10 roll-on starts</p>
<p>7. Place the bike in NEUTRAL and recheck Free Play Gain.</p> <p>8. Continue to step 4 to adjust the installed gap until the Free Play Gain of the clutch lever is 1/8" to 1/4" (3 mm-6 mm).</p>	 <p>Recheck Free Play Gain and adjust the installed gap</p>

Note: *Your clutch pack will expand with heat, so final adjustment to Free Play Gain should be made when the bike is warm. Remember not to ride without sufficient Free Play Gain.*

 **CAUTION**

Do not perform 3rd gear starts with this product. Starting in 3rd gear will burn up the clutch and decrease the performance of this product in a short amount of time.

Step 4: Adjust the installed gap and Recheck Free Play Gain

Once you have learned how to check Free Play Gain, you need to finish adjusting the installed gap, then recheck the Free Play Gain until the clutch lever moves only 1/8" to 1/4" (3 mm-6 mm). The gap is adjusted by turning the slave cylinder screw.

- a) With the bike running and in **NEUTRAL**, locate the adjuster screw in the center of the adjustable slave cylinder.
- b) Use a 4 mm Allen wrench to turn the adjuster screw clockwise 1 tick mark from the last setting, then recheck Free Play Gain.



Tick marks are located on the slave cylinder, and an etch mark is on the screw. If you need to re-position the Allen wrench, you can use these marks for reference.

- c) Continue to adjust the slave cylinder 1 tick mark at a time until optimal Free Play Gain is achieved.
- d) Refer to the following pictures and chart in the next section for additional adjustment information.
- e) The Free Play Gain will change as the clutch pack wears over time.
- f) Checking the Free Play Gain is easy and indicates when the install gap needs adjusting.

FREE PLAY GAIN ADJUSTMENTS

Make each adjustment in small increments - one tick mark at a time. After each adjustment, recheck Free Play Gain until you achieve the optimal 1/8" to 1/4" (3 mm-6 mm) of clutch lever movement.



Symptom	Reason	Solution
<ul style="list-style-type: none"> • Clutch lever moves in too far (too much Free Play Gain) • Clutch has excessive drag or stalls • It is difficult to fully override the clutch with the lever 	<p>Installed gap is too small</p>	<p>Turn the adjuster screw clockwise 1-2 marks to increase the installed gap and decrease Free Play Gain. Recheck Free Play Gain.</p>
<ul style="list-style-type: none"> • Clutch lever only moves slightly or does not move at all (too little Free Play Gain) • Clutch slips • Bike seems to lose power 	<p>Installed gap is too large</p>	<p>Turn the adjuster screw counterclockwise 1-2 marks to reduce the installed gap and increase Free Play Gain. Recheck Free Play Gain.</p>

LEVER SAFETY STRAPS

Your kit includes a Velcro strap to be used to secure either the clutch lever or the front brake lever when the bike is parked.

This strap is intended to reduce the risk of injury or damage that may occur from the bike rolling or launching unexpectedly with or without a rider. Use the lever safety strap every time you park or leave the bike. **Refer to the Safety Information sheet for more information.**

1. Pull the lever tight against the handlebar.
2. Wrap the Velcro safety strap around the lever and handlebar, pull it tight, then fasten it.

Clutch lever strap: Use to prevent unwanted launching.

Brake lever strap: Use as a parking brake.



MAINTENANCE

To keep your clutch performing at its best, perform regular maintenance on your bike and clutch.

- Keep up with regular oil changes as per the bike manufacturer's recommendations. Clutch performance and longevity depend on oil quality. Oil recommendations can also be viewed under Tech Tips

on our website at www.rekluse.com/support/videos/atv-mc-support-videos.

- Inspect all of your clutch parts for signs of wear or excessive heat, and replace components as necessary. Clutch wear is dependent on the riders use.

Maintenance Protocol	Maintenance Intervals
Check and verify Free Play Gain	Every ride
Inspect all clutch parts for excessive wear or heat. Replace as needed.	Refer to OE service manual
Change oil, inspect and clean oil screen	Refer to OE service manual

- Inspect the dampers, and replace them if you feel any movement between the two hubs. Refer to the section on inspecting the dampers for more information.
- Maintain adequate Free Play Gain. Check before every ride and adjust if necessary.
- Replace friction disks if the disks are glazed and/or burnt.
- Measuring the clutch pack and/or the EXP disk can help determine if the components need replacing. See **Setup Sheet** for specifications.
- Repeat the break-in procedure anytime you replace the EXP bases, Teflon pads, EXP wedges, or frictions disks. Always soak friction disks or EXP bases in oil for at least 5 minutes before installing.
- Replace the drive plates if they show signs of excessive heat.

Disk inspection examples

When inspecting the clutch pack, the following pictures can be used as a reference. **These are best viewed in color by viewing this install document on our website at www.rekluse.com/support.**

Drive Plates – If the clutch pack is getting high amounts of heat, purple, blue, or black color can be seen on the drive plate teeth. See pictures below. Not all drive plates look the same and may look different than pictured.

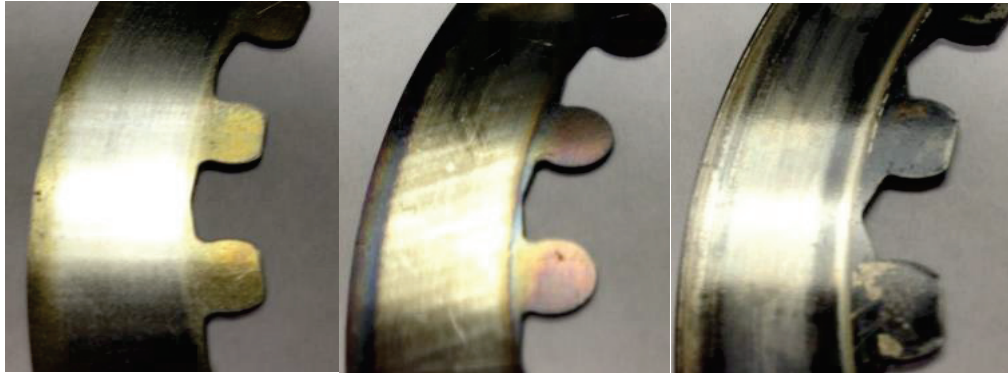

Normal Heat

High Heat
(Blue)

Excessive Heat
(Black)

Friction Disks – Due to the dark color of the friction material, the friction disks will appear almost black as soon as they are put in oil. During inspection, look for glazing of the friction material. Glazing will appear shiny and feel like glass, even after oil is cleaned from the friction disk. Not all friction disks look the same and may look different than pictured.

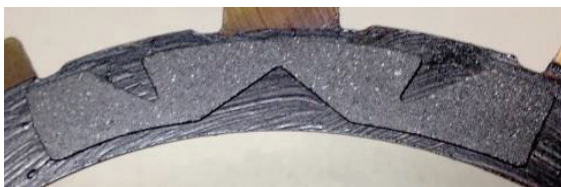

Normal Friction



Glazed Friction

TROUBLESHOOTING

Performance issues

If you find yourself adjusting the slave cylinder to fix Free Play Gain or drag, the clutch disks might be worn. Excessive heat or clutch slip can cause premature clutch failure as well. Once extreme temperatures are reached, irreversible damage will occur.

- Inspect all of your clutch parts for signs of wear or excessive heat, and replace components as necessary. Clutch wear is dependent on the riders use.
- Measuring the clutch pack and/or the EXP disk can help determine if the components need replacing.

Clutch noise

Although it is harmless, some bike models may have “squeal” or “chatter” coming from the clutch at low RPM as it engages. Clutch squeal is caused by the clutch components vibrating as the clutch engages and can become more audible as the clutch gets hot. Adjusting the installed gap will NOT affect clutch squeal or chatter.

For bike models that have clutch squeal or chatter here are some recommendations to reduce or eliminate it:

- Change the oil: For optimal clutch performance Rekluse recommends using fresh, clean oil that **meets JASO-MA** oil rating requirements. Dirty or old oil can make the clutch more likely to squeal or chatter.

EXP TUNING OPTIONS

Adjusting the engine idle speed to match your engagement setting is important and greatly affects the overall feel of how the EXP disk engages.

To prevent freewheeling and maximize engine braking, set the idle so there is a slight amount of drag while the bike is idling in gear and warmed up. The idle should not be so high as to move the bike forward in gear with the throttle closed. However, with a small opening of the throttle the bike should move forward.

You can tune the engagement RPM of the EXP disk by changing the spring configuration. The EXP disk comes set with the recommended “**Medium**” setting from Rekluse. Use the following steps to change the springs. It is **NOT necessary** to disassemble the EXP halves to change springs!

EXP tuning options are bike specific. See the **Setup Sheet** for EXP tuning options.

Changing the springs

1. Using a flat-blade screwdriver, push the ¼ turn pin in far enough to clear the opposite side of the EXP to unlock the pin.
2. With the pin still pushed past the base, turn 90° to remove the pin and spring.

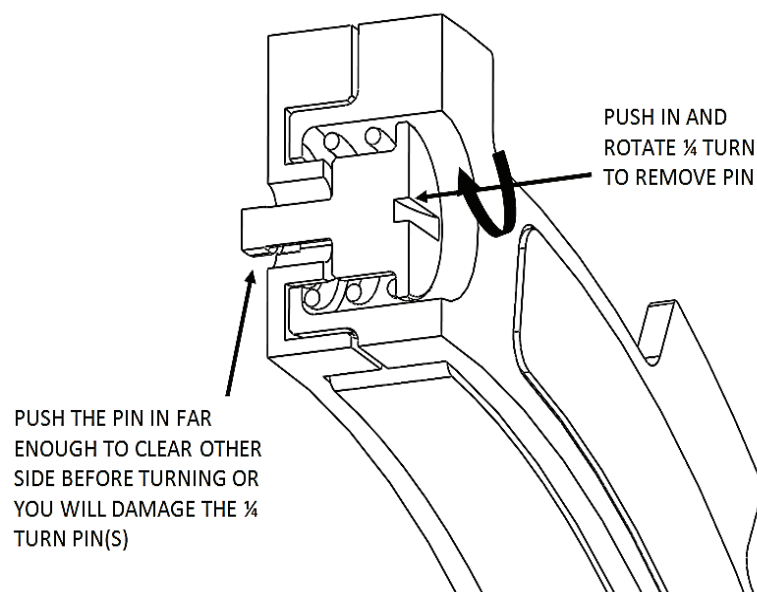

3. Remove the remaining 2 pins and springs from the same side of the EXP base.
4. Drop a new spring into the spring slot on the base, then add the $\frac{1}{4}$ turn pin.

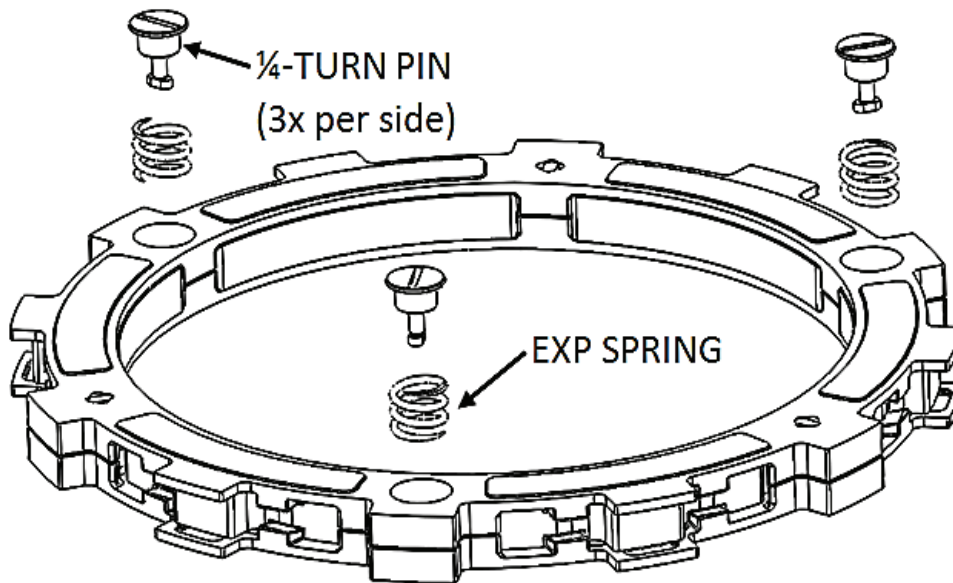

5. Push the turn pin in far enough to clear the base, then turn 90° and release the pin. The pin should sit almost flush with the EXP base.
6. Flip the EXP friction disk over, and repeat on the other side depending on engagement preference.
7. If you need to disassemble the EXP disk, you can watch the video on our website under Tech Tips at www.rekluse.com/support/videos/atv-mc-support-videos.

Note: To maintain even pressure, when using two different color spring sets, install one set of 3 on one side of the EXP and the remaining set of 3 on the other side.

⚠ CAUTION

If you disassemble the EXP, the Teflon pads may fall out or be stuck to the ramp surfaces of the EXP bases. Take care to ensure all pads are correctly placed into wedge

pockets using gentle pressure to avoid damage to the pad surfaces before reassembling the EXP. Properly seated pads will be secured in place once the EXP is reassembled. Operating the clutch without the pads in place will cause part damage or failure.

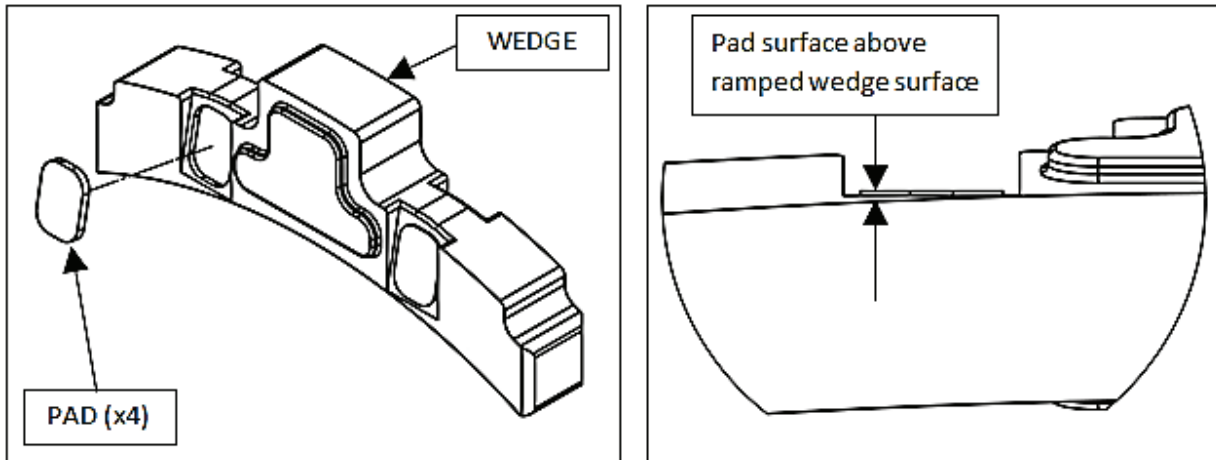

BUMP-STARTING

If your bike needs to be bump-started due to a dead battery or any other reason, follow the steps below to quickly bump-start your bike.

1. Turn the adjustable slave cylinder counterclockwise to collapse the gap until no resistance is felt.
2. Bump start the bike. The clutch will function like a manual clutch at this point, but the clutch will not be fully over-ridable at high RPM.
3. Once the bike is started, readjust the installed gap.

NEED ADDITIONAL HELP?

Website

www.rekluse.com/support

Frequently Asked Questions

www.rekluse.com/faq

Support Videos

www.rekluse.com/support/videos

Phone

(208) 426-0659

Technical Support

Contact Technical Support for questions related to product installation, tuning, and performance.

Technical Support hours:

Monday thru Friday: 8:00 a.m. - 5:00 p.m.

Mountain Time zone

Email: tech@rekluse.com

Customer Service

Contact Customer Service for additional product information, orders, and returns.

Customer Service hours:

Monday thru Friday: 8:00 a.m. - 5:00 p.m.

Mountain Time zone

Email: customerservice@rekluse.com



SETUP SHEET 198-7917001

DOC REVISION: 112017

CLUTCH PACK CONFIGURATION

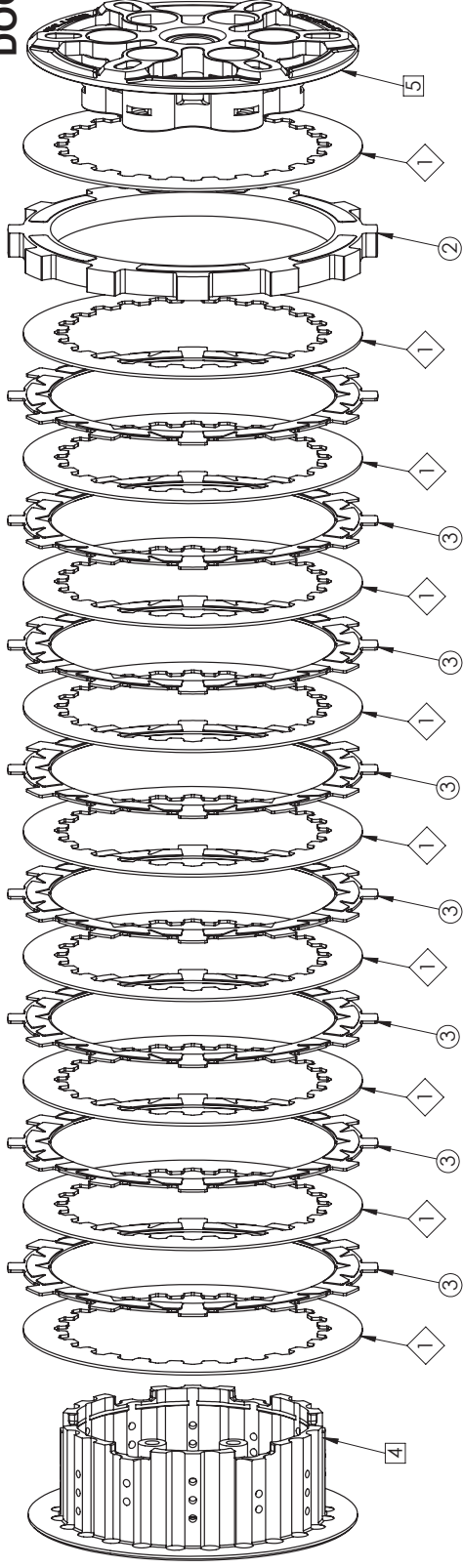

ITEM NO.	DESCRIPTION	QTY.
1	DRIVE PLATE	10
2	EXP DISK	1
3	FRICION DISK	8
4	CENTER CLUTCH HUB	1
5	PRESSURE PLATE	1

CLUTCH PACK SPECS & SERVICE LIMITS

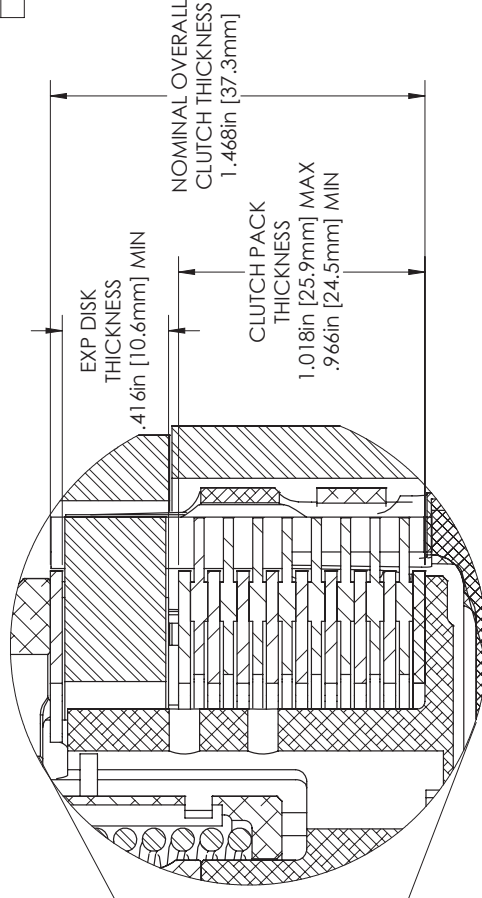

EXP TUNING OPTIONS

ENGAGEMENT RPM SETTING	SPRING CONFIGURATION
LOW	3 SILVER & 3 RED
MEDIUM *	6 RED
HIGH	3 RED & 3 BLUE

* MEDIUM SETTING IS PREINSTALLED IN THE EXP DISK

