



INSTALLATION & USER'S GUIDE

RadiusCX Clutch
For KTM/Husqvarna DDS clutches

Doc ID: 191-7905A
Revision: 061621

TABLE OF CONTENTS

OVERVIEW	3
INSTALLATION TIPS	3
Tuning Note	4
TOOLS NEEDED	5
INCLUDED PARTS	6
DISASSEMBLE THE CLUTCH	7
INSPECT THE DAMPERS	9
INSTALL HUBS	10
CLUTCH PACK INSTALLATION	12
PRESSURE PLATE INSTALLATION	17
SLAVE CYLINDER INSTALLATION	22
Step 1: Bleed the new slave cylinder	22
Step 2: Replace OE slave cylinder	25
SET THE INSTALLED GAP AND VERIFY BY CHECKING FREE PLAY GAIN	32
Step 1: Find the starting point	33
Step 2: Learn how to check Free Play Gain	34
Two Ways to Check for Free Play Gain	36
The Rubber Band Method	36
The Hand Method	38
Step 3: Break-in the new clutch	39
Step 4: Adjust the installed gap and Recheck Free Play Gain ...	42
FREE PLAY GAIN ADJUSTMENTS	43
MAINTENANCE	44
Disk inspection examples	46
TROUBLESHOOTING	47
Performance issues	47
Clutch noise	47
EXP TUNING OPTIONS	48
Configuration chart	48
Changing the springs	49
BUMP-STARTING	50
NEED ADDITIONAL HELP?	51

OVERVIEW

This kit replaces many of the OE (Original Equipment) clutch parts while reusing some of the OE clutch parts. The following is a summary of what is replaced and what is reused:

- The OE center clutch hub and OE pressure plate. The OE clutch is replaced with high-quality billet components. These parts are designed specifically for your motorcycle to ensure optimal performance.
- All OE steel drive plates will be replaced with Rekluse TEC drive plates
- All OE friction disks will be replaced with Rekluse TorqDrive® disks
- All 6 of the OE drive pins will be reinstalled
- The OE clutch cover O-ring will be reused

INSTALLATION TIPS

- Read the safety information sheet included with your kit.
- If you install this product for a customer or another person, instruct them to read the Safety Information document and the Installation and User Guide before operating the bike with the product.
- Watch the “RadiusCX Auto Clutch Installation Video” by visiting www.rekluse.com/support/videos.
- Protect eyes and skin – wear safety glasses and thin disposable work gloves.
- Read this entire document before performing any steps.
- Lay the motorcycle on its left side when replacing the clutch. This makes the clutch work easier and eliminates the need to drain the oil.

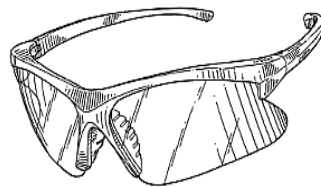







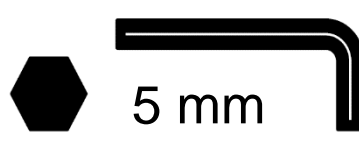

- Use an air or electric impact wrench to remove the center clutch nut. If one is not available, you can place the bike in top gear and hold the rear brake while loosening the center clutch nut with a socket and breaker bar.
- Channel-lock pliers work best to bend the tabs of the washer up over the center clutch nut.
- For optimal clutch performance Rekluse recommends using fresh, clean oil that **meets JASO-MA** oil rating requirements. Rekluse offers Factory Formulated Oil™ developed specifically for Rekluse products. Rekluse Factory Formulated Oil is a perfect complement to any OEM or aftermarket wet clutch. Visit www.rekluse.com to learn more.
- Motorcycles with taller gearing or modified engines with increased horsepower may require heavier wedges. These can be purchased separately from Rekluse.

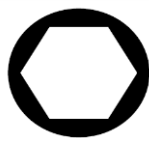
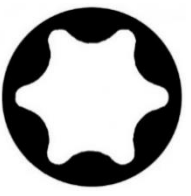
Tuning Note: (especially for 2-stroke owners):

- Once installed, if you desire your clutch to engage more aggressively, one option is to purchase the heavier Belleville spring from KTM (KTM calls it the “280” spring).
- Replacing this spring makes the clutch engagement more aggressive. However, this will increase the pull on the clutch lever. The spring comes stock on 2013 and newer Factory Edition 450SX-F bikes, 2014 and newer 450SX-F/XC-F bikes, 2017 and newer 450/500 EXC-F bikes.
- The part number is KTM Part #: 78932005000

TOOLS NEEDED

 4 mm	 5 mm	 8 mm	 27 mm
4 mm Allen Wrench	5 mm Allen Wrench	8 mm Socket	27 mm Socket
			
T-25 Torx Bit	Torque Wrench	Fluid Catch Container	Channel-lock Pliers
			
Oil	Recommended Clutch Fluid		

INCLUDED PARTS

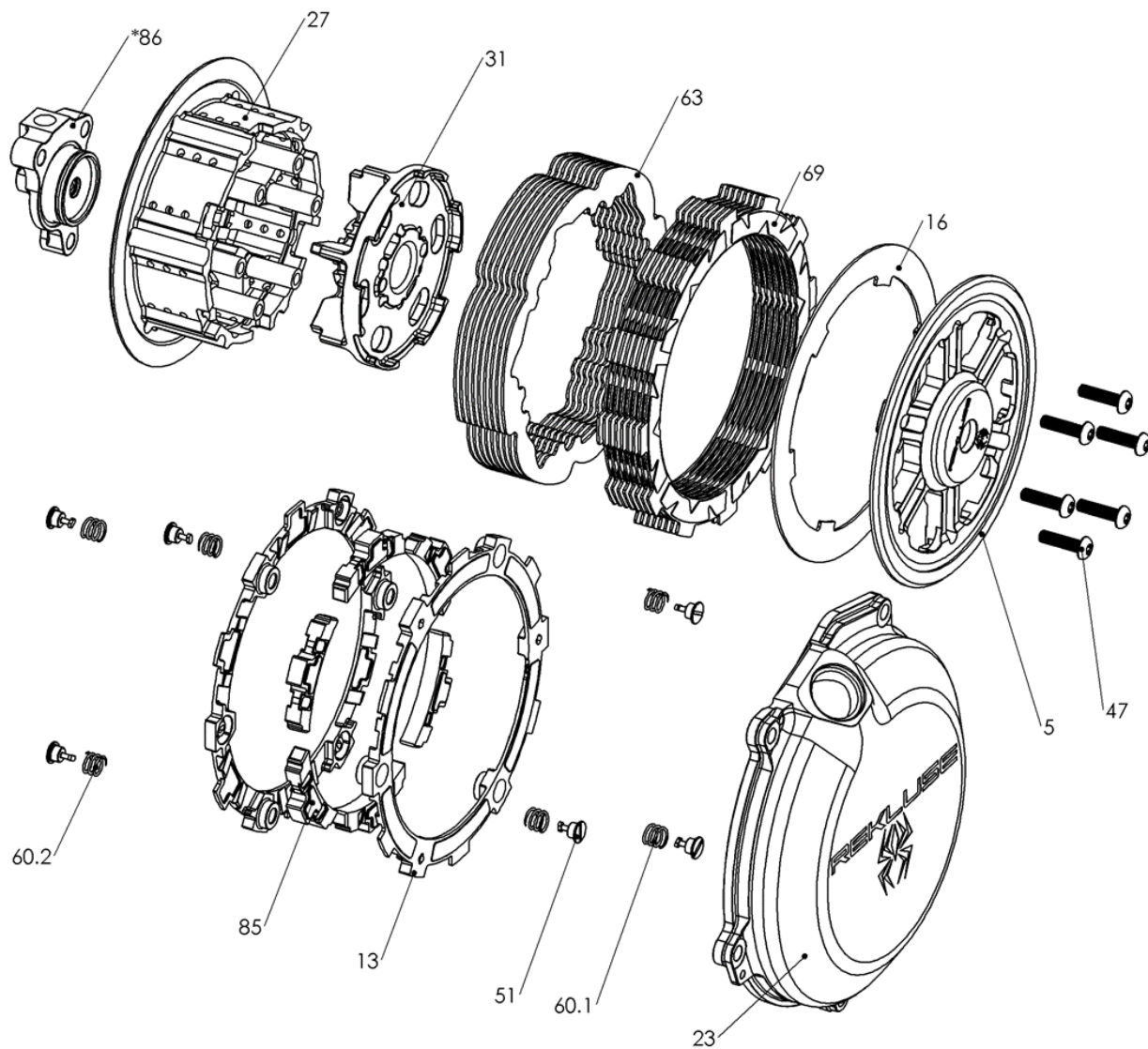

Item	Description	Qty.
5	Pressure Plate	1
13	EXP Bases	2
16	Steel Lining Plate	1
23	Clutch Cover	1
27	Outer Hub	1
31	Inner Hub (Included for 450SX-F and 450XC-F model clutches)	1
47	Fastener - M5 x 20 T-25 Torx Screw (T-25 Torx bit included)	6
51	Fastener - 1/4-Turn Pin	6
60.X	EXP Adjustment Spring (Extra adjustment springs are included. See EXP tuning options section for more information.)	6
63	TEC Steel Drive Plate	9
69	TorqDrive® Friction	8
85	Wedge Assembly	6
86	Adjustable Slave Cylinder Assembly (bleed syringe included)	1

Visit www.rekluse.com/support for a full parts fiche illustration and part numbers.

DISASSEMBLE THE CLUTCH

1. Turn the fuel petcock to “OFF” if applicable.

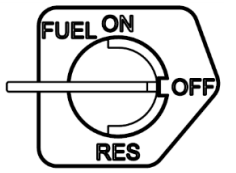

2. Lay the bike on its left side. Catch any fuel that might drain in a suitable container.



3. Use an 8 mm socket to remove the clutch cover. If your bike has an oil plug, loosen the plug before removing the cover.



4. Use an 8 mm socket to remove the following OE parts. When removing the Belleville spring, make sure to note the orientation of the spring. See following picture for reference.

- 6 pressure plate screws
- Pressure ring
- Belleville spring
- Slider ring
- Pressure plate
- Throw-out bearing and washer
- Clutch pack
- 6 drive pins
- Center clutch nut and washer
(Removed in step 5)

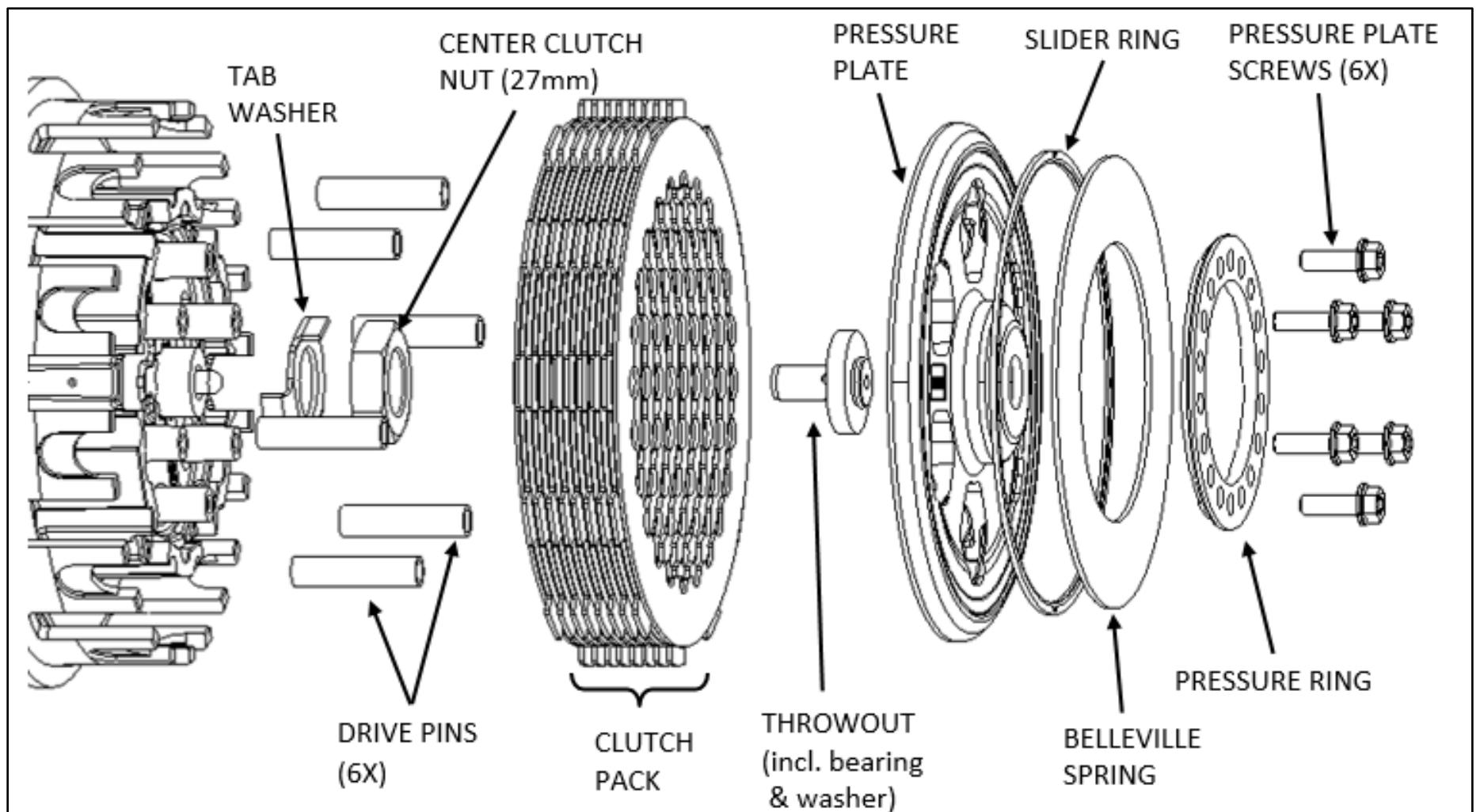

⚠ CAUTION

Be careful that the drive pins do not fall into the engine while disassembling.

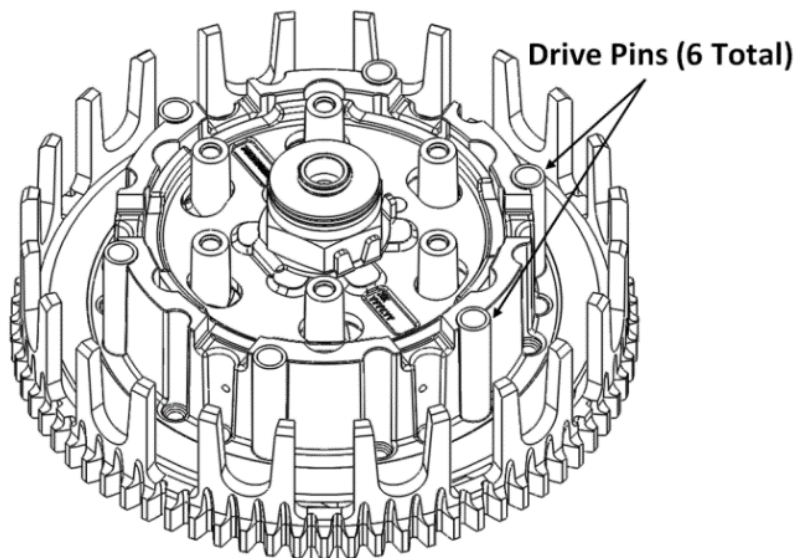

5. Use a hammer and large screwdriver to bend down the tabs of the washer tab, then remove the center clutch nut with an impact wrench or breaker bar, and a 27 mm socket.

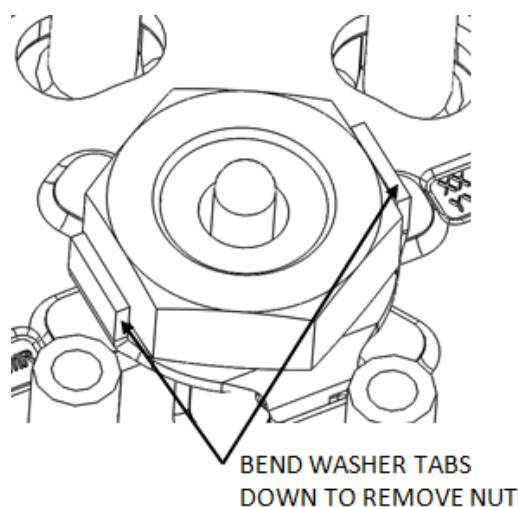

6. Remove the tab washer.

7. Remove the center hub assembly from the steel basket while leaving the thrust washer on the main shaft.

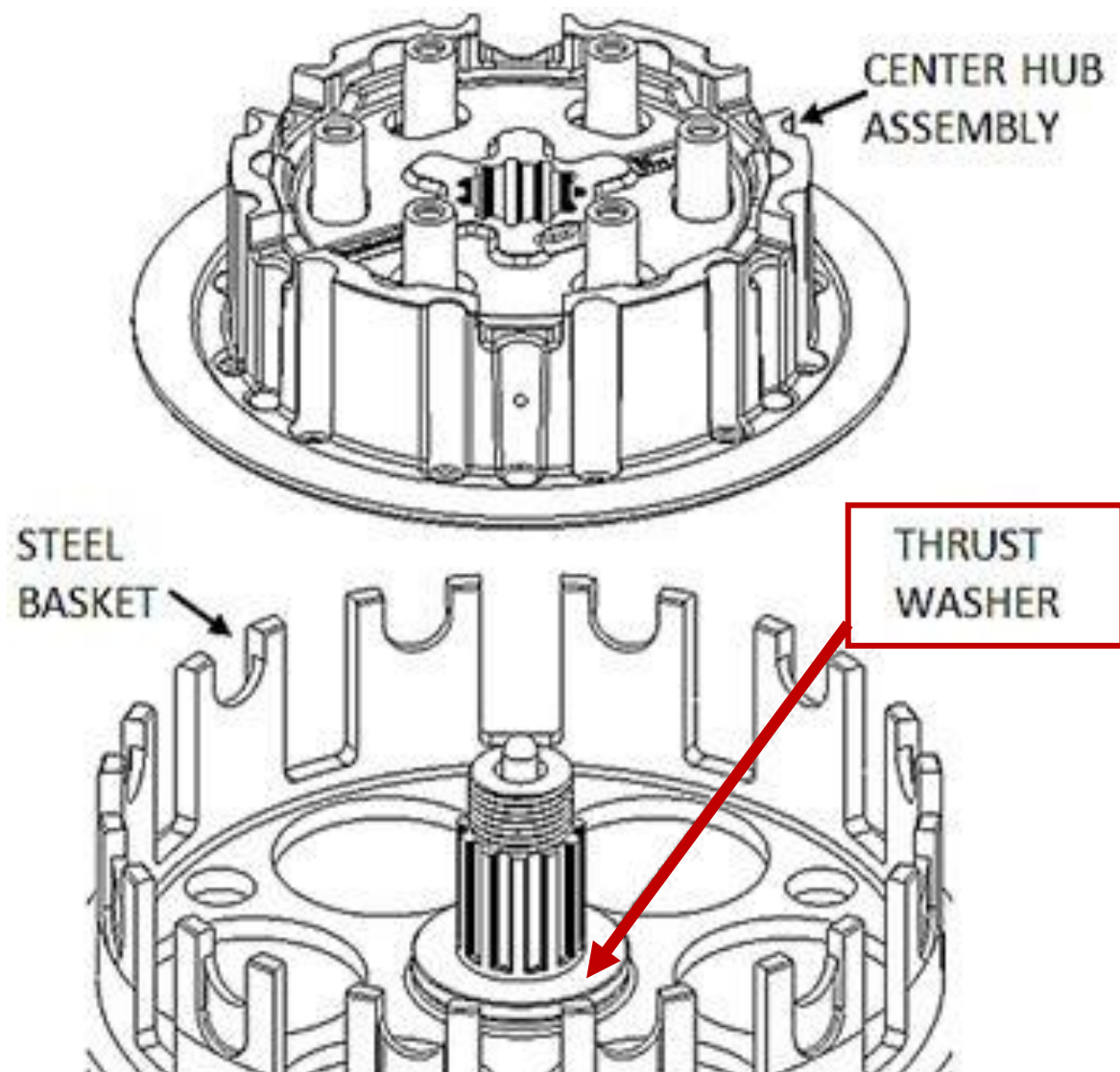

NOTICE

Check that the thrust washer is still on the main shaft and not stuck to the bottom of the center hub assembly. Missing the thrust washer will cause clutch performance issues.

INSPECT THE DAMPERS

The OE dampers inside the center hub assembly shrink due to heat and use. Any movement between the dampers will shorten the life of your clutch. Inspect the dampers before proceeding and replace if necessary. Use the following instructions to inspect the dampers.

1. Hold the center hub assembly in your hands, then place your thumbs on the inner hub by the embossed part numbers.

2. Rotate the inner hub back and forth inside the outer hub.



NOTICE

Rekluse recommends replacing the dampers if you feel any play between the two hubs - **Rekluse Damper Kit Part #: RMS-0213080**

INSTALL HUBS

1. Remove the 6 rubber dampers from the OE center hub assembly.

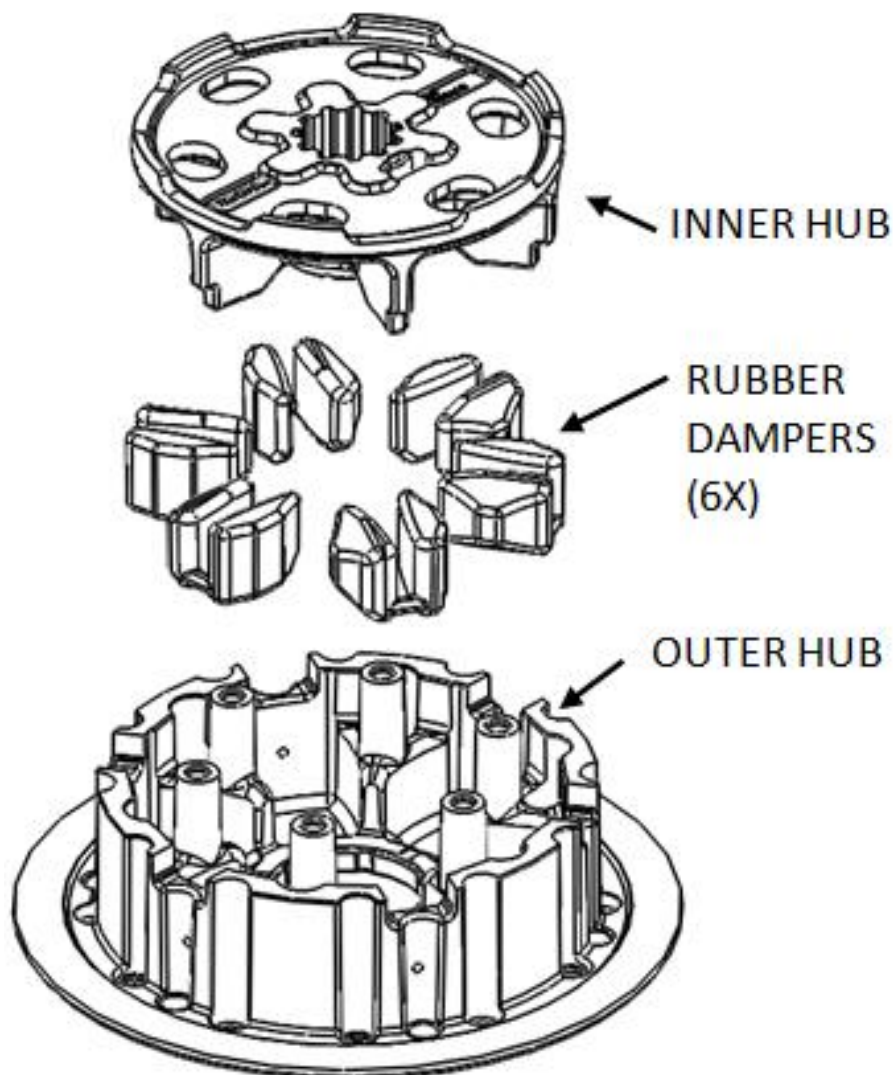

NOTICE

For 450SX-F/XC-F models, replace the OE inner hub with the supplied inner hub.

2. Install the 6 OE rubber dampers and inner hub onto the Rekluse outer hub.

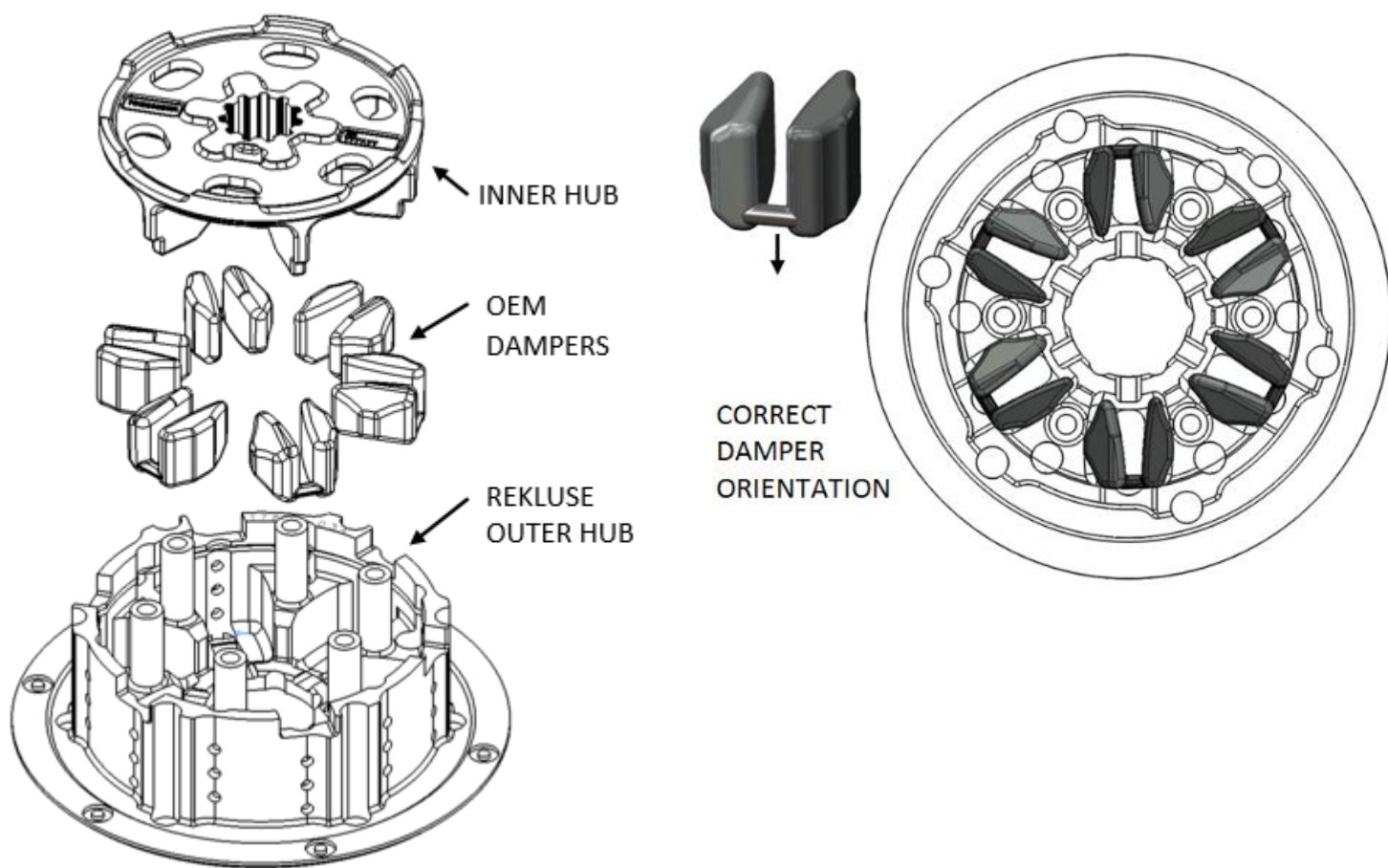

3. Install the new center hub assembly into the motorcycle.

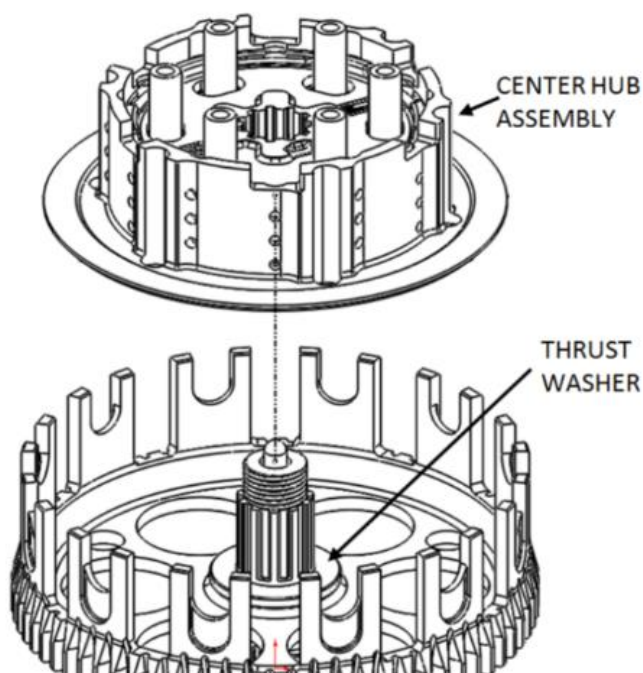

4. Reinstall the OE tab washer and center clutch nut.

NOTICE

For 450SX-F/XC-F models, use the supplied lock tab washer in place of OE lock tab washer.

5. Using the 27 mm socket and torque wrench, torque the center clutch nut to **50 ft-lb (68 N-m)**.

6. Using the channel-lock pliers, bend up **both** tabs of the tab washer around the nut.

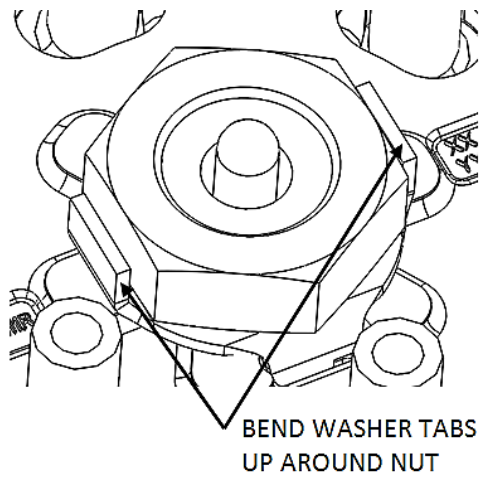

7. Seat the 6 OE drive pins into the Rekluse outer hub.

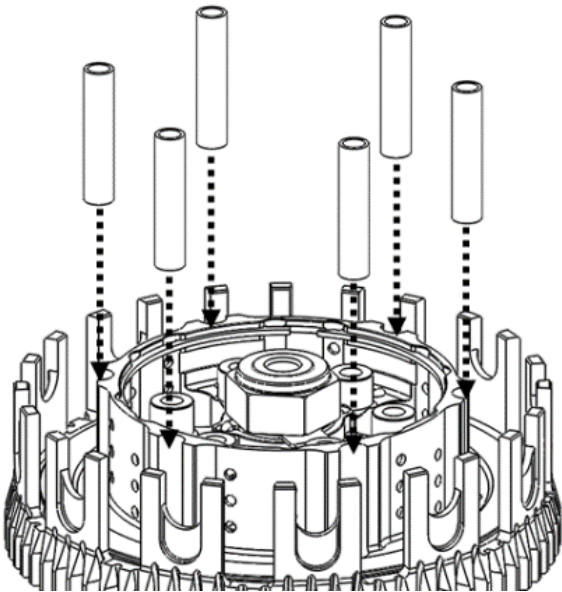

CLUTCH PACK INSTALLATION

Each clutch pack comes with a set of steel plates, a set of friction disks, and an EXP disk.

The clutch pull effort has different settings and depends on the thickness of the clutch pack. You will need to measure the clutch pack before you begin if you wish to optimize the clutch pull effort vs. clutch performance. **Please refer to the Setup Sheet for clutch pack specifications and information.** Otherwise, continue with following instructions.

1. Soak the friction disks and EXP disk in new oil for at least 5 minutes. Make sure the EXP and friction disks are coated on both sides.

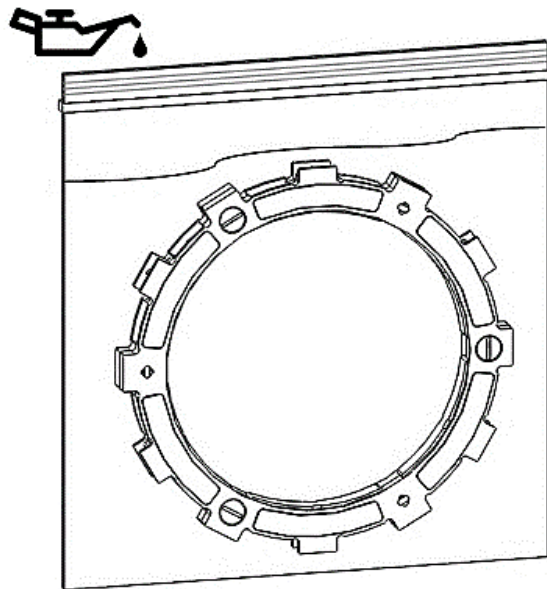

2. Install a steel TEC drive plate by first aligning the drive pin notches in the plate with the drive pins on the hub.

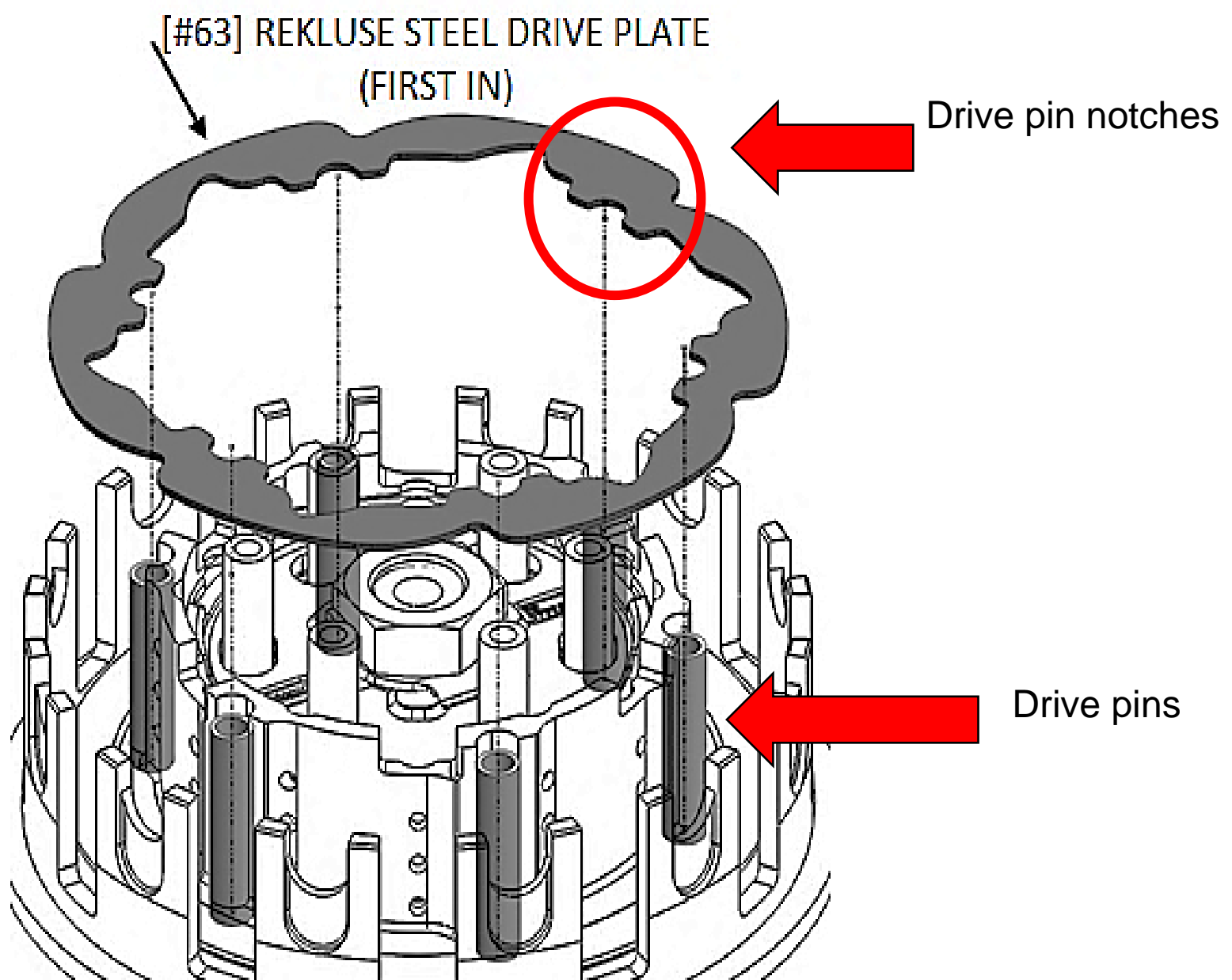

- Place the steel plates in the orientation shown with the shark fin notches facing to the right. All drive plates will follow this orientation.

NOTICE

- Proper orientation of the drive plates is critical for optimal clutch performance. If you install them backwards, the clutch will still function but will lack proper modulation performance.*

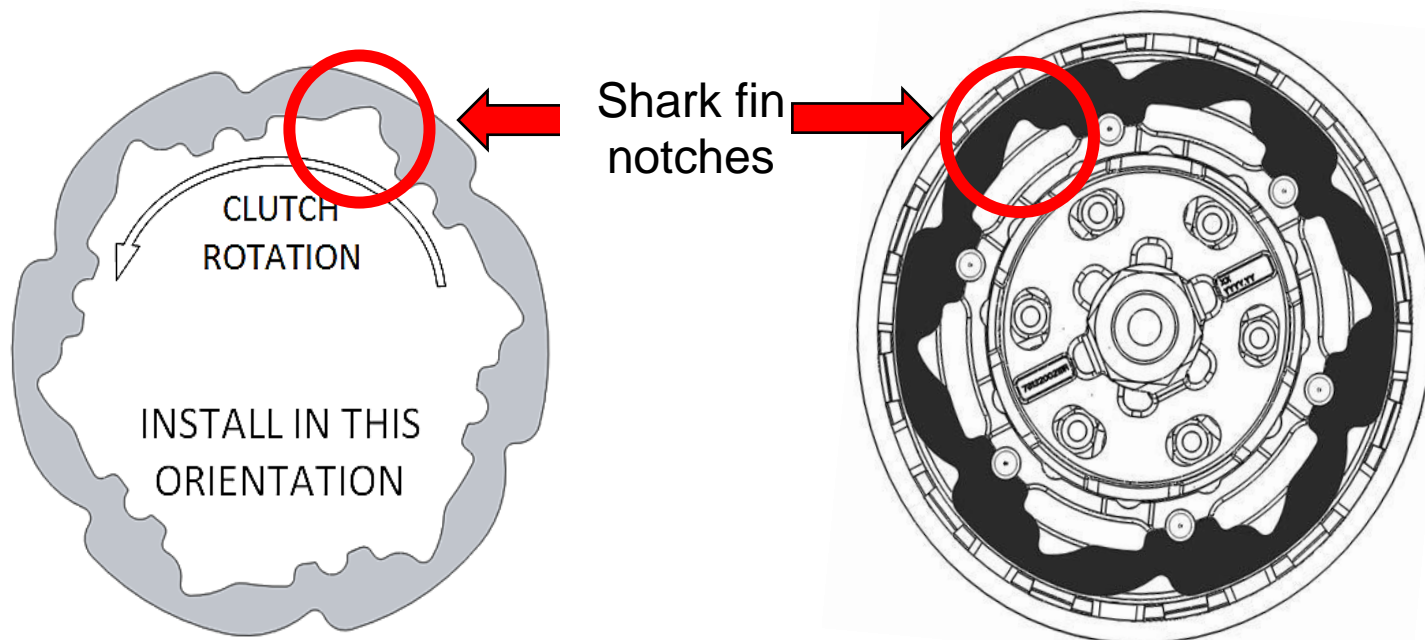

- Be sure that the drive pins are seated in the notches and not in the bigger sections. ALL the TEC plates must be aligned in the drive pins notches or damage may occur. The plates will not move when installed correctly.*

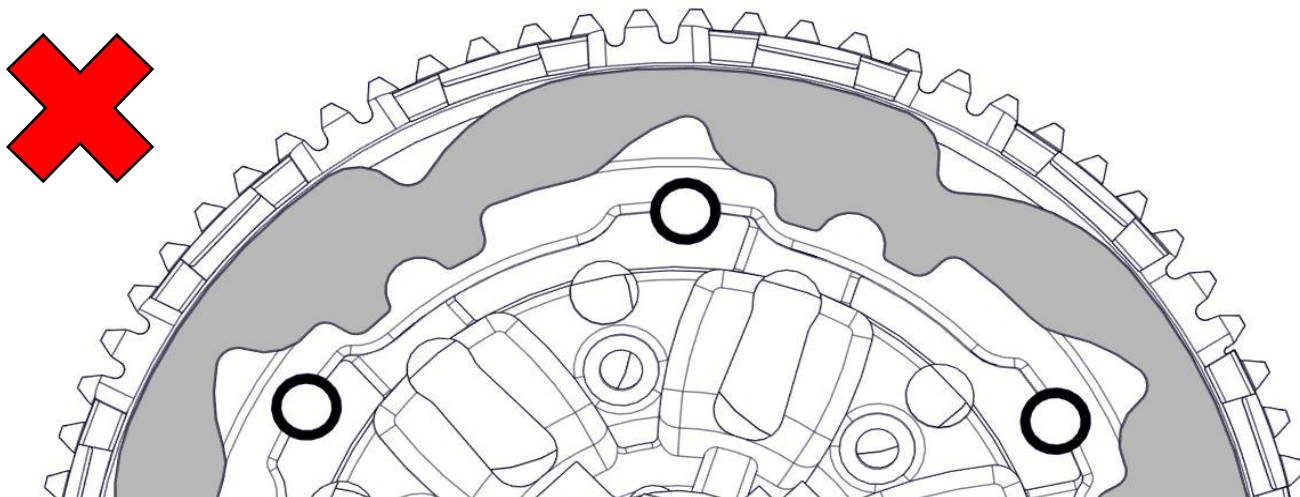
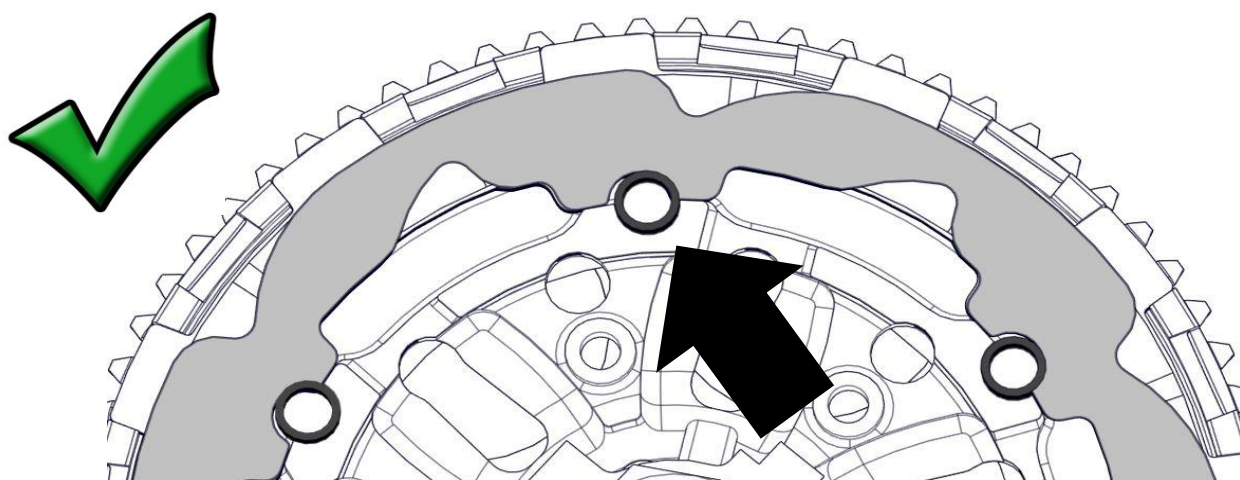

4. Add a friction disk on top of the steel drive plate. Some friction disks are marked with a small colored dot. This mark is used for processing and can be ignored.
5. Continue alternating the steel drive plates with the friction disks for the entire Rekluse clutch pack. See the following picture for reference.

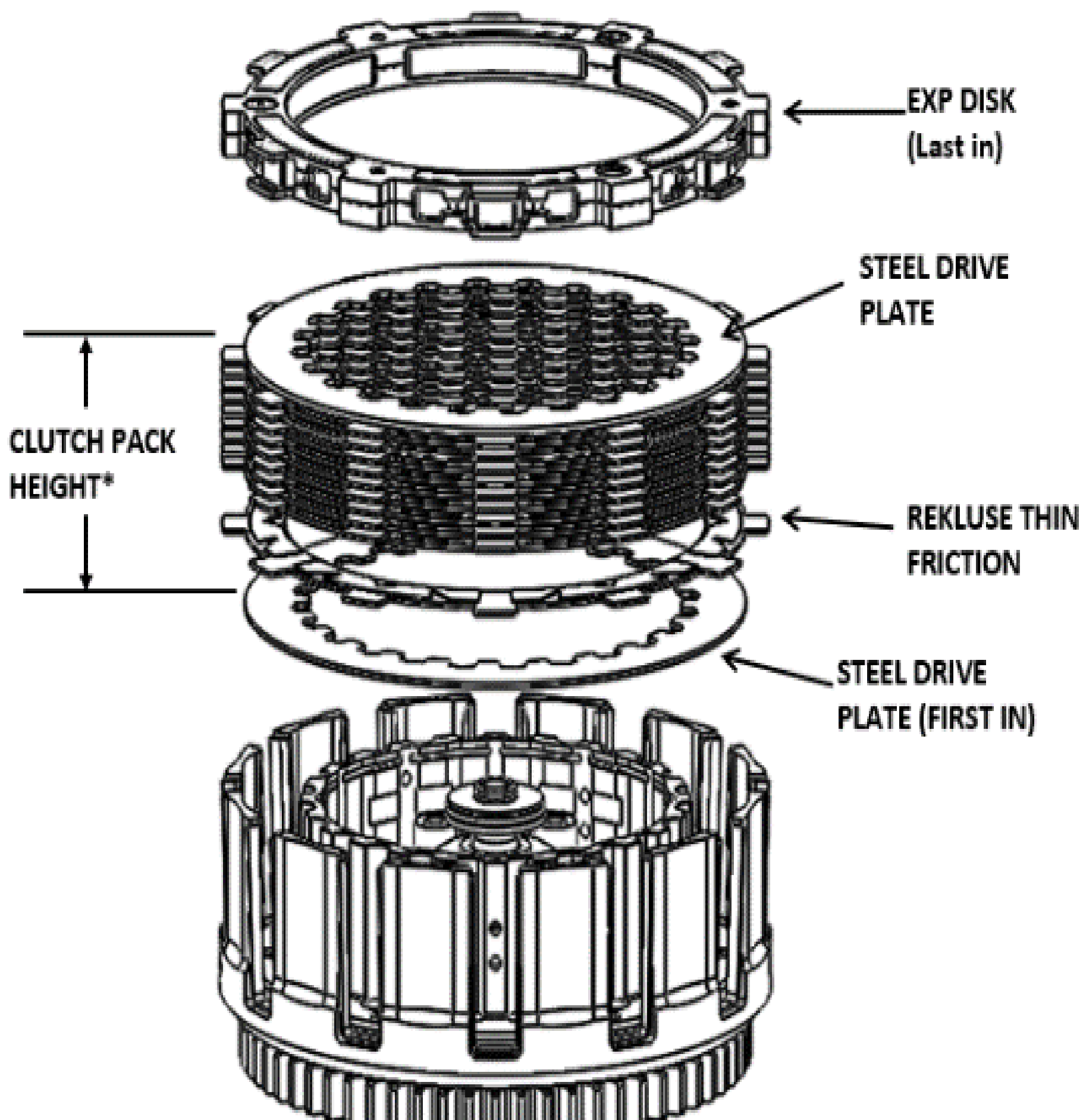

*Refer to the Setup Sheet included with the clutch kit for the "Clutch Pack Height" specifications.

6. Install the EXP disk on top of the last steel plate. Make sure that the EXP disk is seated in the same slots as the clutch pack.

NOTICE

Some OE basket have “half slots” at the top of the basket tangs. Rekluse products require the entire clutch pack, including the EXP disk, be installed into the MAIN (deeper) basket slots.

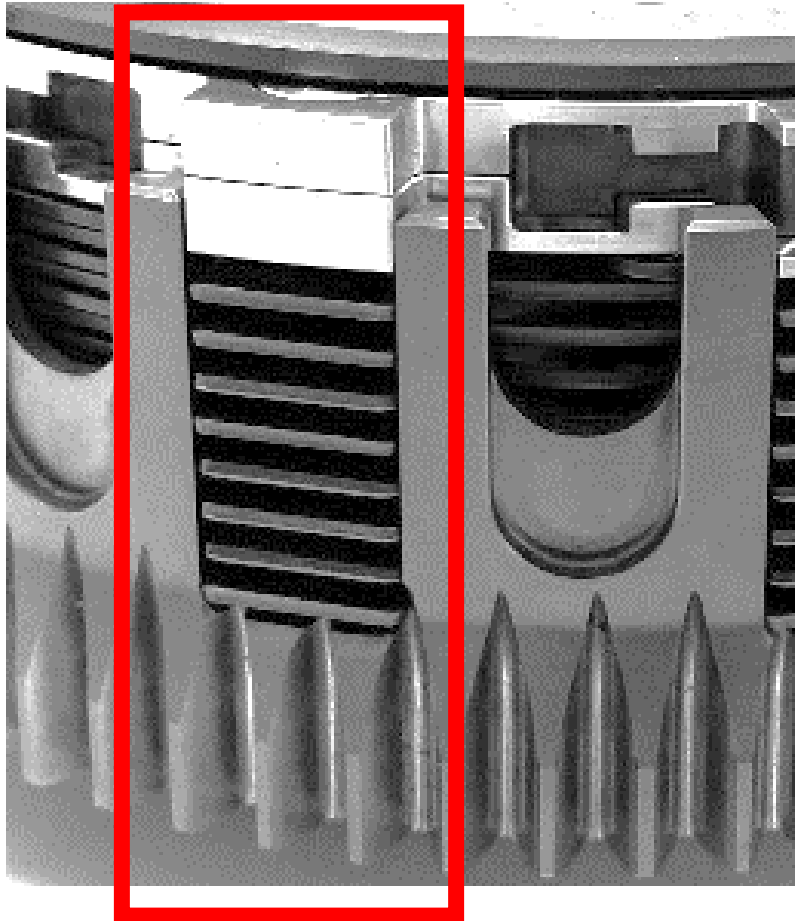

7. Reinstall the OE throw-out.

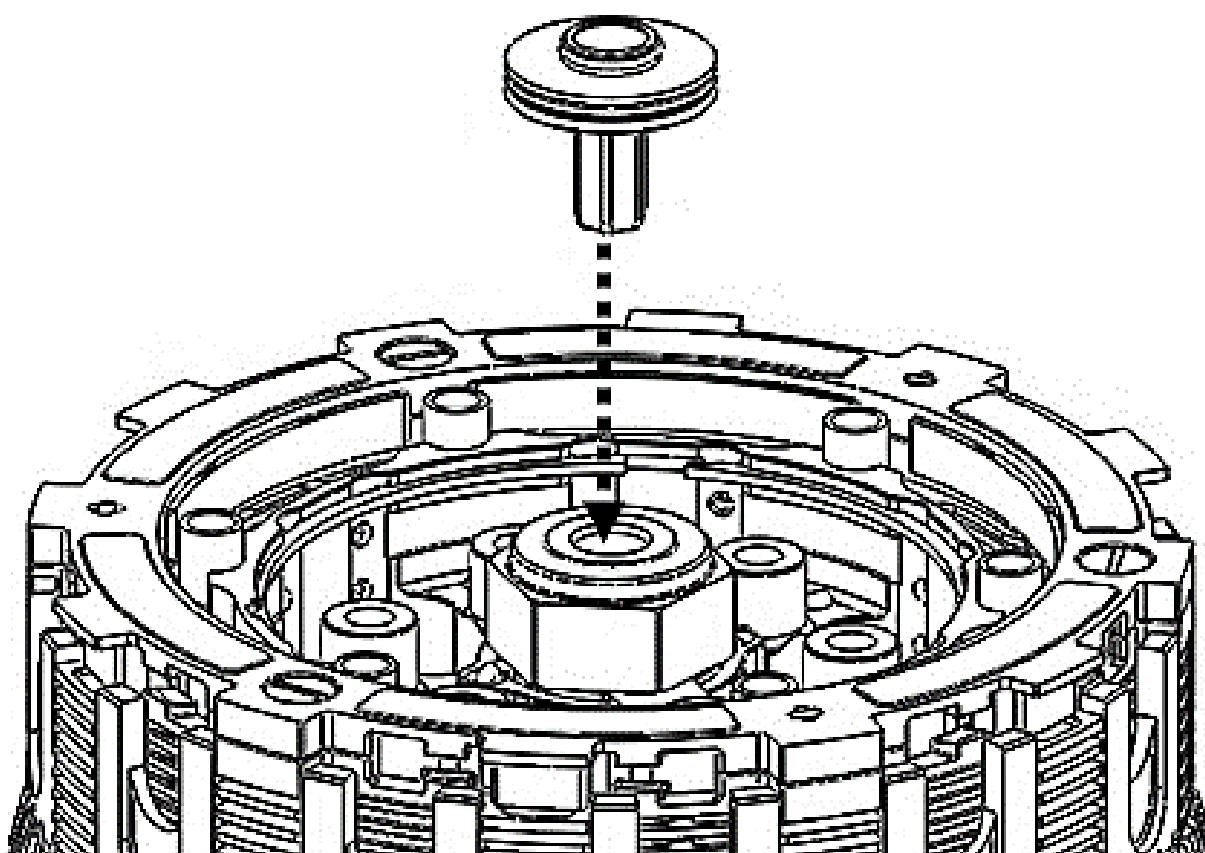

PRESSURE PLATE INSTALLATION

1. Add a light film of oil between the lining plate and pressure plate. This will help the plates stick together for ease of installation.
2. Install the supplied lining plate onto the pressure plate by lining up the index tabs into the slots.

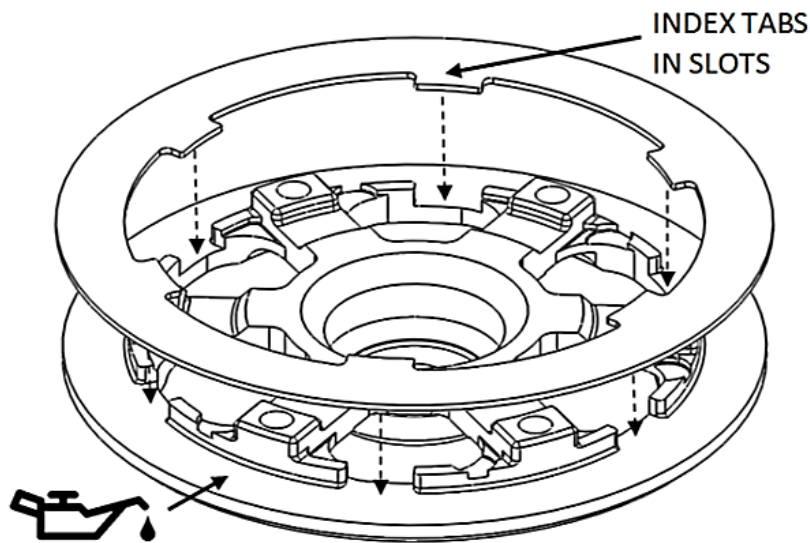

3. Install the pressure plate subassembly by lining up the index tabs on the pressure plate with the slots in the hub.

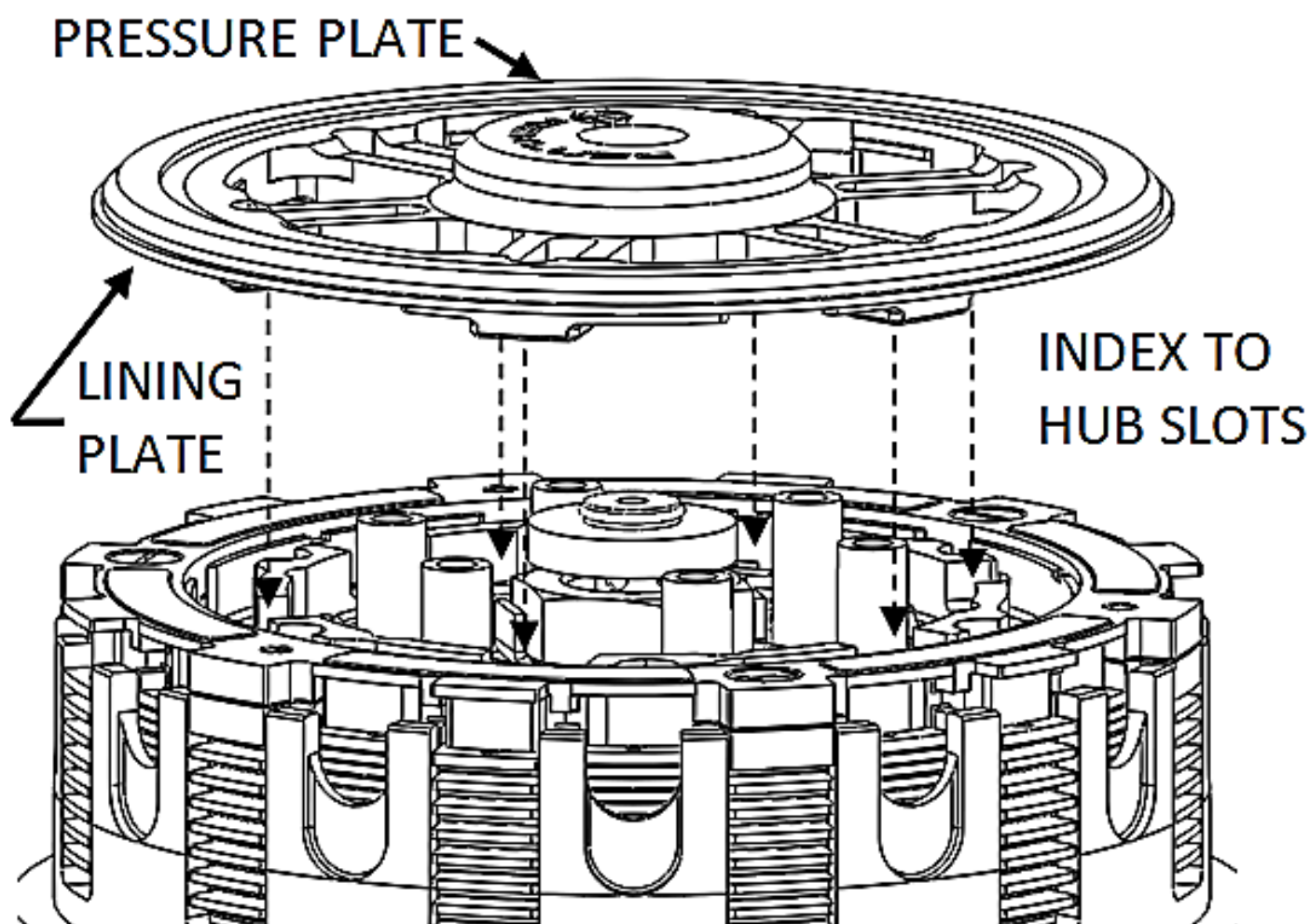

NOTICE

When the pressure plate is seated correctly, the threaded standoffs will come through the openings of the pressure plate.

4. Place the OE slider ring on the pressure plate with the “top” marking facing up. (The top side is rounded and the bottom edge is sharp.)

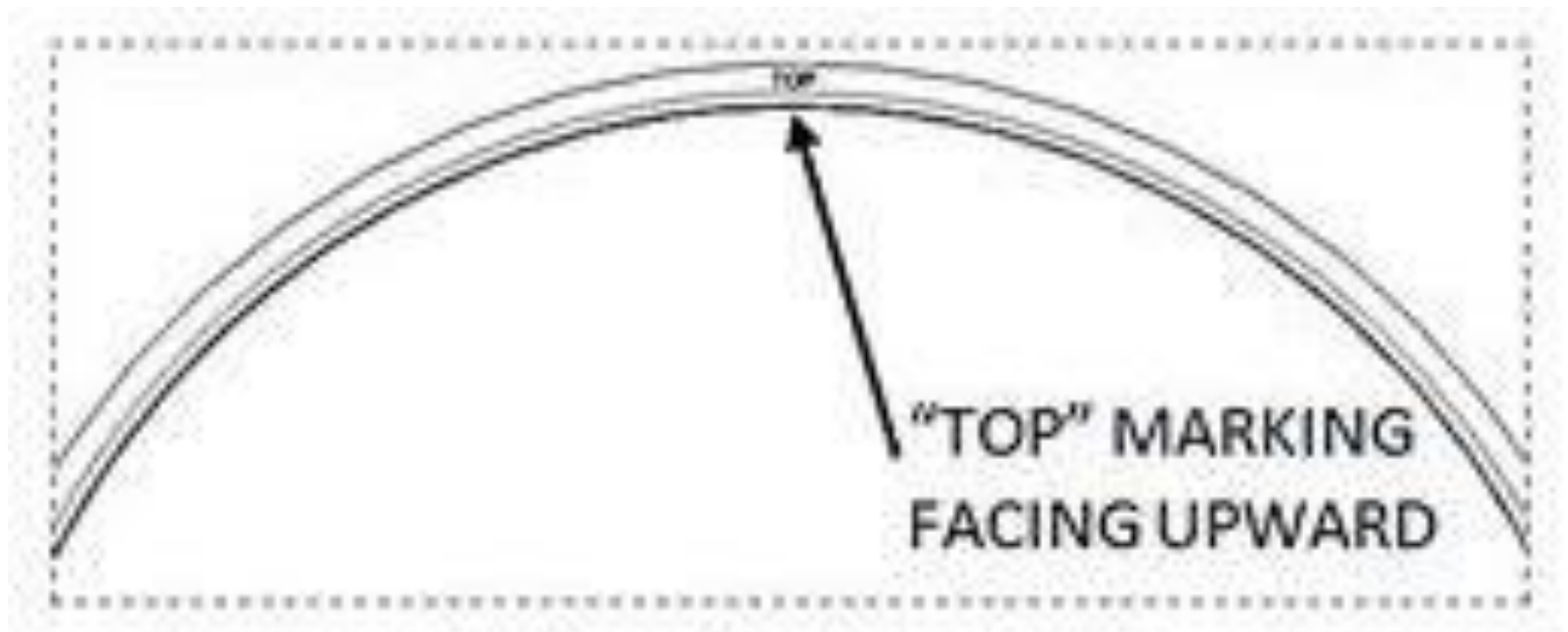

5. Place the OE Belleville spring onto the slider ring, with the rounded dome side facing up.

NOTICE

The outer edge of the Belleville spring will make contact with the slider ring. If it does not, the Belleville spring is upside down.

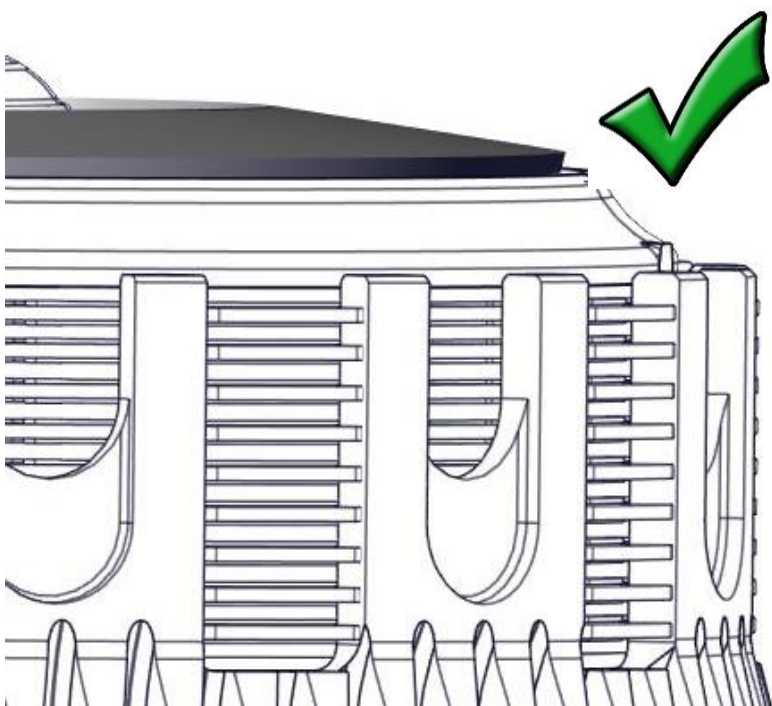

Correct – The Belleville spring sits flat against the slider ring.

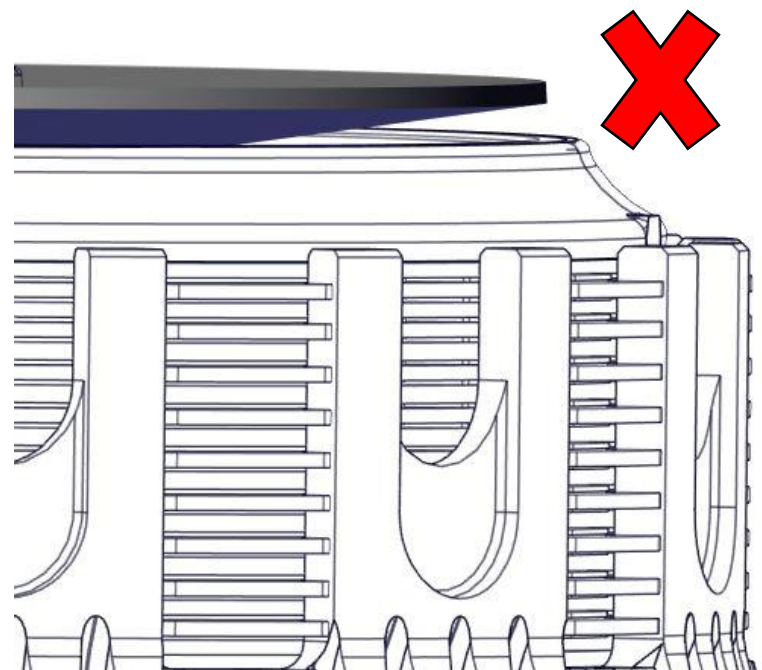

Incorrect – The Belleville spring is upside down.

6. Install the OE pressure ring, flat side up.

NOTICE

There are 3 possible settings on the OE pressure ring that will be reused with the Rekluse Clutch system. These settings will be listed as I, II, III or X, Y, Z depending on model. To select the correct setting, you must refer to the set-up sheet for optimized performance. The thickness measurement of the Rekluse clutch pack will determine the setting to be used on the OE pressure ring.

Clutch damage can occur if you do not use the correct OE pressure ring setting as stated in the Rekluse set-up sheet.

7. Install the Rekluse pressure plate screws.

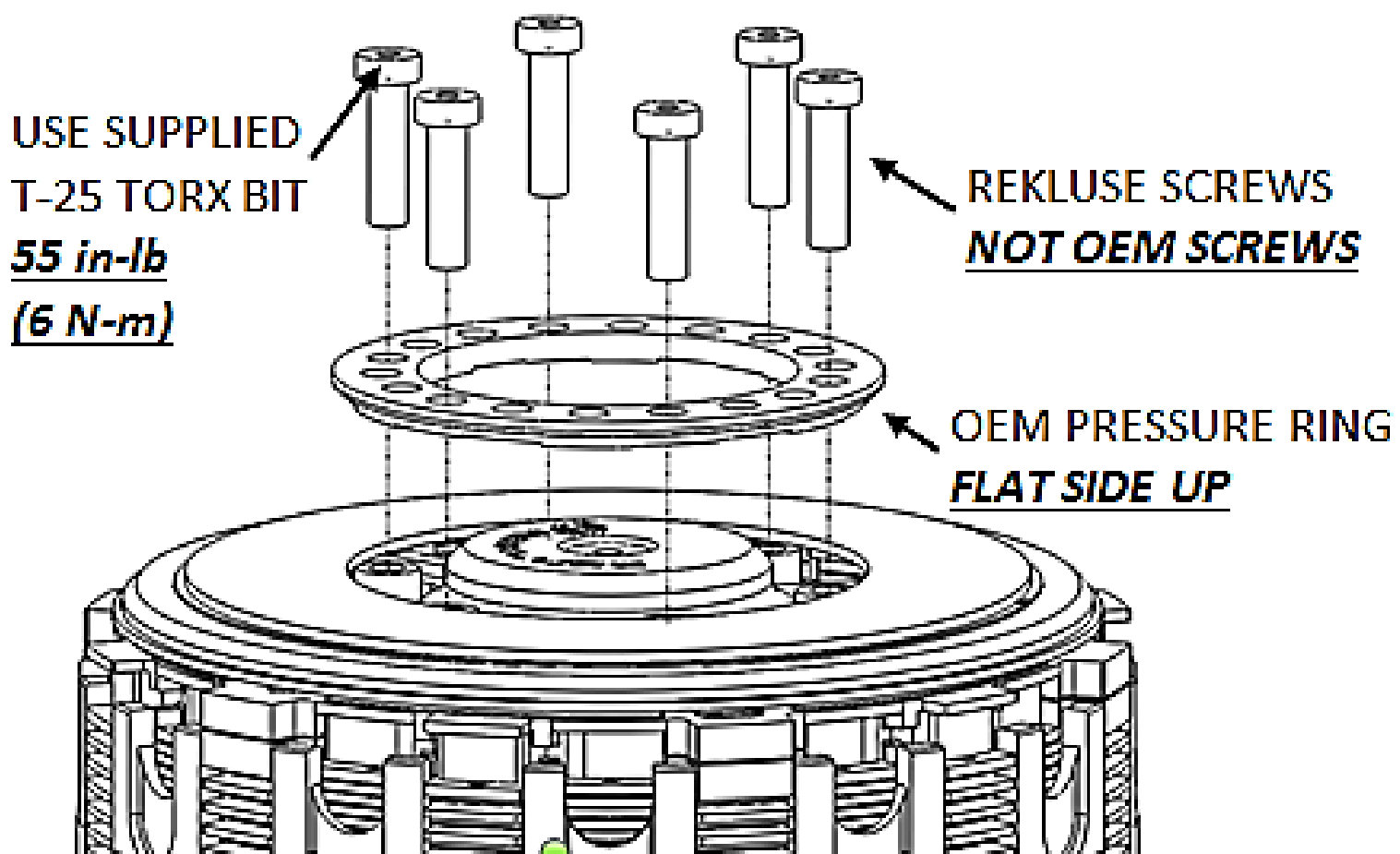

CAUTION

Do not reuse the OE screws, or clutch cover interference will occur!

8. Loosely tighten the screws, then use the T-25 Torx bit and torque wrench to tighten to 55 in-lb (6 N-m).

9. Remove the OE cover gasket from the OE clutch cover and install it onto the new Rekluse clutch cover.

250/300 2 stroke 2017+ models:

- **Use 6 OEM bolts and 1 Rekluse bolt.** Your Rekluse clutch cover kit comes with 1 longer bolt to replace a shorter OEM bolt. Install 6 of the OEM bolts in their original location and install the longer Rekluse bolt in the lower right hand corner. See following pictures for reference.

⚠ CAUTION

Failure to install the OEM clutch cover bolts back in their proper location can result in damage to your motorcycle.

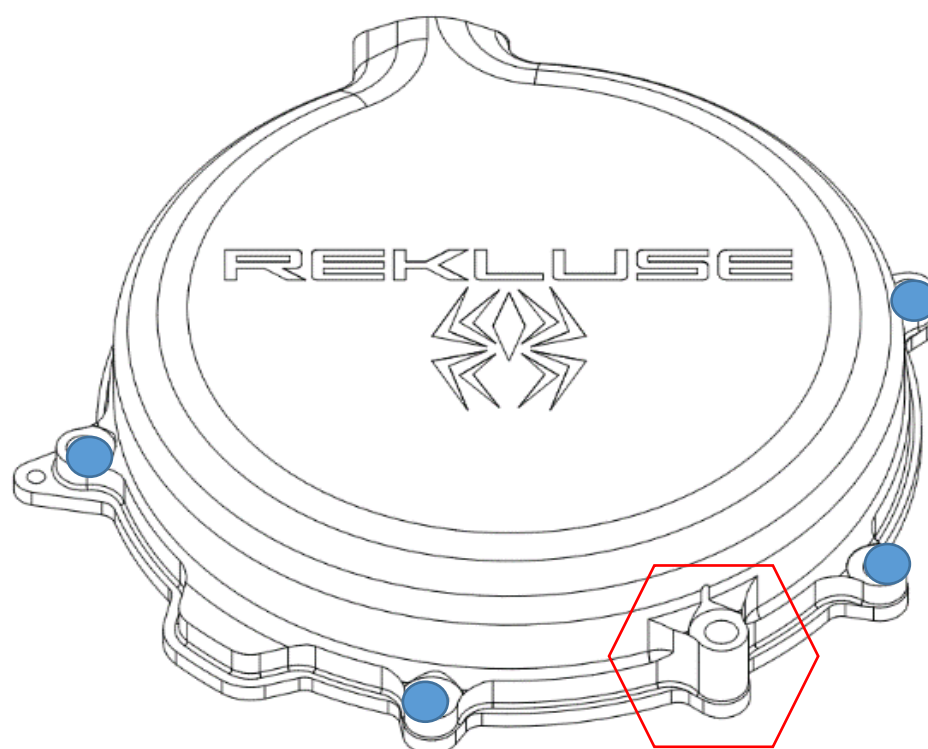
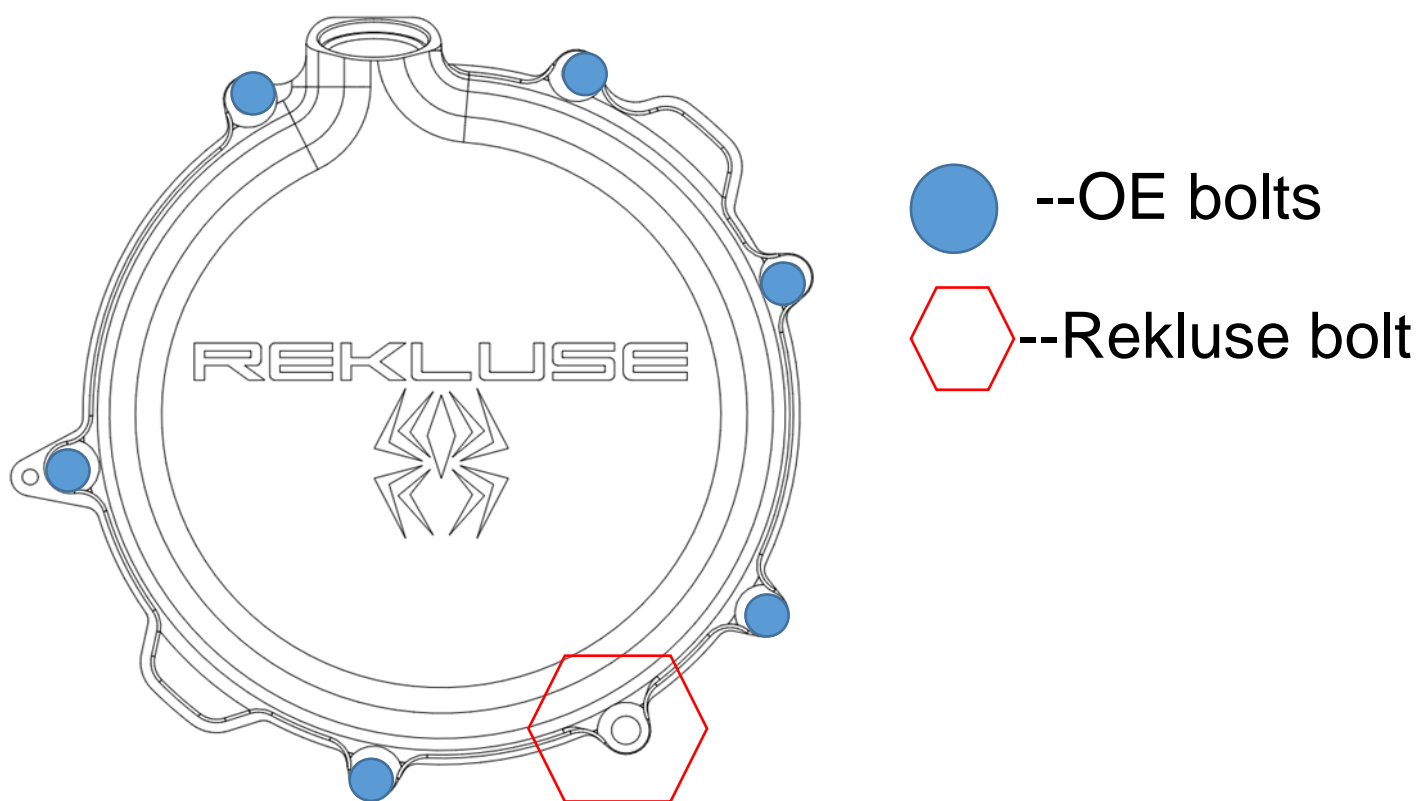

10. Install the Rekluse clutch cover by lightly tightening the cover bolts in a star pattern. Tighten bolts in small increments before torquing the cover bolts to OE specifications. If your bike has an oil plug, transfer the OE oil plug to the new Rekluse clutch cover.

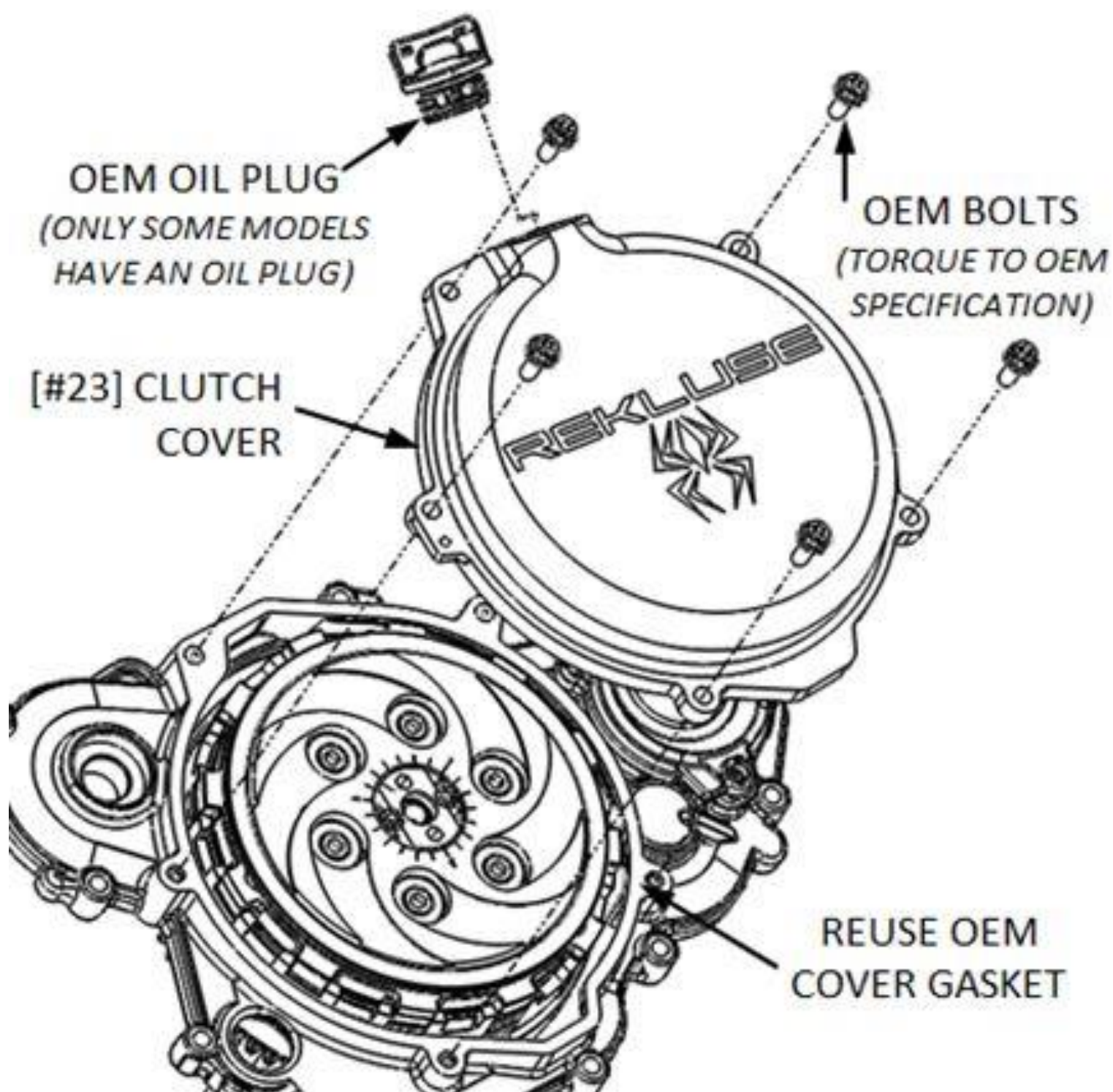

SLAVE CYLINDER INSTALLATION

Installing the new Rekluse slave cylinder takes several steps. Please read the entire section before beginning the process to ensure you have the right equipment and clutch fluid needed for the replacement. Rekluse recommends wearing gloves and safety glasses for the install.

⚠ CAUTION

During the bleed and assembly, note that there is a small ball bearing installed in the slave piston with a small amount of grease. When installing the Rekluse slave cylinder, make sure the ball is in place and has not come loose.

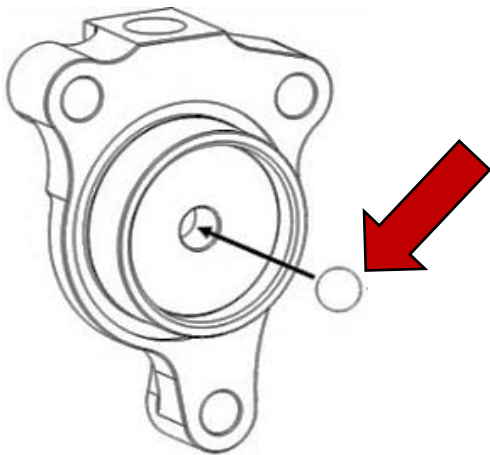

Step 1: Bleed the new slave cylinder

This step prepares the new slave cylinder for installation. Bleed the cylinder on a workbench or an area away from the bike.

1. Using a 4 mm Allen wrench, turn the adjuster screw counterclockwise so that the top O-ring is visible under the adjuster screw.

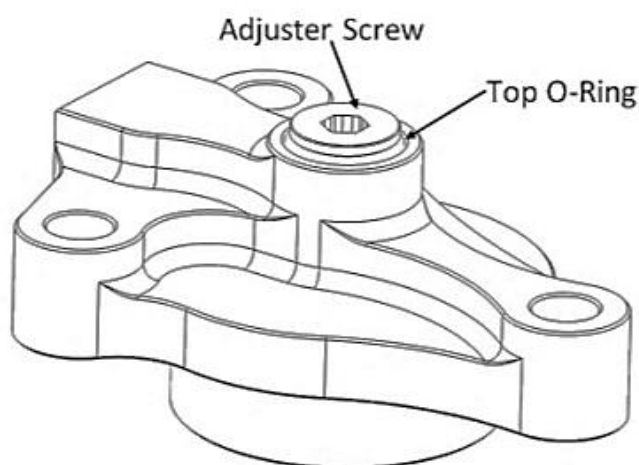

2. Use your thumbs to compress the piston until it bottoms out, then release it.

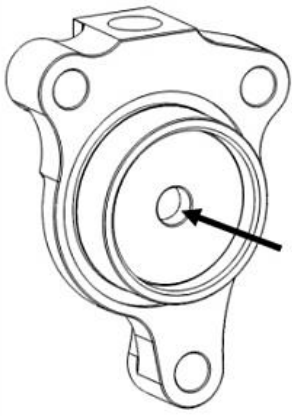

3. Pour the recommended clutch fluid into the slave cylinder port.

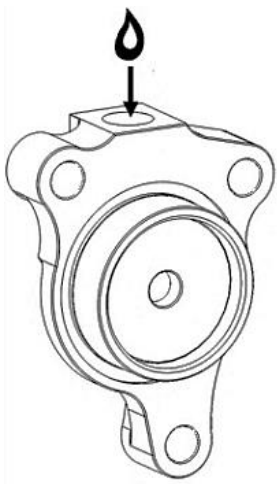

⚠ CAUTION

Be sure to use the correct clutch fluid. Check the cap of the clutch master cylinder to determine which clutch fluid to use. Failure to use the correct fluid will result in seal damage and/or failure.

4. Use a 4 mm Allen wrench to turn the adjuster screw clockwise until it bottoms out and the O-ring is no longer visible. Keep the fluid topped off as you go.

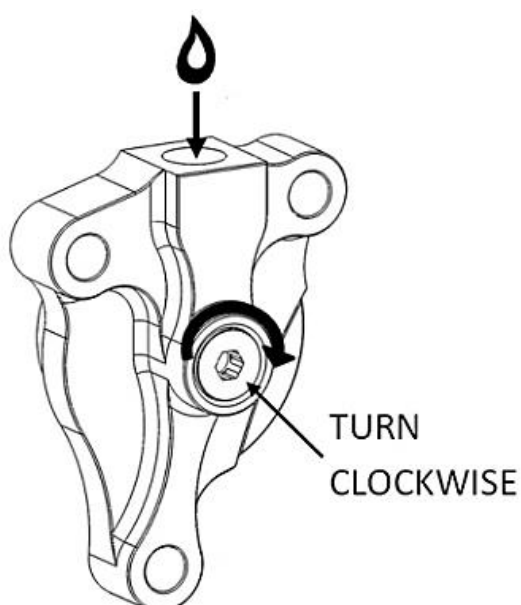

5. Use the wrench to turn the adjuster screw counterclockwise back to the initial position, with the top O-ring visible. Keep the fluid topped off as you go.

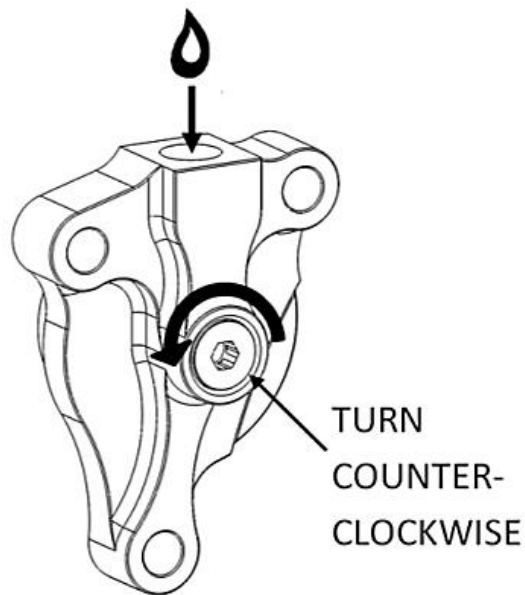

6. Use your thumbs to compress the piston again until it bottoms out while looking for air bubbles.

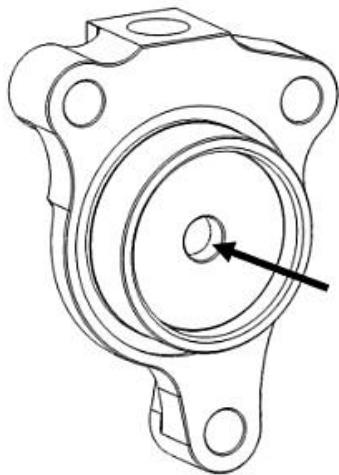

⚠ CAUTION

When compressing the piston, fluid can shoot out from the slave cylinder port. Be sure to wear eye protection.

7. Repeat steps 3 - 6 until there are no air bubbles coming out in the fluid when the piston is compressed.
8. When the bleeding is complete, turn the adjuster screw counterclockwise so that the top O-ring is visible.
9. Compress the piston until it bottoms out, and top off with fluid.

10. Check that the ball bearing is still in place. Stand the Rekluse slave cylinder in an upright position (so the fluid does not spill) until it is needed in the next step.

Step 2: Replace OE slave cylinder

In this step, the OE slave cylinder is replaced with the Rekluse slave cylinder. Work quickly when performing the following steps. This method retains the fluid inside the line, and makes the final bleeding step easier.

1. Stand the bike up and lean it on its kickstand, or place it on a suitable bike stand.

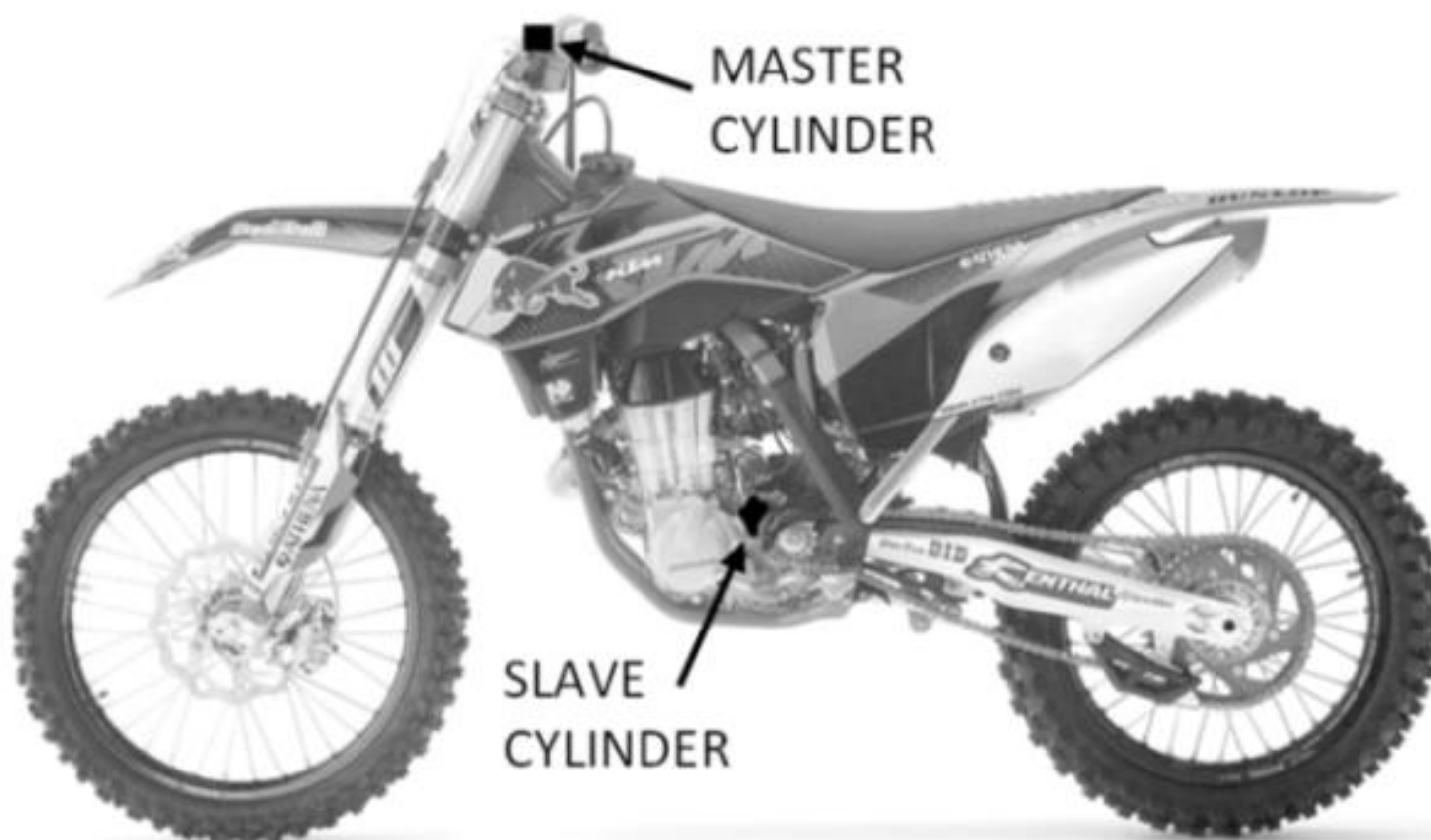

NOTICE

Some 2017 FE450/501 slave cylinders have the banjo bleeder bolt and some have the straight fluid line. Follow the instructions based on the type of fluid line on your bike.

2. On the left side of the bike, while leaving the OE slave cylinder bolted on the engine, use a wrench to remove the banjo bleeder bolt from the OE slave cylinder.

3. Remove the clutch fluid line and the 2 OE crush washers from the OE slave cylinder.

2017+ FE450/501:

- Remove the OE fluid line fitting.

4. Set the banjo bleeder bolt and the OE crush washer aside. They will not be reused.

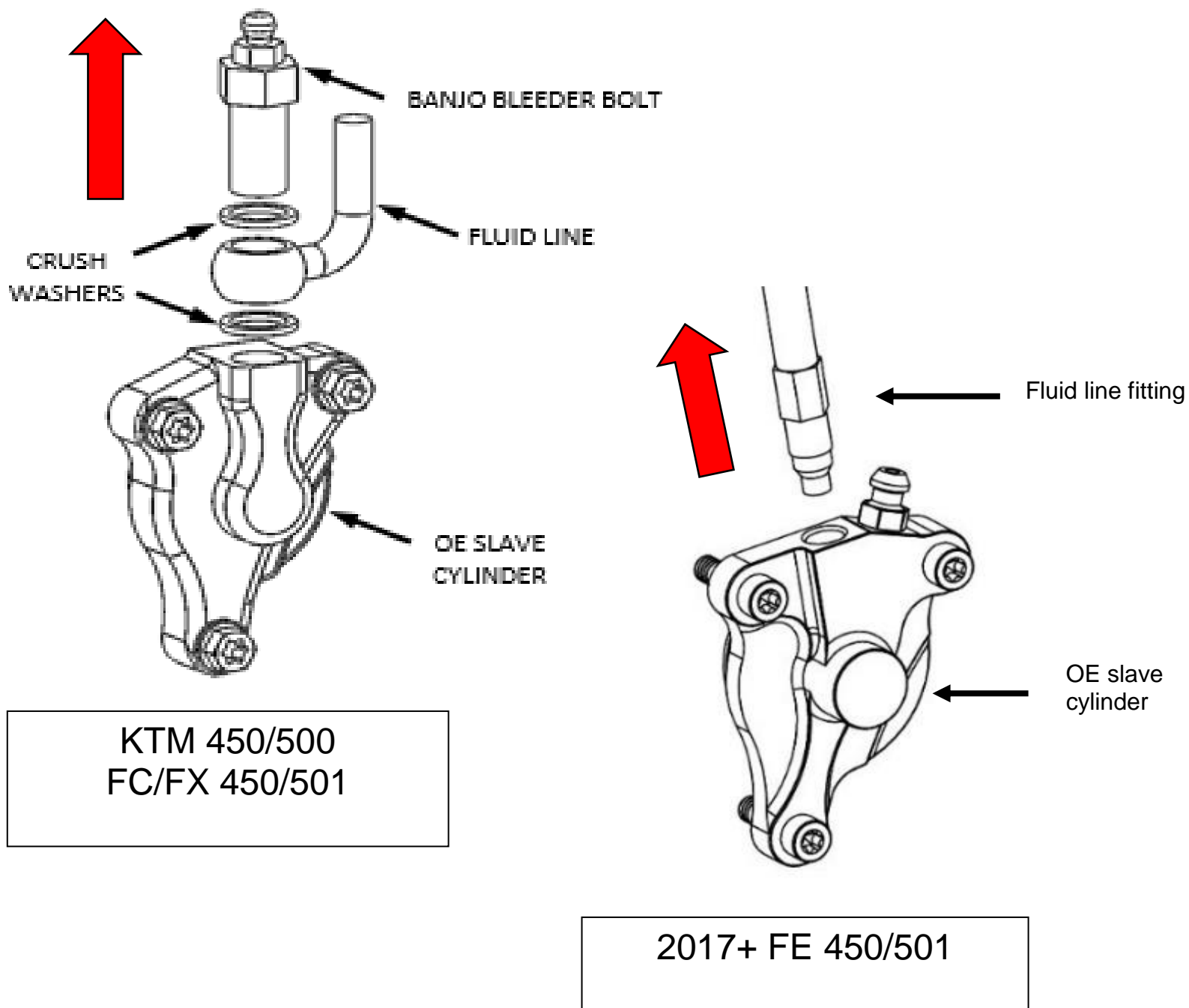

5. Attach the clutch fluid line to the Rekluse slave cylinder using the supplied banjo bolt and the 2 new crush washers from Rekluse. Make sure the clutch fluid line is between the 2 crush washers.

2017+ FE450/501:

- Attach the clutch fluid line directly to the Rekluse slave cylinder. You will not use the crush washers.

NOTICE

A quick transfer of the fluid line will result in less bleeding in the following steps.

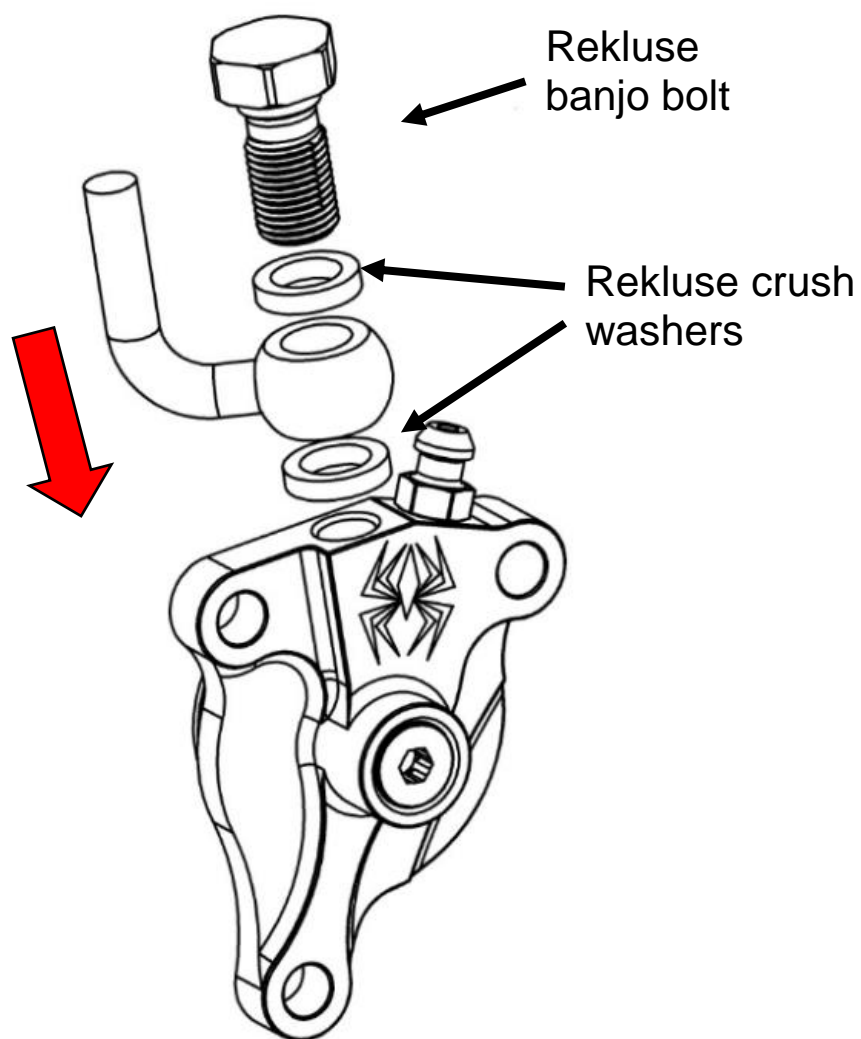

KTM 450/500
FC/FX 450/501

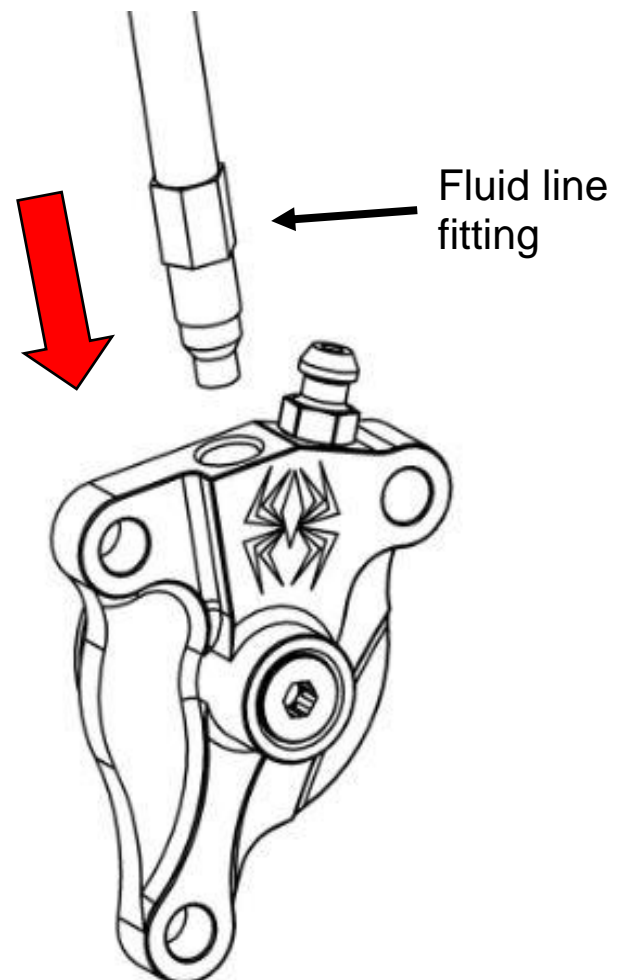

2017+ FE
450/501

6. Tighten the banjo bolt (or fluid line fitting) with your hand until snug. (You will torque it to spec once installed on the bike.)
7. Remove the cap and bladder from the clutch master cylinder.

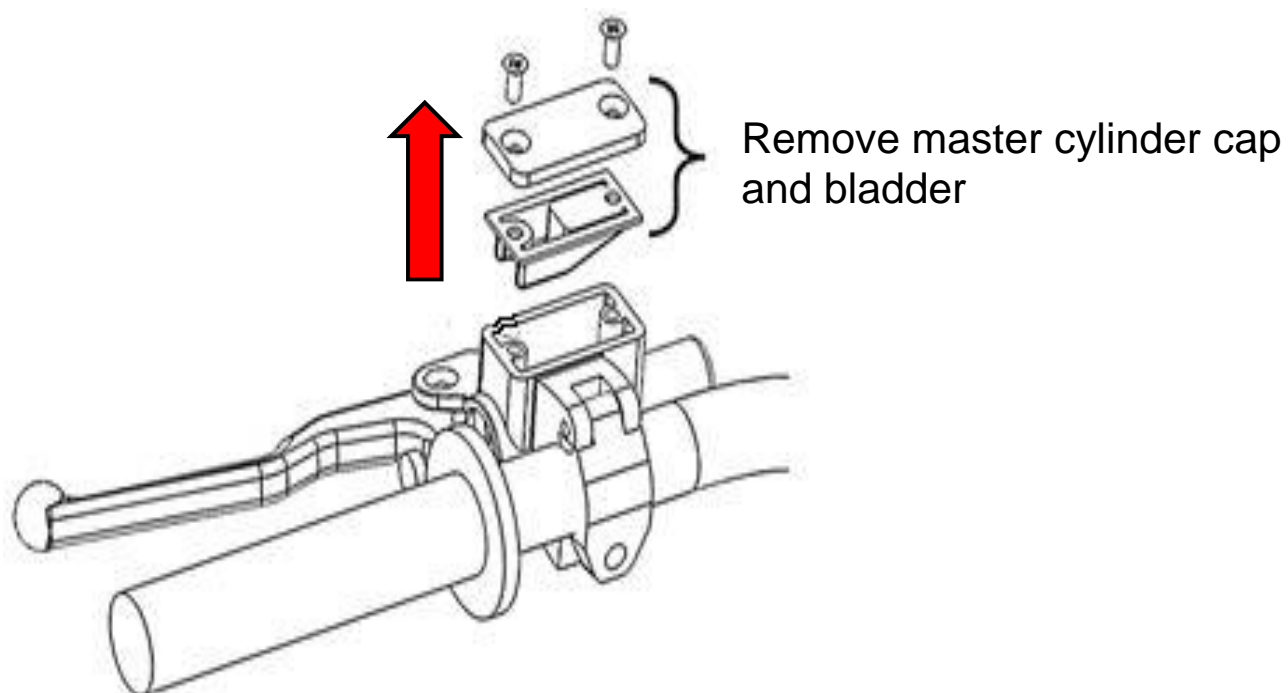

8. With the clutch fluid line attached to the Rekluse slave cylinder, remove the OE slave cylinder from the engine. Keep the OE bolts for reuse.

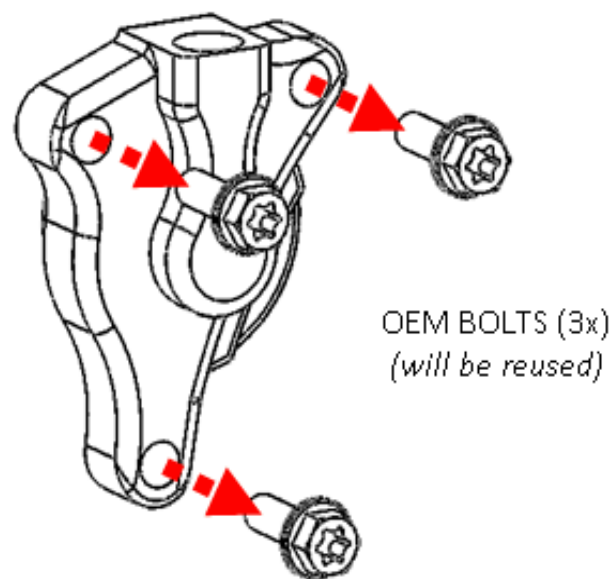

9. Mount the Rekluse slave cylinder to the engine using the OE bolts.

NOTICE

Some models have a piston diaphragm seal. DO NOT REUSE them if OE equipped.

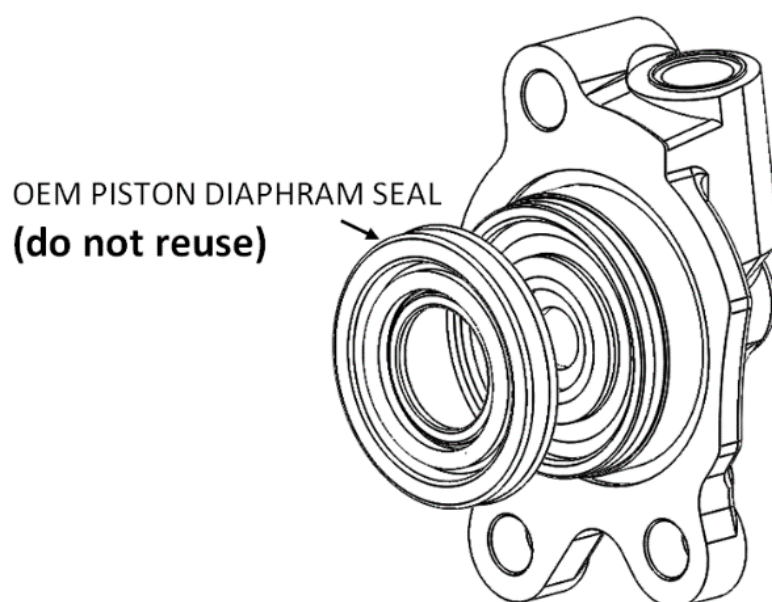

NOTICE

When installing case sealing O-ring seal (OEM or Rekluse supplied) ensure it is seated against slave cylinder flange.

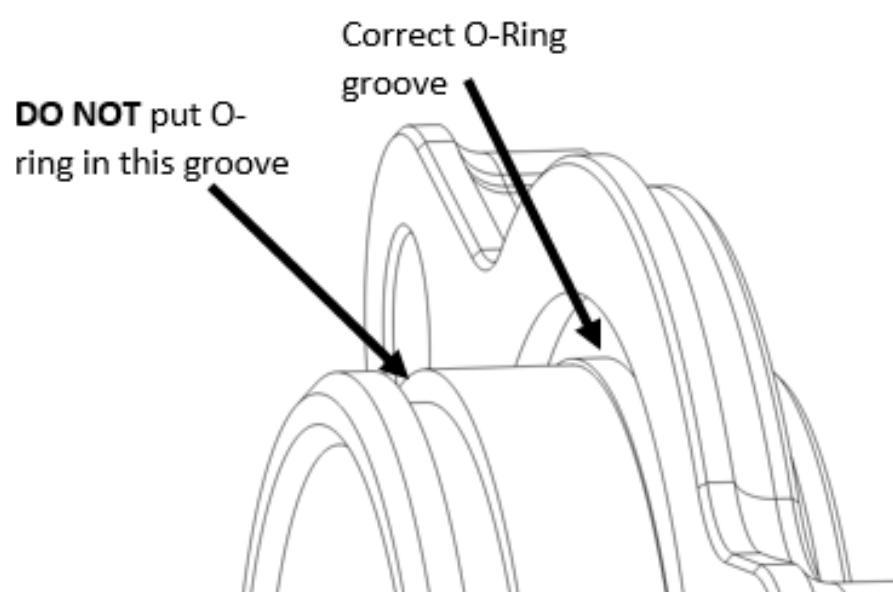

NOTICE

The Rekluse slave cylinder comes preassembled in the kit. If the parts become separated, assemble them in the following order: Rekluse slave cylinder, O-ring, then the supplied paper gasket.

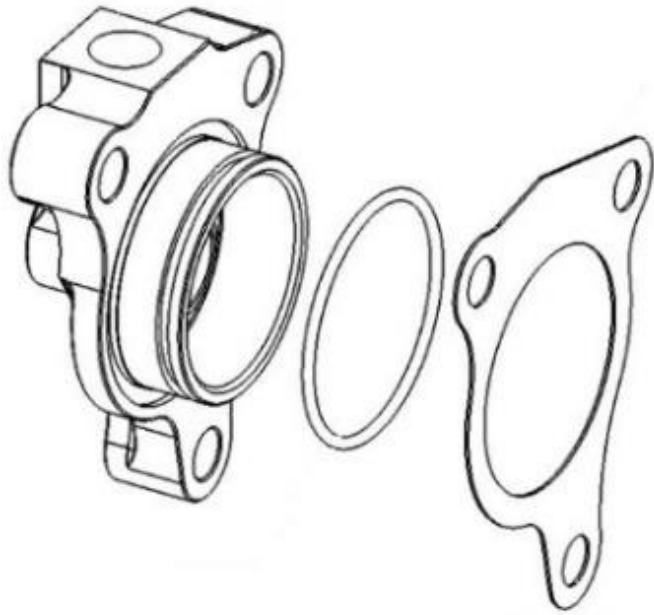

10. Torque the banjo bolt to 18 ft-lb (25 N-m) per OE specification.

- Optional: If you purchased the Rekluse Slave Guard accessory, install it now using the instructions in the kit.



11. Attach the supplied bleed tube to the banjo bolt port and loop it into a suitable catch bottle.

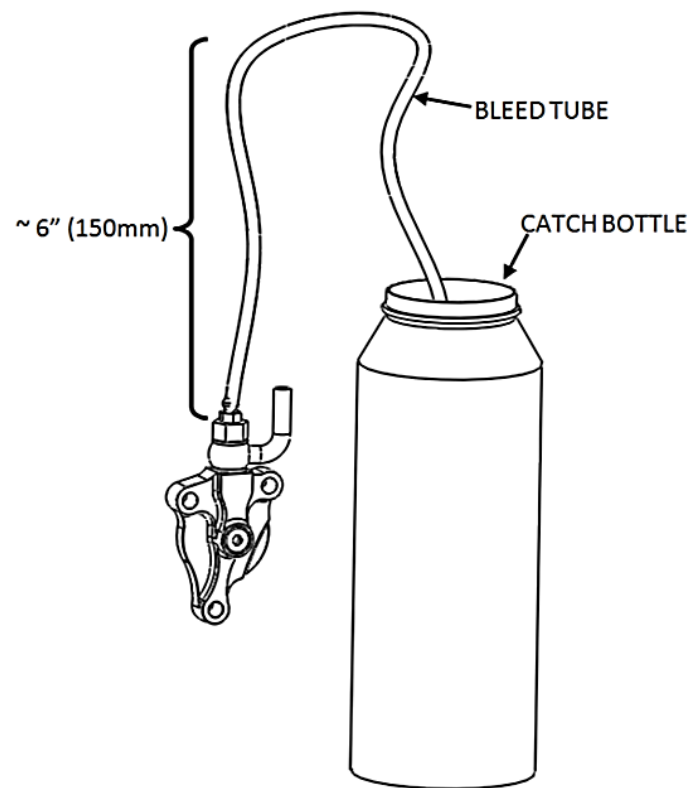

12. Pump the clutch lever 3-5 times then hold it against the bar/grip.

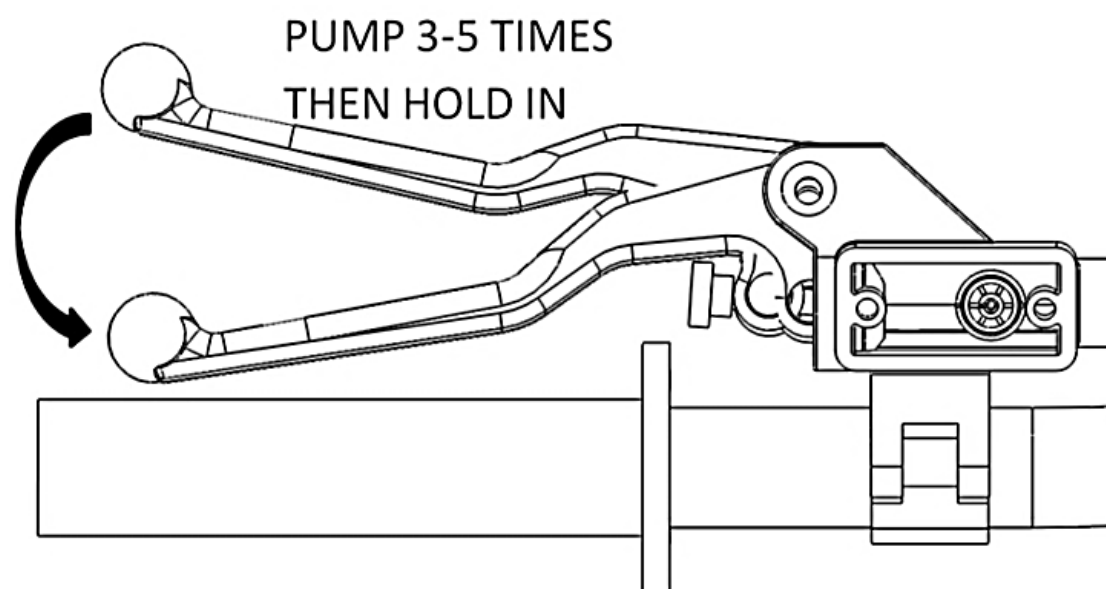

13. Using an 8mm wrench, open the bleed port. Air and fluid should come out of the bleed tube. Tighten the bleed port.

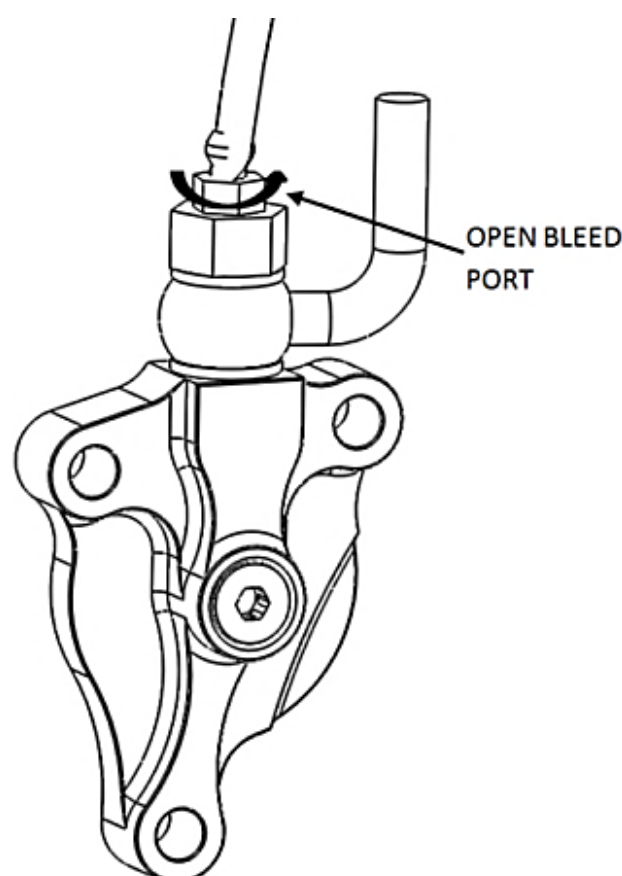

14. Slowly release the clutch lever and check the fluid level in the clutch master cylinder.

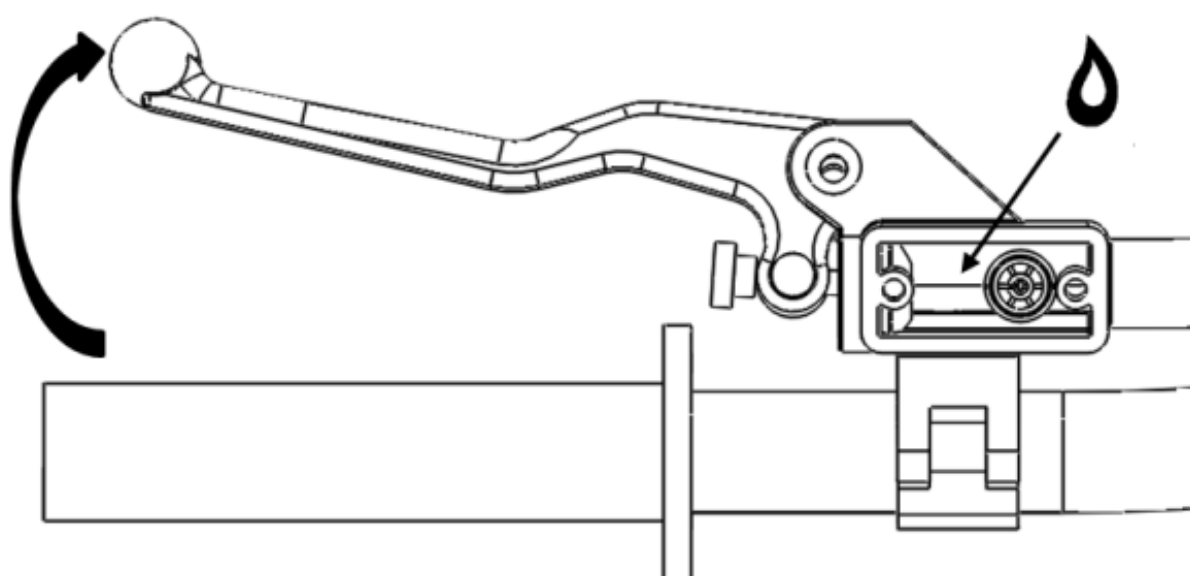

15. Repeat the previous 3 bleeding steps until air no longer comes out of the bleed port. Then, check that the clutch lever functions properly. Repeat the bleeding procedure if necessary.

16. Check that the clutch master cylinder is 75% full, then replace the cap and bladder on the clutch master cylinder.

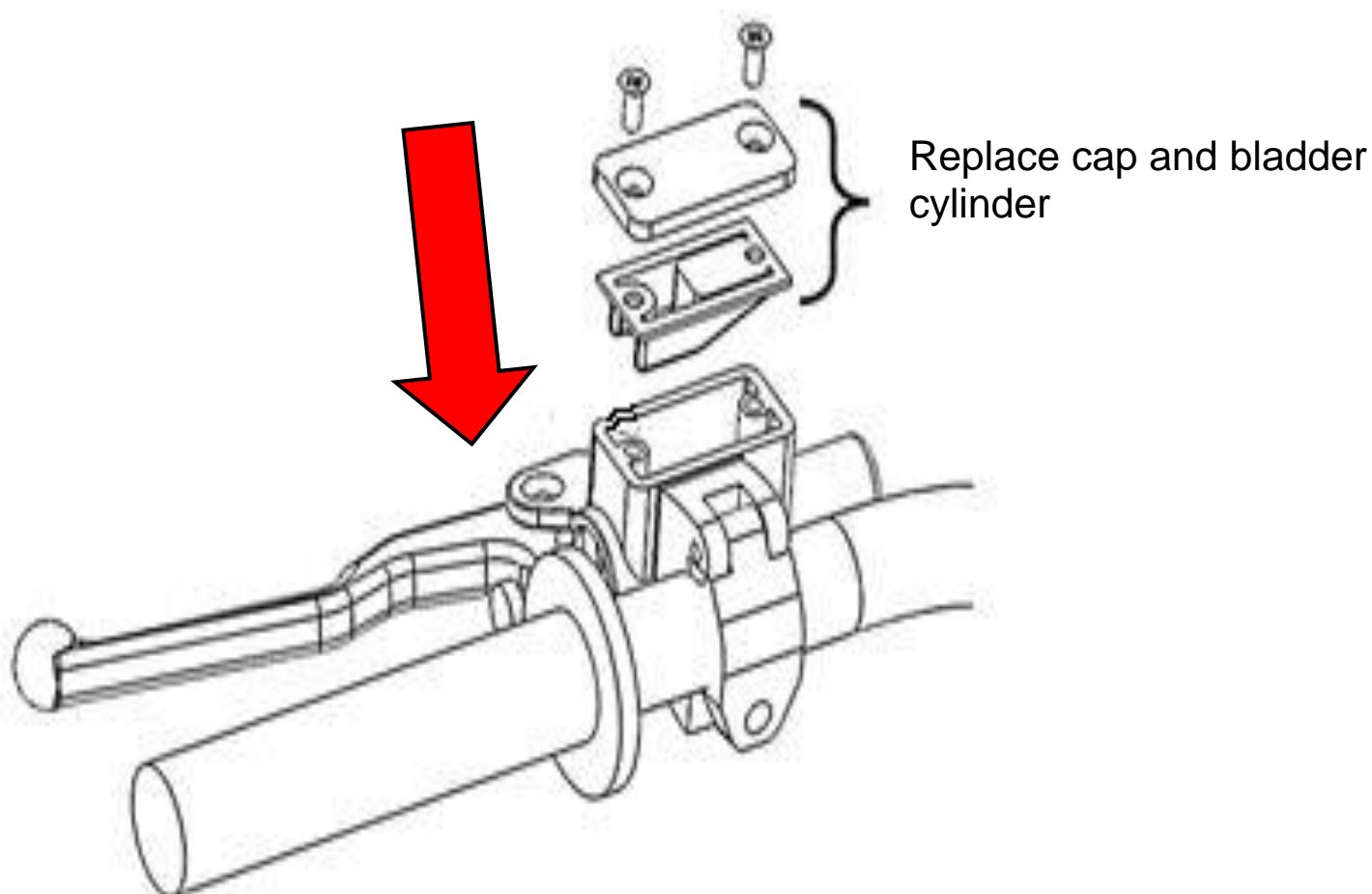

17. Remove the bleed tube and bottle, then torque the bleed screw to 150 in-lb (17 Nm).

18. Finally, replace the rubber dust cap over the bleeder screw.

SET THE INSTALLED GAP AND VERIFY BY CHECKING FREE PLAY GAIN

It is very important that you understand how to set the installed gap in your new clutch, and be able to verify the installed gap by checking Free Play Gain.

Setup, break-in, and rechecking the installed gap is **CRUCIAL**. Failure to properly maintain your installed gap can result in premature wear or failure of your clutch.

The “installed gap” is the free space in the clutch pack when the EXP disk is disengaged (collapsed). This gap allows the clutch to spin freely until the engagement RPM is reached and the EXP disk expands to close the gap and apply pressure to the pressure plate, which in turn drives the motorcycle forward.

The installed gap is what allows the auto function of the product to perform properly. Use the following steps to set the installed gap and check the Free Play Gain.

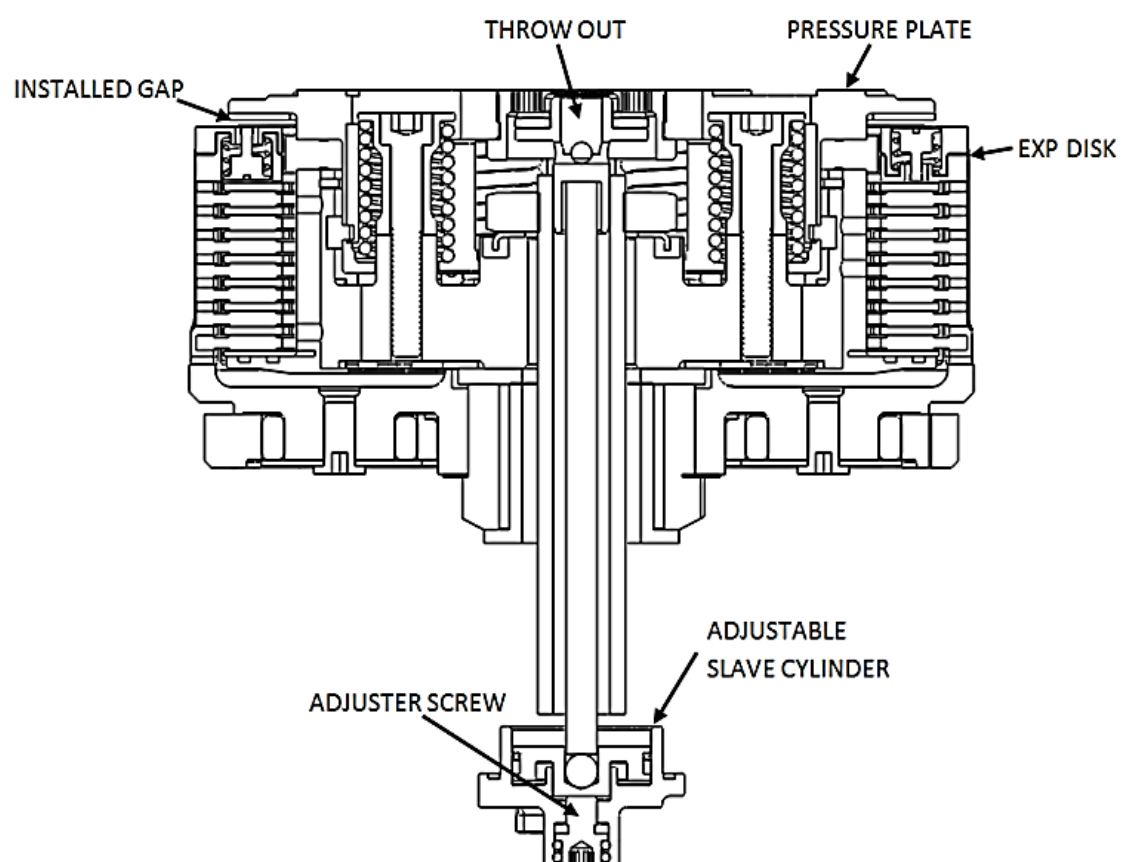

⚠ WARNING

Failure to check and verify Free Play Gain can cause failure or damage to this product. Setting the correct installed gap is critical for clutch performance.

Setting the installed gap and checking Free Play Gain is a 4-step process. It is important to follow each step to ensure that your new clutch functions as designed.

Step 1: Find the starting point

- a) With the bike standing up, locate the adjuster screw in the center of the adjustable slave cylinder.
- b) With the O-ring showing, use a 4 mm Allen wrench to turn the adjuster screw clockwise until it stops under light pressure. This is your “starting point.”

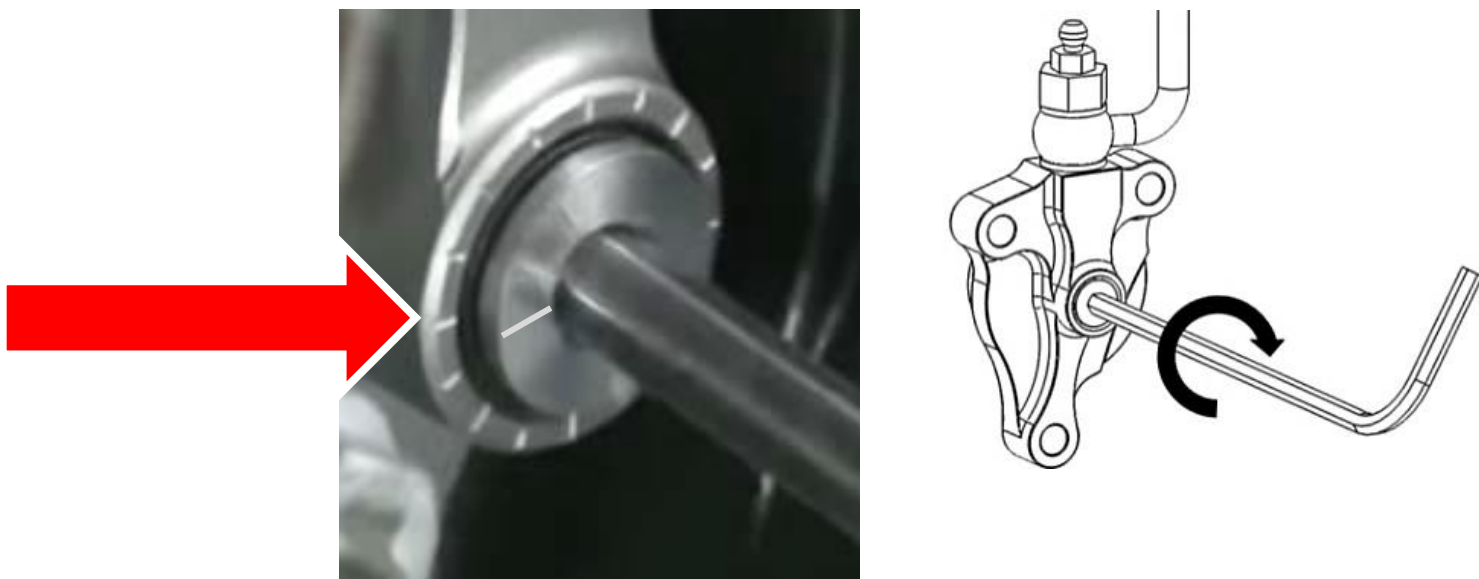

NOTICE

The resistance you feel is where the throw-out begins to lift the pressure plate. Finding the right starting point may take a few tries, but you will feel a noticeable change in turning effort once you reach that point. Stop when you feel the pressure increase. The “starting point” will change as the clutch pack wears over time.

- c) Once you have found the starting point, note the position of the Allen wrench using the tick marks on the slave cylinder housing and the small etch mark located on the screw. You will begin here to adjust the installed gap.

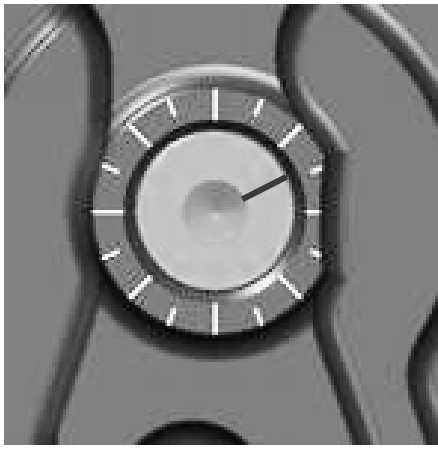

Use the tick marks on the cylinder and the etch mark on the screw to remember the starting point for adjusting the gap.

d) Use a 4 mm Allen wrench to turn the adjuster screw clockwise 1 full turn + 2 tick marks from your starting point. **This may NOT be your final setting**, but it is a beginning adjustment for finding the correct setting.

e) Continue with Step 2 to check for Free Play Gain.

⚠ CAUTION

Do not ride your bike without the adjusting the installed gap. You will not be able to disengage the clutch until you set the installed gap.

Step 2: Learn how to check Free Play Gain

Feeling Free Play Gain with the beginning adjustment to the slave cylinder aids in learning to recognize Free Play Gain.

If you are familiar with Free Play Gain, you can skip to Step 3 - "Break-in the new clutch." If Free Play Gain is new to you, follow the instructions below to help you learn this important step. You can also view the video entitled "How to Check Free Play Gain" on our website at www.rekluse.com/support/videos.

Free Play Gain is different from the "normal" free play you are used to with your stock clutch. With the Rekluse auto clutch, Free Play Gain is the result of the EXP disk expanding and lifting the pressure plate to engage the clutch.

The correct installed gap is verified by observing and feeling the increased free play movement in the clutch lever. This extra movement is called “Free Play Gain.”



Lever with “slack”
removed

Lever position around
5.000 RPM

Free Play Gain
1/8”-1/4” (3 mm-6 mm)
lever movement

If there is too much Free Play Gain, the installed gap is too small.

- The bike may drag and stall because it has difficulty disengaging the clutch.
- It may also be difficult to shift.
- Too much Free Play Gain will not hurt the clutch, but it will negatively affect clutch performance.

With too little or no Free Play Gain, the installed gap is too large. This means when the EXP is fully expanded it does not lift the pressure plate.

- The clutch may slip and make the bike seem like it is losing power.
- The bike may not move forward even though the engine RPM increases as if the clutch lever is slightly pulled.
- Too little Free Play Gain will cause the clutch system to burn up.

Optimal Free Play Gain yields 1/8”-1/4” (3-6 mm) of clutch lever movement, measured at the ball end of the lever. This measurement at the lever correlates to achieving the ideal installed gap.

TWO WAYS TO CHECK FOR FREE PLAY GAIN

The following steps explain **2 ways** to check Free Play Gain. One way uses the rubber band Rekluse includes in the clutch kit, and one uses your hand. You can use either method to check for Free Play Gain.

Rekluse recommends that you begin with the rubber band method first to check for Free Play Gain and then learn the hand method. The rubber band will help you learn how to recognize Free Play Gain until you are comfortable with the hand method. Learning to check Free Play Gain by hand effectively and comfortably can make it easy to check Free Play Gain every time you ride.

The Rubber Band Method

Use the rubber band method for the initial set up. It can also be used before each ride until you feel comfortable checking the Free Play Gain using the hand method.

▲ WARNING

BEFORE YOU BEGIN, verify that the bike is in NEUTRAL before checking Free Play Gain. Failure to do so may result in the bike lurching forward, and loss of control and/or injury may result.

A Rekluse auto-clutch can make your motorcycle appear to be in neutral when in gear, even when the engine is running and clutch lever released.

Motorcycles equipped with a Rekluse auto-clutch can move suddenly and unexpectedly and cause riders to lose control. To avoid death, serious injury, and/or property damage, always sit on the motorcycle to start it.

a) Before you begin, place the bike in **NEUTRAL**, start the engine and let it warm up for 2-3 minutes to idle down and warm the engine oil.

b) Stretch the included rubber band between your thumbs, then place the top end of the rubber band on the outer end of the left handlebar grip.



c) While holding the top end of the rubber band against the handlebar, stretch the band downward, then loop it through itself.



d) Pull the band through the loop, then attach it to the outside end of the clutch lever. This will take up the initial free play (slack) and put the lever in a position to detect the Free Play Gain.



- e) While still in **NEUTRAL**, quickly rev the engine between 5,000-7,000 RPM (1/2 to 3/4 throttle), then let it return to idle. Notice the movement in the clutch lever when the engine is revved. This is your Free Play Gain.

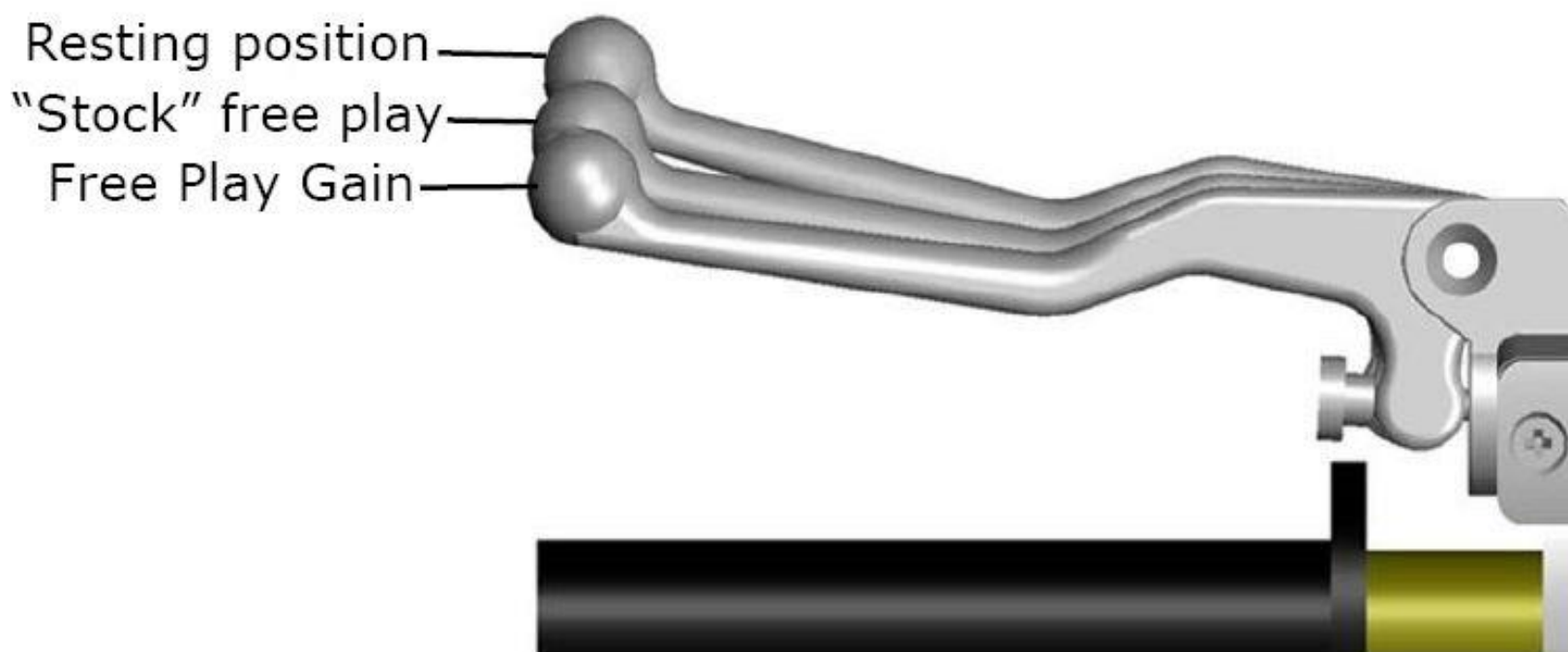

NOTICE

It is very important the motor returns to idle before revving the engine again or Free Play Gain will not be correct.

- f) When the bike returns to idle, rest your hand across the clutch lever. Rev the engine again to 5,000-7,000 RPM so you can observe the movement while feeling for Free Play Gain with your hand.

The Hand Method

Use the hand method to check Free Play Gain before the start of every ride for optimum performance and longevity of your new clutch.

- a) Before you begin, place the bike in **NEUTRAL**, start the engine and let it warm up for 2-3 minutes to idle down and warm up the engine oil.

- b) With the bike at idle, apply enough pressure to the clutch lever to take up the initial free play (slack) in the clutch lever.

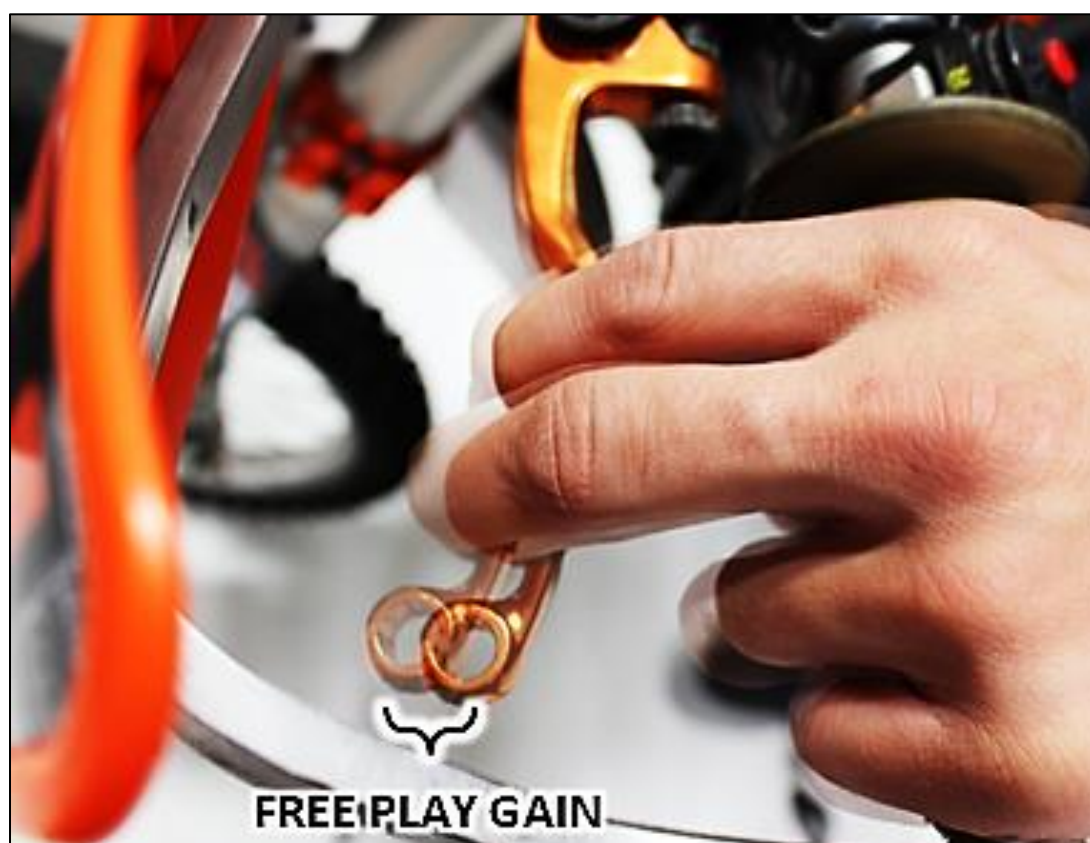

- c) While still in **NEUTRAL**, continue to apply light pressure and quickly rev the engine between 5,000-7,000 RPM (1/2 to 3/4 throttle), then let it return to idle. Notice the movement in the clutch lever when the engine is revved. This is your Free Play Gain.
- d) When the bike returns to idle, rev the engine between 5,000-7,000 RPM a second time to feel the Free Play Gain again.
- e) Continue with Step 3 to break-in the new clutch.

Step 3: Break-in the new clutch

Once you install your new clutch, it is important to break it in. A series of roll-on starts are used to break in the clutch. Follow these procedures for breaking in your clutch and any time new friction disks, EXP bases, Teflon pads, or wedges are installed.

⚠ WARNING

Failure to follow the break-in procedure and oil screen inspection process could cause motor oil delivery failure which can result in motor failure, serious injury, or death.

Break-in Procedure	Number of times
<p>Rev Cycles:</p> <ol style="list-style-type: none">1. Place the bike in NEUTRAL.2. With your hand off the clutch lever, rev the engine 10 times, being sure to let it return to idle between each rev cycle. <p>① N ② ③ ④ ⑤</p>	<p>10 rev cycles</p>
<ol style="list-style-type: none">3. With the engine still running, pull in the clutch lever, then click the bike into 1st gear. Slowly release the clutch lever. The bike should stay in place or have a slight amount of forward creep. <p>① N ② ③ ④ ⑤</p> <ol style="list-style-type: none">4. With the bike idling in first gear, slowly apply throttle to begin moving.5. Without using the clutch lever, accelerate moderately to approximately 5,000 RPM to fully lock up the clutch and come to a complete stop. Repeat 10 times.	<p>10 roll-on starts</p>

NOTICE

If the engine wants to stall or the creep is excessive, the idle may be too high or the installed gap may be too small. Make necessary adjustments before proceeding.

6. Without using the clutch lever, start in 2nd gear, then accelerate moderately to approximately 5,000 RPM and come to a complete stop. Repeat 10 times.



10 roll-on starts

7. Place the bike in **NEUTRAL** and recheck Free Play Gain.

8. Continue to step 4 to adjust the installed gap until the Free Play Gain of the clutch lever is 1/8" (3 mm).



Recheck Free Play Gain and adjust the installed gap

NOTICE

Your clutch pack will expand with heat, so final adjustment to Free Play Gain should be made when the bike is warm. Remember not to ride without sufficient Free Play Gain.

CAUTION

Do not perform 3rd gear starts with this product. Starting in 3rd gear will burn up the clutch and decrease the performance of this product in a short amount of time.

Step 4: Adjust the installed gap and Recheck Free Play Gain

Once you have learned how to check Free Play Gain, you need to finish adjusting the installed gap, then recheck the Free Play Gain until the clutch lever moves only 1/8" (3 mm). The gap is adjusted by turning the slave cylinder screw.

- a) With the bike running and in **NEUTRAL**, locate the adjuster screw in the center of the adjustable slave cylinder.
- b) Use a 4 mm Allen wrench to turn the adjuster screw clockwise 1 tick mark from the last setting, then recheck Free Play Gain.



Tick marks are located on the slave cylinder, and an etch mark is on the screw. If you need to re-position the Allen wrench, you can use these marks for reference.

- c) Continue to adjust the slave cylinder 1 tick mark at a time until optimal Free Play Gain is achieved.
- d) Refer to the following pictures and chart in the next section for additional adjustment information.
- e) The Free Play Gain will change as the clutch pack wears over time.
- f) Checking the Free Play Gain is easy and indicates when the install gap needs adjusting.

FREE PLAY GAIN ADJUSTMENTS

Make each adjustment in small increments - one tick mark at a time. After each adjustment, recheck Free Play Gain until you achieve the optimal 1/8" (3 mm) of clutch lever movement.



Symptom	Reason	Solution
<ul style="list-style-type: none"> • Clutch lever moves in too far (too much Free Play Gain) • Clutch has excessive drag or stalls • It is difficult to fully override the clutch with the lever 	<p>Installed gap is too small</p>	<p>Turn the adjuster screw clockwise 1-2 marks to increase the installed gap and decrease Free Play Gain. Recheck Free Play Gain.</p>
<ul style="list-style-type: none"> • Clutch lever only moves slightly or does not move at all (too little Free Play Gain) • Clutch slips • Bike seems to lose power 	<p>Installed gap is too large</p>	<p>Turn the adjuster screw counterclockwise 1-2 marks to reduce the installed gap and increase Free Play Gain. Recheck Free Play Gain.</p>

MAINTENANCE

To keep your clutch performing at its best, perform regular maintenance on your bike and clutch.

- Keep up with regular oil changes as per the bike manufacturer's recommendations. Clutch performance and longevity depend on oil quality.

Oil recommendations can also be viewed under Tech Tips on our website at www.rekluse.com/support/videos/atv-mc-support-videos.

- Inspect all of your clutch parts for signs of wear or excessive heat, and replace components as necessary. Clutch wear is dependent on the riders use.

Maintenance Protocol	Maintenance Intervals
Check and verify Free Play Gain	Every ride
Inspect all clutch parts for excessive wear or heat. Replace as needed.	Refer to OE service manual
Change oil, inspect and clean oil screen	Refer to OE service manual

- The OE spring ring can be optimized based on the wear and height of the clutch pack. See the attached Setup Sheet for the spring ring optimization table to adjust the spring ring.
- Measuring the clutch pack and/or the EXP disk can help determine if the components need replacing. See the Setup Sheet for the specific clutch pack measurements.

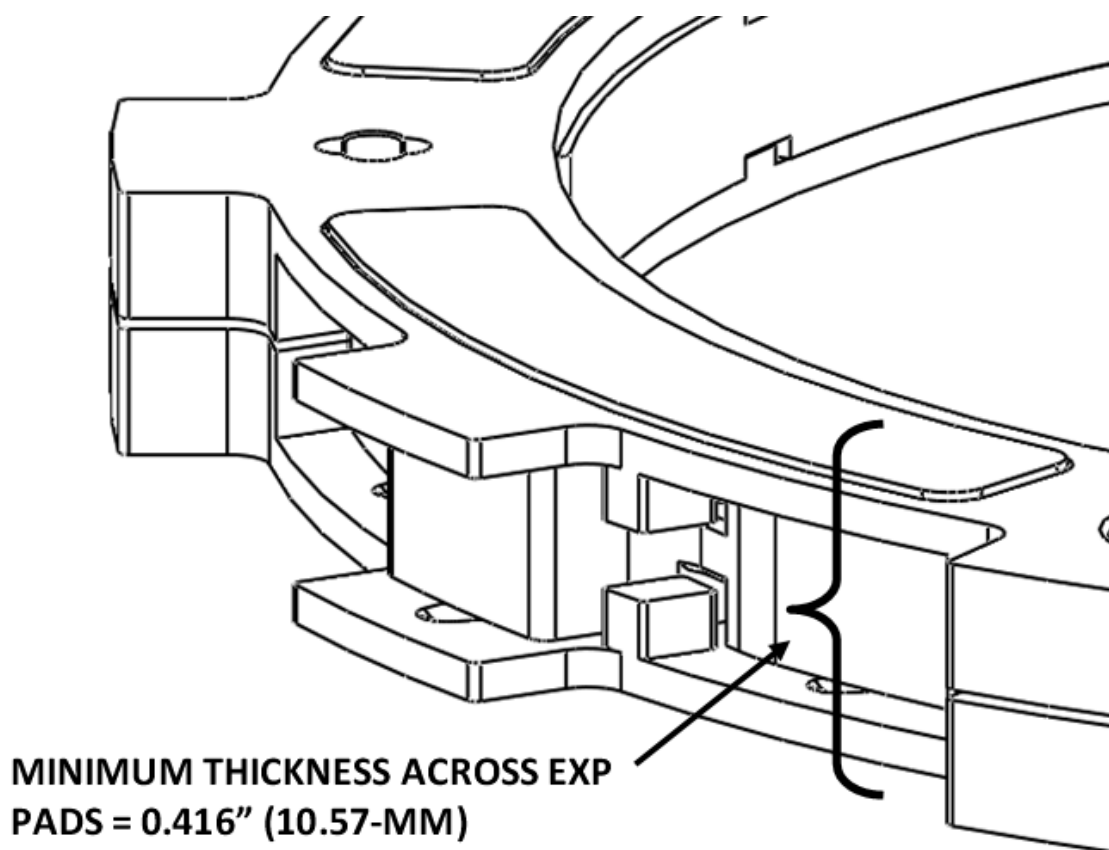

- Inspect the dampers, and replace them if you feel any movement between the two hubs. Refer to the section on inspecting the dampers for more information.
- Maintain adequate Free Play Gain. Check before every ride and adjust if necessary.
- Repeat the break-in procedure anytime you replace the EXP bases, Teflon pads, EXP wedges, or frictions disks. Always soak friction disks or EXP bases in oil for at least 5 minutes before installing.
- Replace friction disks if they measure below specifications listed on the attached Setup Sheet or if the disks are glazed and/or burnt.
- Replace the drive plates if they show signs of excessive heat.

Disk inspection examples

When inspecting the clutch pack, the following pictures can be used as a reference. **These are best viewed in color by viewing this install document from www.rekluse.com/support.**

Drive Plates – If the clutch pack is getting high amounts of heat, purple, blue, or black color can be seen on the drive plate teeth. See pictures below. Not all drive plates look the same and may look different than pictured.

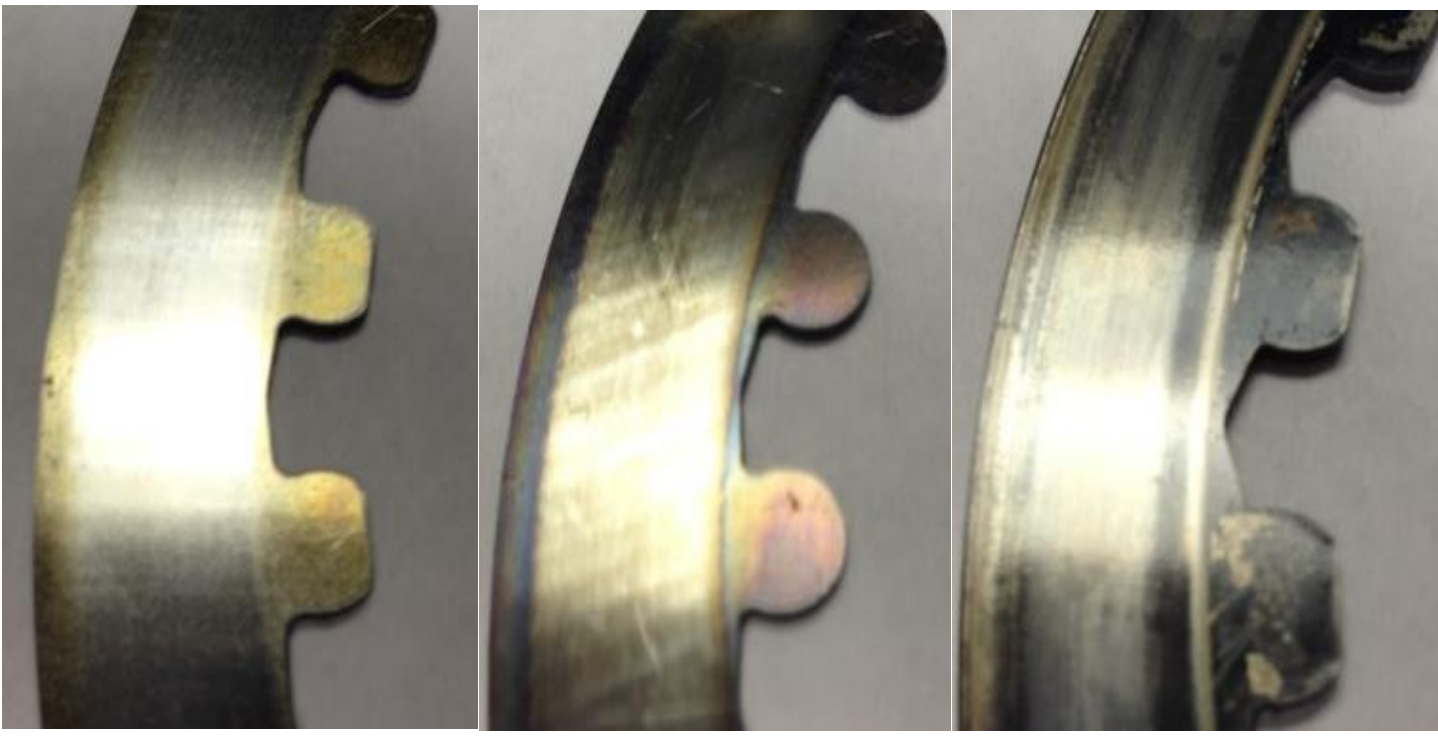

Normal Heat

High Heat
(Blue)

Excessive Heat
(Black)

Friction Disks – Due to the dark color of the friction material, the friction disks will appear almost black as soon as they are put in oil. During inspection, look for glazing of the friction material. Glazing will appear shiny and feel like glass, even after oil is cleaned from the friction disk. Not all friction disks look the same and may look different than pictured.



Normal
Friction



Glazed
Friction

TROUBLESHOOTING

Performance issues

If you find yourself adjusting the slave cylinder to fix Free Play Gain or drag, the clutch disks might be worn. Excessive heat or clutch slip can cause premature clutch failure as well. Once extreme temperatures are reached, irreversible damage will occur.

- Inspect all of your clutch parts for signs of wear or excessive heat, and replace components as necessary. Clutch wear is dependent on the riders use.
- Measuring the clutch pack and/or the EXP disk can help determine if the components need replacing. See the attached Setup Sheet for the specific clutch pack measurements.

Clutch noise

Although it is harmless, some bike models may have “squeal” or “chatter” coming from the clutch at low RPM as it engages. Clutch squeal is caused by the clutch components vibrating as the clutch engages and can become more audible as the clutch gets hot. Adjusting the installed gap will NOT affect clutch squeal or chatter.

For bike models that have clutch squeal or chatter here are some recommendations to reduce or eliminate it:

- Change the oil: For optimal clutch performance Rekluse recommends using fresh, clean oil that **meets JASO-MA** oil rating requirements. Dirty or old oil can make the clutch more likely to squeal or chatter.

EXP TUNING OPTIONS

Adjusting the engine idle speed to match your engagement setting is important and greatly affects the overall feel of how the EXP disk engages. To prevent freewheeling and maximize engine braking, set the idle so there is a slight amount of drag while the bike is idling in gear and warmed up. The idle should not be so high as to move the bike forward in gear with the throttle closed. However, with a small opening of the throttle the bike should move forward.

You can tune the engagement RPM of the EXP disk by changing the spring configuration. The EXP disk comes set with the recommended “**Medium**” setting from Rekluse. Use the following steps to change the springs. It is **NOT necessary** to disassemble the EXP halves to change springs!

Configuration chart

ENGAGEMENT SETTING	SPRING CONFIGURATION			
	450/500/501 4-stroke*	250/300 2-stroke (Pre 2017)	250/300 2-stroke (2017+)	250/350 EXC-F/XCF-W
Low	6 Blue	6 Silver	6 Steel	6 Silver
Medium	3 Blue & 3 Gold	3 Silver & 3 Red	3 Silver & 3 Steel	3 Silver & 3 Red
High	6 Gold	6 Red	6 Silver	6 Red

NOTICE

***Some 450/500/501 4-stroke models may be set by dealers to an idle lower than the manufacture recommendation. For idle speeds at 1650 RPM ± 50 refer to the following table**

ENGAGEMENT SETTING	450/500/501 SPRING CONFIGURATION
Low	6 Silver
Medium	3 Silver & 3 Red
High	6 Red

Changing the springs

1. Using a flat-blade screwdriver, push the $\frac{1}{4}$ turn pin in far enough to clear the opposite side of the EXP to unlock the pin.

2. With the pin still pushed past the base, turn 90° to remove the pin and spring.

3. Remove the remaining 2 pins and springs from the same side of the EXP base.

4. Drop a new spring into the spring slot on the base, then add the $\frac{1}{4}$ turn pin.

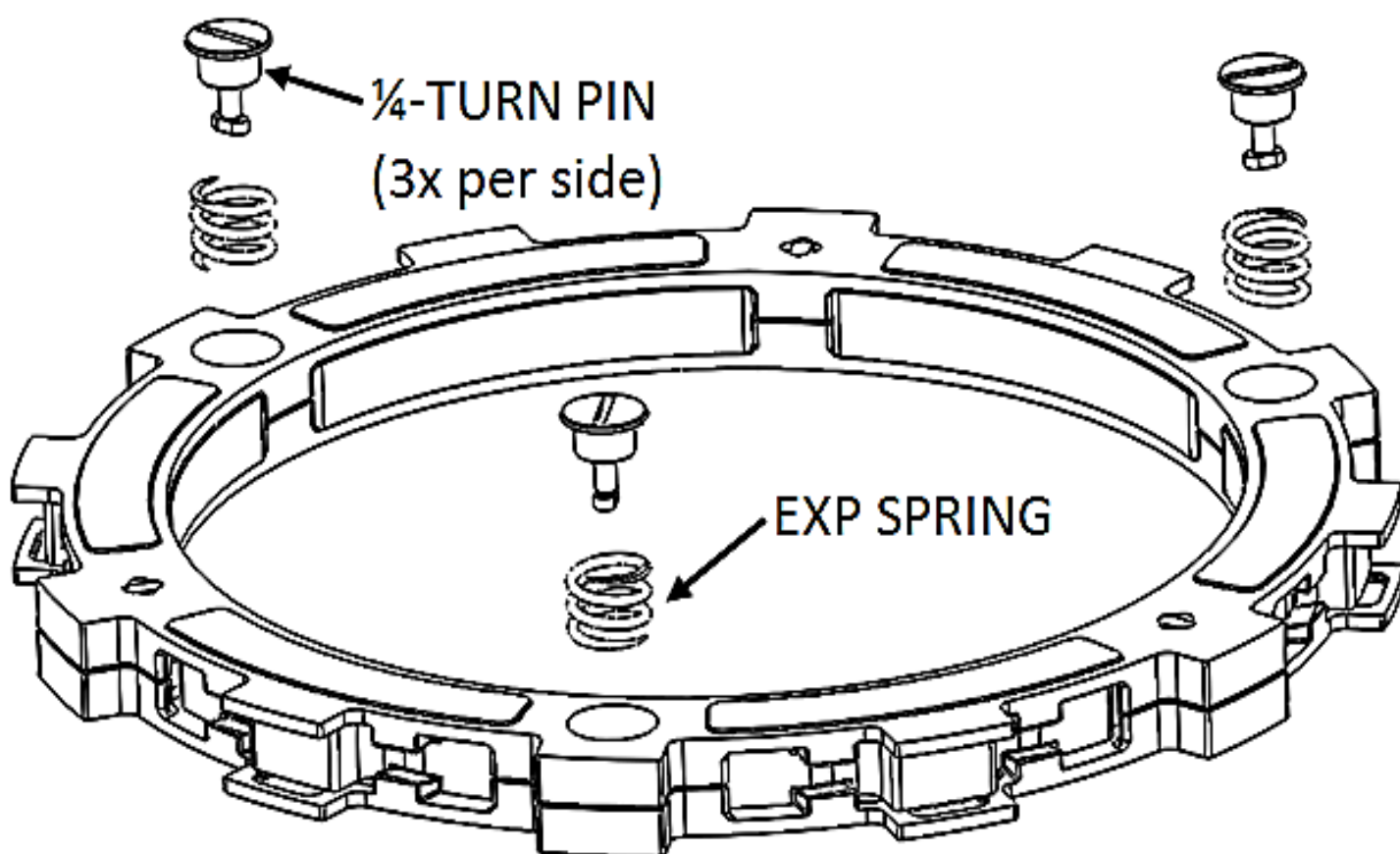

5. Push the turn pin in far enough to clear the base, then turn 90° and release the pin. The pin should sit almost flush with the EXP base.

6. Flip the EXP friction disk over, and repeat on the other side depending on engagement preference.

7. If you need to disassemble the EXP disk, you can watch the video on our website under Tech Tips at <http://www.rekluse.com/support/videos>.

⚠ CAUTION

If you disassemble the EXP, the Teflon pads may fall out or be stuck to the ramp surfaces of the EXP bases. Take care to ensure all pads are correctly placed into wedge pockets using gentle pressure to avoid damage to the pad surfaces before reassembling the EXP. Properly seated pads will be secured in place once the EXP is reassembled. Operating the clutch without the pads in place will cause part damage or failure.

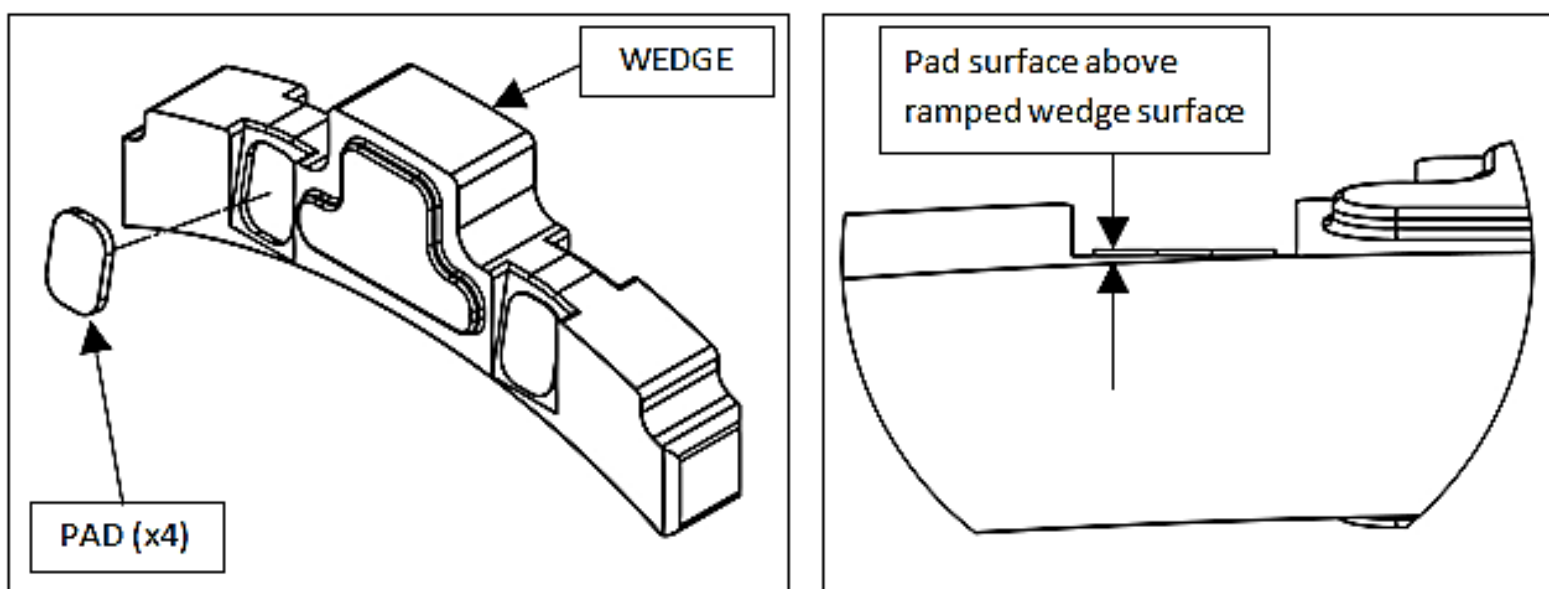

BUMP-STARTING

If your bike needs to be bump-started due to a dead battery or any other reason, follow the steps below to quickly bump-start your bike.

1. Turn the adjustable slave cylinder counterclockwise to collapse the gap until no resistance is felt.
2. Bump start the bike. The clutch will function like a manual clutch at this point, but the clutch will not be fully over-ridable at high RPMs.
3. Once the bike is started, readjust the installed gap.

NEED ADDITIONAL HELP?

Website

www.rekluse.com/support

Frequently asked questions

www.rekluse.com/faq

Support Videos

www.rekluse.com/support/videos

Phone

(208) 426-0659

Technical Support

Contact Technical Support for questions related to product installation, tuning, and performance.

Technical Support hours:

Monday thru Friday: 8:00 a.m. - 5:00 p.m.

Mountain Time zone

Email: tech@rekluse.com

Customer Service

Contact Customer Service for additional product information, orders, and returns.

Customer Service hours:

Monday thru Friday: 8:00 a.m. - 5:00 p.m.

Mountain Time zone

Email: customerservice@rekluse.com





Auto Clutch TROUBLESHOOTING GUIDE

Rekluse Troubleshooting Guide Terms

Free Play Gain – The additional movement of the clutch lever under slight pressure as the RPMs are raised from idle to approximately 5000 RPM. Free Play Gain should only be checked in neutral as per the instructions.

Worn Friction Plates – Will be thinner than the factory spec

Overheated Friction Plates – Sometimes referred to as glazed. Most of the time measure within spec, but the surface will look darker than new and the friction surface will be smooth like glass. The steel drive plates will also show signs of bluing or darkness

Squeal – Chirping noise under acceleration, or take off

Chatter/Shutter – Vibration or surge under acceleration as the clutch engages

Drag – When stopped or idling in gear, the bike will try pulling, or on a stand the wheel will spin

Chain Slap – Drag at idle, in gear, causing the chain to slap noisily against the swing arm

Low RPM Slip – Considered engagement slip and will make the initial clutch engagement soft

High RPM Slip – Occurs above half throttle while accelerating, as the engine RPMs raise little or no power is transmitted to the rear wheel resulting in a loss of forward drive causing excessive clutch heat

Rekluse troubleshooting chart located on back of this page

Note: The “possible fixes” contained in the chart below are listed in the order of things to try first for each “symptom”

Core EXP 3.0 & EXP 3.0 Troubleshooting Chart		
Symptom	Possible Cause	Possible Fix
Drag or Stalling	Clutch break-in	Complete the recommended clutch break-in
	Transmission oil	Change the oil if it's not a clean high quality JASO MA certified oil
	Excessive “Free Play Gain”	Re-adjust the installed gap and re-check “Free Play Gain”
	Center clutch nut too tight	Re-torque the center clutch nut if it is binding when spun in neutral
	EXP engagement adjustment	Change the EXP setting to a higher engagement setting
	Worn or glazed friction disks	Replace friction disks (Rekluse or OEM disks recommended)
Low RPM slip	No “Free Play Gain”	Re-adjust the installed gap and re-check “Free Play Gain”
	Modified motor	Replace wedges with a heavier set if slightly modified
		If running Core EXP - Replace the pressure plate springs with a heavier set if highly modified
		If running EXP – upgrading to Core EXP is recommended
	Worn or glazed friction disks	Replace friction disks (Rekluse or OEM disks recommended)
Tall Bike gearing	Replace wedges with a heavier set if the gearing is taller than stock	
High RPM slip	No “Free Play Gain”	Re-adjust the installed gap and re-check “Free Play Gain”
	Modified motor	If running Core EXP - Replace the pressure plate springs with a heavier set if highly modified
		If running EXP – upgrading to Core EXP is recommended
	Pressure plate springs	Be sure the Rekluse springs are being used
		Inspect the springs, if they are out of spec replace
Worn or glazed friction disks	Replace frictions disks (Rekluse or OEM disks recommended)	
Squeal or Chatter	Transmission oil	Change the oil if it's not clean high quality JASO MA certified oil. Over-used oil may cause squeal or chatter
	Clutch basket	Replace the basket and/or cushions if they are worn (Rekluse basket recommended if available for your model)
		The Rekluse basket is known to eliminate most squeal or chatter, even if no wear is present (Not available for all models)
No clutch override	Excessive “Free Play Gain”	Re-adjust the installed gap and re-check “Free Play Gain”
Chain Slap	Adjust idle	Adjust idle closer to the engagement point of the clutch so there is less delay in clutch engagement
	EXP engagement setting	Raise the EXP engagement setting and adjust the idle accordingly

SETUP SHEET 198-7913095

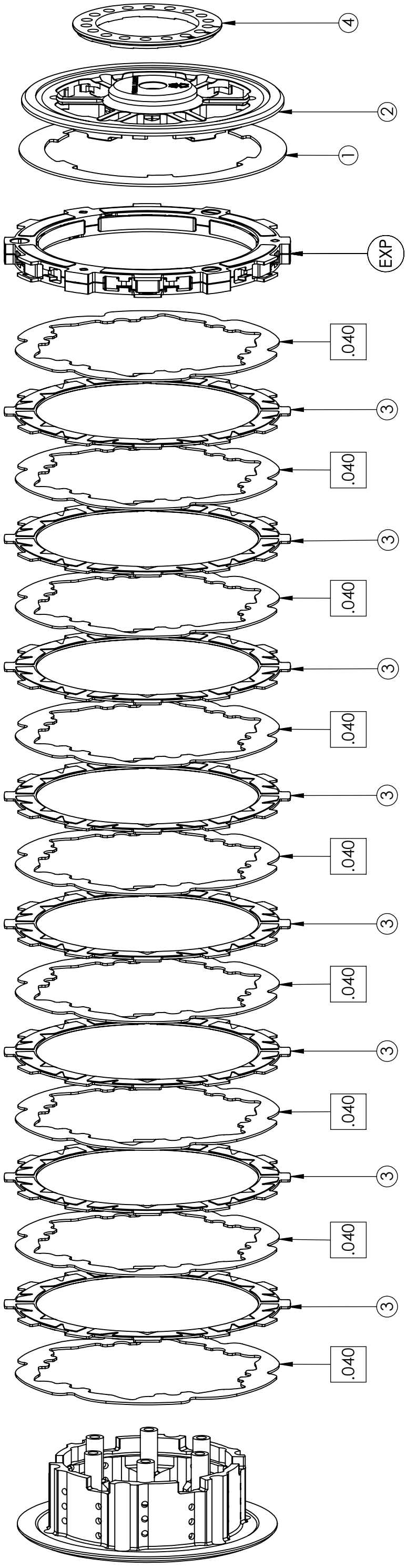

ITEM NO.	DESCRIPTION	QTY.
1	LINING PLATE [.048"/1.2mm THICK]	1
2	PRESSURE PLATE	1
.040	TEC DRIVE PLATE [.040"/1mm THICK]	9
3	TORQDRIVE FRICTION DISK	8
4	OEM Spring Ring	1
EXP	EXP 3.0 BASE - KT350	2

The OEM spring ring has different settings to account for variances in the clutch pack and wear. The optimal setting depends on the thickness of the clutch pack.

In general, MORE preload on the spring results in LESS clamping force, which in turn provides a lighter lever pull and less aggressive clutch performance.

LESS preload on the other hand provides MORE clamping force, a heavier clutch pull, and more aggressive clutch performance.

See the "Spring Ring Optimization Table" for recommended optimized setting based on clutch pack thickness.

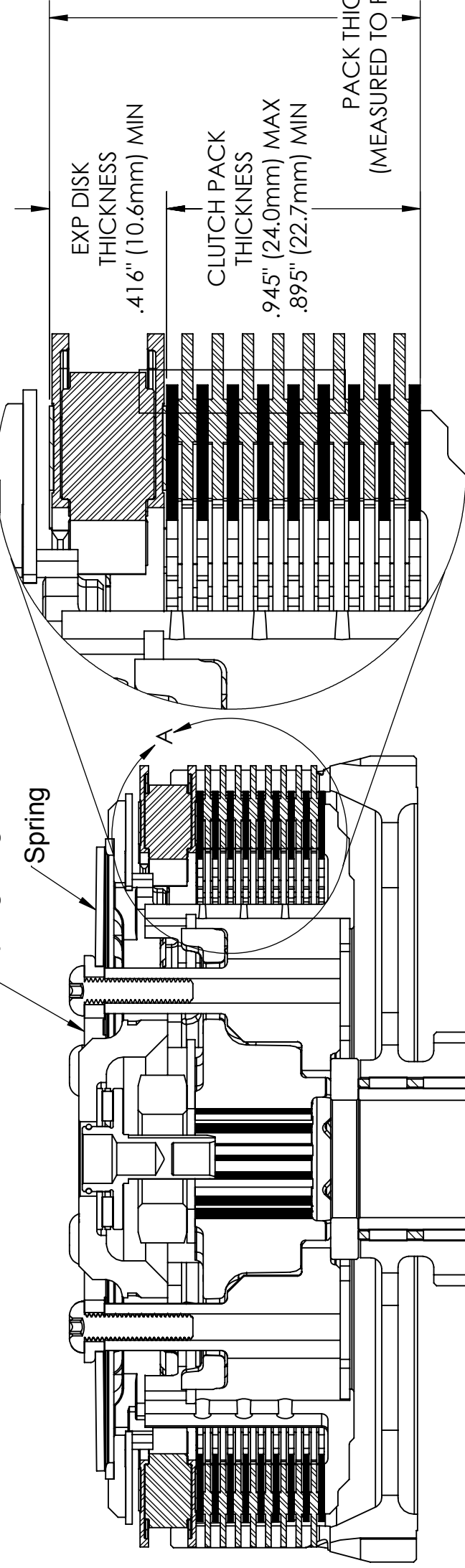

PACK THICKNESS [IN/mm]	SPRING RING SETTING
>1.352 (>34.3)	III OR Z
1.341-1.351 (34.0-34.3)	II OR Y
1.311-1.340 (33.3-34.0)	I OR X

PACK THICKNESS
(MEASURED TO PAD ON EXP)