



# **INSTALLATION & USER'S GUIDE**

RadiusCX for KTM 85

Doc ID: 191-7951A  
Revision: 110821

# **TABLE OF CONTENTS**

OVERVIEW .....	2
INSTALLATION TIPS .....	3
TOOLS NEEDED.....	3
INCLUDED PARTS .....	4
BIKE PREP & DISASSEMBLY .....	5
INSTALL THE CLUTCH PACK .....	7
PRESSURE PLATE INSTALLATION.....	11
SLAVE CYLINDER INSTALLATION .....	13
BLEED THE CLUTCH LINE .....	18
CHECK FREE PLAY GAIN .....	21
Step 1: Find the starting point .....	21
Step 2: Learn how to check Free Play Gain .....	23
Two Ways to Check for Free Play Gain .....	24
The Rubber Band Method.....	24
The Hand Method.....	26
Step 3: Break-in the new clutch .....	27
Step 4: Adjust the installed gap.....	29
FREE PLAY GAIN ADJUSTMENTS .....	30
EXP TUNING OPTIONS .....	31
Changing the springs .....	31
BUMP-STARTING .....	33
MAINTENANCE.....	33
Clutch wear .....	33
Clutch parts .....	34
Preventive Maintenance.....	34
NEED ADDITIONAL HELP?.....	36

## **OVERVIEW**

This kit replaces many of the OE (Original Equipment) or “stock” clutch parts. These parts are designed specifically for your motorcycle to ensure optimal performance.

- This kit will replace all the OE frictions and drive plates with a Rekluse thin friction EXP clutch pack.
- OE center clutch hub, pins, and pressure plate components are replaced with Rekluse Core components.

# INSTALLATION TIPS

- Read the separate included Safety Information document before operating the vehicle with the product installed.
- Read this entire document before performing any steps.
- If you install this product for a customer or another person, instruct them to read the **Safety Information** document and the **Installation and User Guide** before operating the bike with the product.
- Protect eyes and skin – wear safety glasses and work gloves.
- Lay the motorcycle on its left side when replacing the clutch. This makes the clutch work easier and eliminates the need to drain the oil. Catch any fuel that may drain from the bike.
- Use the torque values listed in the instructions. Otherwise, use the torque specifications found in your OE service manual.
- For optimal clutch performance Rekluse recommends using fresh, clean oil that **meets JASO-MA** oil rating requirements. Rekluse offers Factory Formulated Oil™ developed specifically for Rekluse products. Rekluse Factory Formulated Oil is a perfect complement to any OEM or aftermarket wet clutch. Visit [www.rekluse.com](http://www.rekluse.com) to learn more.

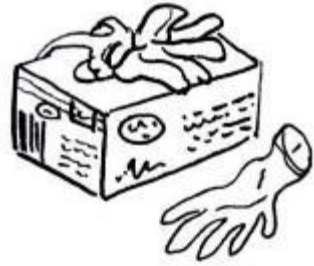

## TOOLS NEEDED

- 8 mm socket
- 24 mm socket
- Channel-lock pliers
- Hammer
- Spring puller
- Torque wrench (in-lb & ft-lb, or N-m)
- 4 mm hex bit/socket
- Screwdriver

# INCLUDED PARTS

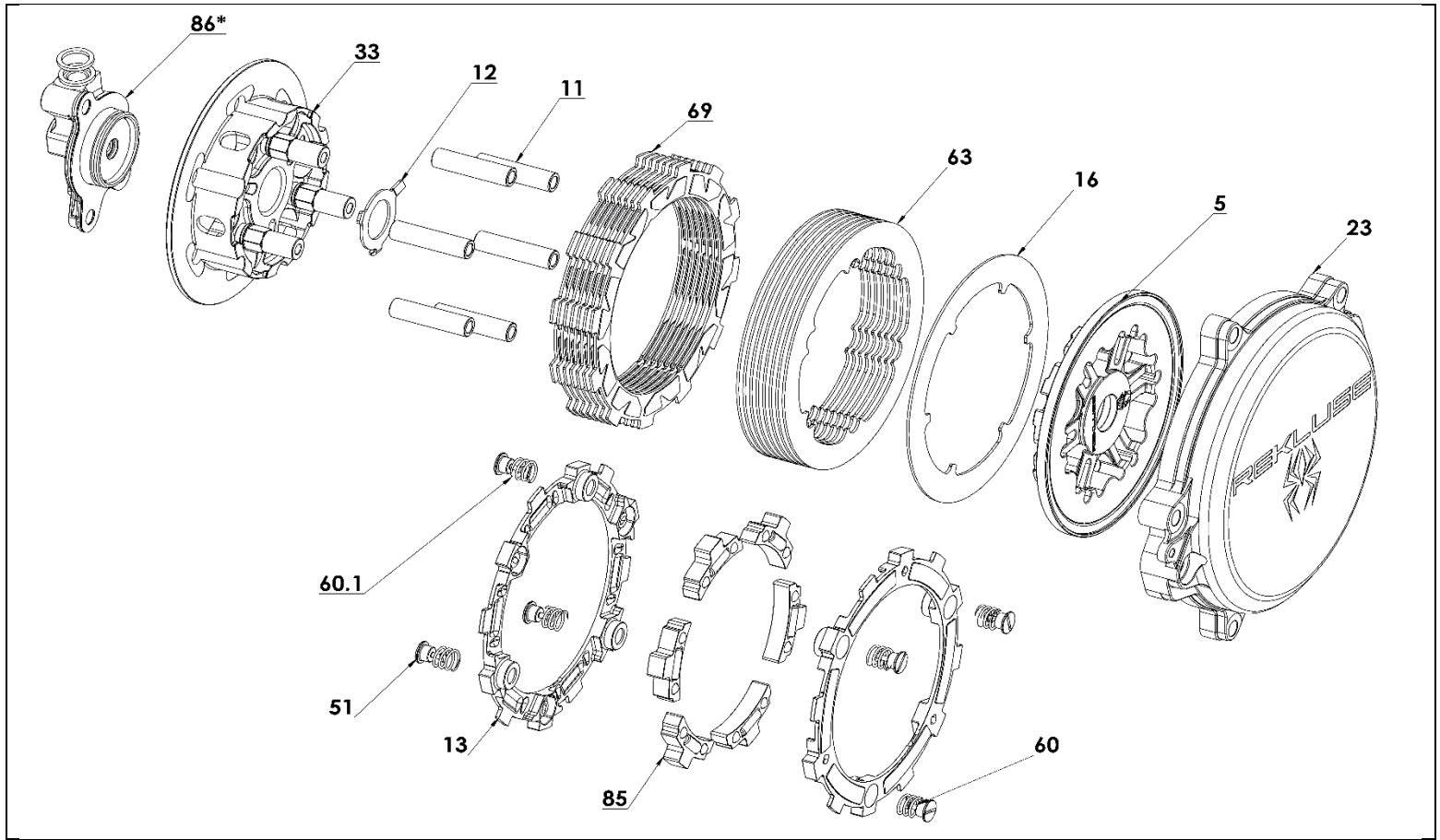

Item	Item Type	Qty
33	Center hub	1
69	TorqDrive® Friction Disks	7
63	Steel Drive Plate - .040" (1 mm)	8
16	Lining plate	1
5	Pressure plate	1
23	Clutch Cover	1
13	EXP bases	2
85	Wedge assembly	6
51	Quarter turn pin (includes 2 extra)	8
60	EXP adjustment springs (colors vary)	12
86	Adjustable slave cylinder	1
11	Drive Pin	6
12	Clutch tab lock washer	1
Not shown	Orange Free Play Gain rubber band	1

Visit [Rekluse.com/support](https://Rekluse.com/support) for a full parts fiche illustration and part numbers.

# **BIKE PREP & DISASSEMBLY**

1. Lay the bike on its left side. Catch any fuel that might drain in a suitable container.

2. Soak the EXP disk and TorqDrive® frictions in new engine oil for 5 minutes. Make sure the EXP and friction disks are coated on both sides.

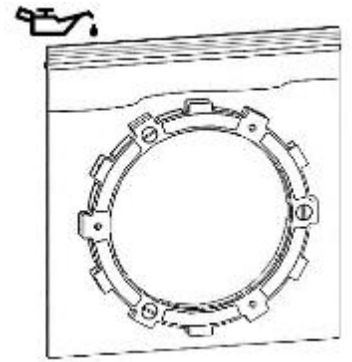

3. Using a socket, remove the clutch cover bolts, then remove the clutch cover.

4. Remove the OE parts named in the following diagram.

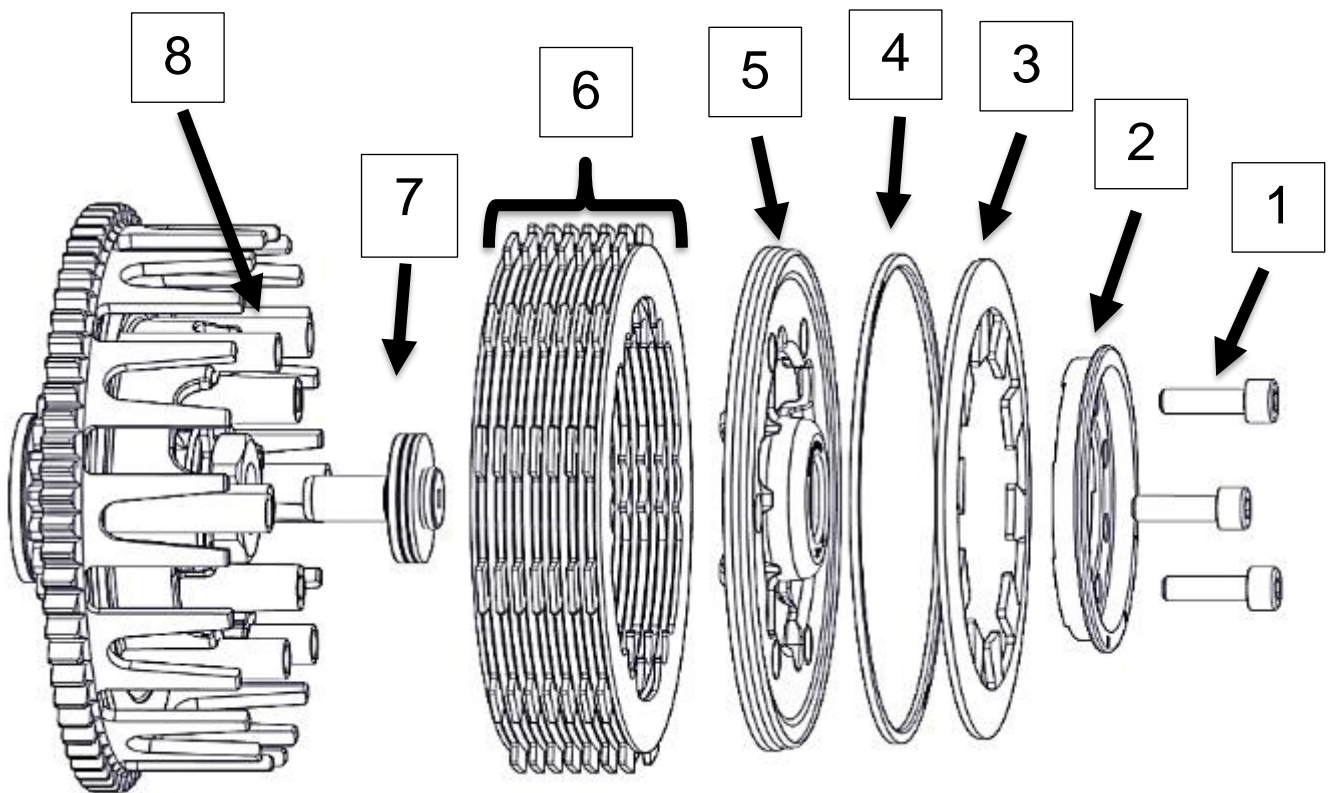

1	Pressure plate screws
2	Spring ring
3	Belleville spring
4	Slider ring
5	Pressure plate
6	Clutch pack
7	Throw-out
8	6 Drive pins

**NOTE:** Be careful that the drive pins do not fall into the engine while disassembling.

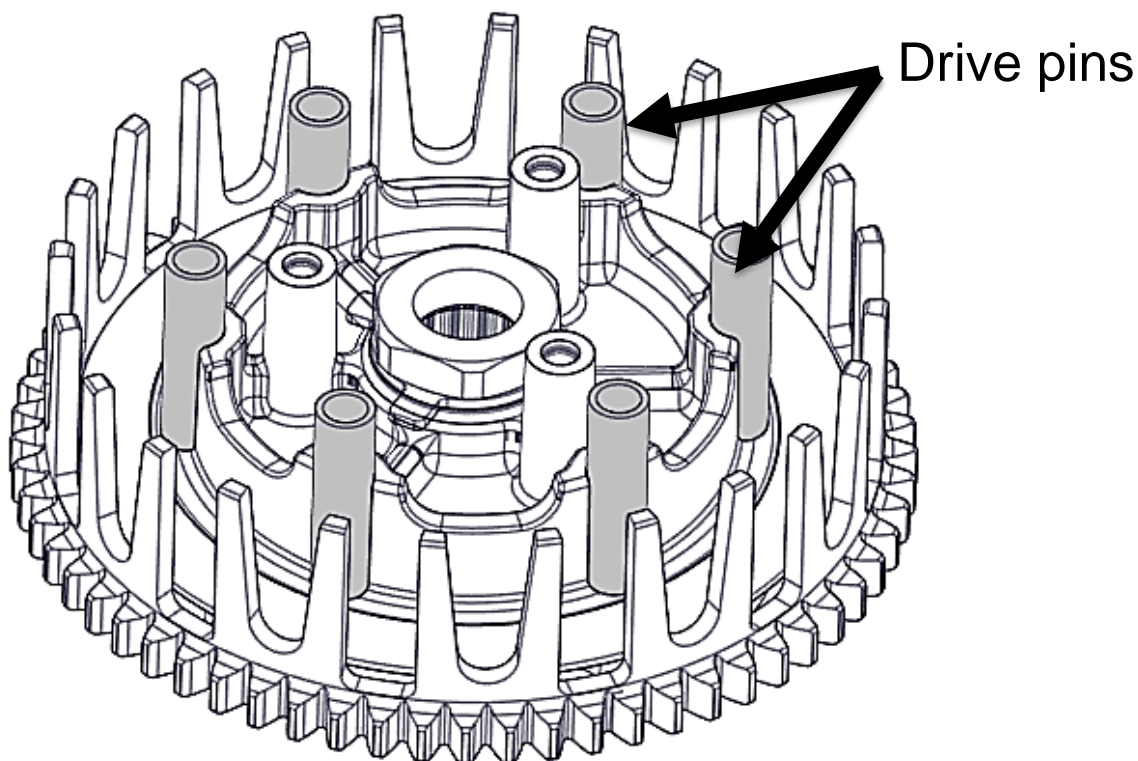

5. Use a hammer and large screw driver to bend down the tabs of the tab washer, then remove the clutch nut.

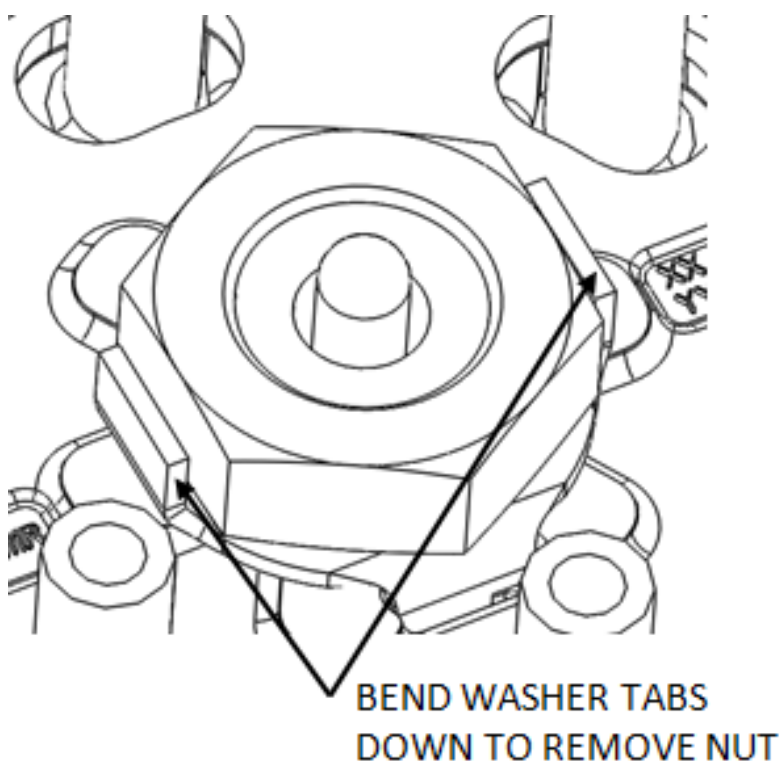

6. Remove the OE center hub assembly from the bike. *Make sure the thrust washer is in place on the main shaft and not stuck to the bottom of the center hub assembly.*

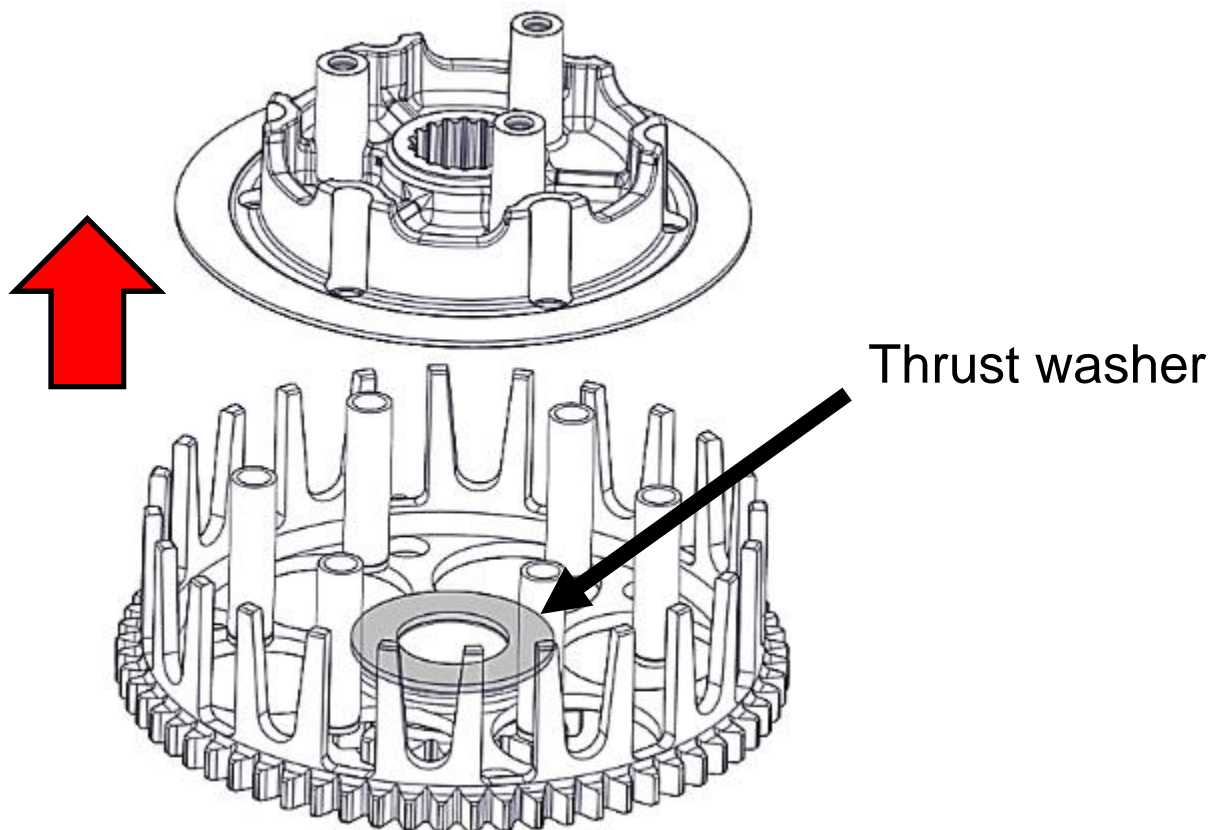

## **INSTALL THE CLUTCH PACK**

1. Install the new Rekluse center hub assembly into the clutch basket. *Make sure the thrust washer is on the main shaft before installing.*

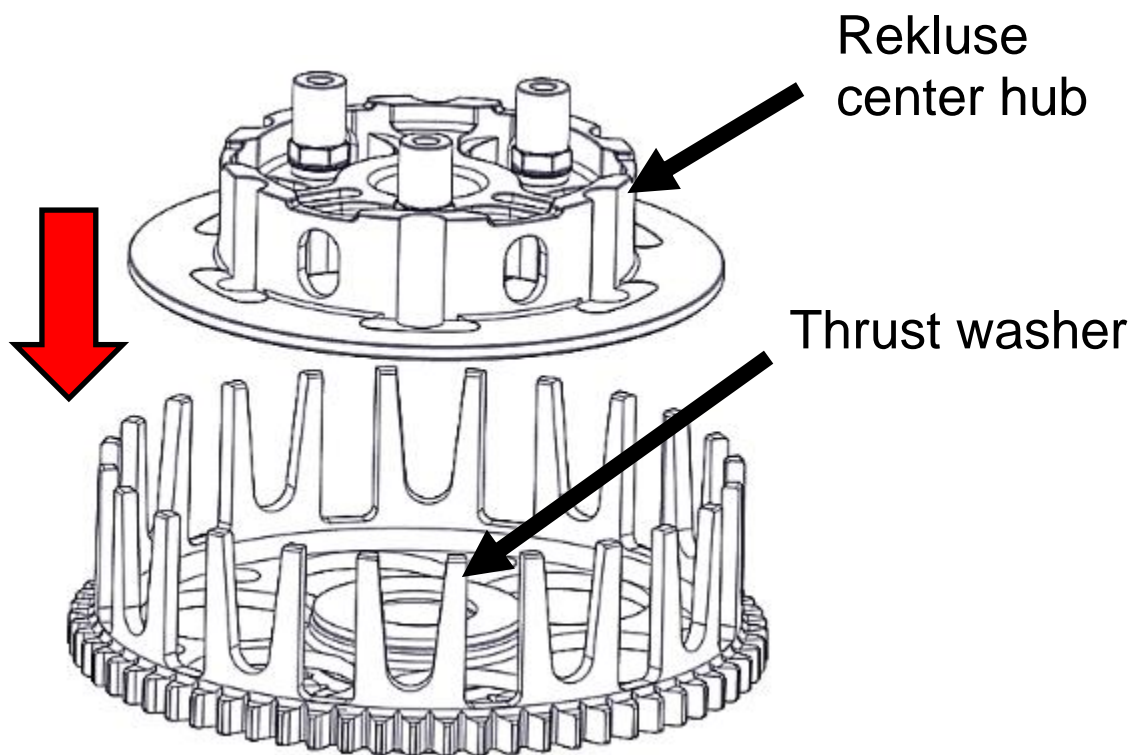

2. Install the new Rekluse tab lock washer and OE center clutch nut, then torque the nut to **50 ft-lb (68 N-m)**.

3. Use a screwdriver to begin bending both tabs of the lock washer up, then use channel-lock pliers to finish tightening it around the nut. *The tabs can be bent on the straight sides or around the corners.*

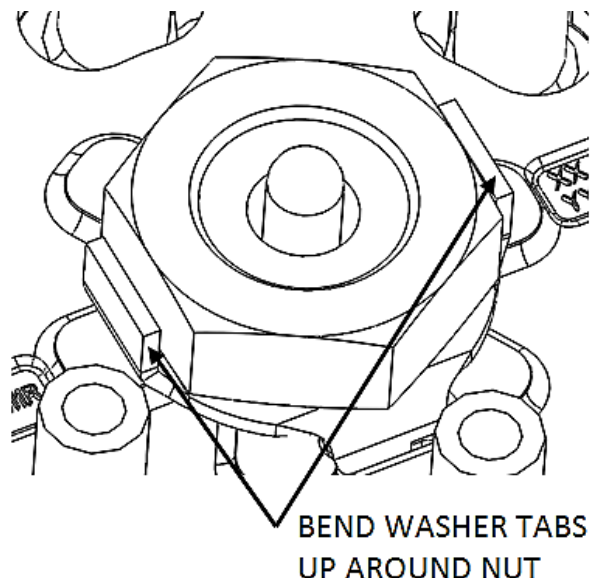

4. Seat the 6 Rekluse drive pins into the Rekluse hub.

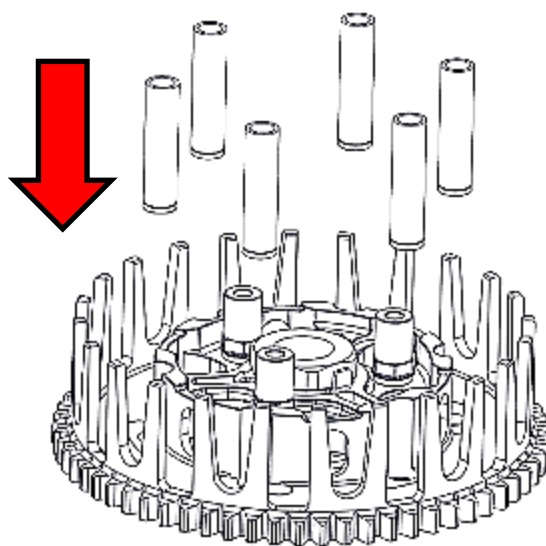

5. Install a Rekluse steel drive plate. Align the drive pin notches in the drive plate with the drive pins on the hub when you install it into the basket.

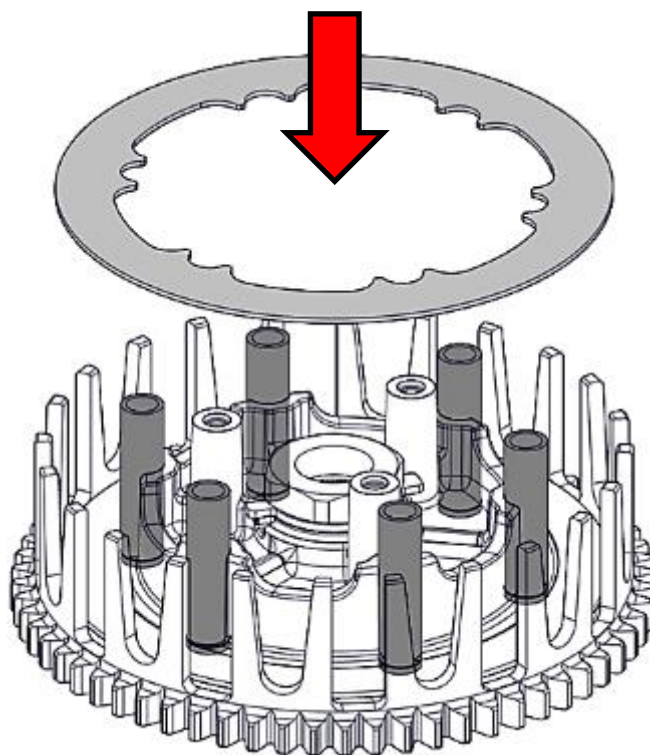



**NOTE:** Be sure that the drive pins are seated in the notches and not in the bigger sections. ALL the steel drive plates must be aligned in the drive pins notches or damage may occur. The plates will not move when installed correctly.

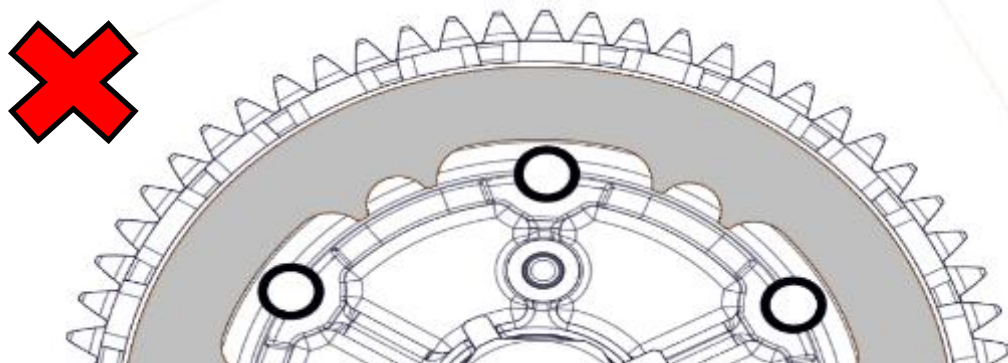
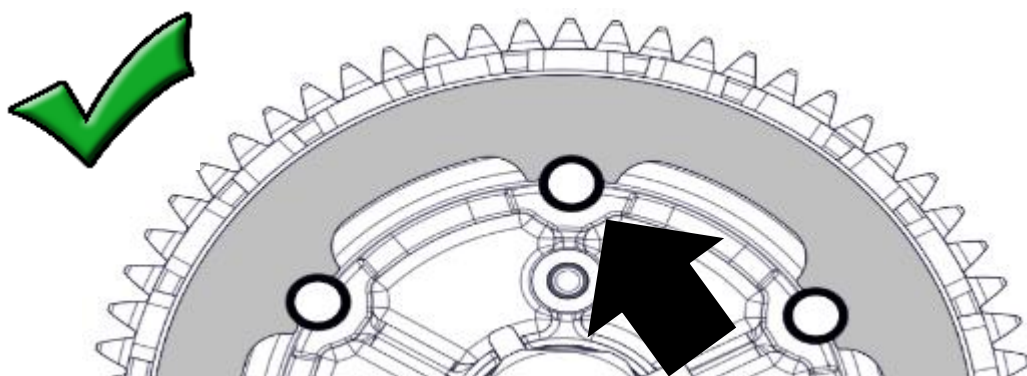

6. On top of the steel drive plate, install a Rekluse friction disk.

**NOTE:** The OE basket has tapered slots in alternating basket tangs. Rekluse products require the entire clutch pack be installed into the MAIN (deeper) basket slots. Installing the pack in the tapered slots will cause performance issues. See the following picture for reference.

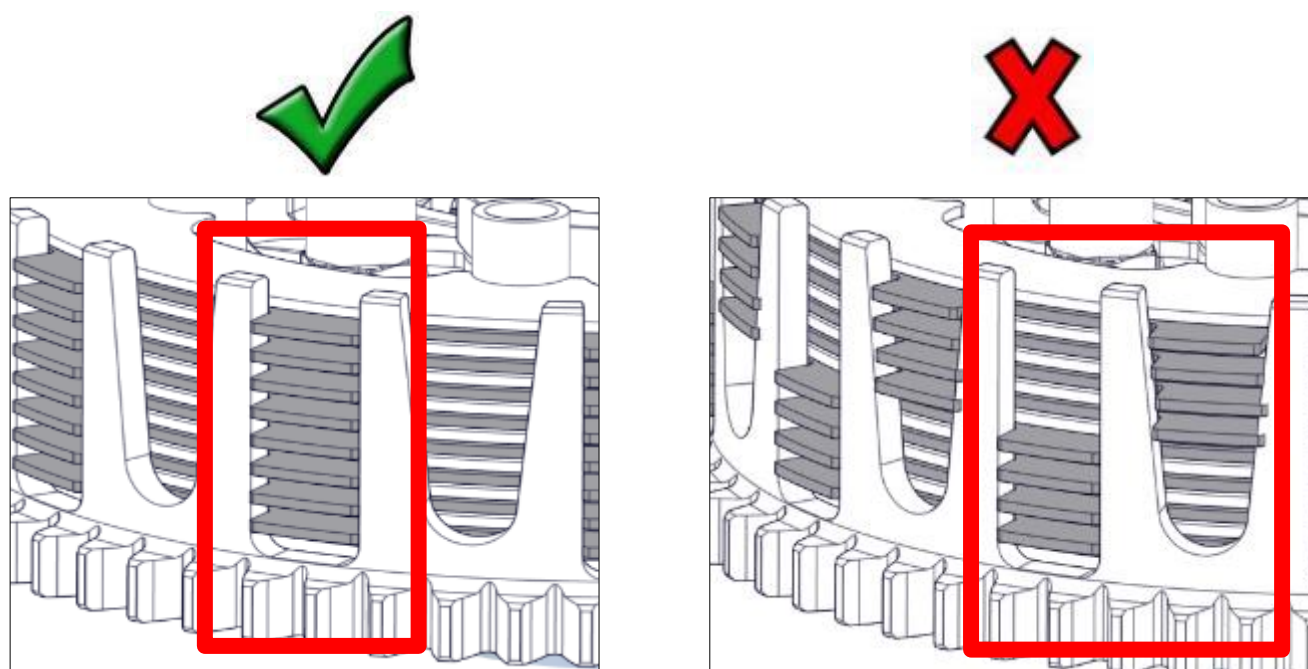

7. Continue to alternate steel drive plates and friction disks for the entire clutch pack for a **total of 8 steel drive plates and 7 friction disks**. *Some friction disks are marked with a small colored dot. This mark is used for processing and can be ignored.*

8. Install the EXP disk on top of the last steel drive plate.

9. Install the Rekluse lining plate on top of the EXP disk.

**Total clutch pack:**  
8 steel drive plates  
and 7 friction disks

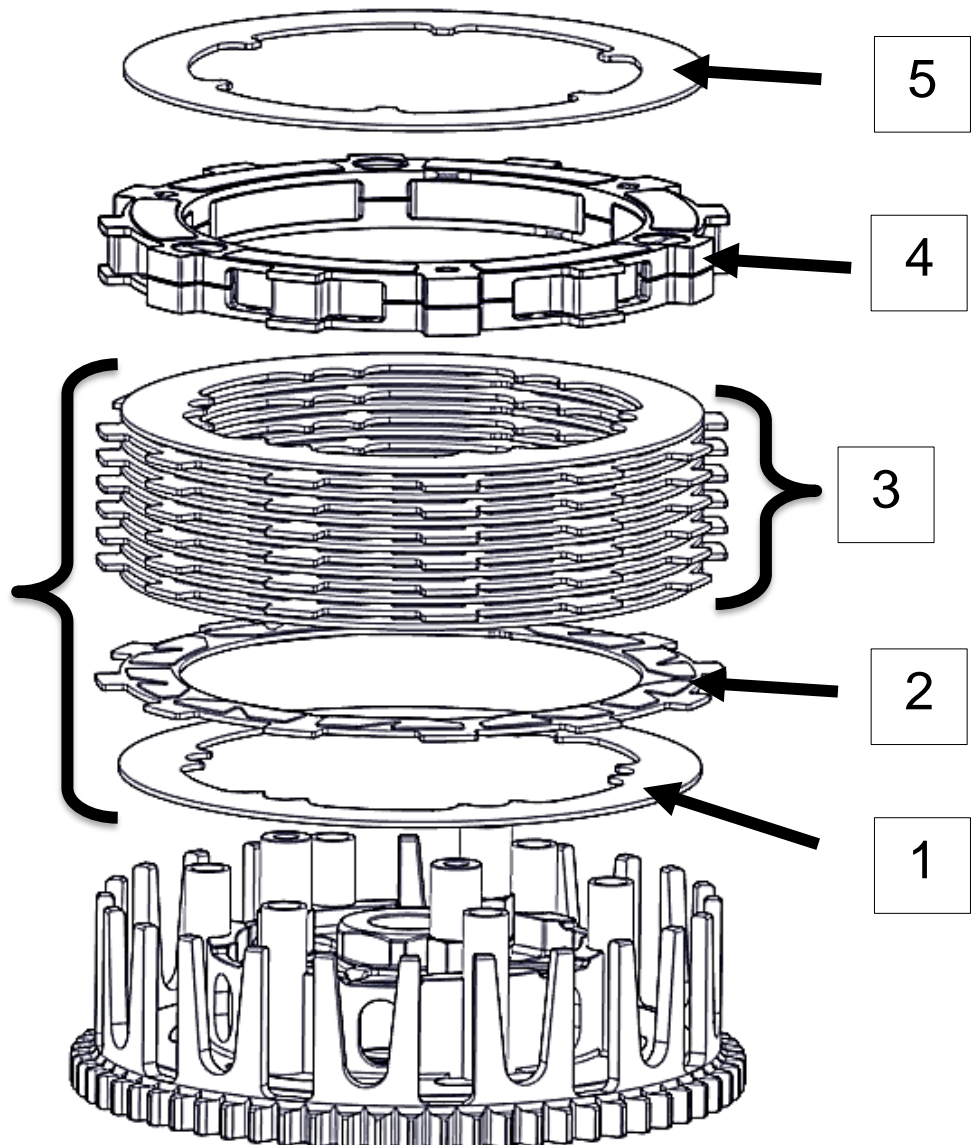

1	Steel drive plate
2	Friction disk
3	Alternate remaining steel drive plates with friction disks
4	EXP disk
5	Lining plate

10. Reinstall the OE throw-out.

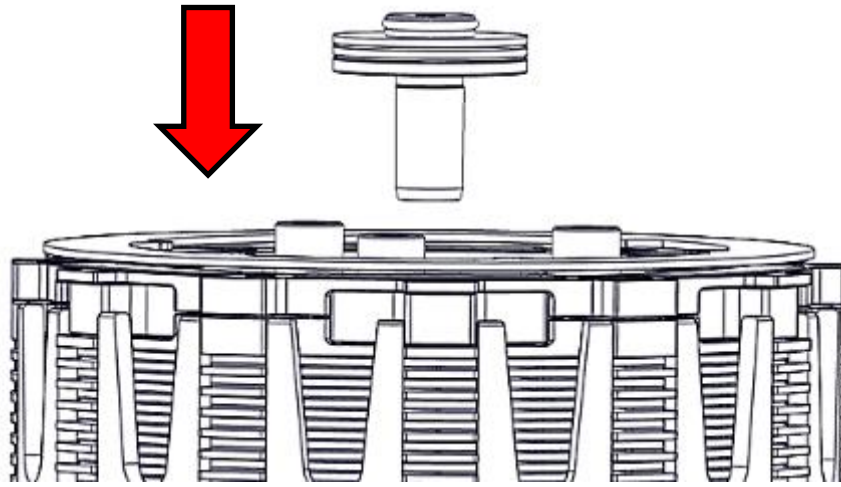

## **PRESSURE PLATE INSTALLATION**

1. Install the Rekluse pressure plate into the clutch pack.
2. Place the OE slider ring on the pressure plate with the “top” marking facing up. (The top side is rounded and the bottom edge is sharp.)

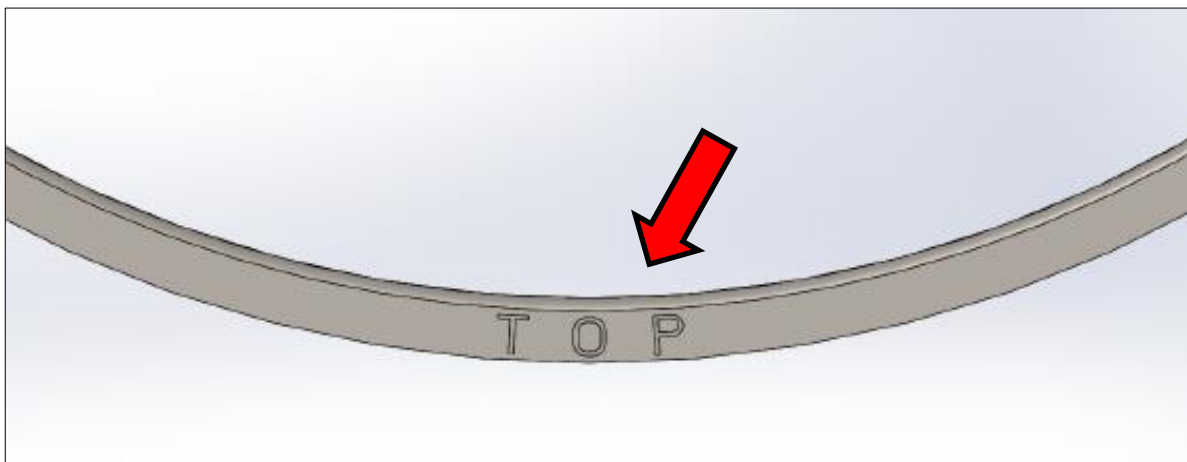

3. Install the OE Belleville spring onto the slider ring, with the rounded dome side facing up. See pictures for reference.

**NOTE:** *The outer edge of the Belleville spring will make contact with the slider ring. If it does not, the Belleville spring is upside down.*

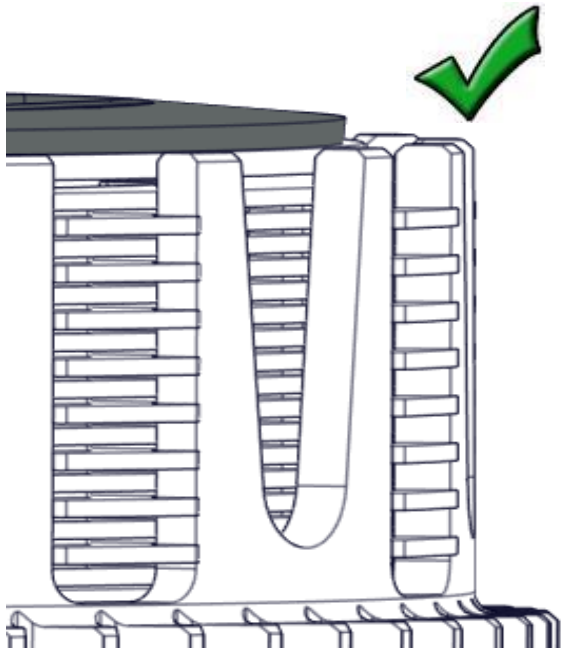

**Correct** – The Belleville spring sits flat against the slider ring.

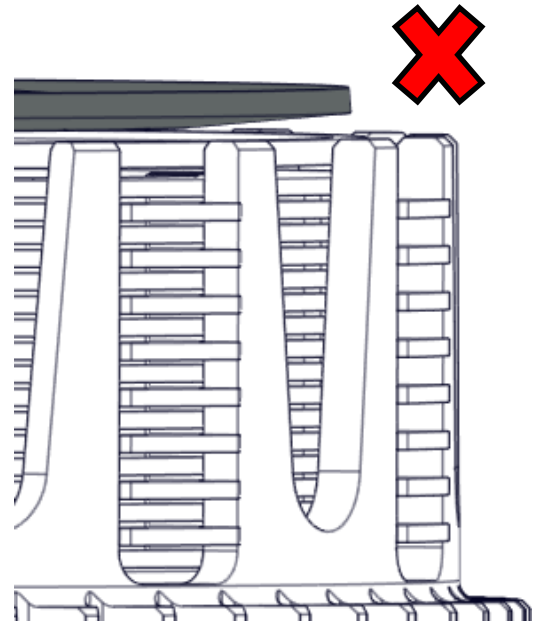

**Incorrect** – The Belleville spring is upside down.

4. Reinstall the OE spring ring.

**NOTE:** There are 3 possible settings on the OE spring ring. Rekluse recommends setting “2” for standard clamping force and performance. See the **Setup Sheet** located at the back of the manual for more information.

5. Reinstall the OE pressure plate screws.

6. Torque the pressure ring screws to **55 in-lb (4.5 ft-lb) (6 N-m)**.

7. Install the OE cover gasket onto the Rekluse clutch cover, then install the cover onto the clutch.

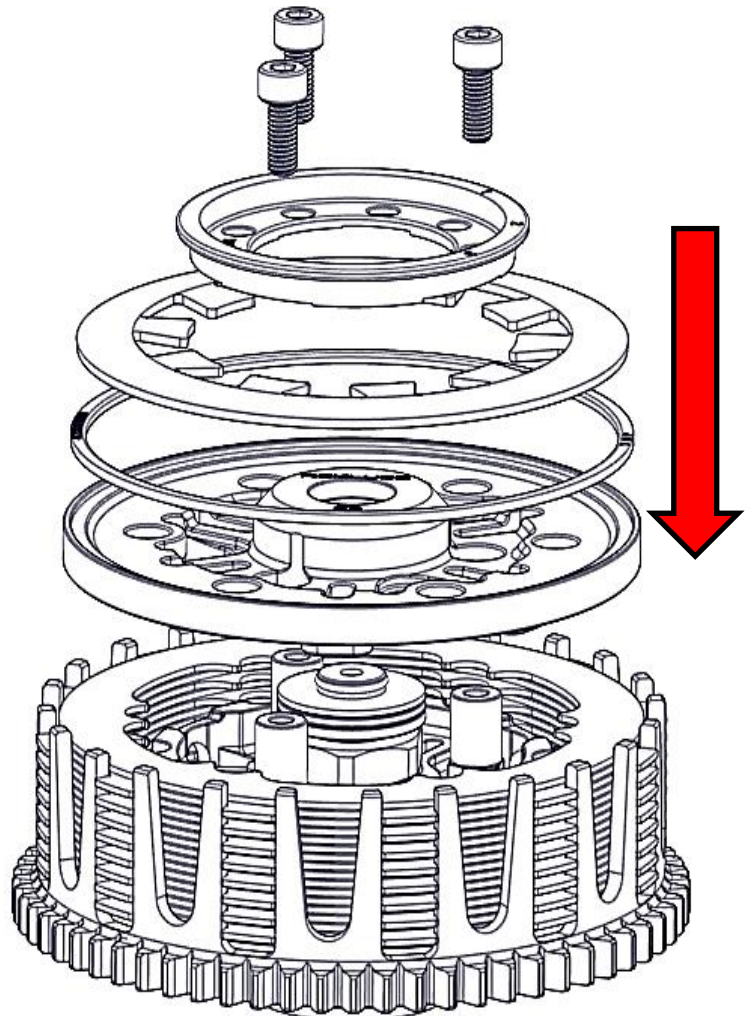

8. Reinstall the clutch cover bolts in their proper location, then lightly tighten the cover bolts in small increments in a star pattern. Torque the cover bolts to OE specifications.
9. Install the oil bolt washer and bolt from the OE cover to the Rekluse cover, then tighten the bolt until snug.

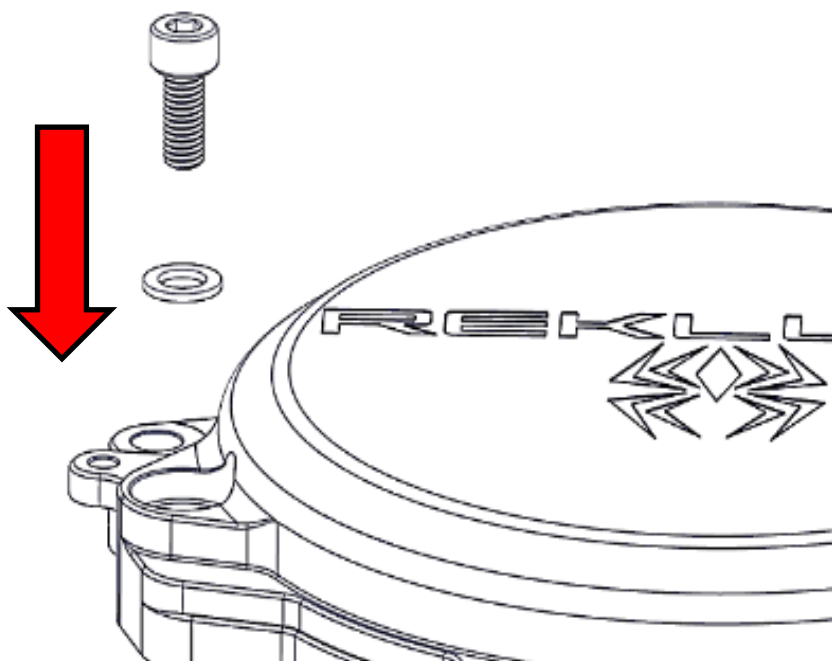

## **SLAVE CYLINDER INSTALLATION**

Installing the new Rekluse slave cylinder takes several steps. Please read the entire section before beginning the process to ensure you have the right equipment and clutch fluid needed for the replacement. Rekluse recommends wearing gloves and safety glasses for the install.

### **⚠ CAUTION**

*During the bleed and assembly, note that there is a small ball bearing installed in the slave piston with a small amount of grease. When installing the Rekluse slave cylinder, make sure the ball is in place and has not come loose.*

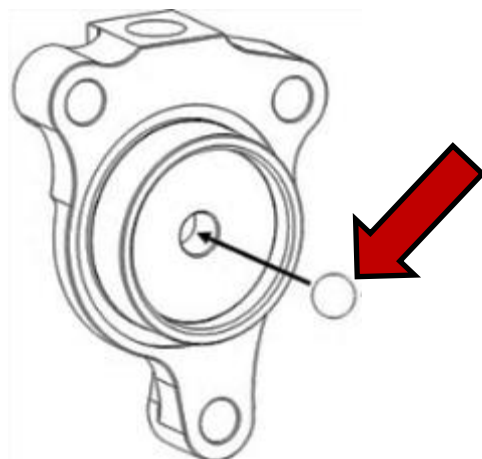

## Step 1: Bleed the new slave cylinder

This step prepares the new slave cylinder for installation. Bleed the cylinder on a workbench or an area away from the bike.

1. Using a 4 mm hex key, turn the adjuster screw counterclockwise so that the top O-ring is visible under the adjuster screw.

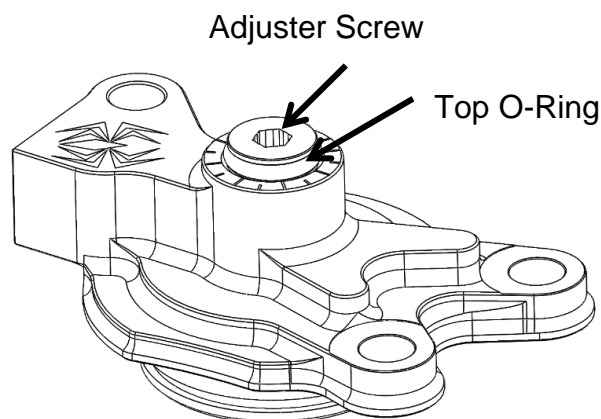

2. Use your thumbs to compress the piston until it bottoms out, then release it.

### **CAUTION**

***When compressing the piston, fluid can shoot out from the slave cylinder port. Be sure to wear eye protection.***

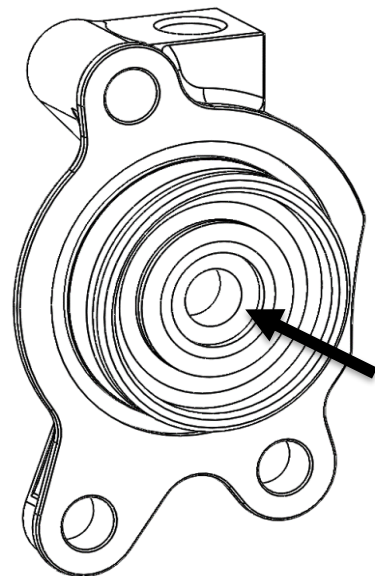

3. Pour the manufacturer recommended clutch fluid into the slave cylinder port. *Wipe any fluid that spills off of the piston to prevent seal contamination.*

### **CAUTION**

***Be sure to use the correct clutch fluid. Check the cap of the clutch master cylinder to determine which clutch fluid to use. Failure to use the correct fluid will result in seal damage and/or failure.***

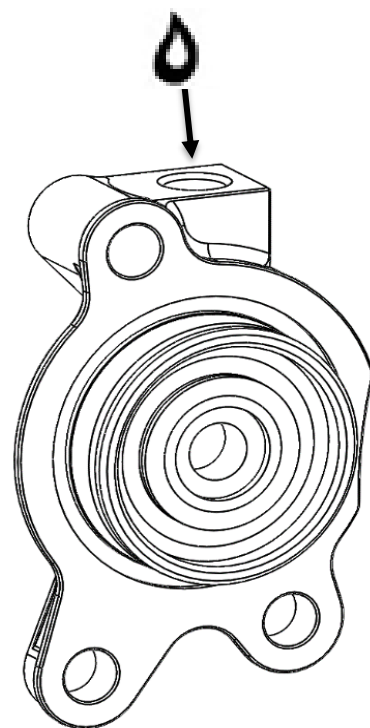

4. Use the hex key to turn the adjuster screw **clockwise** until it bottoms out and the O-ring is no longer visible. Keep the fluid topped off as you go.

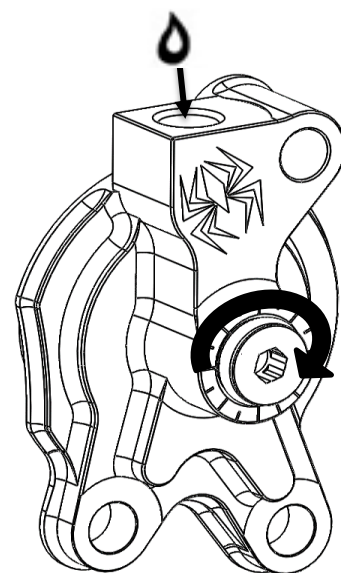

5. Use the hex key to turn the adjuster screw **counterclockwise** back to the initial position, with the top O-ring visible. Keep the fluid topped off as you go.

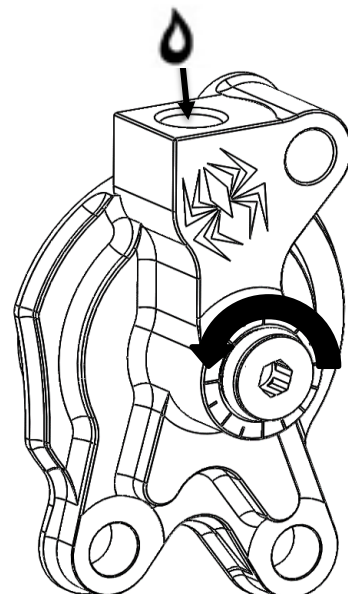

6. Use your thumbs to compress the piston again until it bottoms out while looking for air bubbles.

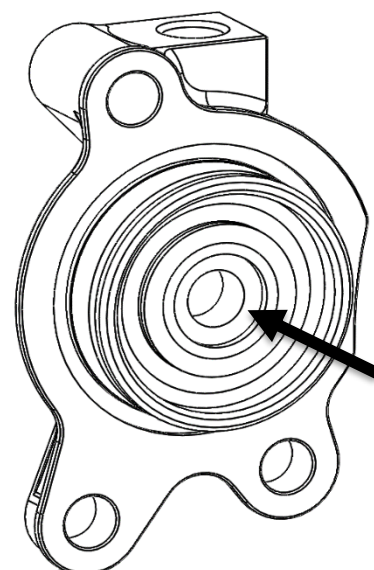

7. Repeat steps 3 - 6 until there are no air bubbles coming out in the fluid when the piston is compressed.

8. When the bleeding is complete, turn the adjuster screw **counterclockwise** so that the top O-ring is visible.

9. Compress the piston until it bottoms out and top off with fluid.
10. Check that the ball bearing is still in place. Stand the Rekluse slave cylinder in an upright position (so the fluid does not spill) until it is needed in the next step.

**Note:** Some models have a piston diaphragm seal. **DO NOT** reuse them if OE equipped. The Rekluse slave cylinder does not require a diaphragm seal.

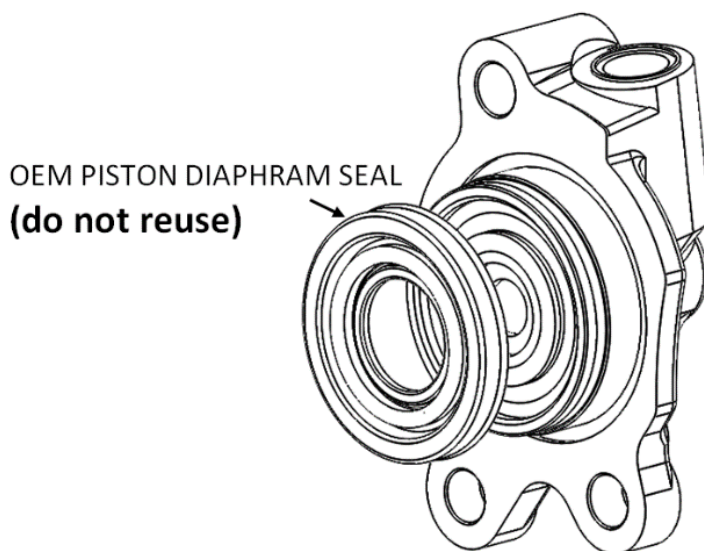

## Step 2: Replace OE slave cylinder

In this step, the OE slave cylinder is replaced with the Rekluse slave cylinder. Work quickly when performing the following steps. This method retains the fluid inside the line, and makes the final bleeding step easier.

1. Stand the bike up and lean it on its kickstand, or place it on a suitable bike stand.





2. On the left side of the bike, while leaving the OE slave cylinder intact on the engine, use a wrench to remove the banjo bleeder bolt from the OE slave cylinder.
3. Remove the clutch fluid line and the 2 OE crush washers from the OE slave cylinder. Discard the OE crush washers.

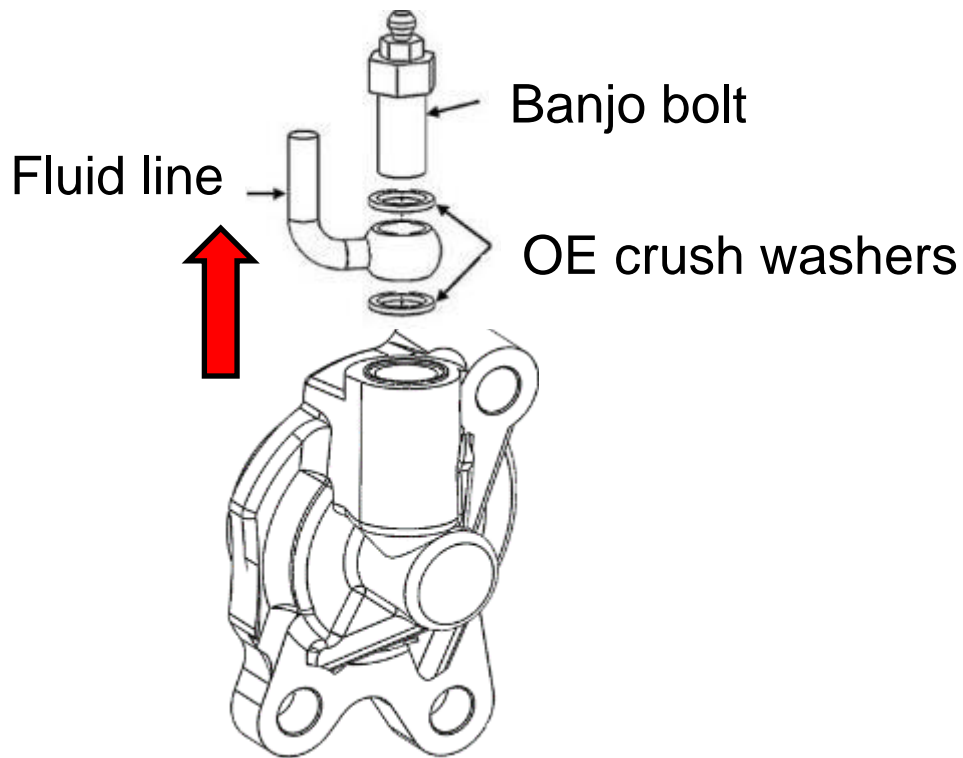

4. Attach the clutch fluid line to the Rekluse slave cylinder using the OE banjo bleeder bolt and the 2 new crush washers from Rekluse. Make sure the clutch fluid line is between the 2 crush washers.

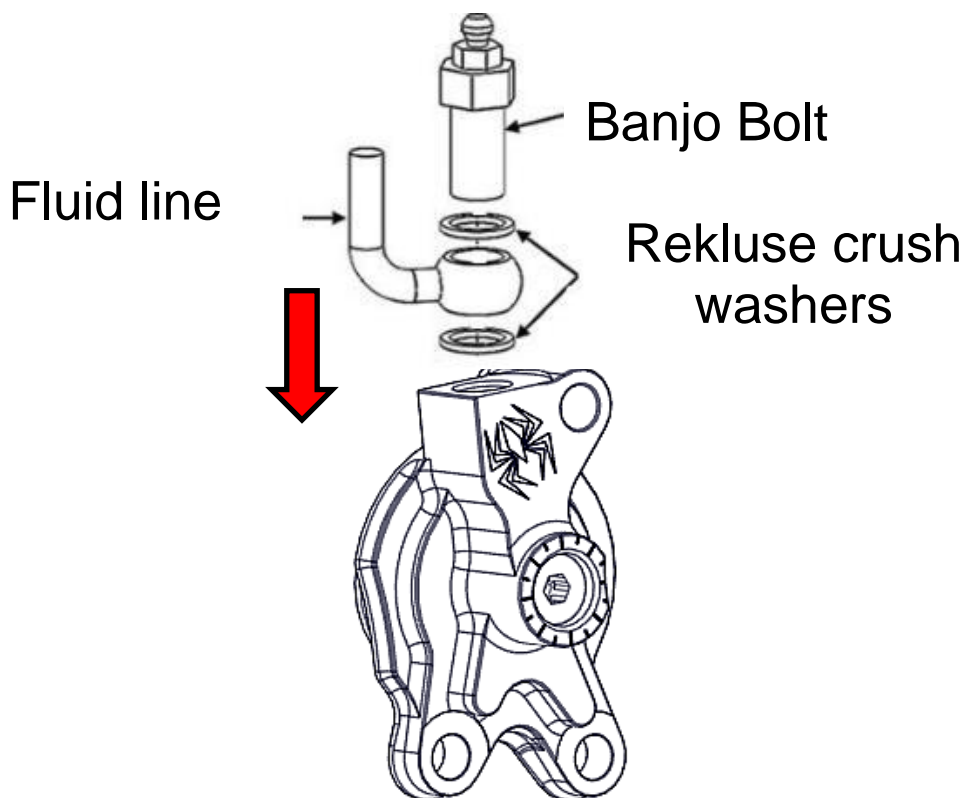

5. Tighten the banjo bolt with your hand until snug. (You will torque it to spec once installed on the bike.)
6. With the clutch fluid line attached to the Rekluse slave cylinder, remove the OE slave cylinder from the engine. Keep the OE bolts for reuse.

OE Bolts  
(Reuse)

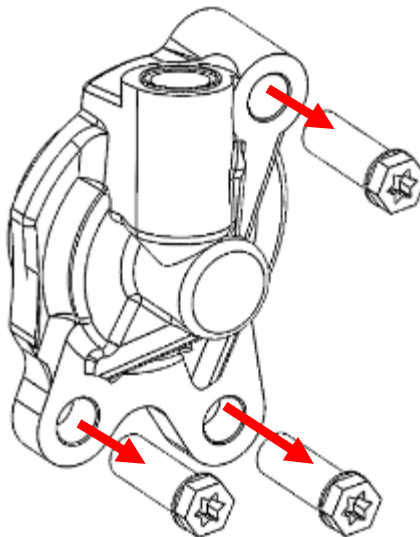

7. Mount the Rekluse slave cylinder to the engine using the OE bolts.
8. Torque the banjo bolt to OE specification.

## **BLEED THE CLUTCH LINE**

1. Attach one end of the supplied bleed tube to the banjo bolt port, then loop the opposite end into a suitable catch bottle.

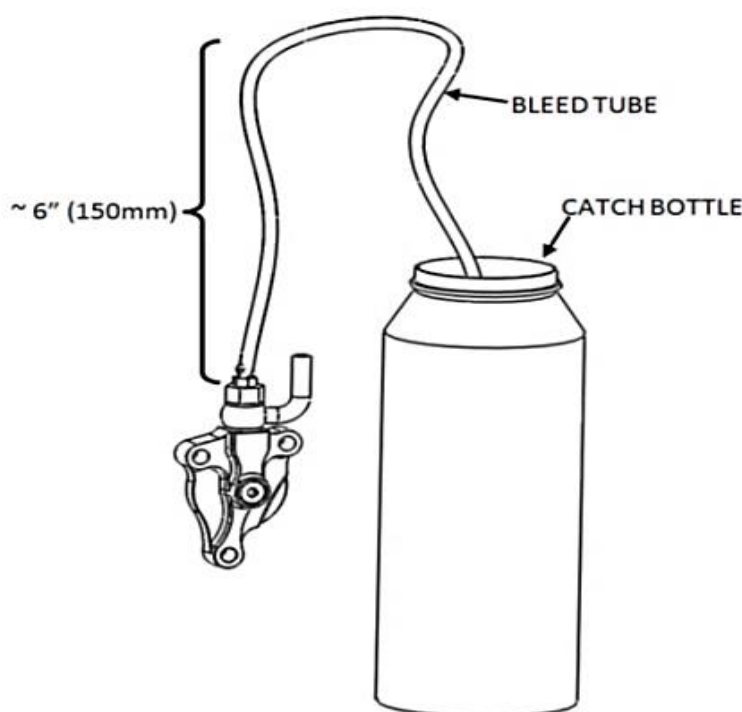

2. On the handlebar, remove the cap and bladder from the clutch master cylinder. Adjust the reservoir so it is level with the ground.

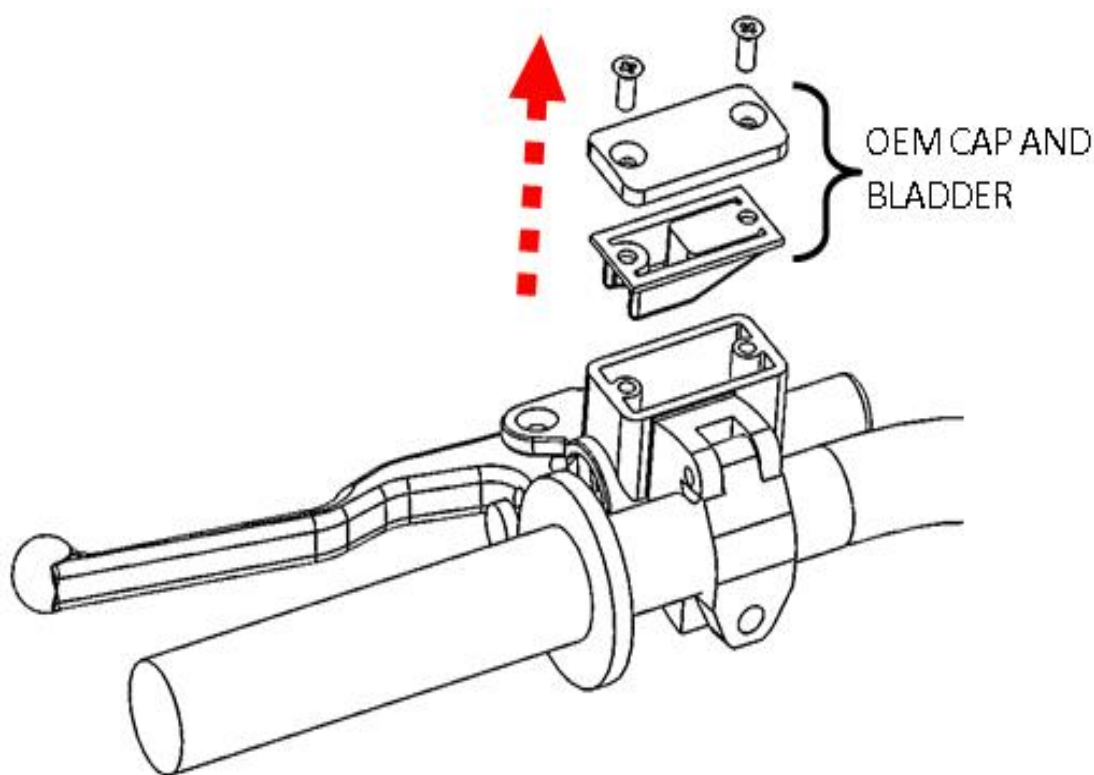

3. Top off the master cylinder with the recommended clutch fluid until it is 75% full.

4. Pump the clutch lever 3 to 5 times, then hold it against the handlebar/grip.

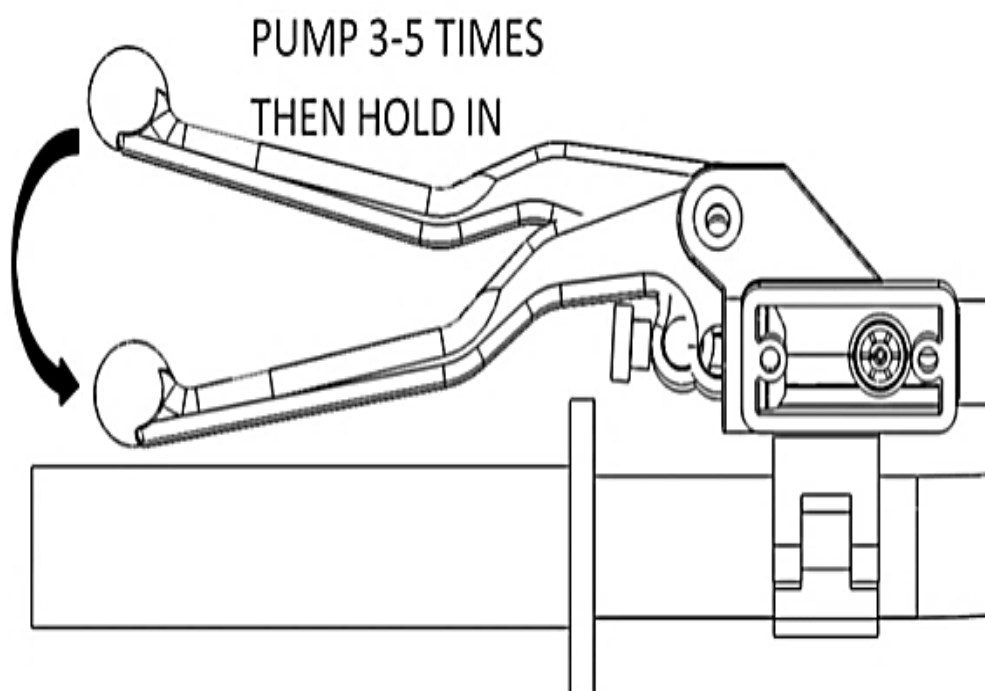

5. While still holding the clutch lever in, use a wrench to open the bleed port. Air and fluid should flow from the bleed tube.

6. Before releasing the clutch lever, tighten the bleed port when the pressure is released from the bleed tube.
7. Slowly release the clutch lever and check the fluid level in the clutch master cylinder. Top off if necessary.

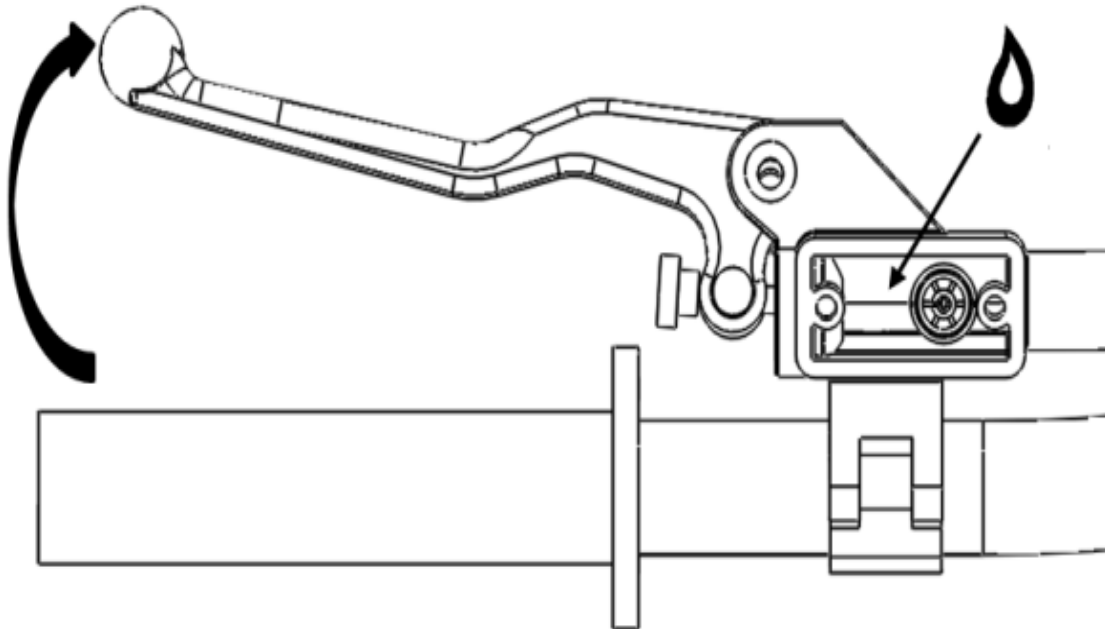

8. Repeat steps 4 - 7 until air no longer comes out of the bleed tube and the clutch feels normal.
9. Check that the clutch master cylinder is 75% full, then replace the cap and bladder.

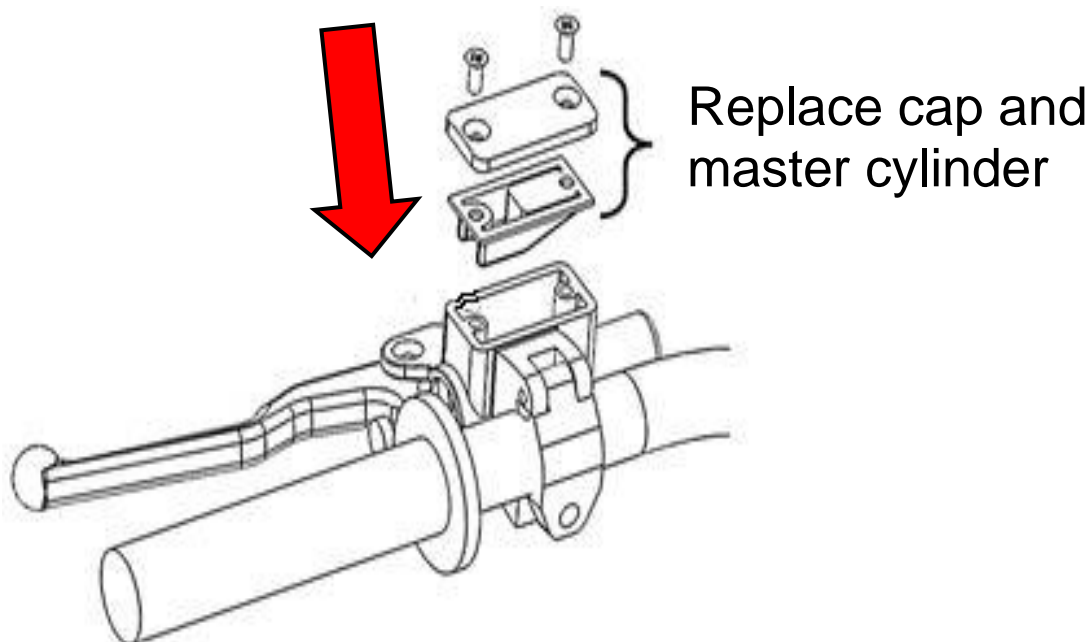

10. Remove the bleed tube from the bleed bolt and remove the bottle.
11. Torque the bleed screw to **150 in-lb (17 N-m)** with a socket or the closed end of an 8 mm wrench.

**Note:** Be sure to use a socket or closed end wrench when torqueing the bleed screw. Using an open-ended wrench can strip the hex screw.

12. Finally, install the rubber dust cap over the bleeder screw.

## **CHECK FREE PLAY GAIN**

It is very important that you understand how to verify the correct installed gap by checking Free Play Gain. The installed gap is what allows the auto function of the product to perform properly.

### **Correct Free Play Gain = Correct installed gap**

Setup, break-in, and rechecking the installed gap is CRUCIAL. Failure to properly maintain your installed gap can result in premature wear or failure of your clutch. Use the following steps to verify the installed gap by checking Free Play Gain.

#### **▲ WARNING**

**Failure to check and verify Free Play Gain can cause failure or damage to this product. Setting the correct installed gap is critical for clutch performance.**

Setting the installed gap and checking Free Play Gain is a 4-step process. It is important to follow each step to ensure that your new clutch functions as designed.

## **Step 1: Find the starting point**

- a) With the bike standing up, locate the adjuster screw in the center of the adjustable slave cylinder.
- b) With the O-ring showing, use a 4 mm hex key to turn the adjuster screw **clockwise** until it stops under light pressure. This is your “starting point.”

**Note:** The resistance you feel is where the throw-out begins to lift the pressure plate. Finding the right starting point may take a few tries, but you will feel a noticeable change in turning effort once you reach that point. Stop when you feel the pressure increase. The “starting point” will change as the clutch pack wears over time.



- c) Once you have found the starting point, note the position of the hex key using the tick marks on the slave cylinder housing and the small etch mark located on the screw. You will begin here to adjust the installed gap.

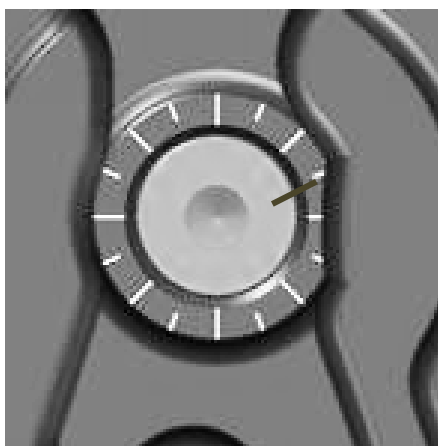

Use the tick marks on the cylinder and the etch mark on the screw for adjusting the gap.

- d) Use the hex key to turn the adjuster screw clockwise **1 full turn + 2 tick marks** from your starting point. This may NOT be your final setting, but it is a beginning adjustment for finding the correct setting.

**⚠ CAUTION**

***Do not ride your bike without the adjusting the installed gap. You will not be able to disengage the clutch until you set the installed gap.***

- e) Continue with Step 2 to check for Free Play Gain.

## Step 2: Learn how to check Free Play Gain

If you are familiar with checking Free Play Gain, check for Free Play Gain then skip to the “Adjust the Installed Gap” section.

If Free Play Gain is new to you, follow the instructions below to help you learn this important step. You can also view the video entitled “How to Check Free Play Gain” on our website at <https://rekluse.com/support/videos>.

Checking Free Play Gain allows you to externally monitor the installed gap so you can know when to make an adjustment if the installed gap is too large or too small.

The correct installed gap is verified by observing and feeling the increased free play movement in the clutch lever. This extra movement is called “Free Play Gain.”



Lever with “slack” removed

Lever position around 5,000 RPM

**Free Play Gain**  
1/8”-1/4” (3 mm-6 mm) lever movement

**Optimal Free Play Gain yields 1/8" to 1/4" (3 mm-6 mm)** of clutch lever movement, measured at the ball end of the lever. This measurement at the lever correlates to achieving the ideal installed gap.

## **Two Ways to Check for Free Play Gain**

The following steps explain **2 ways** to check Free Play Gain. One way uses the rubber band Rekluse includes in the clutch kit, and one uses your hand. You can use either method to check for Free Play Gain.

Rekluse recommends that you begin with the rubber band method first to check for Free Play Gain and then learn the hand method. The rubber band will help you learn how to recognize Free Play Gain until you are comfortable with the hand method. Learning to check Free Play Gain by hand effectively and comfortably can make it easy to check Free Play Gain every time you ride.

## **The Rubber Band Method**

Use the rubber band method for the initial set up. It can also be used before each ride until you feel comfortable checking the Free Play Gain using the hand method.

### **▲ WARNING**

**BEFORE YOU BEGIN, verify that the bike is in NEUTRAL before checking Free Play Gain. Failure to do so may result in the bike lurching forward, and loss of control and/or injury may result.**

**A Rekluse auto-clutch can make your motorcycle appear to be in neutral when in gear, even when the engine is running and clutch lever released.**

**Motorcycles equipped with a Rekluse auto-clutch can move suddenly and unexpectedly and cause riders to lose control. To avoid death, serious injury, and/or property damage, always sit on the motorcycle to start it.**



a) Before you begin, place the bike in **NEUTRAL**, start the engine and let it warm up for 2-3 minutes to idle down and warm the engine oil.

b) Stretch the included rubber band between your thumbs, then place the top end of the rubber band on the outer end of the left handlebar grip.



c) While holding the top end of the rubber band against the handlebar, stretch the band downward, then loop it through itself.



d) Pull the band through the loop, then attach it to the outside end of the clutch lever. This will take up the initial free play (slack) and put the lever in a position to detect the Free Play Gain.



e) While still in **NEUTRAL**, quickly rev the engine between 5,000-7,000 RPM ( $1/2$  to  $3/4$  throttle), then let it return to idle. Notice the movement in the clutch lever when the engine is revved. This is your Free Play Gain.

**Note:** *It is very important the motor returns to idle before revving the engine again or Free Play Gain will not be correct.*

- f) When the bike returns to idle, rest your hand across the clutch lever. Rev the engine again to 5,000-7,000 RPM so you can observe the movement while feeling for Free Play Gain with your hand.

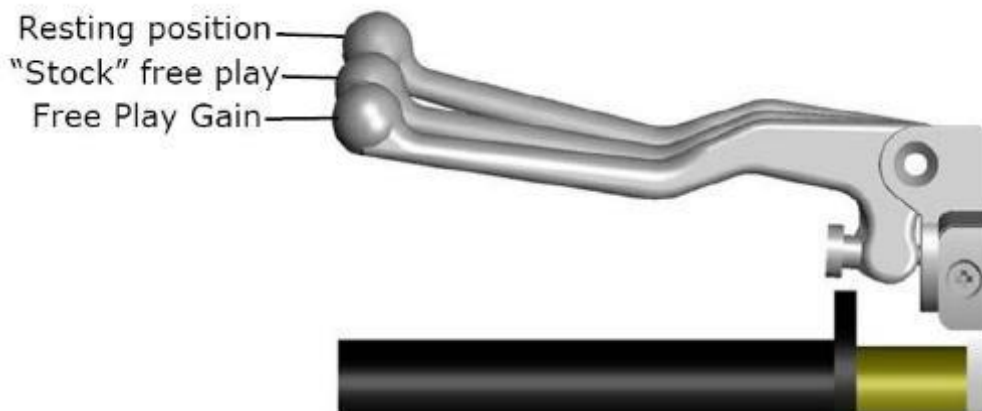

## **The Hand Method**

Use the hand method to check Free Play Gain before the start of every ride for optimum performance and longevity of your new clutch.

- a) Before you begin, place the bike in **NEUTRAL**, start the engine and let it warm up for 2-3 minutes to idle down and warm up the engine oil.
- b) With the bike at idle, apply enough pressure to the clutch lever to take up the initial free play (slack) in the clutch lever.
- c) While still in **NEUTRAL**, continue to apply light pressure and quickly rev the engine between 5,000-7,000 RPM (1/2 to 3/4 throttle), then let it return to idle. Notice the movement in the clutch lever when the engine is revved. This is your Free Play Gain.
- d) When the bike returns to idle, rev the engine between 5,000-7,000 RPM a second time to feel the Free Play Gain again.
- e) Continue with Step 3 to break-in the new clutch.

## Step 3: Break-in the new clutch

Once you install your new clutch, it is important to break it in. A series of roll-on starts are used to break in the clutch. Follow these procedures for breaking in your clutch and any time new friction disks, EXP bases, Teflon pads, or wedges are installed.

### ⚠ WARNING

**Failure to follow the break-in procedure and oil screen inspection process could cause motor oil delivery failure, which can result in motor failure, serious injury, or death.**

Break-in Procedure	Number of times
<p><b>Rev Cycles:</b></p> <ol style="list-style-type: none"> <li>Place the bike in <b>NEUTRAL</b>.</li> <li>With your hand <b>off</b> the clutch lever, rev the engine 10 times, being sure to let it <b>return to idle</b> between each rev cycle.</li> </ol>	<p>① <b>N</b> ② ③ ④ ⑤</p> <p>10 rev cycles</p>
<ol style="list-style-type: none"> <li>With the engine still running, pull in the clutch lever, then click the bike into 1<sup>st</sup> gear. Slowly release the clutch lever. The bike should stay in place or have a slight amount of forward creep.</li> <li>With the bike idling in first gear, slowly apply throttle to begin moving.</li> <li>Without using the clutch lever, accelerate moderately to approximately 5,000 RPM to fully engage the clutch and come to a complete stop. Repeat 10 times.</li> </ol>	<p>① <b>N</b> ② ③ ④ ⑤</p> <p>10 roll-on starts</p>

**Note:** *If the engine wants to stall or the creep is excessive, the idle may be too high or the installed gap may be too small. Make necessary adjustments before proceeding.*

6. Without using the clutch lever, start in 2<sup>nd</sup> gear, then accelerate moderately to approximately 5,000 RPM and come to a complete stop. Repeat 10 times.



10 roll-on starts

7. Place the bike in **NEUTRAL** and recheck Free Play Gain.

8. Continue to step 4 to adjust the installed gap until the Free Play Gain of the clutch lever is 1/8" to 1/4" (3 mm-6 mm).



Recheck Free Play Gain and adjust the installed gap

**Note:** *Your clutch pack will expand with heat, so final adjustment to Free Play Gain should be made when the bike is warm. Remember not to ride without sufficient Free Play Gain.*

**CAUTION**

**Do not perform 3<sup>rd</sup> gear starts with this product. Starting in 3<sup>rd</sup> gear will burn up the clutch and decrease the performance of this product in a short amount of time.**

## Step 4: Adjust the installed gap

Once you have learned how to check Free Play Gain, you need to finish adjusting the installed gap, then recheck the Free Play Gain until the clutch lever moves only 1/8" to 1/4" (3 mm-6 mm). The gap is adjusted by turning the slave cylinder screw.

- a) With the bike running and in **NEUTRAL**, locate the adjuster screw in the center of the adjustable slave cylinder.
- b) Use a 4 mm Allen wrench to turn the adjuster screw clockwise 1 tick mark from the last setting, then recheck Free Play Gain.



Tick marks are located on the slave cylinder, and an etch mark is on the screw. If you need to re-position the Allen wrench, you can use these marks for reference.

- c) Continue to adjust the slave cylinder 1 tick mark at a time until optimal Free Play Gain is achieved.
- d) Refer to the following pictures and chart in the next section for additional adjustment information.
- e) The Free Play Gain will change as the clutch pack wears over time.
- f) Checking the Free Play Gain is easy and indicates when the install gap needs adjusting.

# FREE PLAY GAIN ADJUSTMENTS

Make each adjustment in small increments - one tick mark at a time. After each adjustment, recheck Free Play Gain until you achieve the optimal 1/8" to 1/4" (3 mm-6 mm) of clutch lever movement.



Symptom	Reason	Solution
<ul style="list-style-type: none"> <li>• Clutch lever moves in too far (too much Free Play Gain)</li> <li>• Clutch has excessive drag or stalls</li> <li>• It is difficult to fully override the clutch with the lever</li> </ul>	<p>Installed gap is too small</p>	<p>Turn the adjuster screw <b>clockwise</b> 1-2 marks to increase the installed gap.</p> <p>Recheck Free Play Gain.</p>
<ul style="list-style-type: none"> <li>• Clutch lever only moves slightly or does not move at all (too little Free Play Gain)</li> <li>• Clutch slips</li> <li>• Bike seems to lose power</li> </ul>	<p>Installed gap is too large</p>	<p>Turn the adjuster screw <b>counterclockwise</b> 1-2 marks to reduce the installed gap.</p> <p>Recheck Free Play Gain.</p>

# EXP TUNING OPTIONS

Adjusting the engine idle speed to match your engagement setting is important and greatly affects the overall feel of how the EXP disk engages.

To prevent freewheeling and maximize engine braking, set the idle so there is a slight amount of drag while the bike is idling in gear and warmed up. The idle should not be so high as to move the bike forward in gear with the throttle closed. However, with a small opening of the throttle the bike should move forward.

You can tune the engagement RPM of the EXP disk by changing the spring configuration. The EXP disk comes set with the recommended “**Medium**” setting from Rekluse. Use the following steps to change the springs. It is **NOT necessary** to disassemble the EXP halves to change springs! See the following chart for settings.

Engagement settings	Spring configuration
Low	6 Steel springs
Medium	3 Steel springs \ 3 Silver springs
High	6 Silver springs

## Changing the springs

1. Using a flat-blade screwdriver, push the ¼ turn pin in far enough to clear the opposite side of the EXP to unlock the pin.
2. With the pin still pushed past the base, turn 90° to remove the pin and spring.

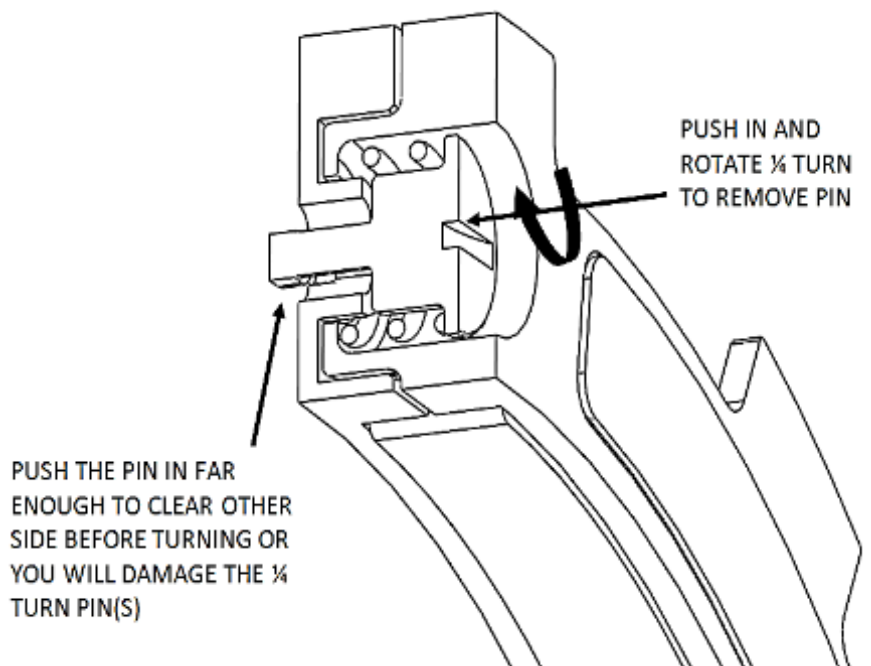

3. Remove the remaining 2 pins and springs from the same side of the EXP base.
4. Drop a new spring into the spring slot on the base, then add the ¼ turn pin.

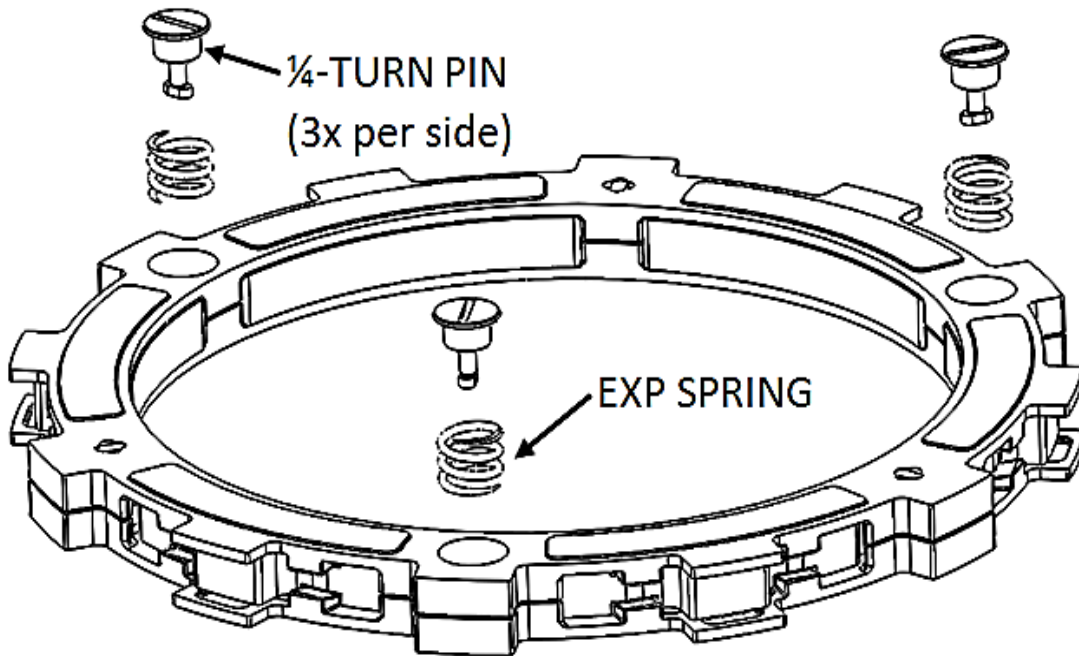

5. Push the turn pin in far enough to clear the base, then turn 90° and release the pin. The pin should sit almost flush with the EXP base.
6. Flip the EXP friction disk over and repeat on the other side depending on engagement preference.
7. If you need to disassemble the EXP disk, you can watch the video on our website under Tech Tips at [www.rekluse.com/support/videos/atv-mc-support-videos](http://www.rekluse.com/support/videos/atv-mc-support-videos).

**Note:** To maintain even pressure, when using two different color spring sets, install one set of 3 on one side of the EXP and the remaining set of 3 on the other side.

### **CAUTION**

**If you disassemble the EXP, the Teflon pads may fall out or be stuck to the ramp surfaces of the EXP bases. Take care to ensure all pads are correctly placed into wedge pockets using gentle pressure to avoid damage to the pad surfaces before reassembling the EXP. Properly seated pads will be secured in place once the EXP is reassembled. Operating the**



***clutch without the pads in place will cause part damage or failure.***

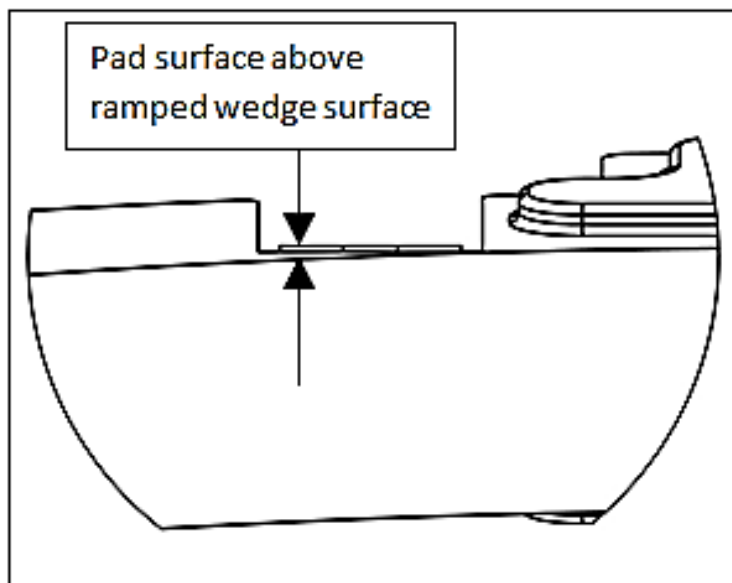
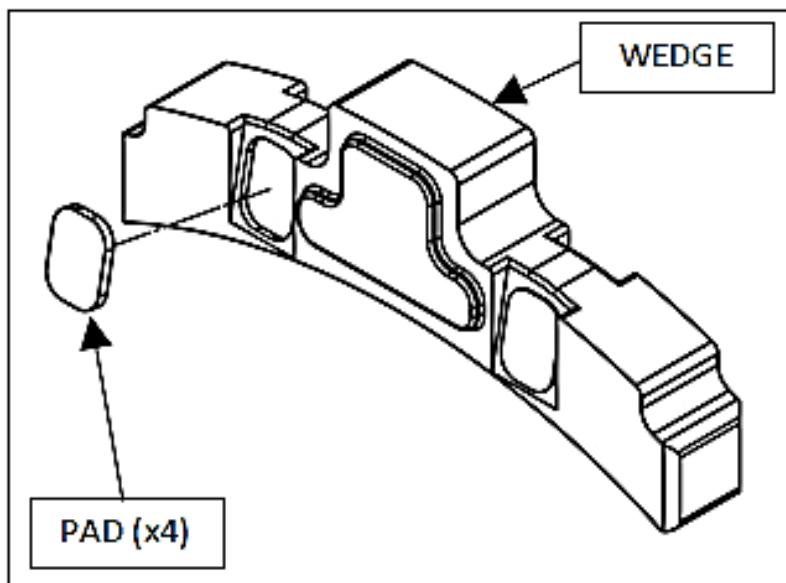

## **BUMP-STARTING**

If your bike needs to be bump-started due to a dead battery or any other reason, follow the steps below to quickly bump-start your bike.

1. Turn the adjustable slave cylinder counterclockwise to collapse the gap until no resistance is felt.
2. Bump start the bike. The clutch will function like a manual clutch at this point, but the clutch will not be fully over-ridable at high RPMs.
3. Once the bike is started, readjust the installed gap.

## **MAINTENANCE**

### **Clutch wear**

Rekluse clutches are built using high quality materials but do wear based on the rider's use, type of terrain, and natural wear and tear.

- Clutch longevity and performance is greatly increased with oil quality and other bike factors that reduce engine heat.
- Riding style, such as speed, engine RPM, and terrain can also effect the life of the clutch.

- To keep your clutch performing at its best, perform regular maintenance on your bike and clutch based on your riding style.
- Maintain adequate Free Play Gain. Check before every ride and adjust if necessary.

## Clutch parts

Inspect all of your clutch parts at regular intervals for signs of wear or excessive heat, and replace components as necessary.

- Repeat the break-in procedure anytime you replace the EXP bases, Teflon pads, EXP wedges, or frictions disks. Always soak friction disks or EXP bases in oil for at least 5 minutes before installing.
- Measuring the clutch pack can help determine if the components need replacing. The clutch pack is measured with the entire clutch pack together. Include the friction pad in the measurement.
- Disk inspection examples are found in the following section.
- Replace friction disks if the disks are glazed and/or burnt. Replace the drive plates if they show signs of excessive heat.

## Preventive Maintenance

- For optimal clutch performance Rekluse recommends using fresh, clean oil that **meets JASO-MA** oil rating requirements.
- Keep up with regular oil changes as per the bike manufacturer's recommendations. Clutch performance and longevity depend on oil quality.
- Change the oil filter and/or clean the oil screen with every oil change.

## Disk inspection examples:

When inspecting the clutch pack, the following pictures can be used as a reference. **These are best viewed in color by viewing this install document on our website at [www.rekluse.com/support](http://www.rekluse.com/support).**

**Drive Plates** – If the clutch pack is getting high amounts of heat, purple, blue, or black color can be seen on the drive plate teeth. See pictures below. Not all drive plates look the same and may look different than pictured.



Normal Heat

High Heat  
(Blue)

Excessive Heat  
(Black)

**Friction Disks** – Due to the dark color of the friction material, the friction disks will appear almost black as soon as they are put in oil. During inspection, look for glazing of the friction material. Glazing will appear shiny and feel like glass, even after oil is cleaned from the friction disk. Not all friction disks look the same and may look different than pictured.



Normal Friction



Glazed Friction

# **NEED ADDITIONAL HELP?**

## **Website**

[www.rekluse.com/support](http://www.rekluse.com/support)

## **Frequently Asked Questions**

[www.rekluse.com/faq](http://www.rekluse.com/faq)

## **Support Videos**

[www.rekluse.com/support/videos](http://www.rekluse.com/support/videos)

## **Phone**

(208) 426-0659

## **Technical Support**

Contact Technical Support for questions related to product installation, tuning, and performance.

Hours:

Monday thru Friday: 8:00 a.m. - 5:00 p.m.

Mountain Time zone

Email: [tech@rekluse.com](mailto:tech@rekluse.com)

## **Customer Service**

Contact Customer Service for additional product information, orders, and returns.

Hours:

Monday thru Friday: 8:00 a.m. - 5:00 p.m.

Mountain Time zone

Email: [customerservice@rekluse.com](mailto:customerservice@rekluse.com)



# SETUP SHEET 198-7913051

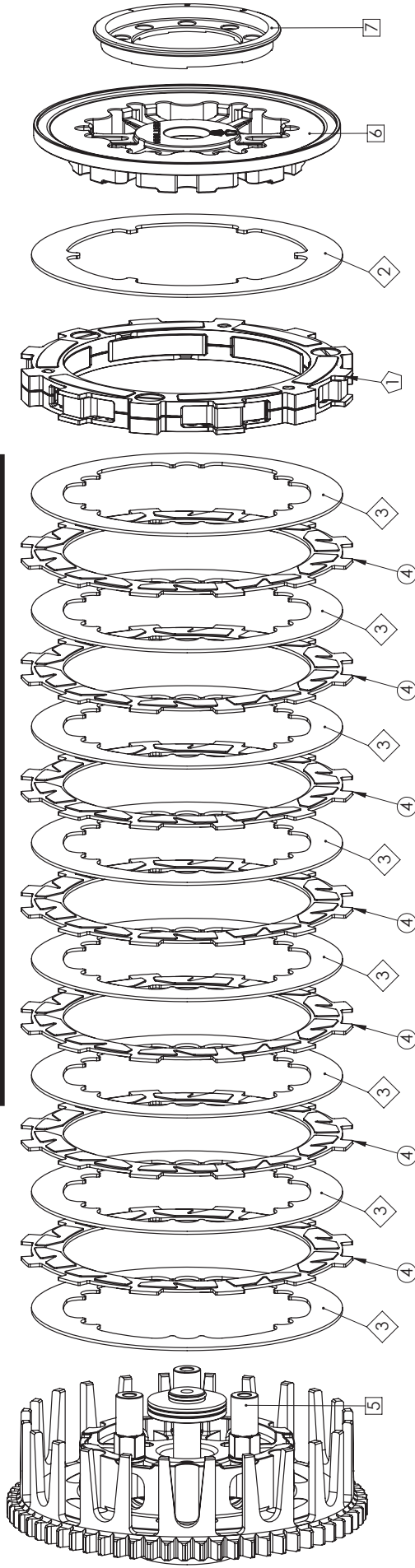

ITEM NO.	DESCRIPTION	QTY.
1	EXP DISK	1
2	LINING PLATE	1
3	DRIVE PLATE	8
4	FRICION DISK	7
5	CENTER HUB	1
6	PRESSURE PLATE	1
7	OEM SPRING RING	1

The OEM spring ring has different settings to account for variances in the clutch pack and wear. The optimal setting depends on the thickness of the clutch pack. In general, MORE preload on the spring results in LESS clamping force, which in turn provides a lighter lever pull and less aggressive clutch performance. LESS preload on the other hand provides MORE clamping force, a heavier clutch pull, and more aggressive clutch performance. The OEM spring ring has different settings to account for variances in the clutch pack and wear. Reference the "Spring Ring Optimization Table" for spring ring recommendations.

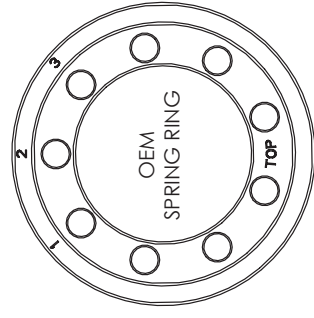

## CLUTCH PACK SPECS & SERVICE LIMITS

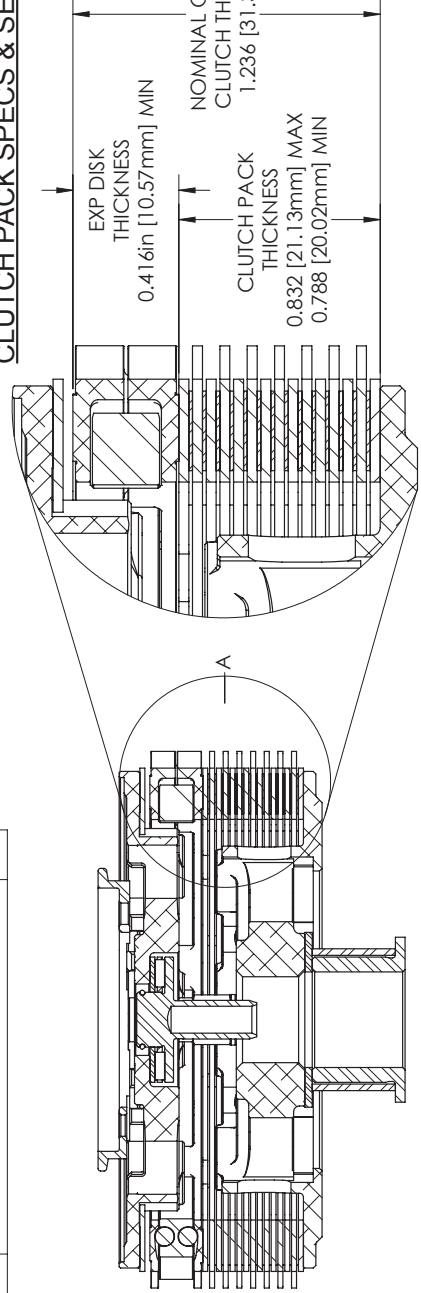

SPRING RING OPTIMIZATION TABLE	
CLUTCH PACK THICKNESS [IN]/[mm]	SPRING RING SETTING
1.204-1.229 [30.6-31.2]	3
1.230-1.242 [31.2 - 31.6]	2
>1.243 (>31.6)	1