

READ ME FIRST

Doc ID: 193-708A
Doc Revision: 060614

BASKET WEAR

The Rekluse TorqDrive clutch employs basket sleeves to protect the basket from wear caused by the friction disks. With the sleeves the basket will no longer notch, which may give the appearance that the basket is not wearing and does not need to be replaced. However, the rubber dampers in the basket assembly will still wear and will eventually break-down. This is a normal wear item that is usually evident by notching of the basket from the OE friction disks. Since the basket sleeves prevent notching, the basket and dampers should be inspected periodically to ensure good function. The basket should also be inspected for any fatigue cracking at the tang bases as worn dampers can increase the likelihood of cracks.

To inspect the dampers, rotate the ring gear and dampers back and forth in opposite directions. This is done best with the basket out of the engine. After removing the basket from the engine, hold the ring gear in one hand and the basket in the other and twist in opposite directions. If any rotational play can be felt between the basket and the ring gear, the dampers are worn and either the dampers or basket assembly need to be replaced. If worn dampers are not replaced, accelerated wear can occur to the rest of the clutch. The rotational play is sometimes accompanied by an audible “click” sound when rotating back and forth.

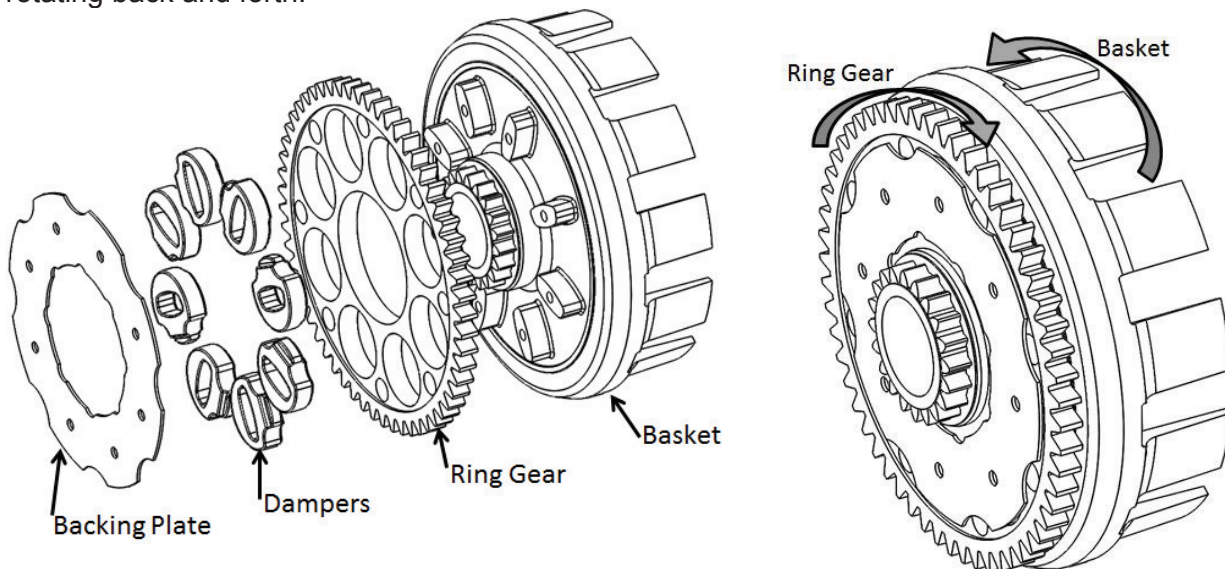

Rotate basket and ring gear in opposite directions
to check for any rotational play in the dampers

See the reverse of this page for more information.



12000 W Franklin Rd, Boise, ID U.S.A. 83709
Toll-Free (866) REKLUSE
Ph: (208) 426-0659
Fax: (208) 872-1318
www.rekluse.com

Before installation of the basket sleeves, ensure that the basket tangs are not notched. Notched basket tangs can cause failure of the basket sleeves that can lead to engine damage, bike damage, injury, and/or loss of life. See below image of an example of a notched basket that needs to be replaced.

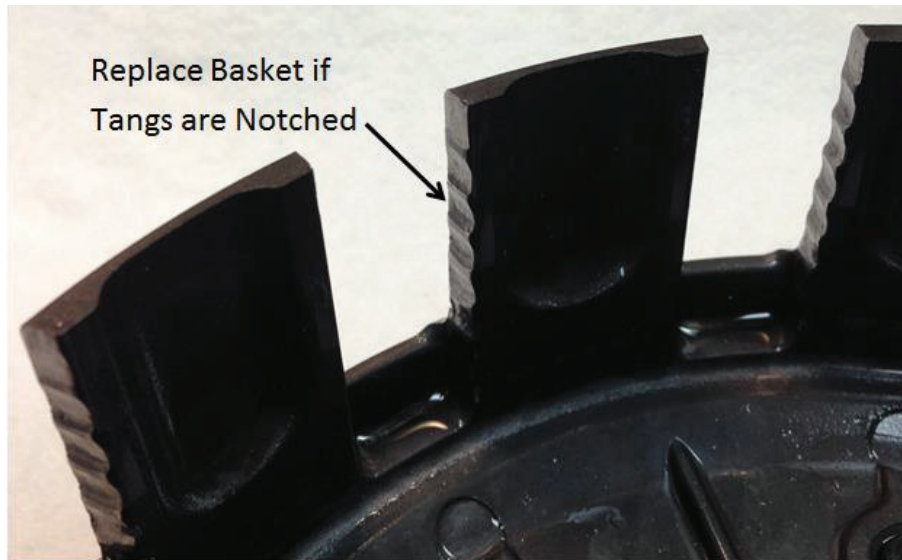

PRESSURE PLATE SPRINGS

The Rekluse TorqDrive clutch comes with two sets of pressure plate springs so the rider can choose to have either a lighter lever pull or more torque transfer through the clutch. **DO NOT** use higher force springs than those included in the kit. Clutch and/or engine damage could occur from higher force springs which could result in bike damage, injury and/or death.



REKLUSE[®]

TorqDrive

REKLUSE MOTOR SPORTS

The Rekluse TorqDrive[®] Kit

INSTALLATION GUIDE

Doc ID: 191-7100A

Doc Rev: 040919

OVERVIEW

- This kit will replace most of the OEM clutch parts, including the clutch pack. Only Rekluse Friction Disks can be used with the TorqDrive Product. For most models the clutch pack will have 12x friction disks and 12x Rekluse drive plates.
- The Rekluse clutch cover must be used with the TorqDrive product or interference could occur between the clutch cover and rotating clutch parts.

INSTALLATION TIPS

- Be sure to use proper eye protection
- Laying the bike on its left side allows for easy clutch access and eliminates the need to drain oil
- An air or electric impact wrench works well to remove the center clutch nut, or you can place the bike in top gear and hold the rear brake while loosening the center clutch nut with a socket
- Channel-lock style pliers work best to bend the tabs of the washer up over the center clutch nut
- See “Dirt TorqDrive Installation” video at Rekluse.com/videos.
- For optimal clutch performance Rekluse recommends using fresh, clean oil that meets JASO-MA oil rating requirements. Rekluse offers Factory Formulated Oil™ developed specifically for Rekluse products. Rekluse Factory Formulated Oil is a perfect complement to any OEM or aftermarket wet clutch. Visit www.rekluse.com to learn more.

TOOLS NEEDED

- 8mm socket
- Center Clutch Nut Socket (27-32mm)
- 5mm Allen Socket
- Torque wrench (in-lb & ft-lb, or N-m)
- Channel-lock pliers

INCLUDED PARTS

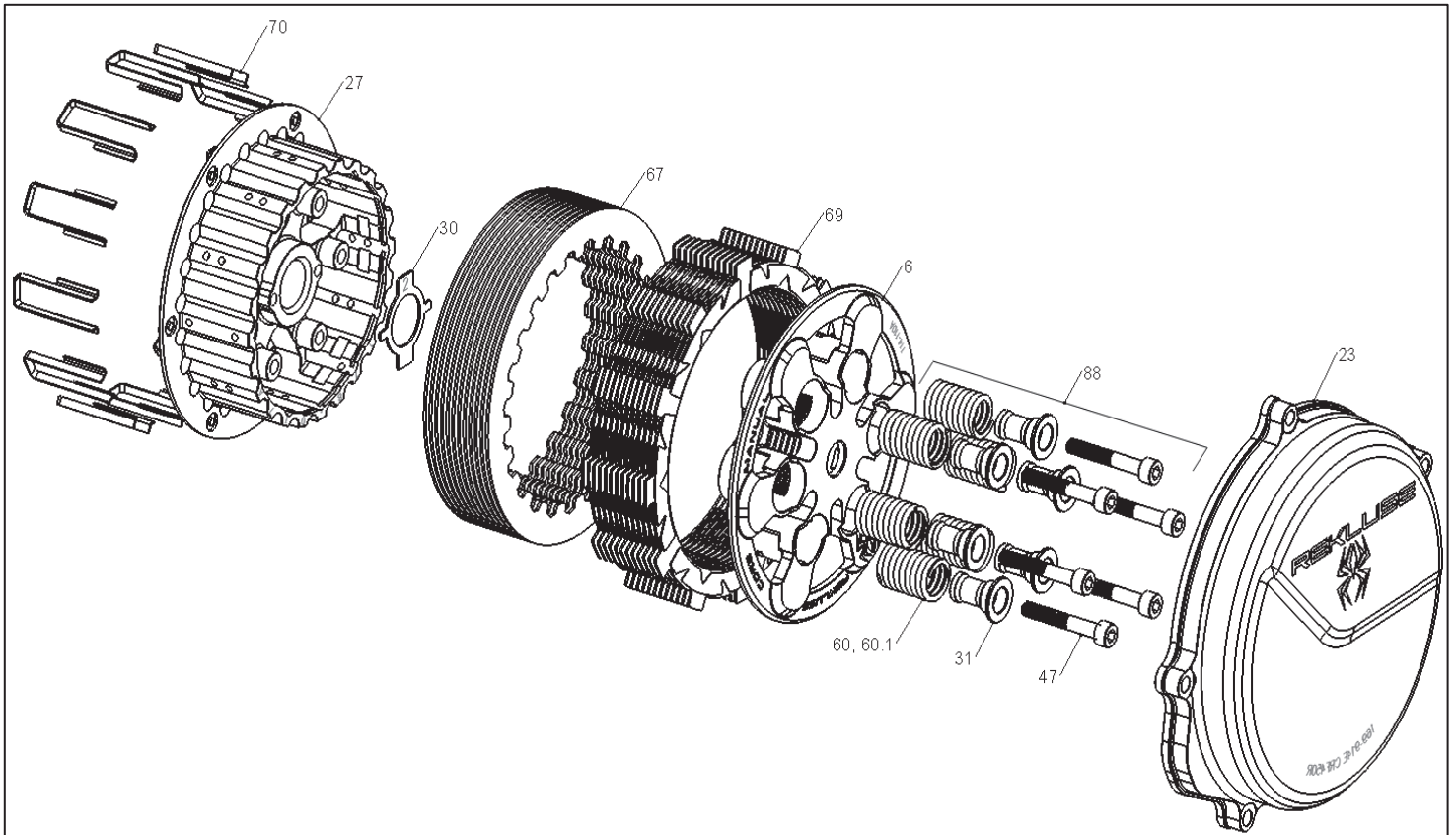

Item	Item Type	Qty
6	Pressure Plate	1
23	Clutch Cover	1
27	Center Clutch Hub	1
30	Lock Tab Washer	1
31	Screw Sleeve	6
47	Fastener – M6 Pressure Plate Bolt	6
60, 60.1	Pressure Plate Spring (10 for 250F, 12 for 450F/250 2-Stroke)	10,12
67	Steel Drive Plate	12
69	Thin Friction Disks	12
70	Basket Sleeves	12
88	Spring Kit	1

Visit Rekluse.com/support for a full parts fiche illustration and part numbers.

BIKE PREP & DISASSEMBLY

1. Soak the Rekluse friction disks in engine oil for 5 minutes.

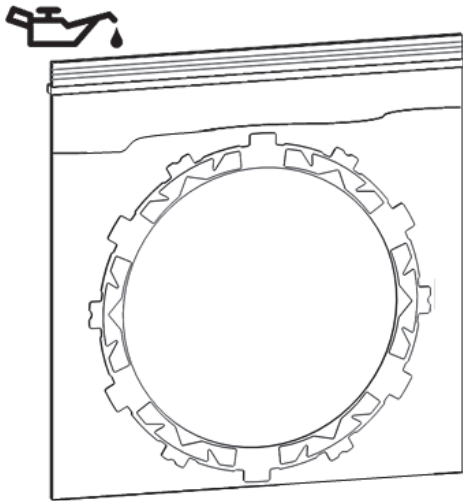

2. Lay the bike on its left side. Catch any fuel that might drain in a suitable container. Remove the clutch cover.



3. Remove the OEM clutch parts named in the following diagram down to the thrust washer. Leave the thrust washer installed in the basket.

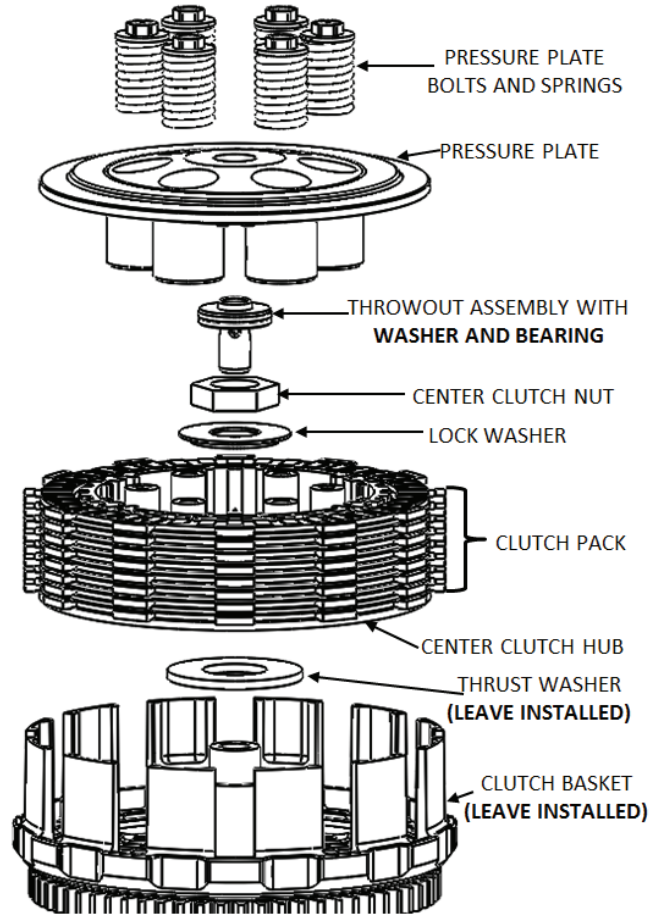

4. Inspect the basket for cushion slop or notching. If notched or worn, it is recommended to install a Rekluse Billet Clutch Basket (available for most models). See Read Me First for more inspection information. **Do not install sleeves or use product with a notched basket.**

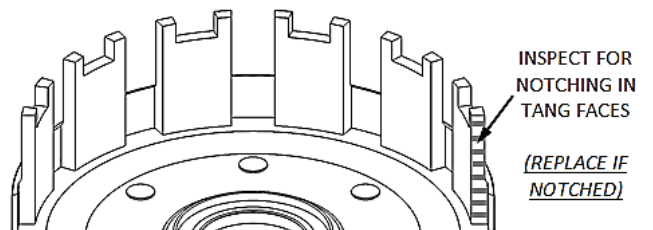

INSTALLATION

5. Install the Rekluse Center Clutch Hub, making sure the OEM thrust washer is in place.

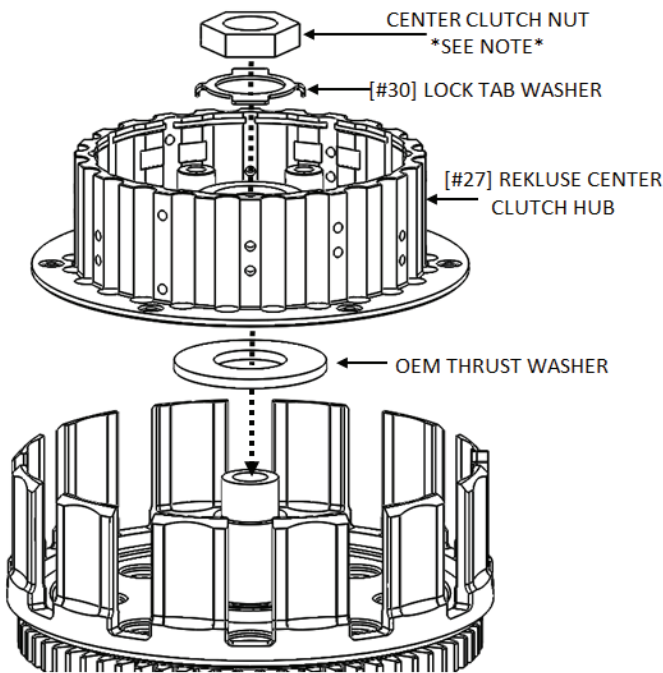

NOTES:

1. Be sure to use the Rekluse-supplied Lock Tab Washer [#30] when reinstalling, **not** the OEM Lock Washer.
2. **RMZ450, KX450F, KX250F:**
Install the included Rekluse Center Clutch Nut. Hex size = 1¼"(32mm).

All other models: Reuse the OEM Center Clutch Nut.

6. Torque the nut to **50 ft-lb (68 N-m)**, and bend up **both** tabs of the tab washer using channel-lock pliers. After torquing check to see that the center clutch rotates freely with the bike in neutral. Over-torquing the nut can cause excessive clutch drag.

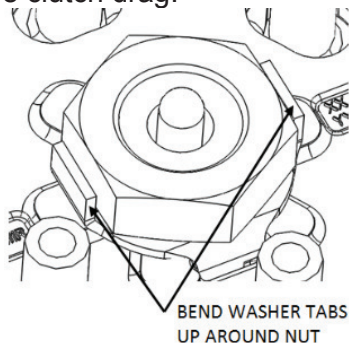

7. Install the [#70] Rekluse basket sleeves in the orientation shown making sure they are seated in the basket slots.

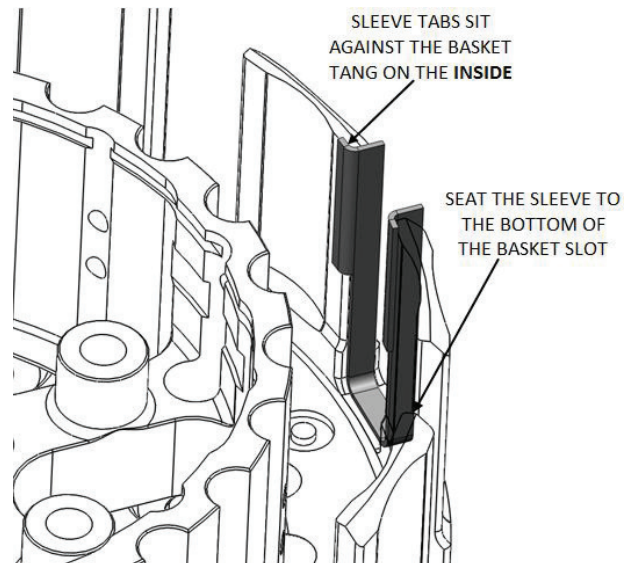
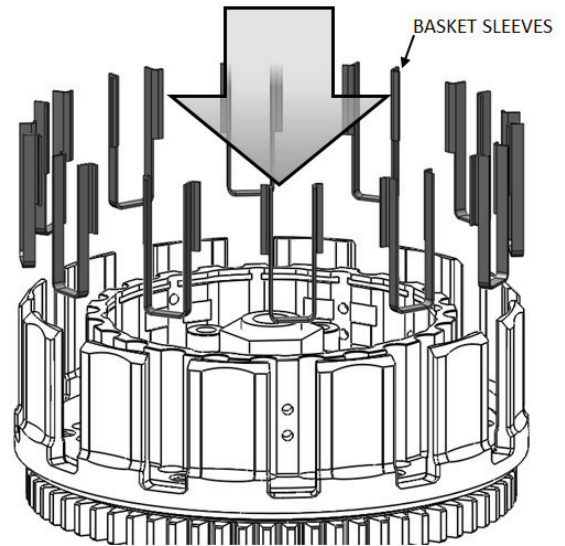

- NOTE:** When seated in the basket the sleeves may stick above or below the top of the basket.

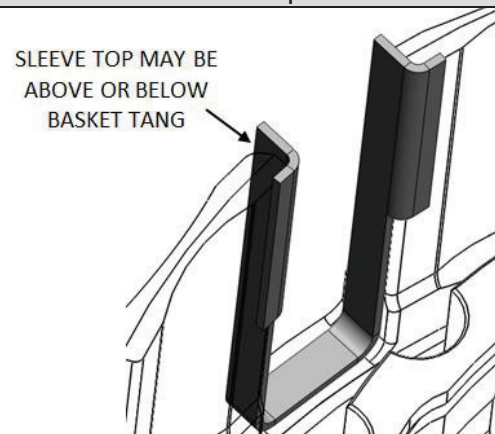

8. Install the clutch pack starting with a drive plate. Alternate drive plates and friction disks until all 12 drive plates and 12 frictions are installed ending with a friction disk. TIP: Use of picks can help keep the sleeves in place during installation. See video for more info.

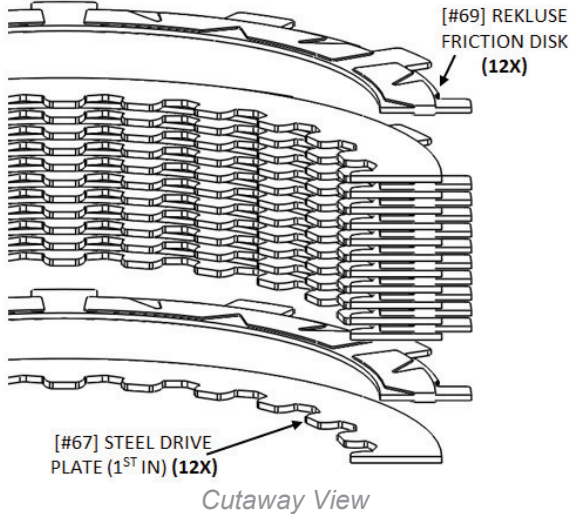
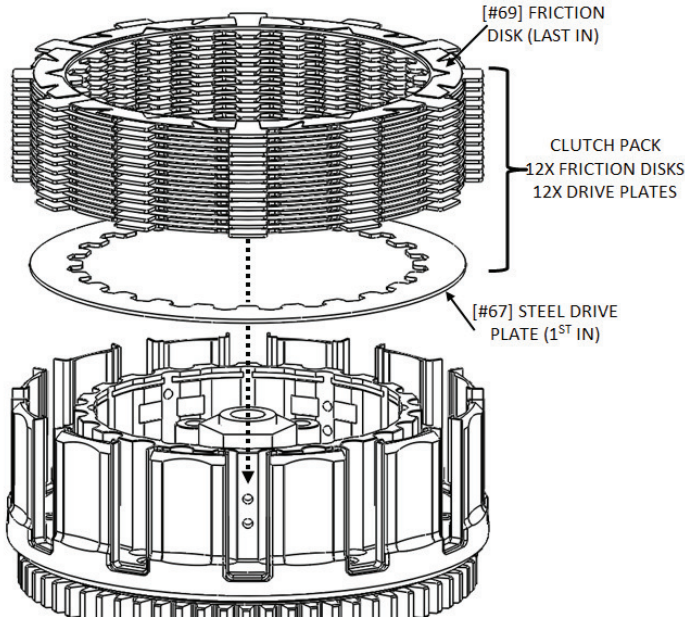

9. Reinstall the OEM throwout assembly **with washer and bearing**. The washer may have stuck to the OEM pressure plate.

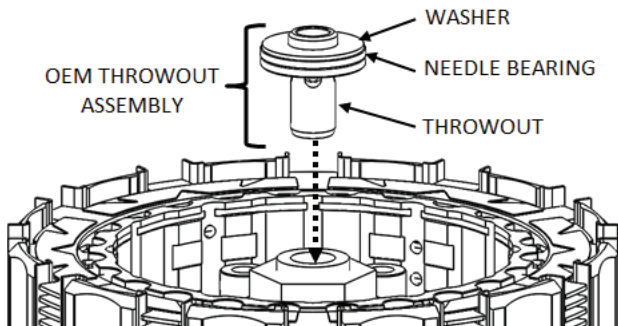

10. YZ125/250 2-Stroke: Install the included spacer on the OEM throw out.

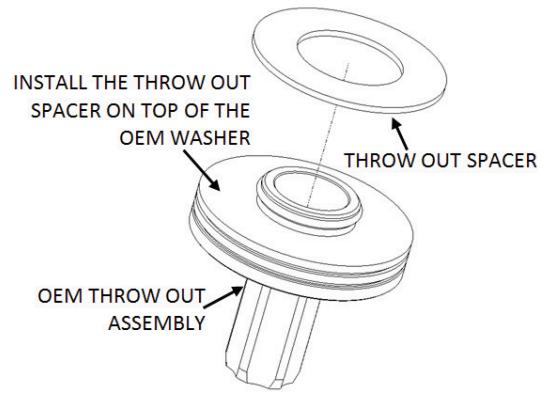

11. Install [#6] Rekluse Pressure Plate.

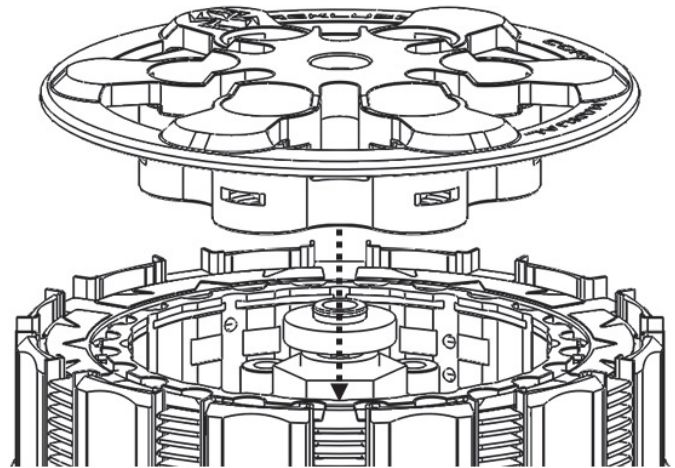

12. Install the Rekluse pressure plate springs and torque the pressure plate bolts. See next page for pressure plate spring information.

Do not reuse the OEM springs!

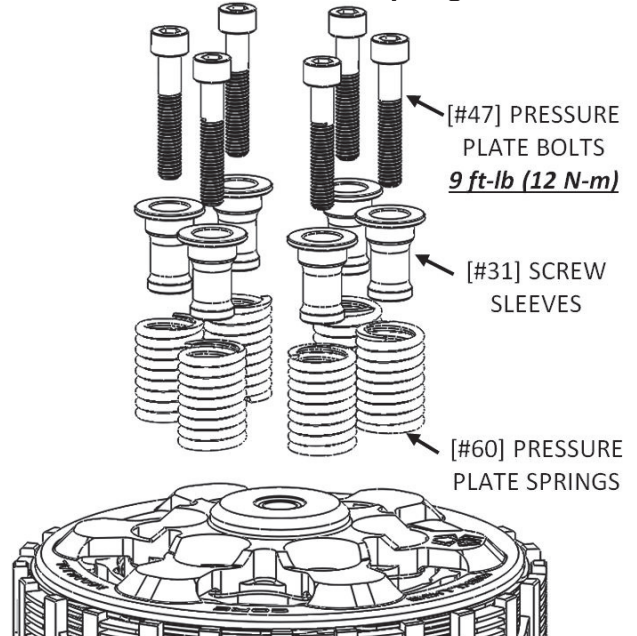

PRESSURE PLATE SPRING INFORMATION

Do not use higher force pressure plate springs than those included in the kit.

250F: There are two spring options. Silver springs will give the feel of a smoother clutch with a clutch lever pull about equal to OEM. Gold springs will yield a more aggressive clutch with clutch pull slightly higher than OEM. For best performance and clutch life, gold springs are recommended.

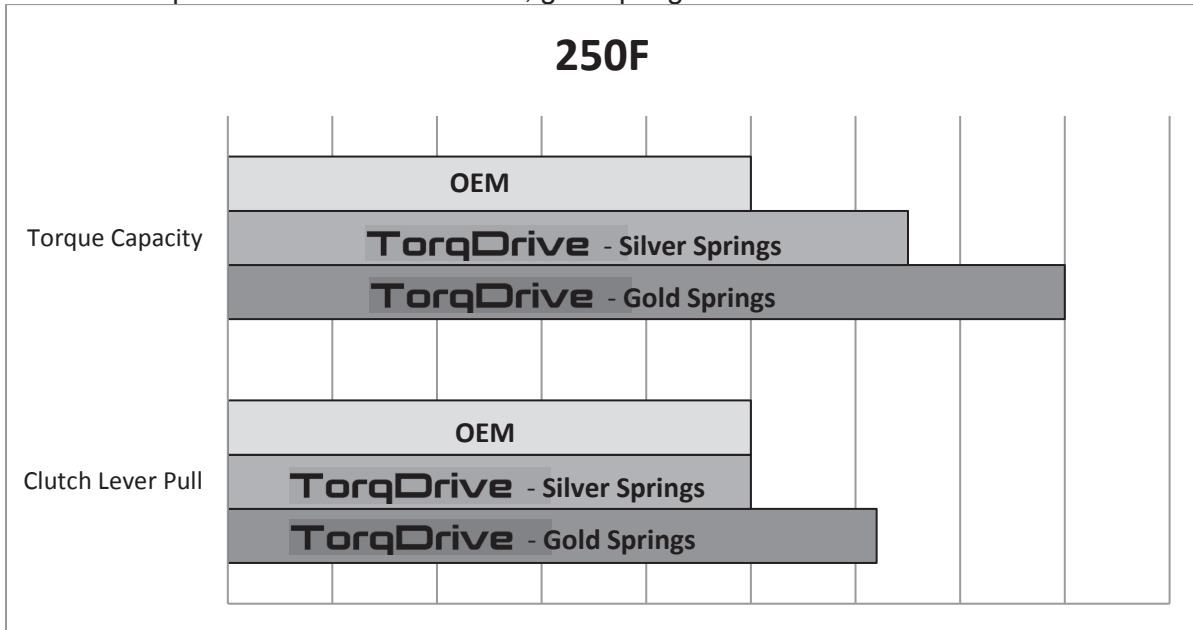

450F/250 2-Stroke: There are three spring options. Gold springs will give the feel of a smoother clutch with a clutch lever pull lighter than OEM. Red springs will yield a more aggressive clutch with clutch pull similar to OEM. Using three of each spring (3 red and 3 gold) will result in an in-between setup. Be sure to alternate springs when using 3 red and 3 gold to keep even pressure on the clutch. For best performance and clutch life, red springs are recommended.

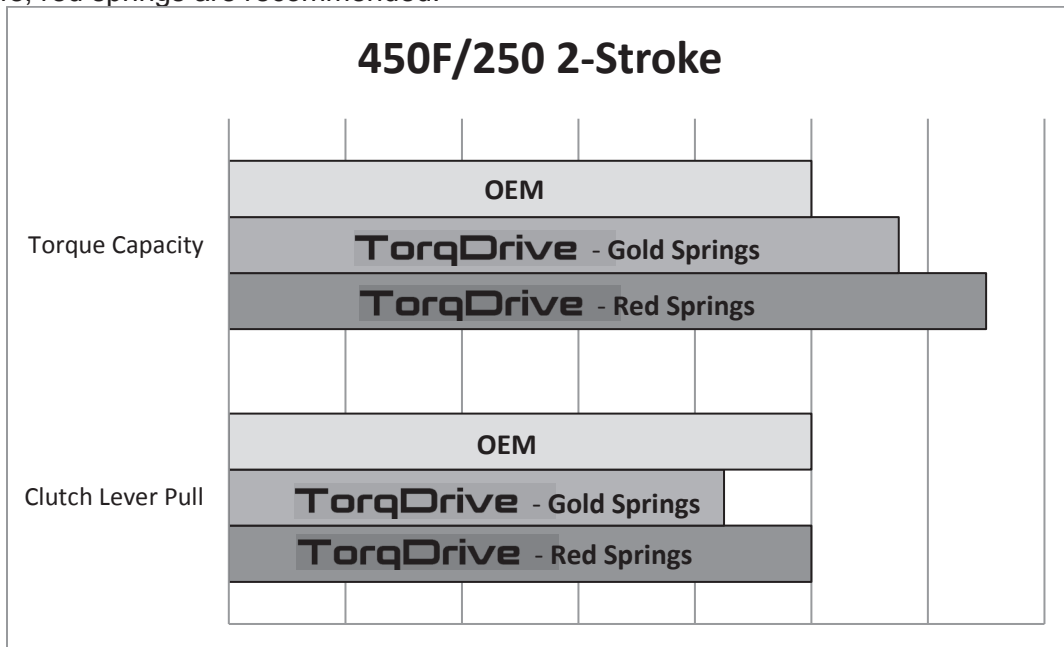

Charts are representative. Differences in clamping force and torque capacity will vary by model.

13. Install the Rekluse clutch cover, torquing the cover bolts to OEM specification. Reuse OEM clutch cover gasket.

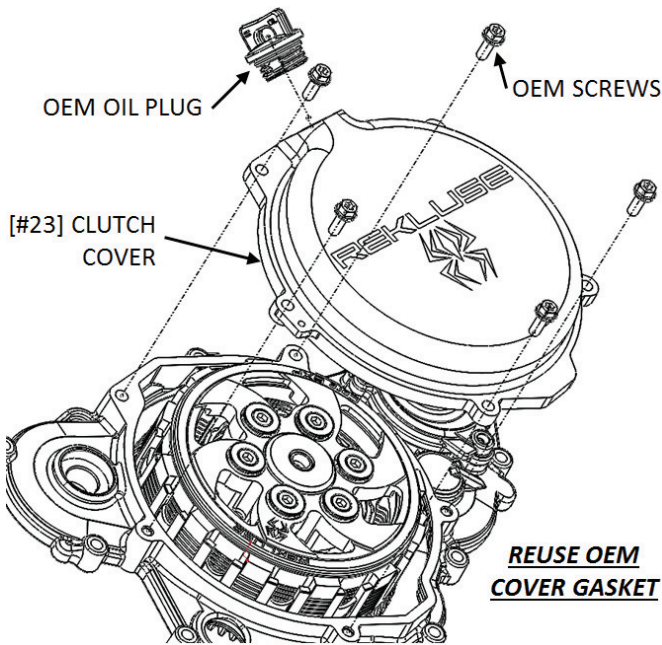

14. Readjust lever free play to OEM Specification or 10-20mm.



YZ 250 Two Stroke

To provide clearance between the cover and brake pedal, install the included brake pedal spacing washer (184-170) between the frame and brake pedal. Be sure to match the OEM torque specifications and reuse the OEM cotter pin. Rekluse recommends using a medium strength thread locking compound while reinstalling the OEM brake pedal bolt.

Honda TRX450 ATV All Models

To provide clearance between the cover and brake pedal, install the included brake pedal spacing washer between the frame and brake pedal. Be sure to match the OEM torque specifications. Rekluse recommends using a medium strength thread locking compound while reinstalling the OEM brake pedal bolt.

Honda TRX450 ATV Kick-Start Models

You must modify your kick-start lever to clear the clutch cover! Interference will occur with your kick-start lever unless it is modified similar to the photos below. Be sure not to damage the structural integrity of the lever. Rekluse will not warrantee a damaged clutch cover or kick-start lever.

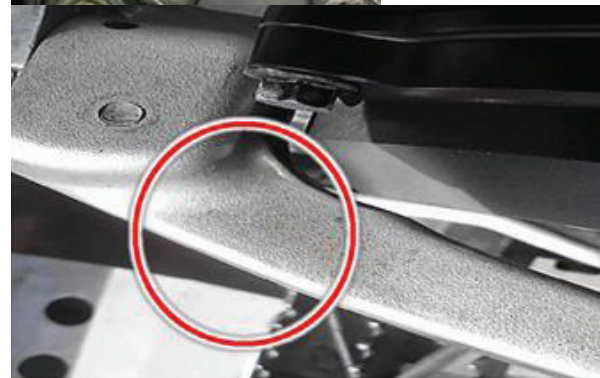

BREAK-IN

- Break-in will occur over the first 1-2 hours of use, depending on the rider. During break-in more clutch drag may occur than normal.

TROUBLE SHOOTING

Clutch Drag:

- Cold Drag Only – If drag occurs only while the bike is cold, oil is the most likely cause. Be sure to warm up the bike before riding/racing. Use of lighter weight oil can help to minimize cold drag.
- Hot and Cold Drag – Ensure that the center clutch nut is properly torqued so that the center clutch spins freely. Check for any warped or not flat plates in the clutch pack, either drive plates or frictions.

Clutch Slip:

- If clutch slip occurs, inspect the clutch for signs of wear or heat.
- Use of the heaviest springs included with the kit will reduce the chance of clutch slipping and/or excessive heat.

MAINTENANCE

- Inspect all of your clutch parts at regular maintenance intervals for signs of wear or excessive heat, and replace components as necessary. See Read Me First for clutch basket inspection information. Rekluse recommends inspecting at 5 hours of use, then every 10 hours after. Clutch wear is very dependent on the riders use, inspection interval may vary.
- Inspect and replace basket sleeves if they appear to be notched from friction disks. Rekluse recommends replacing them every 25 hours for abusive riding/racing, every 50 hours for moderate riding, or every time friction disks are replaced.
- Replace friction disks if they measure below **0.068" (1.73mm)** thickness or if they are glazed and/or burnt.

- Keep up with regular oil changes and other bike maintenance. Ultimately, better clutch longevity and performance is greatly increased with oil quality and other bike factors that reduce engine heat.

DISK EXAMPLES FOR INSPECTION

These are best viewed in color by downloading the PDF from Rekluse.com.

When inspecting the clutch pack, the following pictures can be used as reference:

Drive Plates – If the clutch pack is getting high amounts of heat, purple, blue, or black color can be seen on the drive plate teeth. See Pictures below.

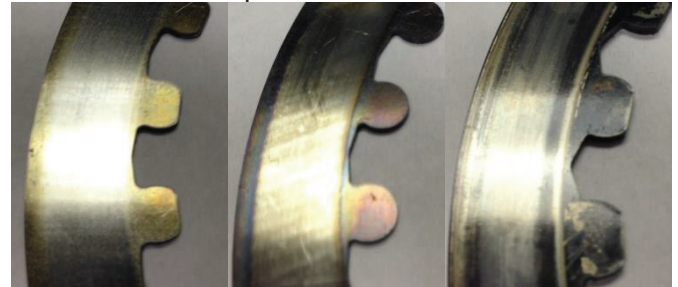

Normal Heat High Heat (Blue) Excessive Heat (Black)

Friction Disks – Due to the dark color of the friction material, the friction disks will appear almost black as soon as they are put in oil. During inspection, look for glazing of the friction material. Glazing will appear shiny and feel like glass, even after oil is cleaned from the friction disk.

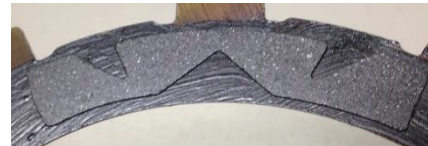

Normal Friction



Glazed Friction

REKLUSE



©2014 Rekluse Motor Sports
Rekluse Motor Sports, Inc.
customerservice@rekluse.com