



INSTALLATION & USER'S GUIDE

TorqDrive[®] Clutch Pack
for DS clutches

Doc ID: 191-2891A

Revision: 081319

TABLE OF CONTENTS

OVERVIEW	2
INSTALLATION TIPS	3
TOOLS NEEDED.....	3
INCLUDED PARTS	4
DISASSEMBLE THE CLUTCH	5
CLUTCH PACK INSTALLATION.....	7
Notes for installation.....	7
Install the clutch pack.....	7
Finish installation	10
MAINTENANCE.....	12
Disk inspection examples	13
TROUBLESHOOTING.....	14
Performance issues	14
Clutch noise	15
NEED ADDITIONAL HELP?.....	16

OVERVIEW

This kit replaces the OE (Original Equipment) clutch pack with a Rekluse TorqDrive® clutch pack. The following parts are replace:





- All OE steel drive plates will be replaced with Rekluse steel drive plates.
- All OE friction disks will be replaced with Rekluse TorqDrive® friction disks.

INSTALLATION TIPS



- Read the safety information sheet included with your kit.
- Protect eyes and skin – wear safety glasses and thin disposable work gloves.
- Read this entire document before performing any steps.
- Lay the motorcycle on its left side when replacing the clutch. This makes the clutch work easier and eliminates the need to drain the oil.
- For optimal clutch performance Rekluse recommends using fresh, clean oil that **meets JASO-MA** oil rating requirements. Rekluse offers Factory Formulated Oil™ developed specifically for Rekluse products. Rekluse Factory Formulated Oil is a perfect complement to any OEM or aftermarket wet clutch. Visit www.rekluse.com to learn more.
- **This clutch pack is not legal to race with in the AMA Limited or Stock class.**

TOOLS NEEDED

 4 mm	 5 mm	 8 mm
4 mm Hex Key	5 mm Hex Key	8 mm Socket
		
Torque Wrench	Fluid Catch Container	

INCLUDED PARTS

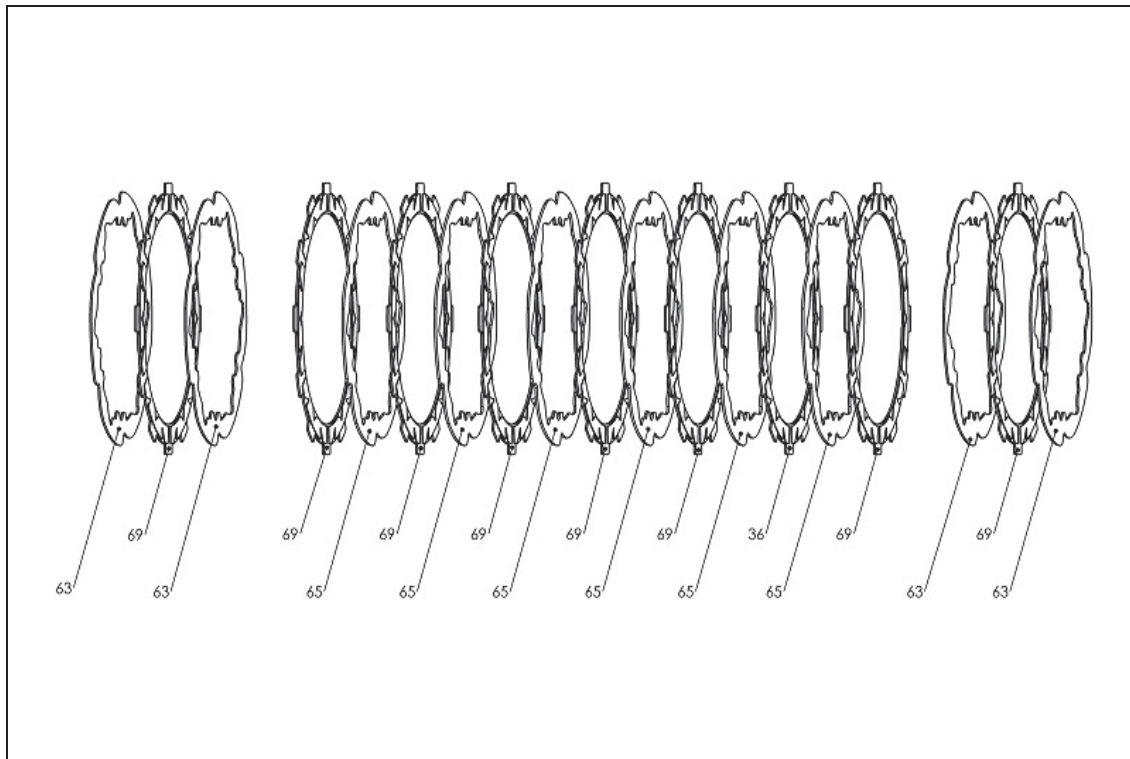

Item	Description	Qty.
63	Steel drive plates – .040” (1 mm)	6 or 7
65	Steel drive plates - .048” (1.2 mm)	2 or 3
69	TorqDrive® friction disks	9

Visit www.rekluse.com/support for a full parts fiche illustration and part numbers.

DISASSEMBLE THE CLUTCH

1. Turn the fuel petcock to “OFF” if applicable.
2. Lay the bike on its left side. Catch any fuel that might drain in a suitable container.

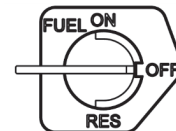

3. Use an 8 mm socket to remove the clutch cover. If your bike has an oil plug, loosen the plug before removing the cover.



4. Use an 8 mm socket to remove the following OE parts. When removing the Bellville spring, make sure to note the orientation of the spring. See following picture for reference.

- 6 pressure plate screws
- Pressure ring
- Belleville spring
- Slider ring
- Pressure plate
- OE clutch pack

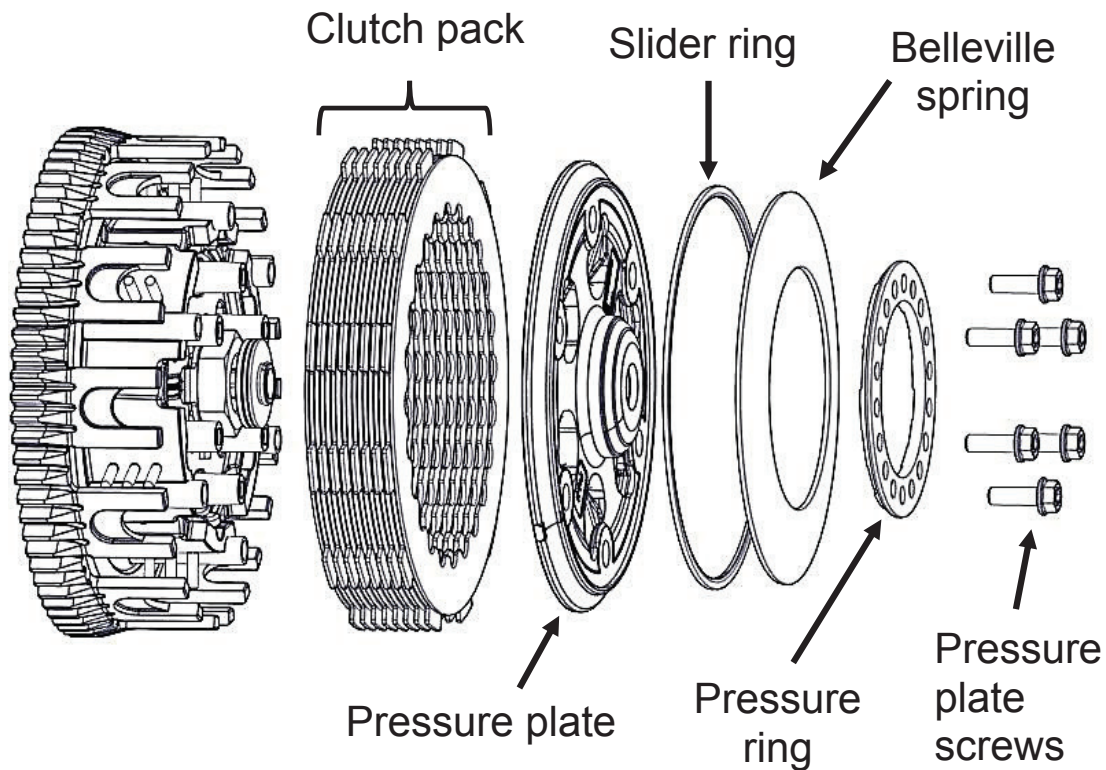

⚠ CAUTION

Be careful that the drive pins do not fall into the engine while disassembling.

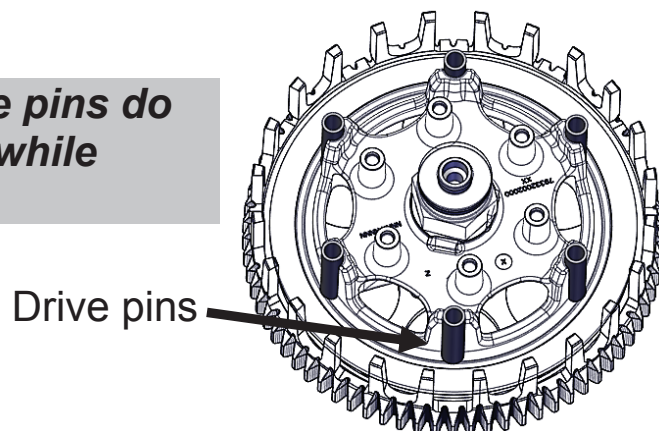

CLUTCH PACK INSTALLATION

Notes for installation

- Some friction disks are marked with a small colored dot. This mark is used for processing and can be ignored.
- The orientation of the clutch pack is different for each bike. The number and thickness of drive plates included in the kit also varies by bike. Please refer to the **Setup Sheet at the back of the manual** for specific information before installing the clutch pack.
- Some OE basket tangs have “half slots.” Rekluse products require the entire clutch pack be installed into the MAIN (deeper) basket slots. Installing the clutch pack into the “half slots” will cause performance issues. See the following picture for reference.

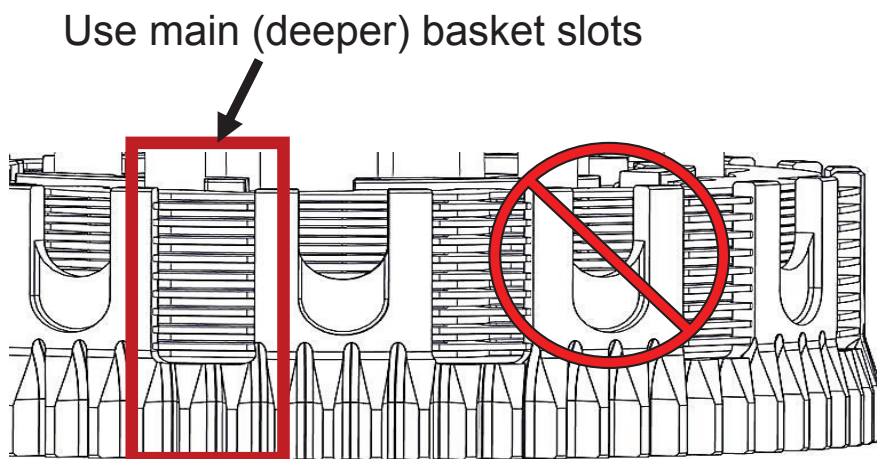

Install the clutch pack

1. Soak the friction disks in new oil for at least 5 minutes. Make sure the friction disks are coated on both sides.

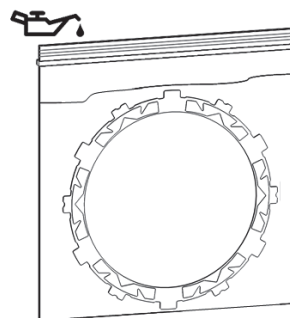

2. The steel drive plates included in your kit depend on your bike model.
 - a. If your kit includes regular steel drive plates, the direction does not matter.
 - b. If your kit includes TEC plates, ***install all the drive plates in the following orientation.***

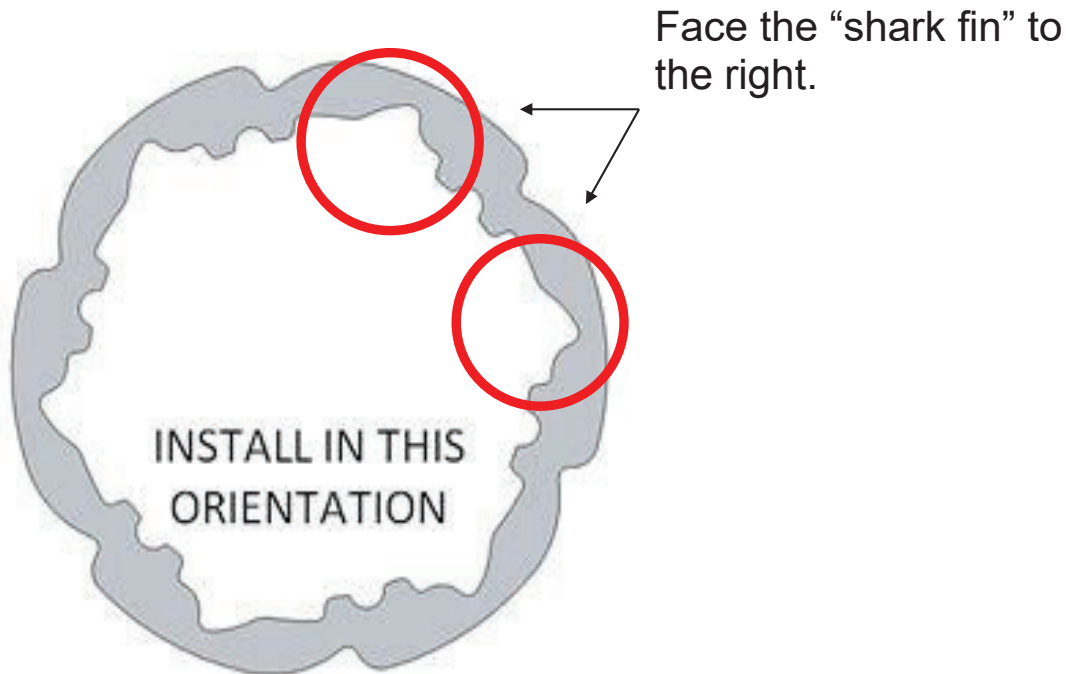

Note: Proper orientation of the drive plates is critical for optimal clutch performance. If you install them backwards the clutch will still function but will lack proper modulation performance.

- Align the drive pin notches in the drive plate with the drive pins on the hub, then install the drive plate into the basket. Be sure that the drive pins are seated in the notches and not in the bigger sections.

3. When installing the steel drive plates, **ALL** the plates must be aligned in the drive pins notches or damage may occur. The plates will not move when installed correctly.

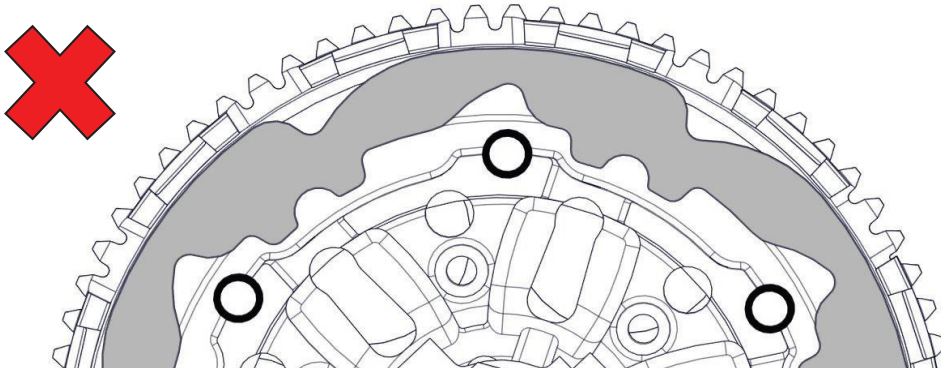
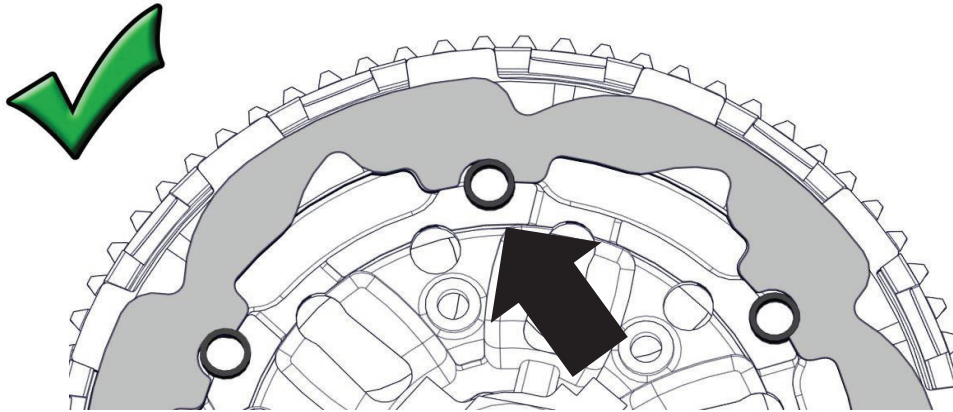

4. Install a steel drive plate into the basket being sure to position the drive plate according to your specific model.
5. On top of the steel drive plate, install a Rekluse friction disk, then install steel drive plate.
6. Continue to alternate Rekluse friction disks and steel drive plates according to the **Setup Sheet located at the back of the manual.**

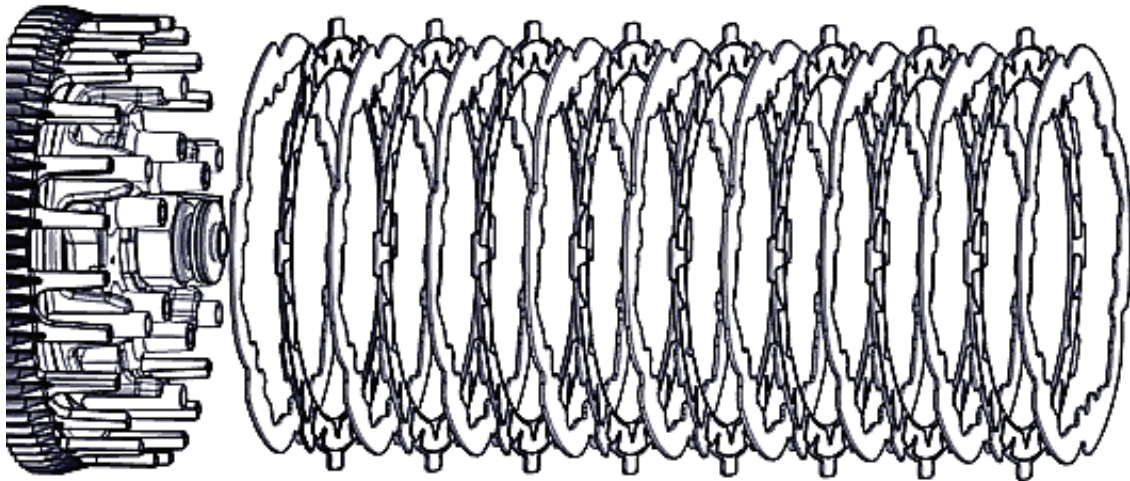

FINISH INSTALLATION

1. Reinstall the pressure plate.
2. Place the OE slider ring on the pressure plate with the “top” marking facing up. (The top side is rounded and the bottom edge is sharp.)



3. Place the OE Belleville spring onto the slider ring, with the rounded dome side facing up.

Note: *The outer edge of the Belleville spring will make contact with the slider ring. If it does not, the Belleville spring is upside down.*

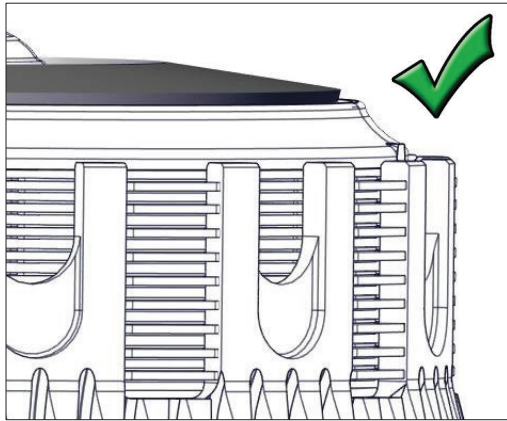

Correct – The Belleville spring sits flat against the slider ring.

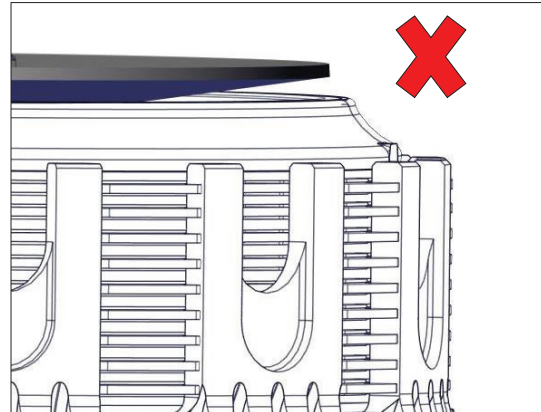

Incorrect – The Belleville spring is upside down.

4. Reinstall the pressure ring, flat side up.
5. Reinstall the pressure plate screws.

Note: *There are 3 possible settings on the OE pressure ring that will be reused with the Rekluse Clutch system. These settings will be listed as I, II, III or X, Y, Z depending on model. To select the correct setting, you must refer to the setup sheet for optimized performance. The thickness measurement of the Rekluse clutch pack will determine the setting to be used on the OE pressure ring.*

Clutch damage can occur if you do not use the correct OE pressure ring setting as stated in the Rekluse setup sheet.

6. Loosely tighten the screws in a star pattern, then torque them in a star pattern to **55 in-lb (6 N-m)**.

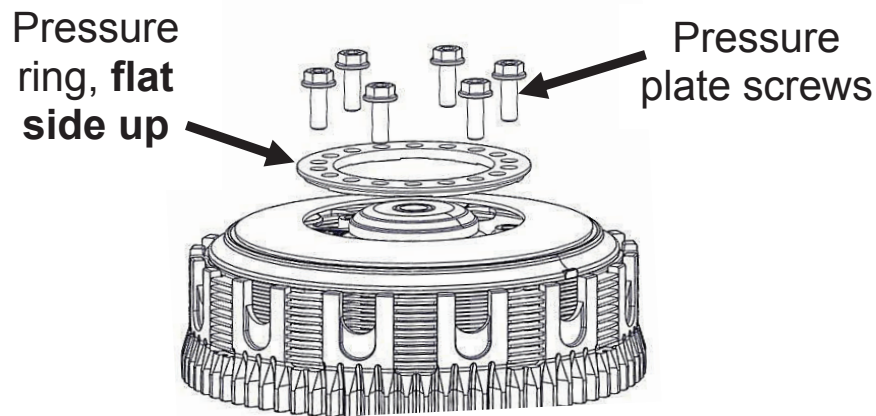

7. Reinstall the clutch cover by lightly tightening the cover bolts in a star pattern. Tighten bolts in small increments before torquing the cover bolts to OE specifications. *If your bike has an oil plug, tighten the oil plug.*

MAINTENANCE

To keep your clutch performing at its best, perform regular maintenance on your bike and clutch.

- Keep up with regular oil changes as per the bike manufacturer's recommendations. Clutch performance and longevity depend on clean oil.
- For optimal clutch performance Rekluse recommends using fresh, clean oil that **meets JASO-MA** oil rating requirements.
- Inspect all of your clutch parts for signs of wear or excessive heat and replace components as necessary. Clutch wear is dependent on the riders use.
- The OE spring ring can be optimized based on the wear and height of the clutch pack. See the attached **Setup**

Sheet for the spring ring optimization table to adjust the spring ring.

- Measuring the clutch pack can help determine if the components need replacing. See the **Setup Sheet** for the specific clutch pack measurements.
- Inspect the dampers, and replace them if you feel any movement between the two hubs. Refer to the section on inspecting the dampers for more information.
- Replace friction disks if they measure below specifications listed on the attached **Setup Sheet** or if the disks are glazed and/or burnt.
- Replace the drive plates if they show signs of excessive heat.

Disk inspection examples

When inspecting the clutch pack, the following pictures can be used as a reference. **These are best viewed in color by viewing this install document from www.rekluse.com/support.**

Drive Plates – If the clutch pack is getting high amounts of heat, purple, blue, or black color can be seen on the drive plate teeth. See pictures below. Not all drive plates look the same and may look different than pictured.



Normal Heat



High Heat
(Blue)



Excessive Heat
(Black)

Friction Disks – Due to the dark color of the friction material, the friction disks will appear almost black as soon as they are put in oil. During inspection, look for glazing of the friction material. Glazing will appear shiny and feel like glass, even after oil is cleaned from the friction disk. Not all friction disks look the same and may look different than pictured.

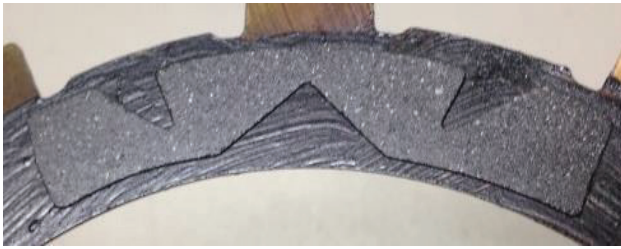

Normal
Friction



Glazed
Friction

TROUBLESHOOTING

Performance issues

If you find yourself adjusting the slave cylinder to fix Free Play Gain or drag, the clutch disks might be worn. Excessive heat or clutch slip can cause premature clutch failure as well. Once extreme temperatures are reached, irreversible damage will occur.

- Inspect all of your clutch parts for signs of wear or excessive heat, and replace components as necessary. Clutch wear is dependent on the riders use.
- Measuring the clutch pack can help determine if the components need replacing. See the attached Setup Sheet for the specific clutch pack measurements.

Clutch noise

Although it is harmless, some bike models may have “squeal” or “chatter” coming from the clutch at low RPM as it engages. Clutch squeal is caused by the clutch components vibrating as the clutch engages and can become more audible as the clutch gets hot. Adjusting the installed gap will NOT affect clutch squeal or chatter.

For bike models that have clutch squeal or chatter here are some recommendations to reduce or eliminate it:

- Change the oil: Rekluse recommends that you have fresh, clean oil that meets JASO-MA or JASO-MA2 standards for best clutch performance. Dirty or old oil can make the clutch more likely to squeal or chatter.

NEED ADDITIONAL HELP?

Website

www.rekluse.com/support

Frequently asked questions

www.rekluse.com/faq

Support Videos

www.rekluse.com/support/videos

Phone

(208) 426-0659

Technical Support

Contact Technical Support for questions related to product installation, tuning, and performance.

Hours:

Monday thru Friday: 8:00 a.m. - 5:00 p.m.

Mountain Time zone

Email: tech@rekluse.com

Customer Service

Contact Customer Service for additional product information, orders, and returns.

Hours:

Monday thru Friday: 8:00 a.m. - 5:00 p.m.

Mountain Time zone

Email: customerservice@rekluse.com



SETUP SHEET 198-2813181

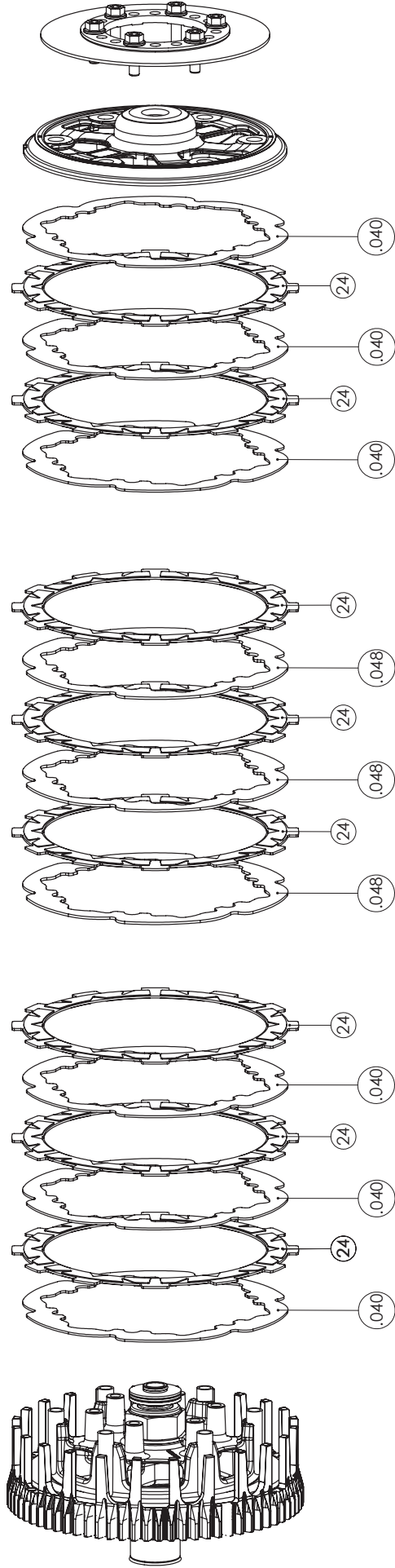

ITEM NO.	DESCRIPTION	QTY.
24	FRICITON DISK - TORQDRIVE	8
.040	DRIVE PLATE - .040" THICK	6
.048	DRIVE PLATE - .048" THICK	3

The OEM spring ring has different settings to account for variances in the clutch pack and wear. The optimal setting depends on the thickness of the clutch pack. In general, MORE preload on the spring (going to a lower numeric setting) results in LESS clamping force, which in turn provides a lighter lever pull and less aggressive clutch performance. LESS preload (going to a higher numeric setting) on the other hand provides MORE clamping force, a heavier clutch pull, and more aggressive clutch performance. See the "Spring Ring Optimization Table" for recommended optimized setting based on clutch pack thickness.

PACK THICKNESS [IN/mm]	SPRING RING SETTING
.954-.969 (24.2-24.6)	III OR Z
.941-.953 (23.9-24.2)	II OR Y
<.941 (<23.9)	I OR X

