

Polaris Generation 4 2" Rear Receiver Hitch

PART # 100645

Kit Components:

<u>Qty</u>	<u>Part Description</u>
1.....	2" Receiver
1.....	5/8"-11 X 1-1/2" HEX BOLT GR5 ZINC
1.....	5/8" SAE FLAT WASHER ZINC
1.....	5/8" LOCK WASHER



INSTALLATION INSTRUCTIONS:

1. Remove the factory nuts shown in Figure 1.
2. Place the receiver into location as shown in Figure 1&2. Line up the hole in the OEM hitch and the threaded boss on the receiver.
3. Run the factory A-Arm bolts through the hitch slots and re-assemble the nuts removed from Step 2.
4. Run the supplied 5/8 bolt through the lock washer, washer, OEM Ball hitch and into the threaded boss on the receiver as shown in figure 2.
5. Tighten all Hardware
6. Do not exceed recommended tongue or towing weight.

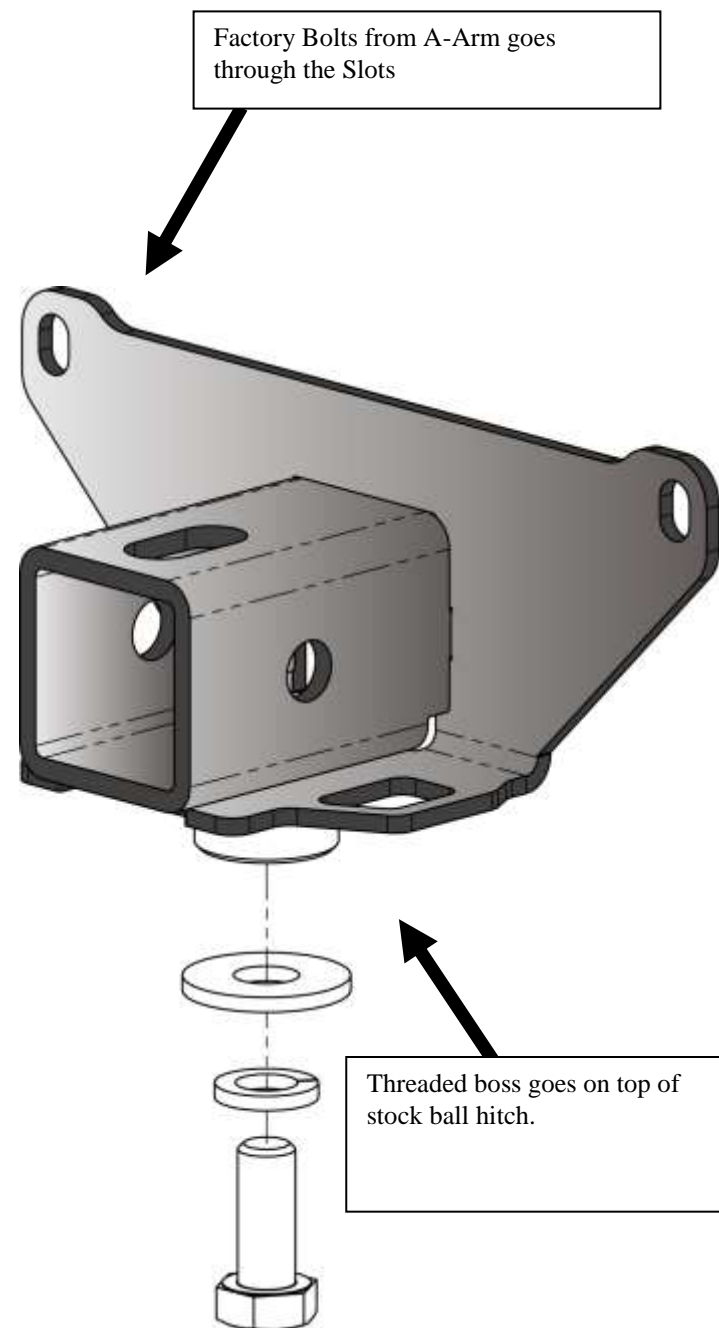

A-Arm Nuts



“Figure 1”