



16

BITTREE WAS ESTABLISHED IN 1978 WITH

THE GOAL OF PROVIDING HIGH-QUALITY PATCHING SYSTEMS TO THE BROADCAST, ENTERTAINMENT AND A/V INDUSTRIES. IN THE 35 YEARS SINCE THEN, WE'VE EARNED AN INTERNATIONAL REPUTATION FROM CUSTOMERS LIKE YOU FOR QUALITY, INNOVATION, AND CUSTOMER SATISFACTION.

INNOVATION / QUALITY / CUSTOMER SERVICE

HIGH-PERFORMANCE PATCHING SYSTEMS

VIDEO / 03

HIGH BANDWIDTH VIDEO: 03-14
COMPONENT VIDEO: 15-19



AUDIO / 20

TT BANTAM: 20-34
1/4" LONG-FRAME: 35-47



DATA / 51

RS422 PATCHBAYS: 48-53
FIBER & COPPER: 54-58
COAX & TWISTED PAIR: 59-62



INTEGRATED / 63

ACCESSORIES / 66



VIDEO

HIGH-BANDWIDTH

Bittree offers a full line of reliable high-bandwidth video patchbays, ideal for SD/SDI, HD/SDI, 3 Gb/s and 3-D applications. Housed in a solid, powder-coated aluminum panel and featuring the industry's finest fit-and-finish, our high-bandwidth video patchbays are available in Micro-Video, Mini-WECO and WECO formats.

The Micro-Video patchbay boasts the industry's highest-density format at 2x48, in either a 1 or 1.5 RU size. Mini-WECO patchbays feature a high-density 32 jacks per row, and are available in 1x32, 2x32 or 3x32 configurations; rack sizes include 1, 1.5 or 2 RU. Meanwhile, the more-spacious WECO patchbays feature 24, 26 or 28 jacks per row, and are available in 1, 2 or 3 row configurations; panel height include 1RU, 1.5RU or 2 RU.

Bittree's high-bandwidth video patchbays are designed for exceptional performance in high-bandwidth applications such as 3-D, HDTV, SDI, AES and high-resolution computer graphics, as well as in conventional analog applications such as monitor routing, primary routing, re-routing, router backup and video distribution. All standard Bittree video jacks are SMPTE 292M and SMPTE 424M compliant.

Notes on our Micro-Video, Mini-WECO and WECO formats: Most video patching systems in the U.S. use the WECO standard, developed by the Western Electric Company in the middle of the 20th century. WECO patchbays are usually considered easier to work with due to their spacious jack configuration (24-26-28 jacks per row), while Mini-WECO patchbays are ideal for higher-density patching (32 jacks per row). More recently, the demand for an even higher-density format led to the development of our Micro-Video Patchbay (48 jacks per row), which is ideal for small environments such as mobile production.



HIGH-BANDWIDTH

MICRO-VIDEO PATCHBAY

Our highest-density, high-bandwidth Micro-Video patchbays meet all SMPTE 292M and 424M specifications, and features DIN 1.0 / 2.3 rear terminations. In addition to the unparalleled performance of the video jacks, the design of the patchbay itself sets it apart from the competition in three ways. First, the patchbay features a lacing bar to help organize rack wiring. Second, the design provides an innovative option to recess the front panel and back to keep patchcords from protruding beyond the rack, saving space and ensuring snug connections in tight quarters. Third, the jacks are assembled to the patchbay with a captive front-mounting screw for easy maintenance.

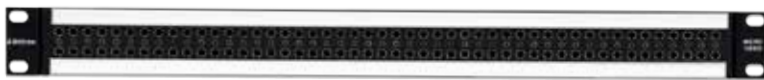

FRONT



REAR

HIGHEST-DENSITY MICRO
VIDEO FORMAT FEATURES
48 JACKS PER ROW

2X48 CONFIGURATION;
1 & 1.5 RU SIZES

HD/SDI, SD/SDI, 3GB/S
AND 3-D APPLICATIONS

SMPTE 292M AND SMPTE
424M COMPLIANT

FEATURES

- Highest-density video jack count available, 2 x 48
- High-bandwidth performance for SD/SDI, HD/SDI, 3 Gb/s and 3-D applications
- Available in 1 or 1.5 rack unit (RU) sizes
- Jacks conform to SMPTE 292M and SMPTE 424M
- True 75ohm impedance with low return loss
- DIN 1.0 / 2.3 rear termination
- Jacks are isolated from the front panel, and have a captive front-mounting screw for easy maintenance
- Integrated lacing bar helps organize rack wiring
- Front panel can be recessed back 1" to reduce patchcord protrusion beyond the rack
- Panels made from solid, powder-coated aluminum
- Extra wide designation strips

OPTIONS

Jacks maybe ordered in four different configurations:

- Dual-body self-normaling, terminating (2MVTHD)
- Dual-body self-normaling, non-terminating (2MVNHD)
- Dual-body non-normaling, terminating (1MVTHD)
- Dual-body non-normaling, non-terminating (1MVNHD)

HIGH-BANDWIDTH

MICRO-VIDEO PATCHBAY

JACK SCHEMATICS

FULL-NORMAL / TERMINATING (2MVTHD)

Features a dual-body video jack. Signal flows through jack in un-patched state. When a patchcord is inserted, the signal path follows the patchcord, and the opposite side of the jack is terminated with a 75 Ohm resistor.

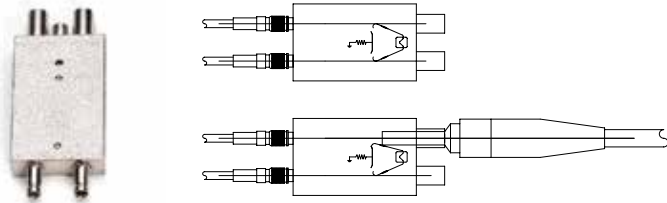

NON-NORMAL / TERMINATING (1MVTHD)

Features a dual-body video jack. When a patchcord is inserted, the signal path follows the patchcord. When patchcord is removed, circuit is terminated with a 75 Ohm resistor.

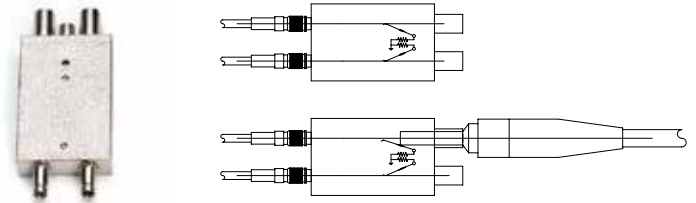

FULL-NORMAL / NON-TERMINATING (2MVNHD)

Features a dual-body video jack. Signal flows through jack in un-patched state. When a patchcord is inserted, the signal path follows the patchcord.

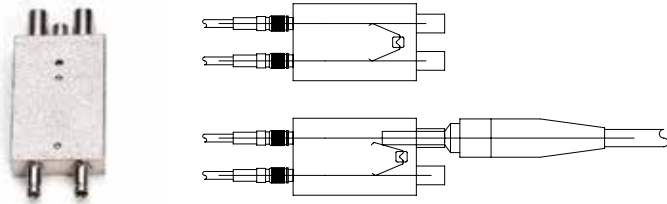

NON-NORMAL / NON-TERMINATING (1MVNHD)

Features a dual-body video jack. When a patchcord is inserted, the signal path follows the patchcord.

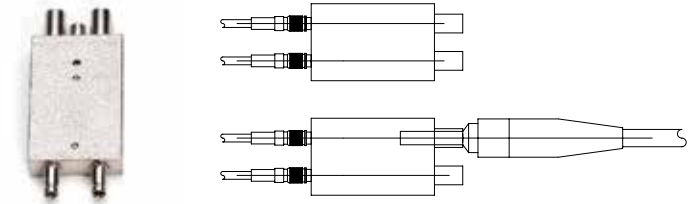

INSERTION LOSS / RETURN LOSS / SMITH CHART



INSERTION LOSS DIAGRAM

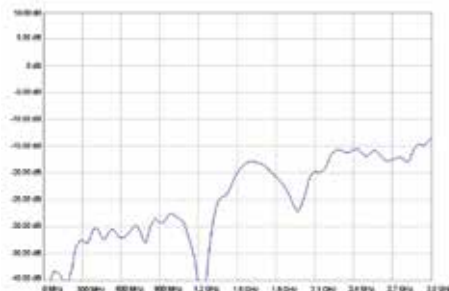

RETURN LOSS DIAGRAM

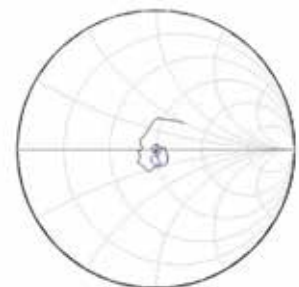

SMITH - Start: 30KHz / Stop:3.0GHz

HIGH-BANDWIDTH MICRO-VIDEO PATCHBAY

CODES / PATCHCORDS

MICRO-VIDEO ORDERING CODES

(B 96 S - 2 MV T HD)

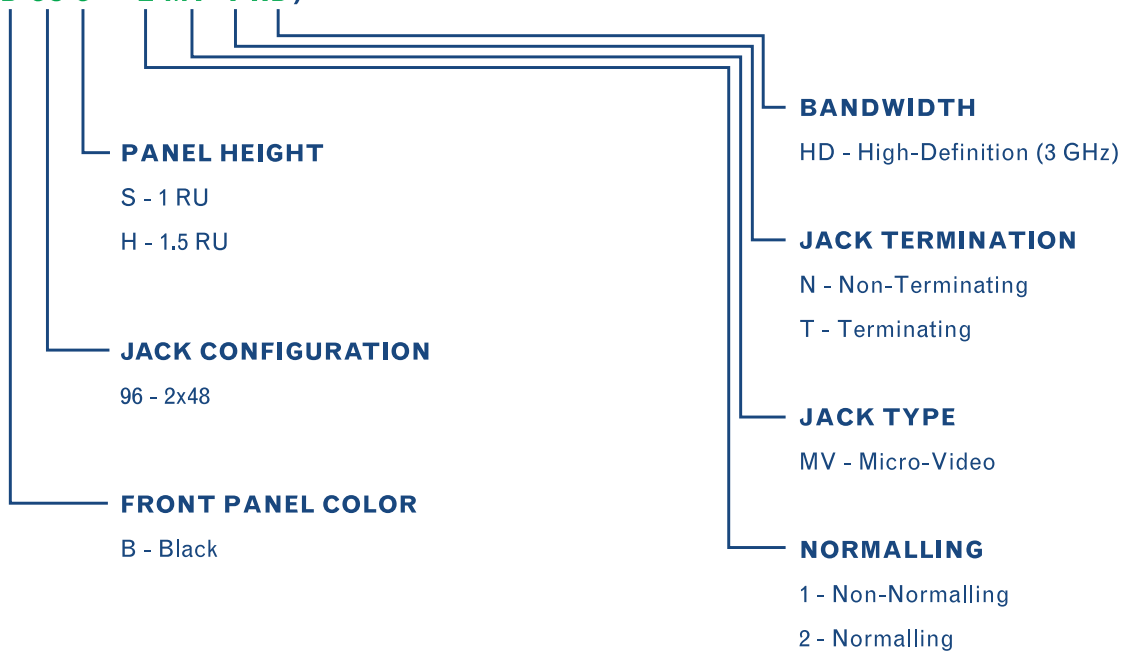

MICRO-VIDEO PATCH CORDS

(VPCMV 24 00 - 75)



Other lengths and colors available upon request

HIGH-BANDWIDTH

MINI-WECO PATCHBAY

Our wide range of Mini-WECO Video high-bandwidth patchbays are designed to meet all of your patching needs, from high bit-rate digital signals to base-band analog. Bittree Mini-WECO video patchbays are ideal for high-bandwidth applications such as HDTV, SDI, AES and high-resolution computer graphics, as well as in conventional analog applications such as monitor routing, primary routing, re-routing, router backup and video distribution.



FRONT



REAR

HIGH-DENSITY
MINI-WECO FORMAT
FEATURES 32 JACKS
PER ROW

1x32, 2x32 or 3x32
CONFIGURATIONS;
1, 1.5, OR 2 RU SIZES

HD/SDI, SD/SDI, 3GB/S
AND 3-D APPLICATIONS

SMPTE 292M AND SMPTE
424M COMPLIANT

FEATURES

- Highest-density video jack count of 32 per row
- High-bandwidth performance for SD/SDI, HD/SDI, and 3 Gb/s applications
- Jacks conform to SMPTE 292M and SMPTE 424M
- True 75ohm impedance with low return loss
- Panels made from 3/16" solid aluminum
- Staggered BNC rear interface
- Durable, scratch-resistant powder-coat finish
- Jacks are isolated from the panel
- Video panel can be configured 1x32, 2x32, or 3x32
- Available in 1, 1.5, or 2 rack units (RU)
- Black or gray front panel

OPTIONS

Jacks maybe ordered in four different configurations:

- Dual-body self-normaling, non-terminating (2MWNHD)
- Dual-body self-normaling, terminating (2MWTHD)
- Single-body or dual-body non-normaling, terminating (1MWTHD)
- Single-body non-normaling, non-terminating (1MWNHD)

HIGH-BANDWIDTH

MINI-WECO PATCHBAY

JACK SCHEMATICS

FULL-NORMAL / TERMINATING (2MWTHD)

Features a dual-body video jack. Signal flows through jack in un-patched state. When a patchcord is inserted, the signal path follows the patchcord, and the opposite side of the jack is terminated with a 75 Ohm resistor.

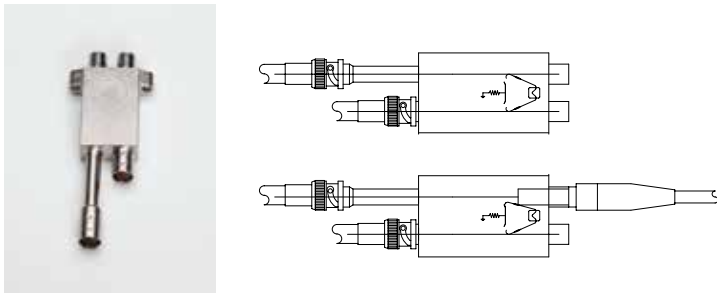

NON-NORMAL / TERMINATING (1MWTHD)

Features a single-body or dual-body video jack. When a patchcord is inserted, the signal path follows the patchcord. When patchcord is removed, circuit is terminated with a 75 Ohm resistor.

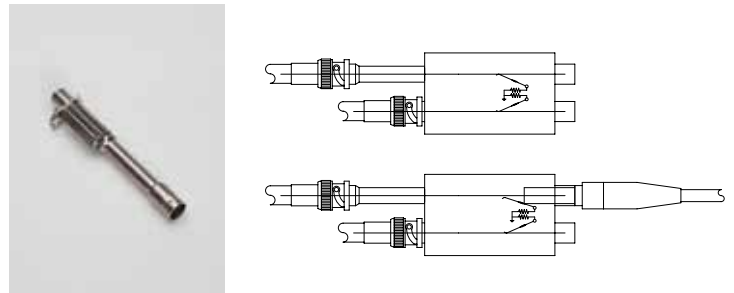

FULL-NORMAL / NON-TERMINATING (2MWNHD)

Features a dual-body video jack. Signal flows through jack in un-patched state. When a patchcord is inserted, the signal path follows the patchcord.

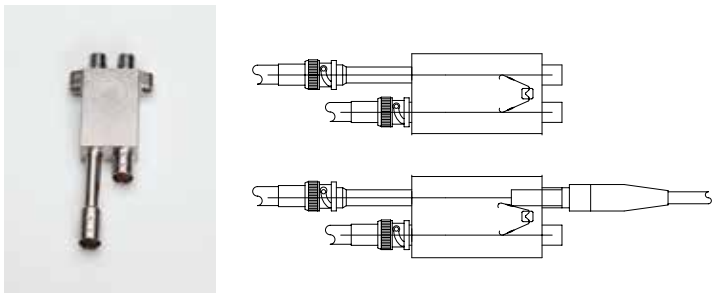

NON-NORMAL / NON-TERMINATING (1MWNHD)

Features a single-body video jack. When a patchcord is inserted, the signal path follows the patchcord.

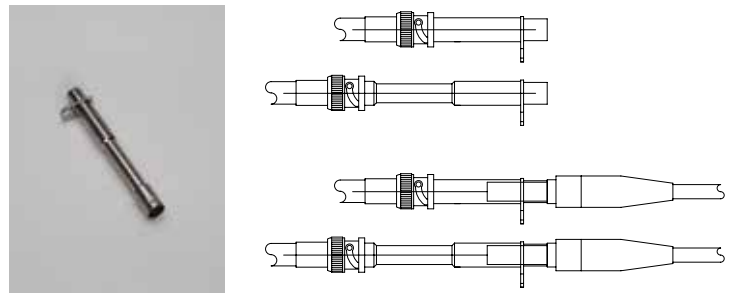

INSERTION LOSS / RETURN LOSS / SMITH CHART

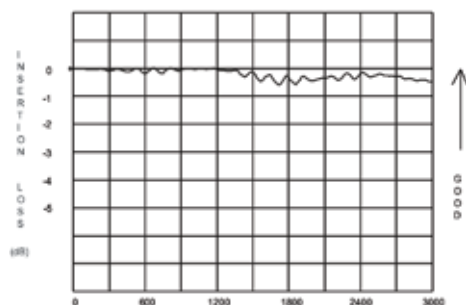

INSERTION LOSS DIAGRAM

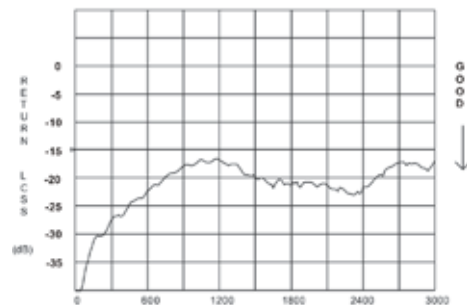

RETURN LOSS DIAGRAM

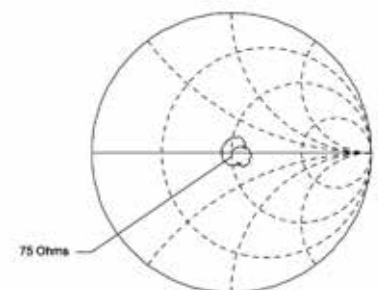

SMITH - Start: 30KHz / Stop:3.0GHz

HIGH-BANDWIDTH

MINI-WECO PATCHBAY

CODES / PATCHCORDS

MINI-WECO ORDERING CODES

(B 64 T - 2 MW T HD)



MINI-WECO PATCH CORDS

(VPCM 24 00 -75)

LENGTH BY INCH (CM)	COLOR
24 (61)	00 - Black
36 (92)	02 - Red
48 (122)	04 - Yellow
60 (153)	05 - Green
72 (184)	06 - Blue
	07 - Purple



MINI-WECO LOOPING PLUGS

(LPM 75 06)



HIGH-BANDWIDTH

WECO PATCHBAY

Our wide range of WECO Video high-bandwidth patchbays are designed to meet all of your patching needs, from high bit-rate digital signals to base-band analog. Bittree WECO video patchbays are ideal for high-bandwidth applications such as HDTV, SDI, AES and high-resolution computer graphics, as well as in conventional analog applications such as monitor routing, primary routing, re-routing, router backup and video distribution.



FRONT



REAR

SPACIOUS WECO FORMAT
FEATURES 24, 26, OR 28
JACKS PER ROW

1, 2, OR 3 ROW
CONFIGURATIONS;
1, 1.5, OR 2 RU SIZES

HD/SDI, SD/SDI, 3GB/S
AND 3-D APPLICATIONS

SMPTE 292M AND SMPTE
424M COMPLIANT

FEATURES

- High-bandwidth performance for SD/SDI, HD/SDI, 3 Gb/s and 3-D applications
- Jacks conform to SMPTE 292M and SMPTE 424M
- True 75ohm impedance with low return loss
- Panels made from 3/16" solid aluminum
- Durable scratch-resistant powder-coat finish
- Jacks are isolated from the panel
- Extra wide designation strips
- Spacious video jack counts of 24, 26, or 28 jacks per row in one or two row configurations
- Available in 1, 1.5, or 2 rack units (RU)
- Black or gray front panel

OPTIONS

Jacks maybe ordered in four different configurations:

- Dual-body self-normaling, terminating (2WTHD)
- Dual-body self-normaling, non-terminating (2WNHD)
- Single-body or dual-body non-normaling, terminating (1WTHD)
- Single-body non-normaling, non-terminating (1WNHD)

HIGH-BANDWIDTH WECO PATCHBAY

JACK SCHEMATICS

FULL-NORMAL / TERMINATING (2WTHD)

Features a dual-body video jack. Signal flows through jack in un-patched state. When a patchcord is inserted, the signal path follows the patchcord, and the opposite side of the jack is terminated with a 75 Ohm resistor.

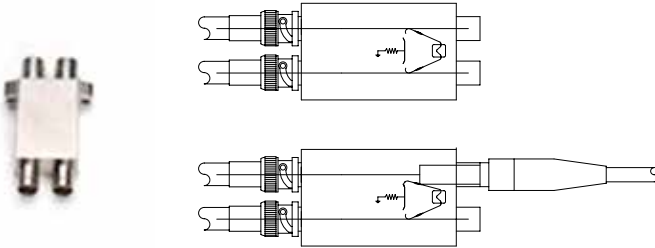

NON-NORMAL / TERMINATING (1WTHD)

Features a dual-body or single-body video jack. When a patchcord is inserted, the signal path follows the patchcord. When patchcord is removed, circuit is terminated with a 75 Ohm resistor.

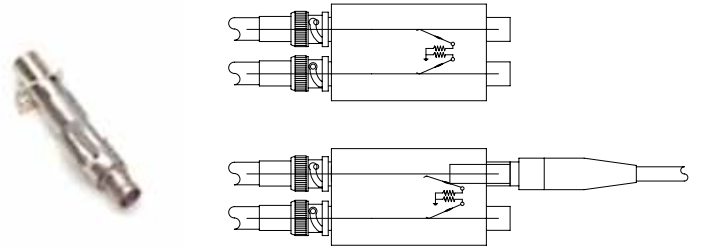

FULL-NORMAL / NON-TERMINATING (2WNHD)

Features a dual-body video jack. Signal flows through jack in un-patched state. When a patchcord is inserted, the signal path follows the patchcord.

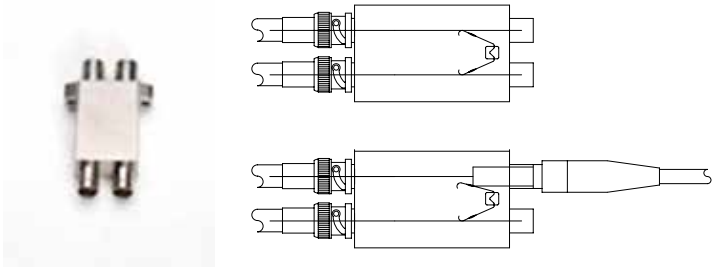

NON-NORMAL / NON-TERMINATING (1WNHD)

Features a single-body video jack. When a patchcord is inserted, the signal path follows the patchcord.

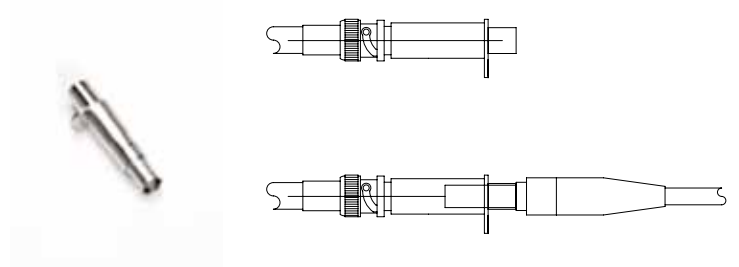

INSERTION LOSS / RETURN LOSS / SMITH CHART

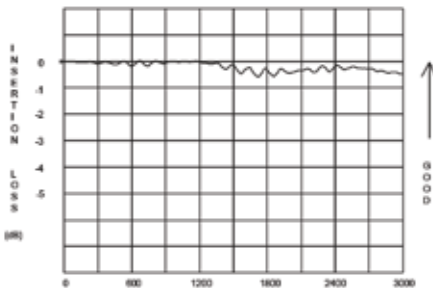

INSERTION LOSS DIAGRAM

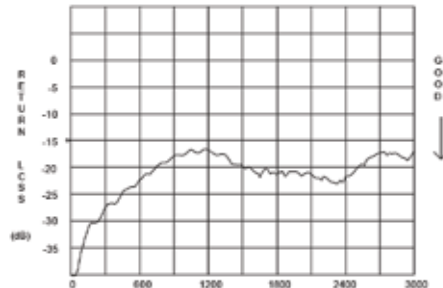

RETURN LOSS DIAGRAM

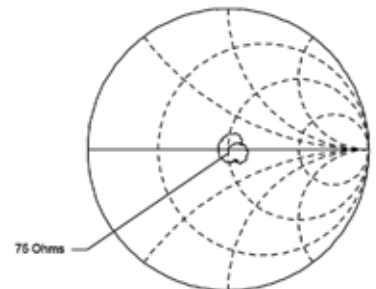

SMITH - Start: 30KHz / Stop:3.0GHz

HIGH-BANDWIDTH WECO PATCHBAY

CODES / PATCHCORDS

WECO ORDERING CODES

(B 48 T - 2 W N HD)

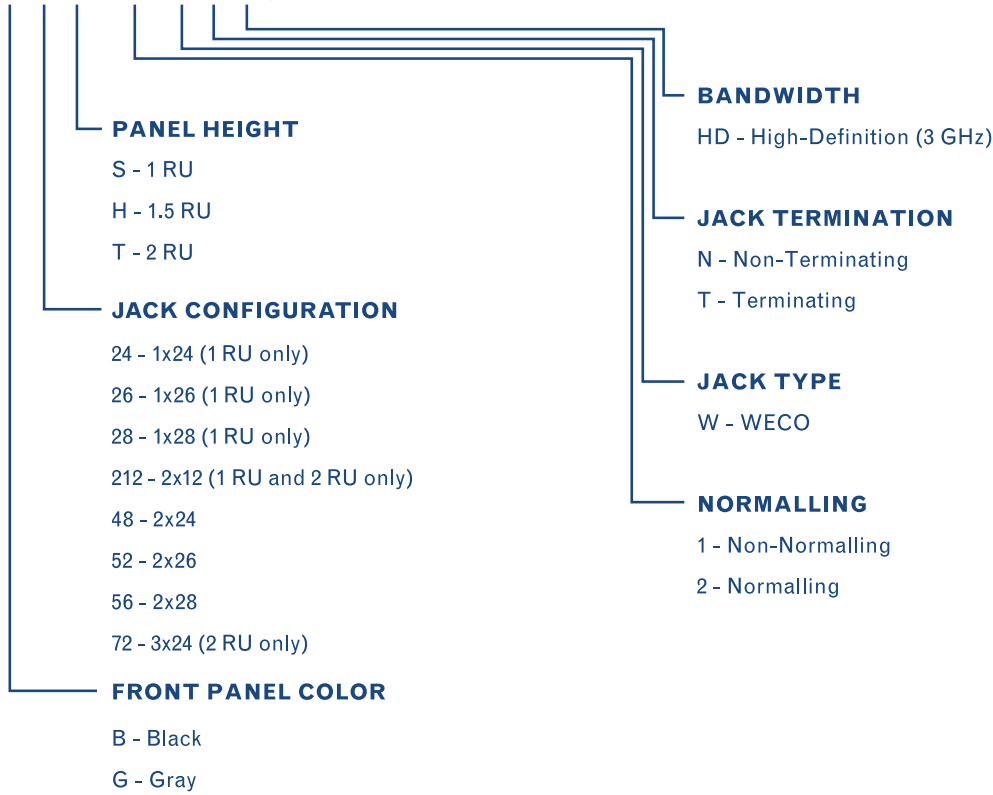

WECO PATCH CORDS

(VPC 24 00 -75)

LENGTH BY INCH (CM)	COLOR
24 (61)	00 - Black
36 (92)	02 - Red
48 (122)	04 - Yellow
60 (153)	05 - Green
72 (184)	06 - Blue
	07 - Purple



WECO LOOPING PLUGS

(LP 75 00)

COLOR
00 - Black
02 - Red
04 - Yellow
05 - Green
06 - Blue
08 - Gray



HIGH-BANDWIDTH

E-SERIES PATCHBAY

Our E-Series of WECO Video high-bandwidth patchbays are ideal for high-bandwidth applications such as HDTV, SDI, AES and high-resolution computer graphics, as well as for conventional analog applications such as monitor routing, primary routing, re-routing, router backup and video distribution. The E-series WECO has three additional features not found in the classic WECO video series: a flanged front panel, silk screened channel numbering on the front and rear of the panel for easy circuit identification, and front-load jacks.



FRONT



REAR

FRONT-LOADED JACKS

FRONT AND REAR OF PANEL FEATURES 1-24 SILK-SCREENED NUMBERING

HD/SDI, SD/SDI, 3GB/S AND 3-D APPLICATIONS

CONFORMS TO SMPTE 292M AND SMPTE 424M STANDARDS

FEATURES

- Spacious WECO format in 2 RU, 2x24 configuration
- Front panels feature 1-24 silk-screened numbering for easy circuit identification
- High-bandwidth performance for SD/SDI, HD/SDI, and 3 Gb/s applications
- Jacks conform to SMPTE 292M and SMPTE 424M
- True 75ohm impedance with low return loss
- Heavy-gauge aluminum panel features I-beam style construction for extra strength
- Durable, scratch-resistant powder-coat finish
- Extra wide designation strips
- Flanged panel

OPTIONS

Jacks maybe ordered in four different configurations:

- Dual body self-normaling, terminating (E-2WTHD)
- Dual body self-normaling, non-terminating (E-2WNHD)
- Dual body non-normaling, terminating (E-1WTHD)
- Dual body non-normaling, non-terminating (E-1WNHD)

HIGH-BANDWIDTH

E-SERIES PATCHBAY

PRODUCT NUMBERS

2x24, 2 RU, Black Dual Body, Normal / Terminating (EB48T-2WTHD)

2x24, 2 RU, Black Dual Body, Normal / Non-Terminating (EB48T-2WNHD)

2x24, 2 RU, Black Dual Body, Non-Normal / Terminating (EB48T-1WTHD)

2x24, 2 RU, Black Dual Body, Non-Normal / Non-Terminating (EB48T-1WNHD)

JACK SCHEMATICS

FULL-NORMAL / TERMINATING (2WTHD)

Features a dual-body video jack. Signal flows through jack in un-patched state. When a patchcord is inserted, the signal path follows the patchcord, and the opposite side of the jack is terminated with a 75 Ohm resistor.

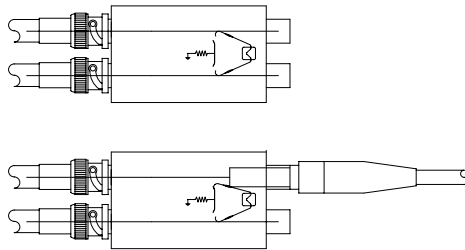

PATCHCORDS

E-SERIES PATCHCORDS

(VPC 24 00 -75)

LENGTH BY INCH (CM)

24 (61)

36 (92)

48 (122)

60 (153)

72 (184)

COLOR

00 - Black

02 - Red

04 - Yellow

05 - Green

06 - Blue

07 - Purple



E-SERIES LOOPING PLUGS

(LP 75 00)

COLOR

00 - Black

02 - Red

04 - Yellow

05 - Green

06 - Blue

08 - Gray



VIDEO

COMPONENT VIDEO

Bittree offers a full line of reliable component video patchbays, ideal for SD/SDI, HD/SDI, and other 3 Gb/s applications. Made from 3/16" solid aluminum and featuring the industry's finest fit-and-finish, our component video patchbays are available in both Mini-WECO and WECO formats. The Mini-WECO patchbays feature higher-density 1 x 6 up to 2 x 10 jack configurations, while the more spacious WECO format features 1 x 5 up to 2 x 10 jack configurations.

Both Mini-WECO and WECO are available in 1 or 2 RU sizes, and both come with an off-set "chevron" design to ensure correct patchcord insertion. Bittree component video patchbays are available in RGB and RGBHV models, and corresponding three-wire and five-wire patchcords are available. All component video jacks are SMPTE 292M and SMPTE 424M compliant.

Note on Mini-WECO vs. WECO formats: Most video patching systems in the U.S. use the WECO standard, developed by the Western Electric Company in the middle of the 20th century. WECO patchbays are usually considered easier to work with due to their more spacious jack configuration (1 x 5 configuration), while Mini-WECO patchbays are ideal for higher-density patching (1 x 6 configuration).



COMPONENT VIDEO

MINI-WECO COMPONENT

Our wide range of Mini-WECO Video Component patchbays are designed to meet all of your patching needs, from high bit-rate digital signals to base-band analog. Bittree Mini-WECO video patchbays are ideal for high-bandwidth applications such as HDTV, SDI, AES and high-resolution computer graphics, as well as in conventional analog applications such as monitor routing, primary routing, re-routing, router backup and video distribution.



FRONT



REAR

RGB AND RGBHV
COMPONENT MODELS
AVAILABLE

1 OR 2 RU SIZES,
WITH OFFSET
CHEVRON DESIGN

HD/SDI, SD/SDI, 3GB/S
AND 3-D APPLICATIONS

THREE-WIRE AND FIVE-
WIRE PATCHCORDS
AVAILABLE

FEATURES

- High-bandwidth performance for SD/SDI, HD/SDI, 3 Gb/s and 3-D applications
- Jacks conform to SMPTE 292M and SMPTE 424M
- True 75ohm impedance with low return loss
- The center RGB circuit is offset to ensure correct patchcord insertion.
- Panels made from 3/16 solid aluminum
- Staggered BNC rear interface
- Durable scratch-resistant power-coat finish
- Jacks are isolated from the panel
- Extra wide designation strips
- 3-circuit and 5-circuit patchcords available
- Circuit counts range from 1x6 up through 2x10
- Available in 1 or 2 rack unit (RU) sizes
- For higher density, some component video patchbays use a vertical jack configuration

OPTIONS

Jacks maybe ordered in four different configurations:

- Dual body self-normaling, terminating (2MWTHD)
- Dual body self-normaling, non-terminating (2MWNHD)
- Single body non-normaling, terminating (1MWTHD)
- Single body non-normaling, non-terminating (1MWNHD)

COMPONENT VIDEO

MINI-WECO COMPONENT

CODES / PATCHCORDS

MINI-WECO COMPONENT ORDERING CODES

(B RGB 20 T - 2 M N)

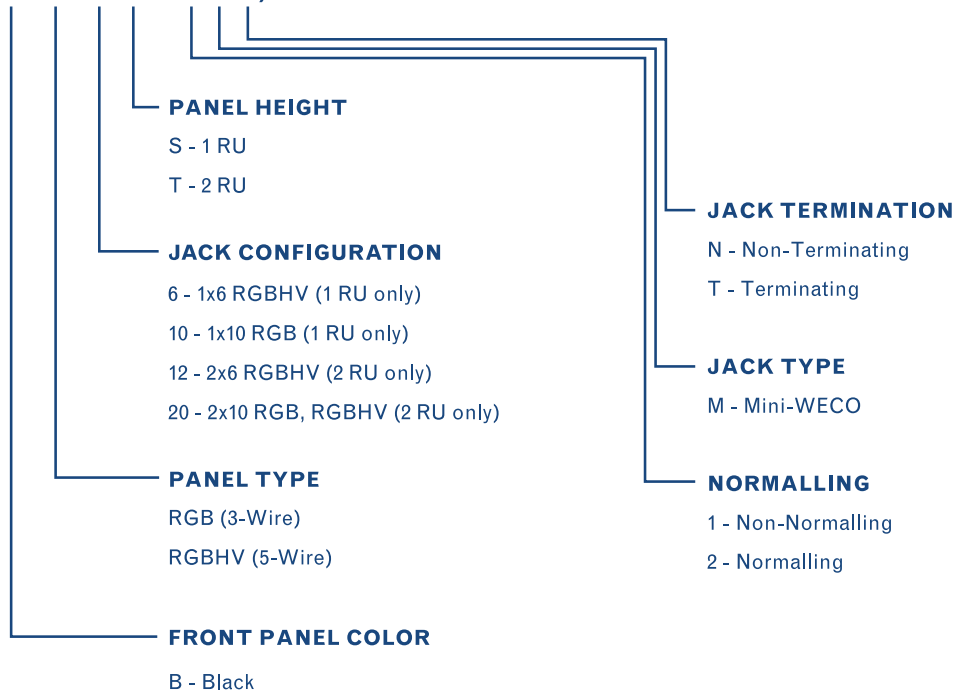

MINI-WECO COMPONENT PATCHCORDS

(CPCM HV 24 00 -75)

HV	LENGTH BY INCH (CM)	COLOR
HV - 5 wire	24 (61)	00 - Black
(RGBHV) only	36 (92)	
	48 (122)	
	60 (153)	
	72 (184)	



COMPONENT VIDEO

WECO COMPONENT

Our wide range of WECO Video Component patchbays are designed to meet all of your patching needs, from high bit-rate digital signals to base-band analog. Bittree WECO video patchbays are ideal for high-bandwidth applications such as HDTV, SDI, AES and high-resolution computer graphics, as well as in conventional analog applications such as monitor routing, primary routing, re-routing, router backup and video distribution.



FRONT



REAR

RGB AND RGBHV
COMPONENT MODELS
AVAILABLE

1 OR 2 RU SIZES,
WITH OFFSET
CHEVRON DESIGN

HD/SDI, SD/SDI, 3GB/S
AND 3-D APPLICATIONS

THREE-WIRE AND FIVE-
WIRE PATCHCORDS
AVAILABLE

FEATURES

- High-bandwidth performance for SD/SDI, HD/SDI, 3 Gb/s and 3-D applications
- Jacks conform to SMPTE 292M and SMPTE 424M
- True 75ohm impedance with low return loss
- The center RGB circuit is offset to ensure correct patchcord insertion.
- Panels made from 3/16" solid aluminum
- Staggered BNC rear interface
- Durable scratch-resistant power-coat finish
- Jacks are isolated from the panel
- Extra wide designation strips
- 3-circuit and 5-circuit patchcords available
- Circuit counts range from 1x6 up through 2x10
- Available in 1 or 2 rack unit (RU) sizes
- For higher density, some component video patchbays use a vertical jack configuration

OPTIONS

Jacks maybe ordered in four different configurations:

- Dual body self-normaling, terminating (2WTHD)
- Dual body self-normaling, non-terminating (2WNHD)
- Single body non-normaling, terminating (1WTHD)
- Single body non-normaling, non-terminating (1WNHD)

COMPONENT VIDEO

WECO COMPONENT

CODES / PATCHCORDS

WECO COMPONENT ORDERING CODES

(B RGB 20 T - 2 W N)

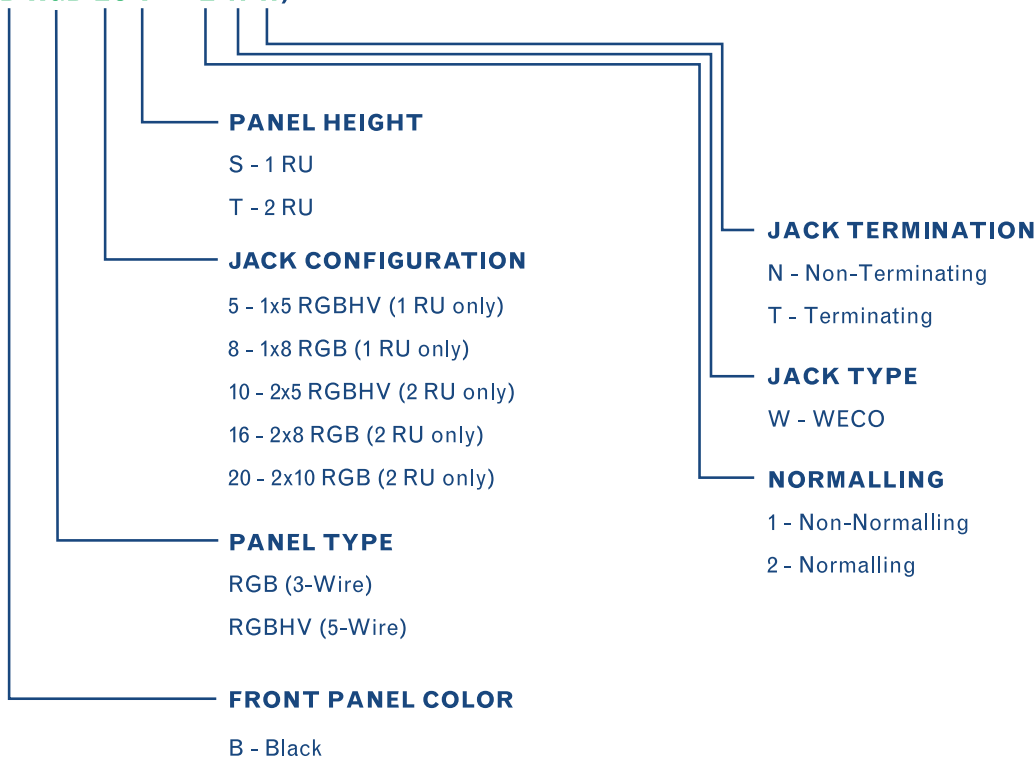

WECO COMPONENT PATCHCORDS

(CPC HV 24 00 -75)

HV	LENGTH BY INCH (CM)	COLOR
HV - 5 wire	24 (61)	00 - Black
(RGBHV) only	36 (92)	
	48 (122)	
	60 (153)	
	72 (184)	

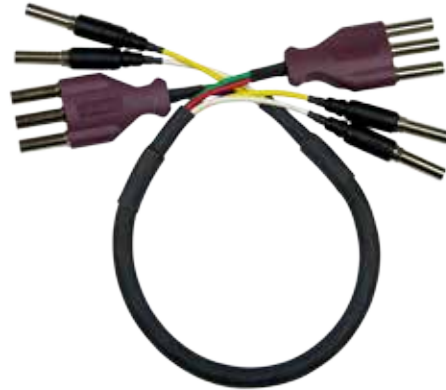

AUDIO

TT BANTAM

Bittree offers two formats of audio patchbays: Bantam (TT), described below, and Long Frame (1/4), described on page 38. Bantam patchbays are ideal for higher-density patching systems, due to their 2 x 48 jack configuration.

CHOOSING THE RIGHT AUDIO BANTAM PATCHBAY

969-A SERIES, FRONT PROGRAMMABLE

Our 969-A Series of Programmable patchbays allows you to change normaling and grounding for individual circuits simply by changing the shunt arrangement under the designation strips. Features convenient 1-48 left-to-right numbering on the patchbay front for easy identification of circuits. Available in 1.5 and 2 RU enclosed chassis.

969-S SERIES, FRONT PROGRAMMABLE

Includes the same features as the 969-A Series above, but also allows you to program switched grounds.

968 SERIES, INTERNALLY PROGRAMMABLE

Comes with the same programming capability as the 969 Series, but the programming is done internally.

968-S SERIES, INTERNALLY PROGRAMMABLE

Includes the same features as 968 Series above, but also allows you to program switched grounds.

961 SERIES, CLASSIC

Our original Bantam audio patchbay, featuring our most extensive selection of options available, including normals-out, over/over designations, stereo spacing, or single row patchbays.



TT BANTAM

969-A SERIES

Our 969-A Series features our innovative Programmable audio patchbays in a 2 x 48 1.5 or 2 RU size, and includes convenient 1-48 left-to-right numbering on the patchbay front for easy identification of circuits.

Programmable patchbays allow users to quickly and easily change the normals and grounding of individual circuits. Normals can be changed to full-normal, half-normal or non-normal. Grounding can be changed to bussed, isolated or looped (for switched grounds, consider the 969-S Series).

Because it's programmable, the 969 Series can serve as the foundation for virtually any new, reconfigured or legacy installation. The end result is a patchbay that allows integrators and installers to quickly re-configure patching systems, accommodate customer change-orders, and speed service-calls.



FRONT W/ TOP DESIGNATION REMOVED

FRONT PROGRAMMABLE
AUDIO BANTAM (TT)
PATCHBAY

NORMALS AND
GROUNDS CAN BE
EASILY RE-PROGRAMMED
BY THE END USER

HIGH-DENSITY 2X48 JACK
CONFIGURATION; 1.5 OR
2 RU SIZE

REAR INTERFACE
OPTIONS INCLUDE
E-3, E-90, ID (PUNCH-
DOWN) AND D25

1-48 NUMBERING ON
FRONT PANEL FOR EASY
CIRCUIT IDENTIFICATION



REAR

969-A SERIES

PROGRAMMING INSTRUCTIONS

HOW TO IDENTIFY A PROGRAMMABLE PATCHBAY

969-A Series programmable patchbays can be identified by the word Programmable and Model 969-A on the far right edge of the patchbay.



HOW TO CHANGE THE PROGRAMMING FOR A CIRCUIT

- 1: Remove the two designation strips.
- 2: Find your desired configuration in the diagram.
- 3: Arrange the programming shunts to match the appropriate diagram. Note: Each circuit can be programmed independently.
- 4: Ample shunts are provided with every programmable patchbay. Red shunts are placed horizontally and are used for normaling options. White shunts (shown as light gray above) are placed vertically and are used for grounding options.
- 5: The circuits are numbered 1-48 and correspond to vertical jack pairs reading left to right, with the even-numbered circuits on the top row, and the odd-numbered circuits on the bottom row.
- 6: Replace the designation strips.

These programming instructions can be used for both the new 969-A Series and the original 969 Series.

SHUNTS SCHEMATICS

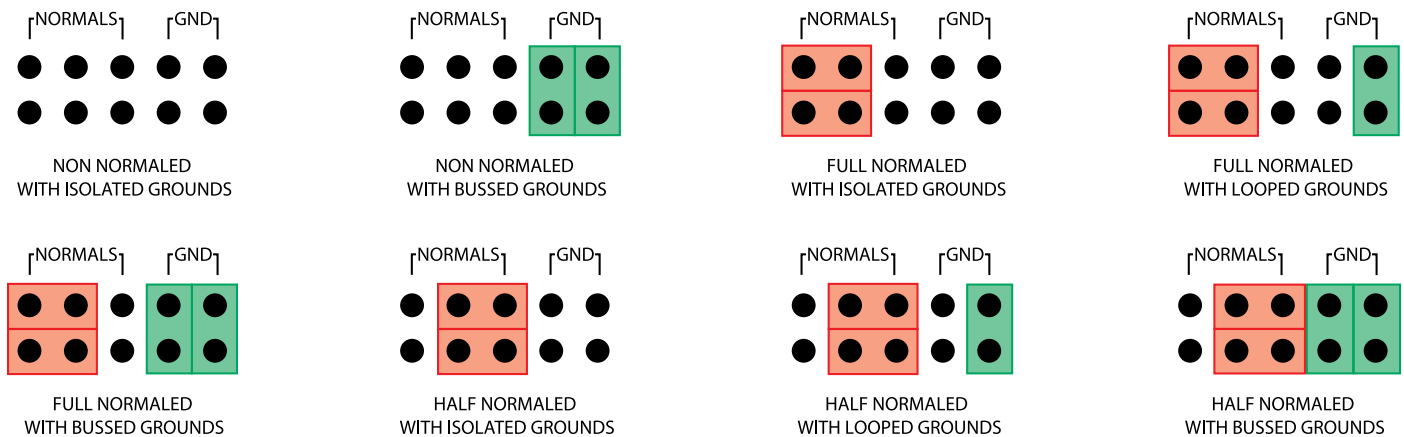

969-A SERIES

CODES / PATCHCORDS

969-A ORDERING CODES

(B 96 D C - F N A I T / E 3 M 2 O U 1 2 B)

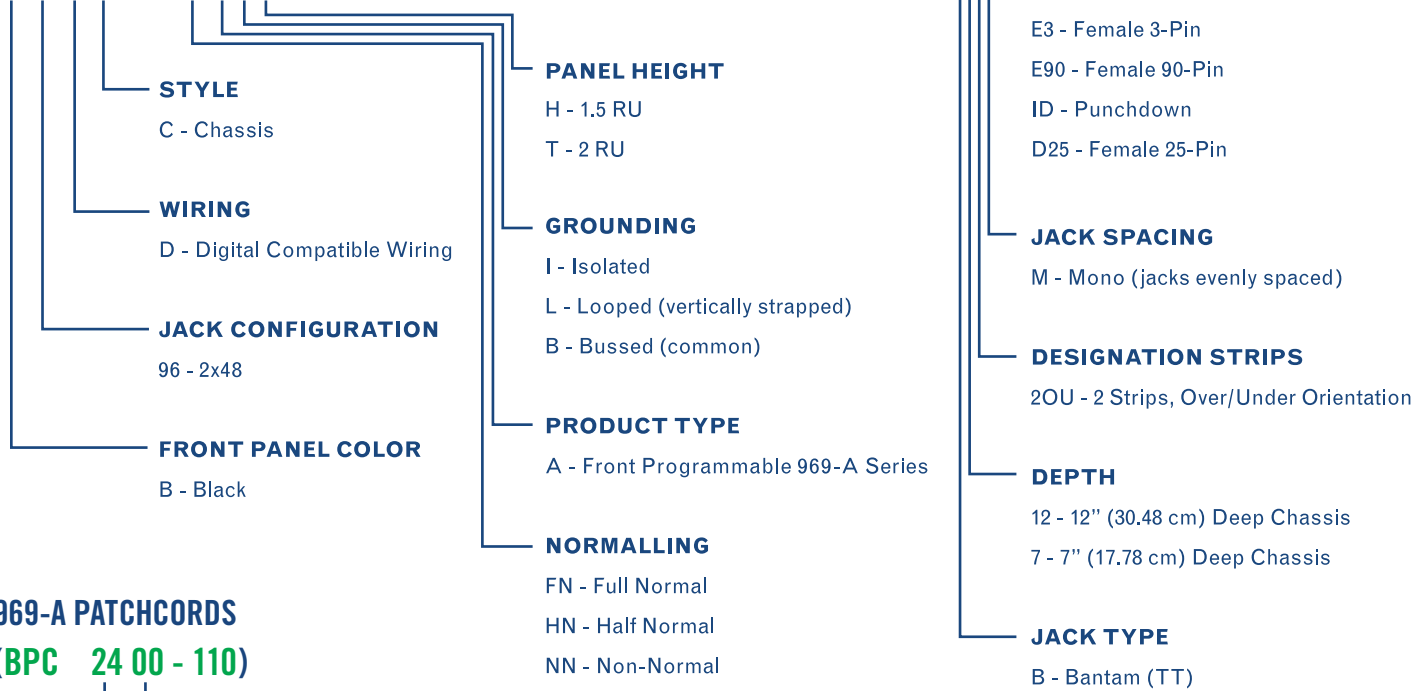

969-A PATCHCORDS

(BPC 24 00 - 110)

LENGTH BY INCH (CM)	COLOR
24 (61)	00 - Black
36 (92)	02 - Red
48 (122)	04 - Yellow
60 (153)	05 - Green
72 (184)	06 - Blue
	07 - Purple



JACK SCHEMATICS (EXAMPLES)

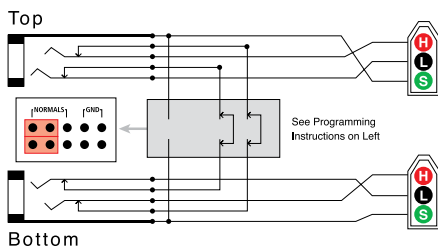

FULL NORMALED PROGRAMMABLE ISOLATED GROUNDS

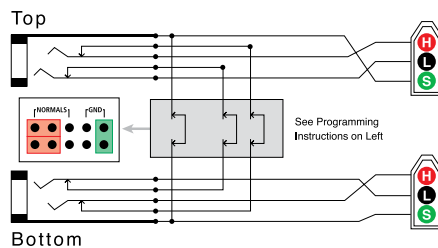

FULL NORMALED PROGRAMMABLE LOOPED GROUNDS

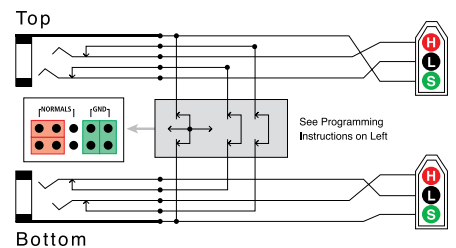

FULL NORMALED PROGRAMMABLE BUSSED GROUNDS

TT BANTAM

969-S SERIES

Our 969-S Series features our innovative Programmable audio patchbays in a 2 x 48 1.5 or 2 RU size, with the added capability of programming switched grounds. Switched grounds can help eliminate hard-to-find ground loops, and because it provides a more stable signal grounding structure, it's ideal for systems with audio signals coming from numerous locations.

The 969-S programmable patchbay allow users to quickly and easily change the normals and grounding of individual circuits. Normals can be changed to full-normal, half-normal or non-normal. Grounding can be changed to switched or bussed. Because it's programmable, the 969-S Series can serve as the foundation for virtually any new, reconfigured or legacy installation. The end result is a patchbay that allows integrators and installers to quickly re-configure patching systems, accommodate customer change-orders, and speed service-calls.



FRONT



REAR

FRONT PROGRAMMABLE
AUDIO BANTAM (TT)
PATCHBAY

NORMALS AND
GROUNDS CAN BE
EASILY RE-PROGRAMMED
BY THE END USER

ALLOWS SWITCHED
GROUNDS FOR A
MORE STABLE
SIGNAL STRUCTURE

HIGH-DENSITY 2X48 JACK
CONFIGURATION; 1.5 OR
2 RU SIZE

REAR INTERFACE
OPTIONS INCLUDE
E-3, E-90, ID (PUNCH-
DOWN) AND D25

969-S SERIES

PROGRAMMING INSTRUCTIONS

HOW TO IDENTIFY A PROGRAMMABLE PATCHBAY

969-S Series programmable patchbays can be identified by the word Programmable and Model 969S on the far right edge of the patchbay.



HOW TO CHANGE THE PROGRAMMING FOR A CIRCUIT

- 1: Remove the two designation strips.
- 2: Find your desired configuration in the diagram.
- 3: Arrange the programming shunts to match the appropriate diagram. Note: Each circuit can be programmed independently.
- 4: Ample shunts are provided with every programmable patchbay. Red shunts are placed horizontally and are used for normalizing options. White shunts are placed vertically and are used for grounding options.
- 5: The circuits are numbered 1-48 and correspond to vertical jack pairs reading left to right, with the even-numbered circuits on the top row, and the odd-numbered circuits on the bottom row.
- 6: For the internal programming, unscrew the screws along the top edges and take off the patchbay dust cover. Locate the Internal PCB Boards inside, which are right behind the back of the jacks (for a better view, turn the rear of the patchbay toward you). There are eight PCB Boards; each one holds six circuits.
- 7: Depending on the Normal/Grounding configuration you want for each circuit, choose Internal Programming
- 8: Replace the dust cover and designation strips.

SHUNT SCHEMATICS

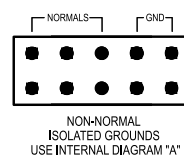
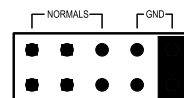
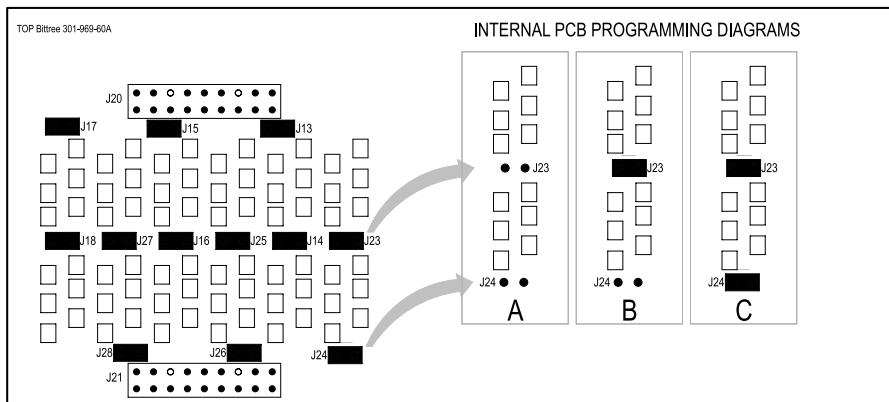
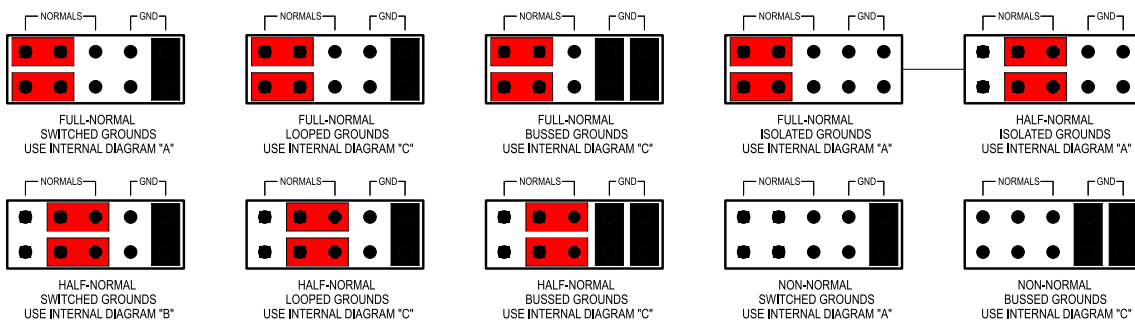

969-S SERIES

CODES / PATCHCORDS

969-S ORDERING CODES

(B 96 D C - FN S S T /E3 M 2OU 12 B)

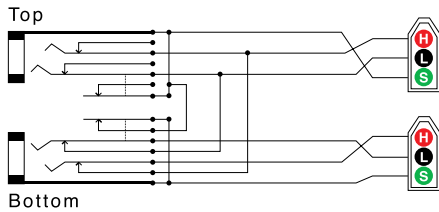
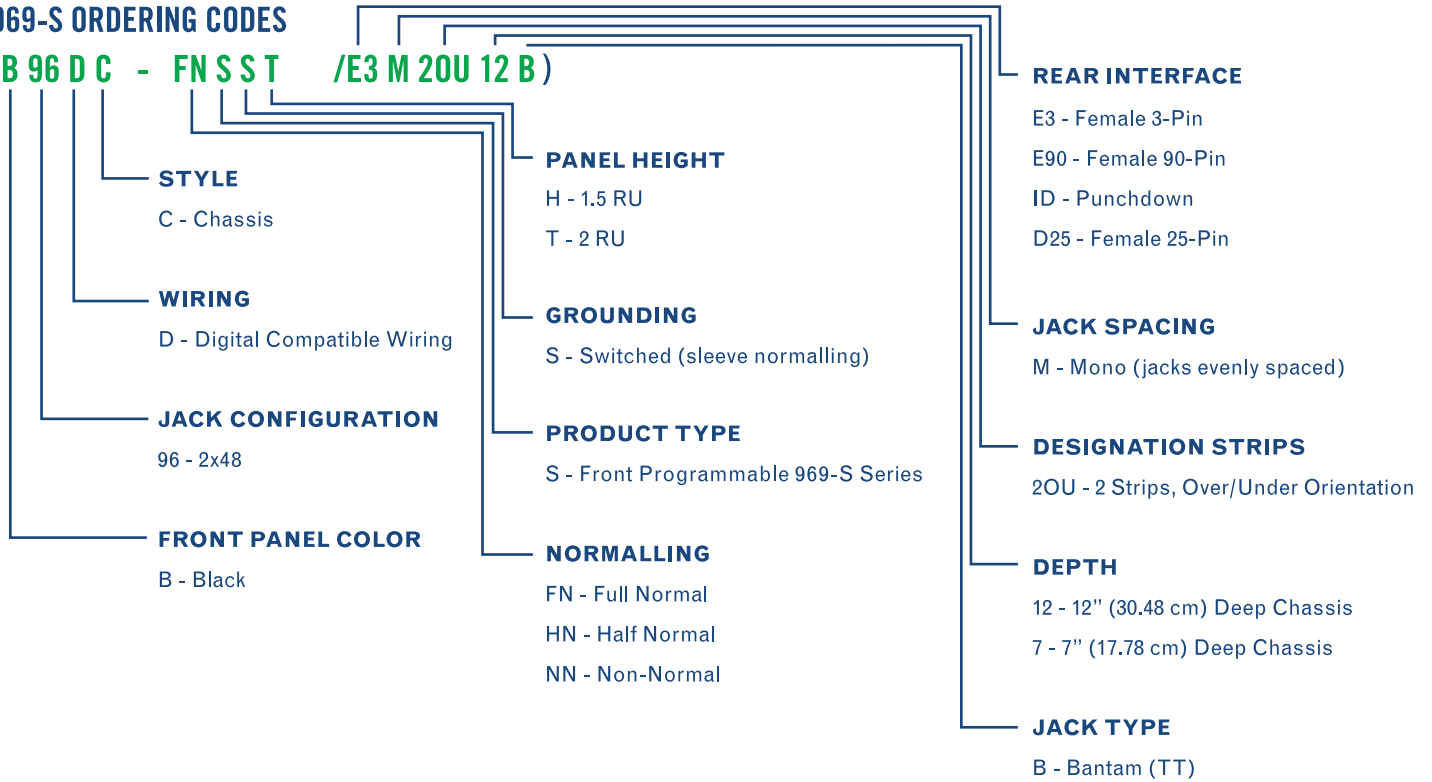

FULL NORMALED SWITCHED GROUNDS

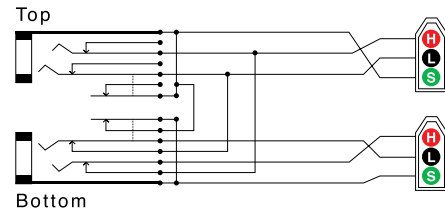

HALF NORMALED SWITCHED GROUNDS

TT BANTAM

968 SERIES

Our 968 Series features our innovative Programmable audio patchbays in a 2 x 48 1 RU, 1.5RU, or 2RU size, making them ideal for mobile production and other applications in tight quarters. With recent developments to our product line, Bittree's 968 series is now available in 1.5RU and 2RU versions as well.

Programmable patchbays allow users to quickly and easily change the normals and grounding of individual circuits. Normals can be changed to full-normal, half-normal or non-normal. Grounding can be changed to bussed, isolated or looped (for switched grounds, consider the 968-S Series). Because it's programmable, the 968 Series can serve as the foundation for virtually any new, reconfigured or legacy installation. The end result is a patchbay that allows integrators and installers to quickly re-configure patching systems, accommodate customer change-orders, and speed service-calls.



FRONT



REAR

FRONT PROGRAMMABLE
AUDIO BANTAM (TT)
PATCHBAY

NORMALS AND
GROUNDS CAN BE
EASILY RE-PROGRAMMED
BY THE END USER

HIGH-DENSITY 2X48 JACK
CONFIGURATION; 1.5 OR
2 RU SIZE

REAR INTERFACE
OPTIONS INCLUDE
E-3, E-90, AND D25

SMALL SIZE IS
IDEAL FOR MOBILE
PRODUCTION AND
OTHER APPLICATIONS
IN TIGHT QUARTERS

968 SERIES

PROGRAMMING INSTRUCTIONS

HOW TO IDENTIFY A PROGRAMMABLE PATCHBAY

968 Series programmable patchbays can only be identified by removing the top dust cover and looking for the presence of red and white programming shunts inside.



HOW TO CHANGE THE PROGRAMMING FOR A CIRCUIT

- 1: Remove the top dust cover to expose the programming shunts on the rear of the circuit board.
- 2: Find your desired configuration in the diagram.
- 3: Arrange the programming shunts to match the appropriate diagram. Note: Each circuit can be programmed independently.
- 4: Ample shunts are provided with every programmable patchbay. All shunts should be placed vertically. Red shunts are used for grounding options. White shunts are used for normalizing options.
- 5: Replace the dust cover.

SHUNT SCHEMATICS (REV B VERSION)

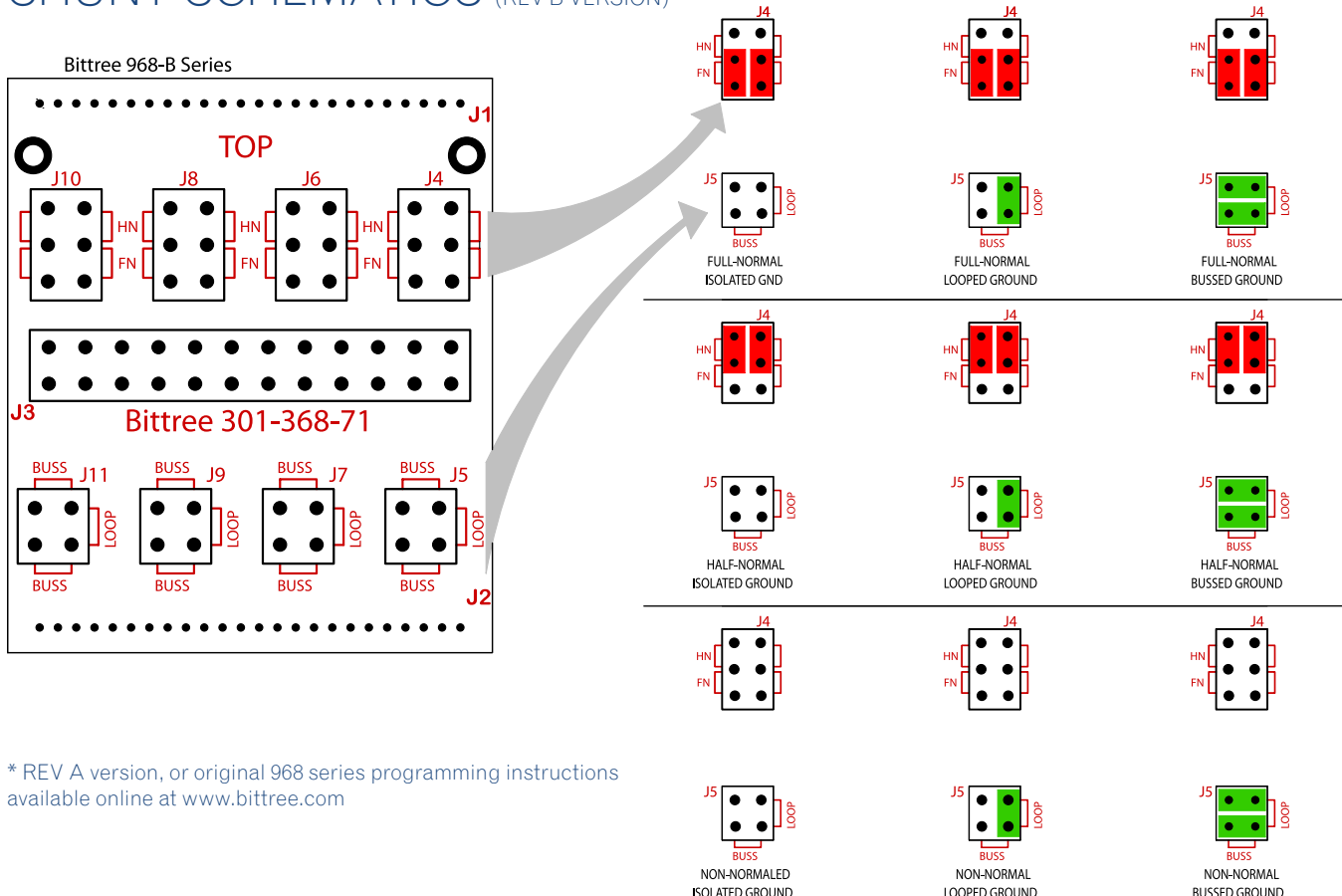

* REV A version, or original 968 series programming instructions available online at www.bittree.com

CODES / PATCHCORDS

968 ORDERING CODES

(B 96 D C - FN I I S /E3 M 20U 12 B)

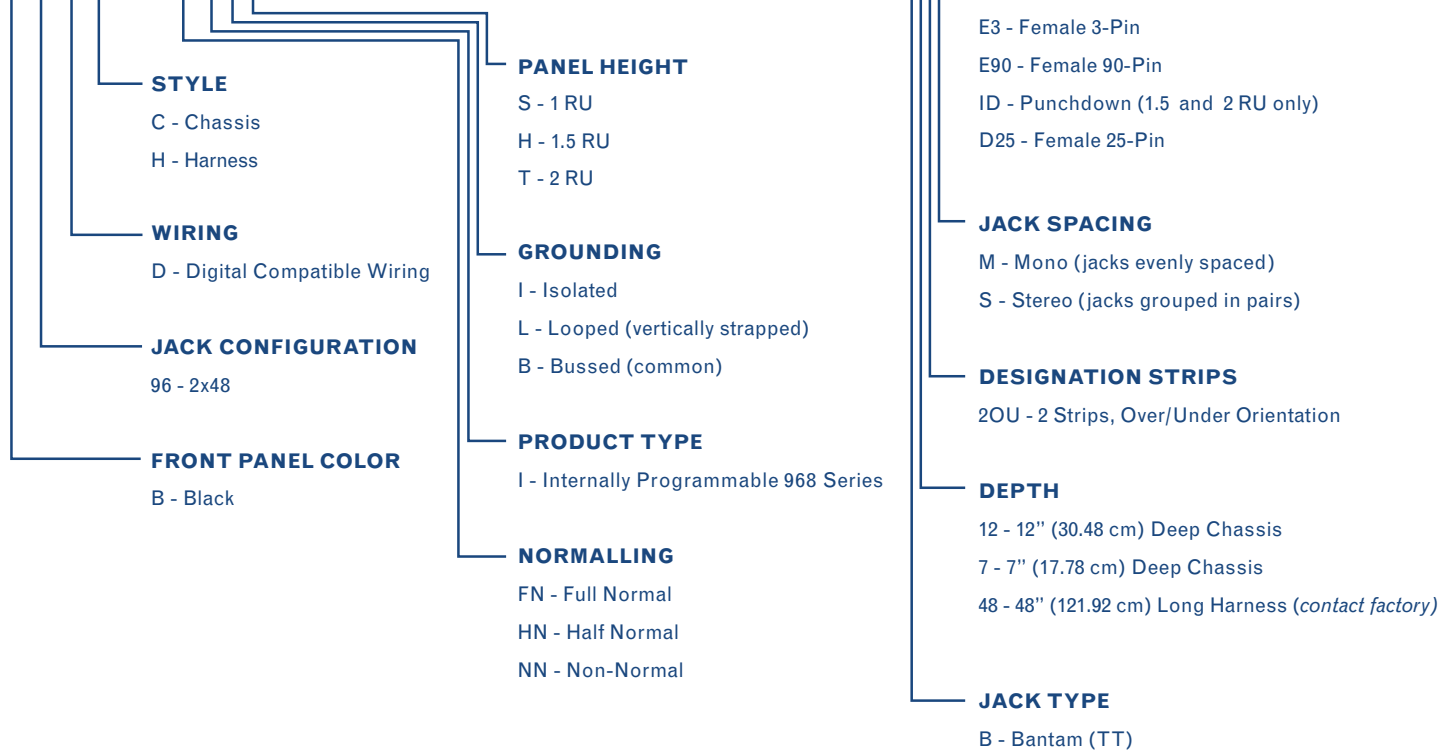

JACK SCHEMATICS (EXAMPLES)

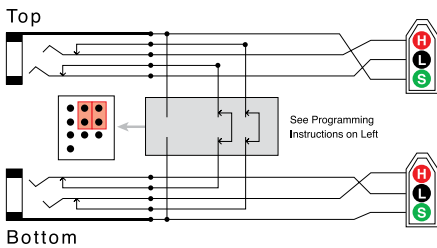

FULL NORMALED PROGRAMMABLE ISOLATED GROUNDS

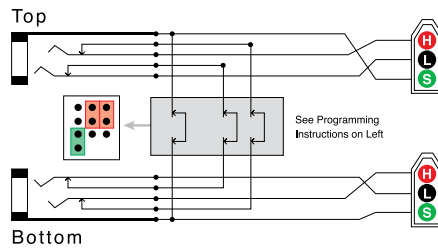

FULL NORMALED PROGRAMMABLE LOOPED GROUNDS

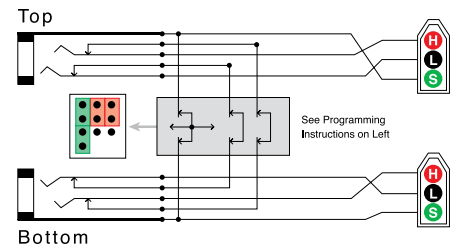

FULL NORMALED PROGRAMMABLE BUSSED GROUNDS

* Example based on original 968 series

TT BANTAM

968-S SERIES

Our 968-S Series features our innovative Programmable audio patchbays in a 2 x 48 1 RU size, making them ideal for mobile production and other applications in tight quarters. In addition, the 968-S lets you program switched grounds. Switched grounds help eliminate hard-to-find ground loops. Because it provides a more stable signal grounding structure, it's ideal for systems with audio signals coming from numerous locations.

Programmable patchbays allow users to quickly and easily change the normals and grounding of individual circuits. Normals can be changed to full-normal, half-normal or non-normal. Grounding can be changed to switched or bussed. Because it's programmable, the 968-S Series can serve as the foundation for virtually any new, reconfigured or legacy installation. The end result is a patchbay that allows integrators and installers to quickly re-configure patching systems, accommodate customer change-orders, and speed service-calls.



FRONT



REAR

NORMALS AND
GROUNDS CAN BE
EASILY RE-PROGRAMMED
BY THE END USER

ALLOWS SWITCHED
GROUNDS FOR A
MORE STABLE
SIGNAL STRUCTURE

HIGH-DENSITY 2X48 JACK
CONFIGURATION; 1.5 OR
2 RU SIZE

REAR INTERFACE
OPTIONS INCLUDE
E-3, E-90, ID (PUNCH-
DOWN) AND D25

SMALL SIZE IS
IDEAL FOR MOBILE
PRODUCTION AND
OTHER APPLICATIONS
IN TIGHT QUARTERS

968-S SERIES

PROGRAMMING INSTRUCTIONS

HOW TO IDENTIFY A PROGRAMMABLE PATCHBAY

968-S Series programmable patchbays can only be identified by removing the top dust cover and looking for the presence of red and white programming shunts inside.



HOW TO CHANGE THE PROGRAMMING FOR A CIRCUIT

- 1: Remove the top dust cover to expose the programming shunts.
- 2: Find your desired configuration in the diagram.
- 3: Arrange the programming shunts to match the appropriate diagram. Note: Each circuit can be programmed independently.
- 4: Ample shunts are provided with every programmable patchbay. All shunts should be placed vertically. Red shunts are used for grounding options. White shunts are used for normalizing options.
- 5: Replace the dust cover.

SHUNT SCHEMATICS

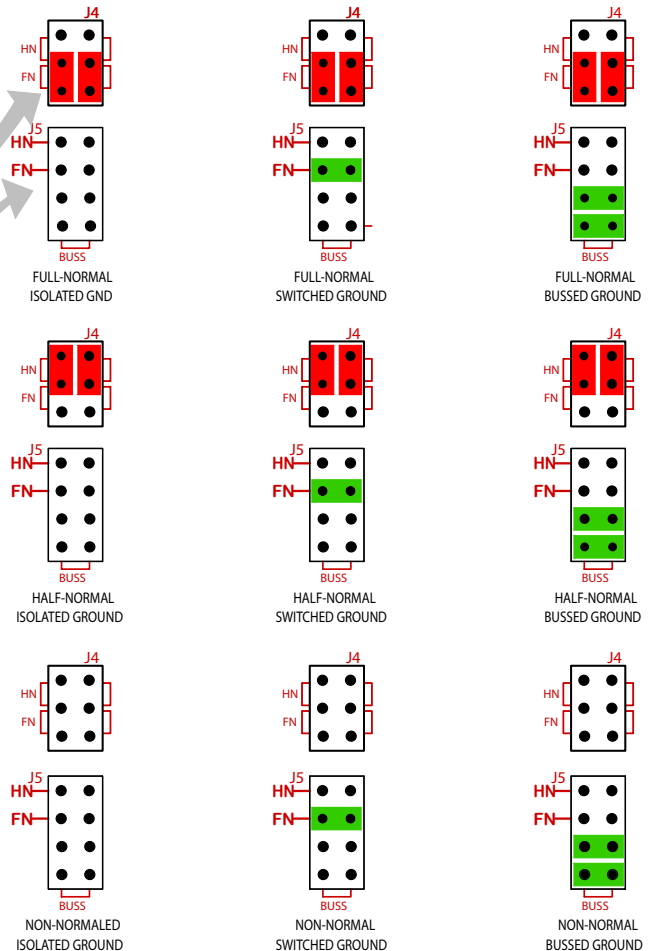
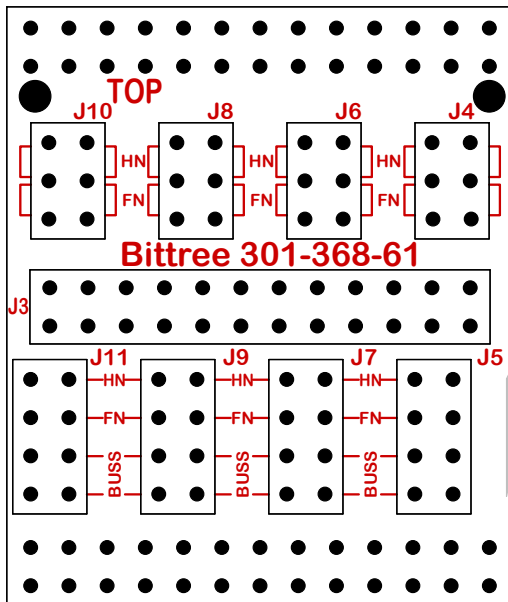

968-S SERIES

CODES / PATCHCORDS

968-S ORDERING CODES

(B 96 D C - FN R S S /E3 M 2OU 12 B)

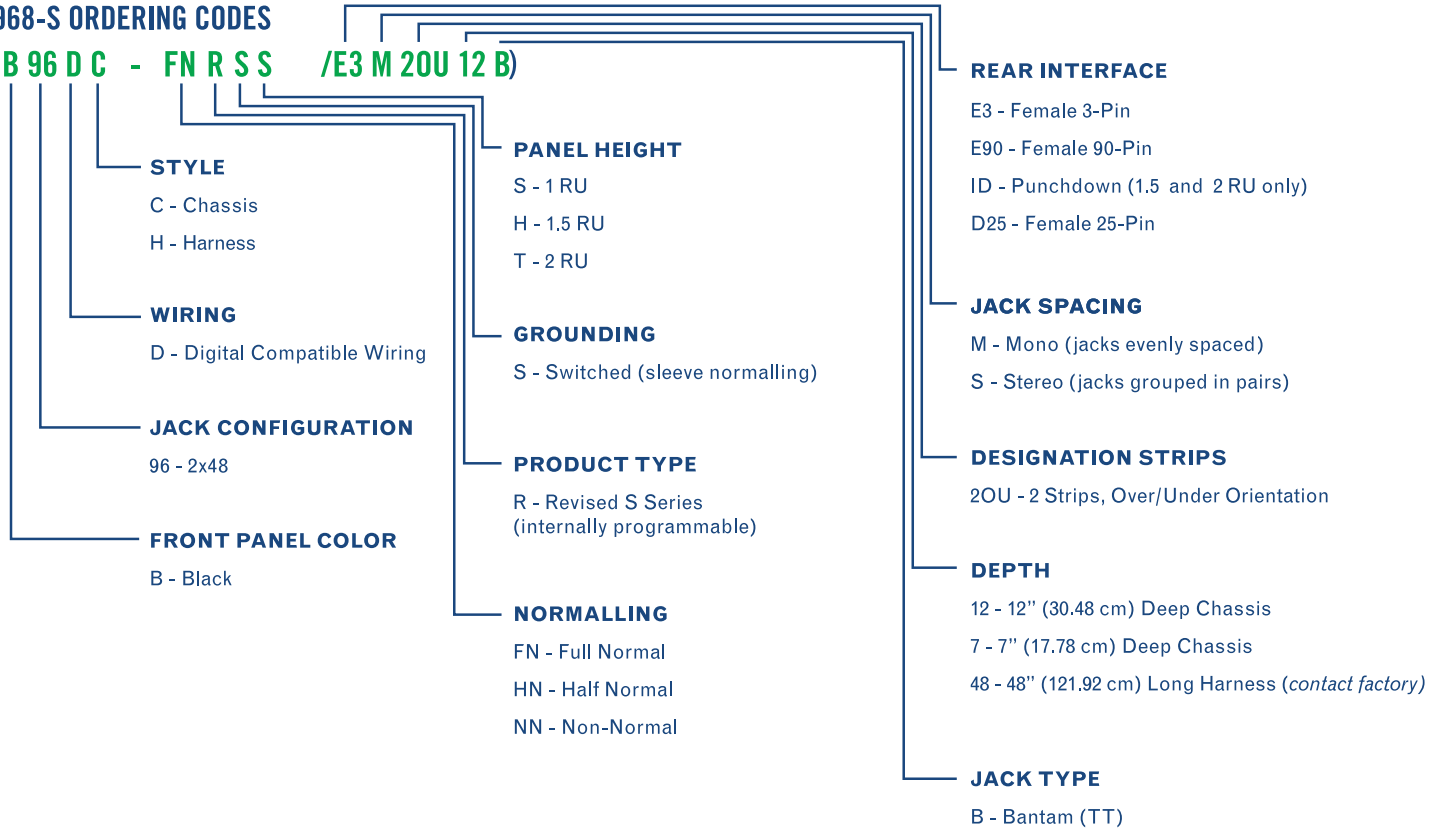

JACK SCHEMATICS (EXAMPLES)

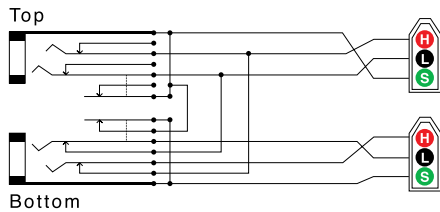

HALF NORMALED SWITCHED GROUNDS

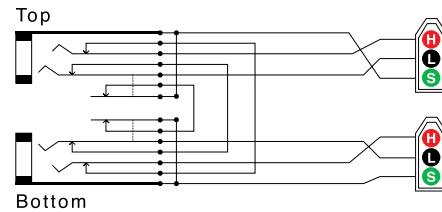

FULL NORMALED SWITCHED GROUNDS

* Example based on original 968-S series

TT BANTAM

961 SERIES

Our 961 Series features our classic, non-programmable audio patchbays. With a jack configuration of 2 x 48, the 961 Series comes with the most options of any audio patchbay, including rear interface, normaling, grounding, jack spacing, panel color, chassis depth and rack-unit height.

All Bittree audio patchbays bring you enhanced studio versatility and instant signal re-routing, and are perfect for master control and central switching I/O, audio console I/O, recording device I/O, and audio routing switcher bypass and input rerouting. Our audio patchbays are built to AES/EBU specifications, and are internally wired with low-capacitance, shielded, 110-ohm twisted pairs. The low-capacitance characteristics make them ideal for both digital as well as analog applications.



FRONT

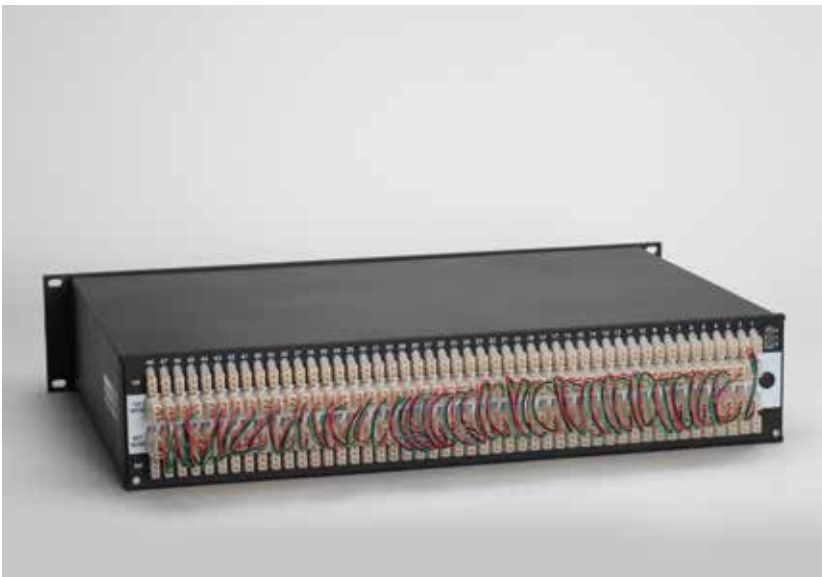

NORMALS-OUT



1x48 MONITOR ROW

961 SERIES

CODES / PATCHCORDS

968 ORDERING CODES

(B 96 D C - FN L I T /E3 S 200 12 B)

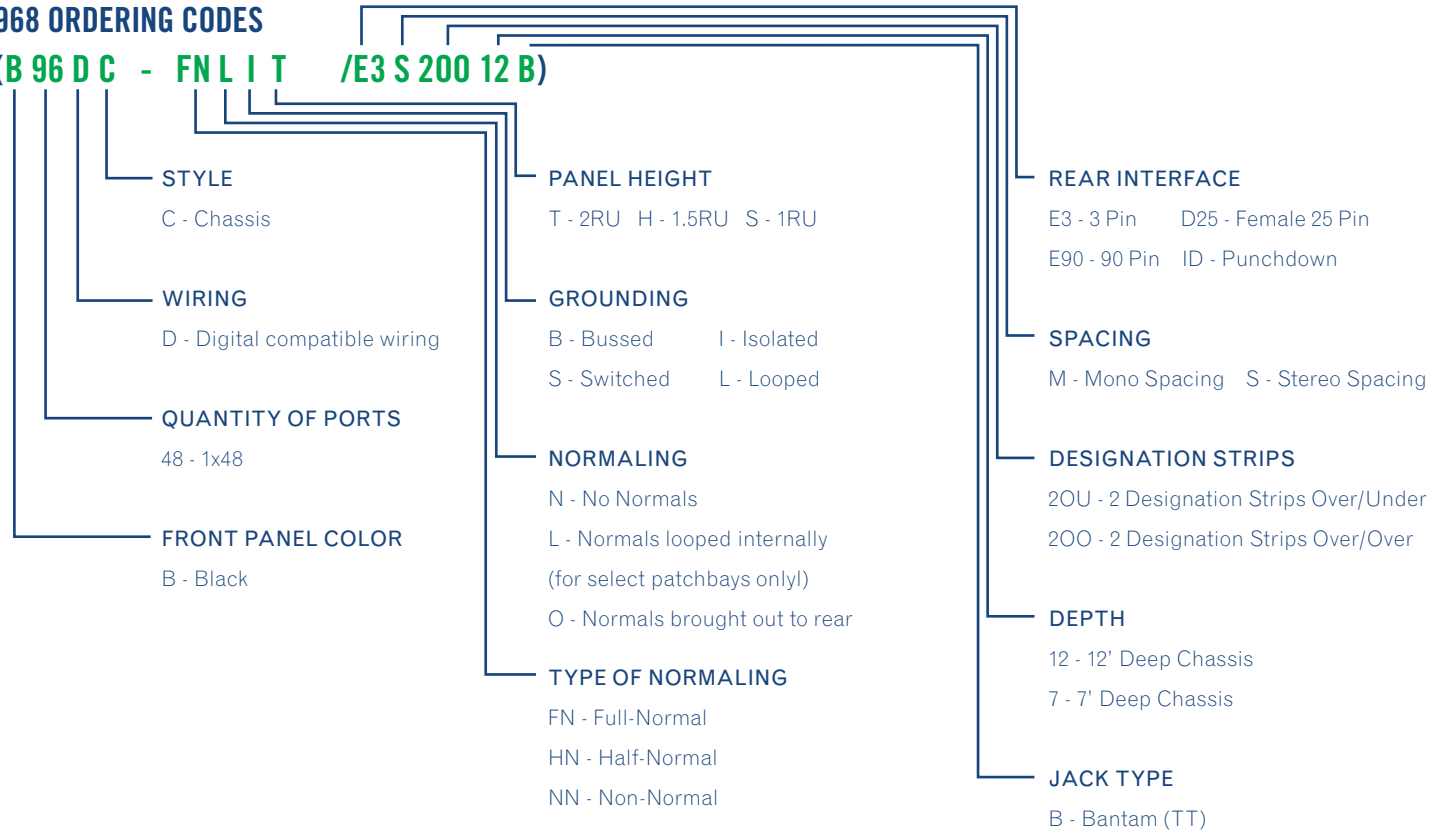

JACK SCHEMATICS (EXAMPLES)

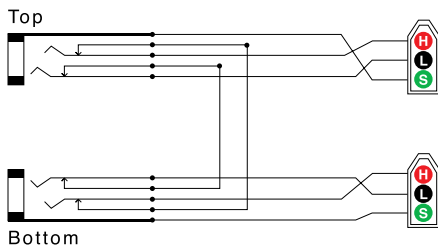

FULL NORMALED
ISOLATED GROUNDS

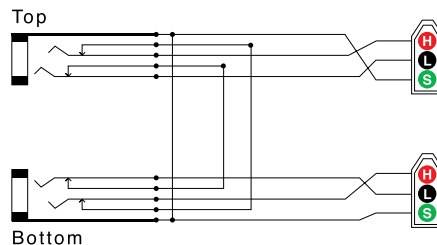

FULL NORMALED
LOOPED GROUNDS

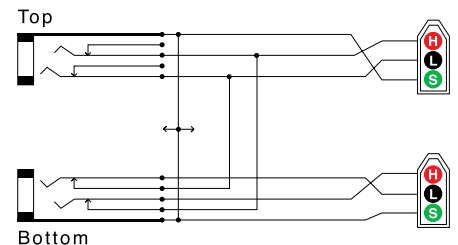

FULL NORMALED
BUSSED GROUNDS

AUDIO

AUDIO 1/4" LONGFRAME

Bittree offers two formats of audio patchbays: Long Frame (1/4"), described below, and Bantam (TT), described on page 33. Long-Frame patchbays are often considered easier to work with due to their spacious 2 x 24 jack configuration.

CHOOSING THE RIGHT LONG-FRAME PATCHBAY

489 SERIES, FRONT PROGRAMMABLE

Our Programmable patchbay allows you to change normaling and grounding for individual circuits simply by changing the shunt arrangement under the designation strips.

Available in 1.5 and 2 RU enclosed chassis.

489-S SERIES, FRONT PROGRAMMABLE

Includes the same features as the 489 Series above, but also allows you to program switched grounds in addition to bussed, isolated and looped grounds as with the original 489 series.

488 SERIES, INTERNALLY PROGRAMMABLE

Comes with the same programming capability as the 489 Series, but the programming is done internally so it can fit into a 1 RU enclosed chassis.

481 SERIES, CLASSIC

Our original Bantam audio patchbay, featuring our most extensive selection of options available, including normals out, grounding, and other internal hard-wiring options, rear panel configurations, stereo/mono spacing, panel color, rack-unit height, and harness configurations. Non-programmable.

521 SERIES, CLASSIC, 2 x 26

Includes the same extensive selections of available options as the 481 Series above, but in a slightly more condensed 2 x 26 format.

1/4" LONGFRAME

489 SERIES

Our 489 Series features our innovative Programmable audio patchbays in a 2 x 24 jack configuration, with panel height options of 1.5 or 2 RU size. Programmable patchbays allow users to quickly and easily change the normals and grounding of individual circuits. Normals can be changed to full-normal, half-normal or non-normal. Grounding can be changed to bussed, isolated or looped (for switched grounds, consider the 489-S Series).

Because it's programmable, the 489 Series can serve as the foundation for virtually any new, reconfigured or legacy installation. The end result is a patchbay that allows integrators and installers to quickly re-configure patching systems, accommodate customer change-orders, and speed service-calls.

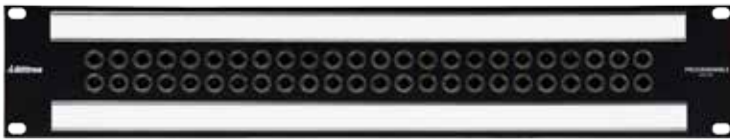

FRONT



REAR



NO STRIPS

FRONT PROGRAMMABLE
AUDIO LONG-FRAME 1/4"
PATCHBAY

NORMALS AND
GROUNDS CAN BE
EASILY REPROGRAMMED
BY THE END USER

SPACIOUS 2x24 JACK
CONFIGURATION; 1.5 OR
2RU SIZE

REAR INTERFACE OPTIONS
INCLUDE E-3, E-90, D-25,
AND ID (PUNCHDOWN)

1/4" LONGFRAME 489 SERIES

PROGRAMMING INSTRUCTIONS

HOW TO IDENTIFY A PROGRAMMABLE PATCHBAY

489 Series programmable patchbays can be identified by the Programmable Icon in the upper left corner of the patchbay.



HOW TO CHANGE THE PROGRAMMING FOR A CIRCUIT

- 1: Remove the top designation strip, as shown in the photo on the right.
- 2: Find your desired configuration in the diagram.
- 3: Arrange the programming shunts to match the appropriate diagram. Note: Each circuit can be programmed independently.
- 4: Ample shunts are provided with every programmable patchbay. All shunts should be placed vertically. Red shunts are used for grounding options. White shunts are used for normalizing options.
- 5: The circuits are numbered 1-24 and correspond to vertical jack pairs reading left to right.
- 6: Replace the designation strip.

SHUNT SCHEMATICS

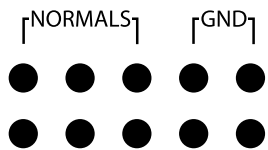

NON NORMALED
WITH ISOLATED GROUNDS

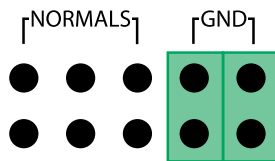

NON NORMALED
WITH BUSSED GROUNDS

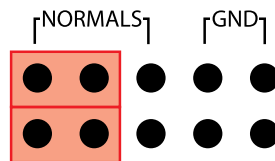

FULL NORMALED
WITH ISOLATED GROUNDS

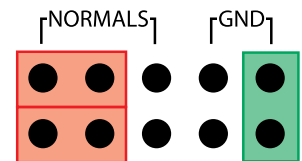

FULL NORMALED
WITH LOOPED GROUNDS

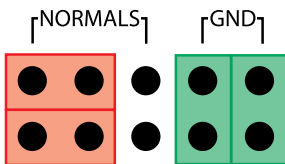

FULL NORMALED
WITH BUSSED GROUNDS

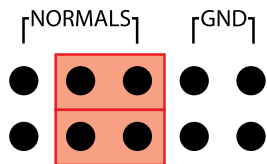

HALF NORMALED
WITH ISOLATED GROUNDS

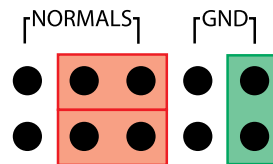

HALF NORMALED
WITH LOOPED GROUNDS

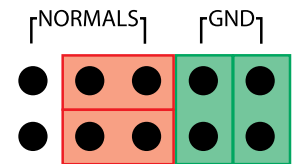

HALF NORMALED
WITH BUSSED GROUNDS

1/4" LONGFRAME 489 SERIES

CODES / PATCHCORDS

489-A ORDERING CODES

(B 48 DC - FN P BT /E3 M 2OU 12 L)

STYLE

C - Chassis

WIRING

D - Digital Compatible Wiring

JACK CONFIGURATION

48 - 2x24

FRONT PANEL COLOR

B - Black

PANEL HEIGHT

H - 1.5 RU

T - 2 RU

GROUNDING

I - Isolated

L - Looped (vertically strapped)

B - Bussed (common)

PRODUCT TYPE

P - Front Programmable 489-A Series

NORMALLING

FN - Full Normal

HN - Half Normal

NN - Non-Normal

REAR INTERFACE

E3 - Female 3-Pin

E90 - Female 90-Pin

ID - Punchdown

D25 - Female 25-Pin (*contact factory*)

JACK SPACING

M - Mono (jacks evenly spaced)

DESIGNATION STRIPS

2OU - 2 Strips, Over/Under Orientation

DEPTH

12 - 12" (30.48 cm) Deep Chassis

7 - 7" (17.78 cm) Deep Chassis

JACK TYPE

L - Long-Frame (1/4")

AUDIO LONGFRAME PATCHCORDS

(LPC 24 00 - 110)

LENGTH BY INCH (CM)

24 (61)

36 (92)

48 (122)

60 (153)

72 (184)

COLOR

00 - Black

02 - Red

04 - Yellow

05 - Green

06 - Blue

07 - Purple



JACK SCHEMATICS (EXAMPLES)

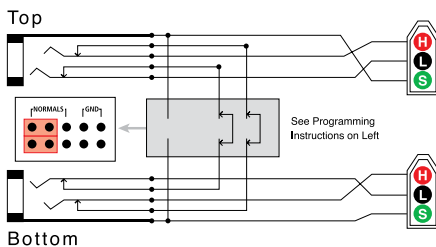

FULL NORMALED PROGRAMMABLE
ISOLATED GROUNDS

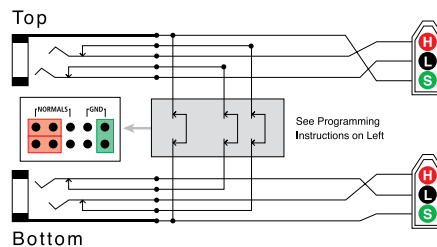

FULL NORMALED PROGRAMMABLE
BUSSED GROUNDS

1/4" LONGFRAME

489-S SERIES

Our 489-S Series features our innovative Programmable audio patchbays in a 2 x 24 jack configuration with a panel height of 1.5 or 2 RU size, with the added capability of programming switched grounds. Switched grounds can help eliminate hard-to-find ground loops, and because it provides a more stable signal grounding structure, it's ideal for systems with audio signals coming from numerous locations.

The 489-S programmable patchbay allow users to quickly and easily change the normals and grounding of individual circuits. Normals can be changed to full-normal, half-normal or non-normal. Grounding can be changed to switched, bussed, isolated or looped. Because it's programmable, the 489-S Series can serve as the foundation for virtually any new, reconfigured or legacy installation. The end result is a patchbay that allows integrators and installers to quickly re-configure patching systems, accommodate customer change-orders, and speed service-calls.



FRONT



REAR



NO STRIPS, DUST COVER REMOVED

FRONT PROGRAMMABLE
AUDIO LONG-FRAME 1/4"
PATCHBAY

NORMALS AND
GROUNDS CAN BE
EASILY REPROGRAMMED
BY THE END USER

SPACIOUS 2x24 JACK
CONFIGURATION; 1.5 OR
2RU SIZE

REAR INTERFACE OPTIONS
INCLUDE E-3, E-90, D-25,
AND ID (PUNCHDOWN)

1/4" LONGFRAME

489-S SERIES

PROGRAMMING INSTRUCTIONS

HOW TO IDENTIFY A PROGRAMMABLE PATCHBAY

489-S Series programmable patchbays can be identified by the Programmable Icon in the upper left corner of the patchbay.



HOW TO CHANGE THE PROGRAMMING FOR A CIRCUIT

- 1: Remove the top designation strip.
- 2: Find your desired configuration in the diagram.
- 3: Arrange the programming shunts to match the appropriate diagram. Note: Each circuit can be programmed independently.
- 4: Ample shunts are provided with every programmable patchbay. All shunts should be placed vertically. Red shunts are used for grounding options. White shunts are used for normaling options.
- 5: The circuits are numbered 1-24 and correspond to vertical jack pairs reading left to right.
- 6: For the internal programming, unscrew the screws along the top edges and take off the patchbay dust cover. Locate the Internal PCB Boards inside, which are right behind the back of the jacks (for a better view, turn the rear of the patchbay toward you). There are eight PCB Boards; each one holds three circuits.
- 7: Depending on the Normal/Grounding configuration you want for each circuit, choose Internal Programming Diagram A, B or C from the blue box above and program accordingly, using the same red and white shunts.
- 8: Replace the patchbay dust cover and designation strips.

SHUNT SCHEMATICS

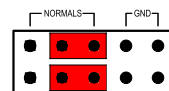
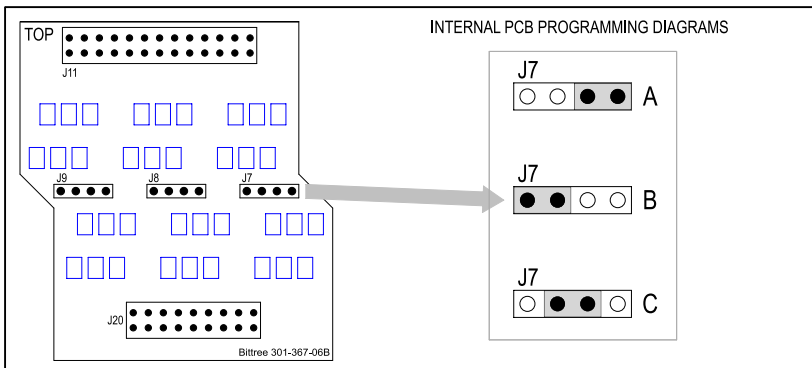
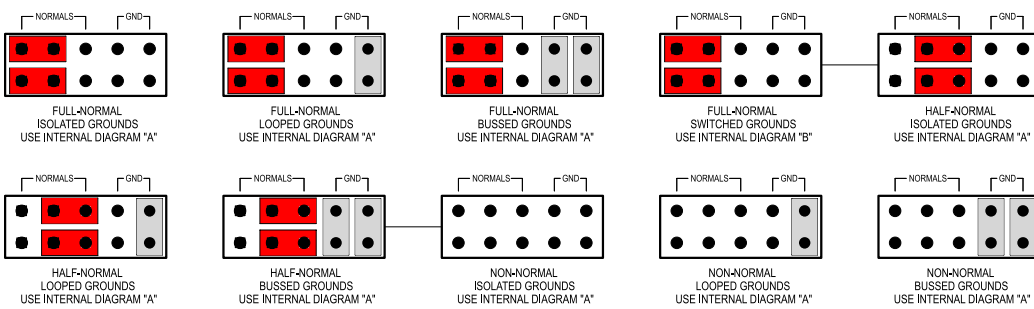

1/4" LONGFRAME

489-S SERIES

CODES / PATCHCORDS

489-S ORDERING CODES

(B 48 D C - FN S ST /E3 M 20U 12 L)

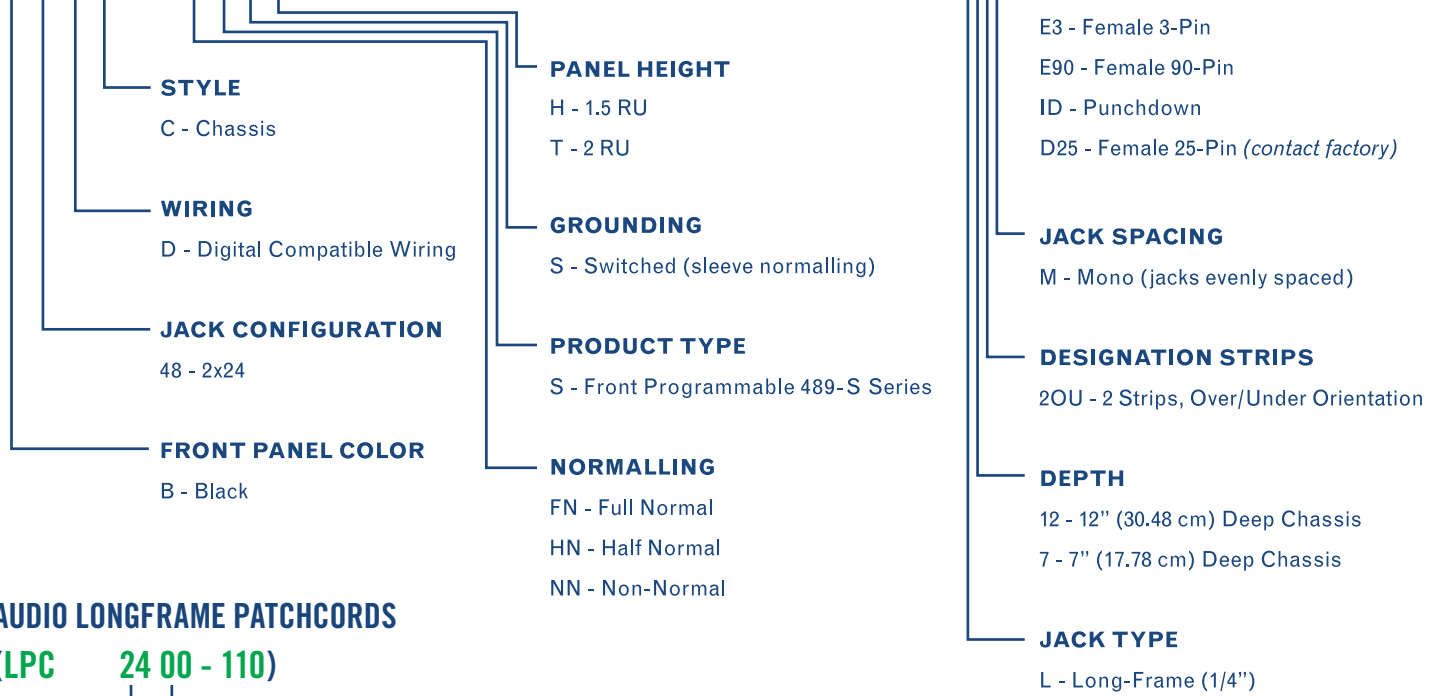

AUDIO LONGFRAME PATCHCORDS

(LPC 24 00 - 110)

LENGTH BY INCH (CM)	COLOR
24 (61)	00 - Black
36 (92)	02 - Red
48 (122)	04 - Yellow
60 (153)	05 - Green
72 (184)	06 - Blue
	07 - Purple



JACK SCHEMATICS (EXAMPLES)

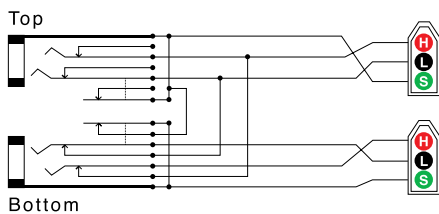

HALF NORMALED SWITCHED GROUNDS

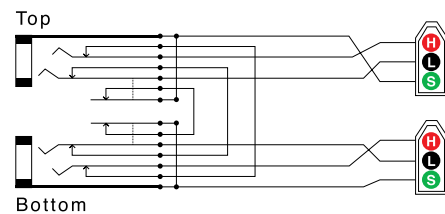

FULL NORMALED SWITCHED GROUNDS

1/4" LONGFRAME

488 SERIES

Our 488 Series features our innovative Programmable audio patchbays in a 2 x 24 1 RU size, making them ideal for mobile production and other applications in tight quarters. Programmable patchbays allow users to quickly and easily change the normals and grounding of individual circuits. Normals can be changed to full-normal, half-normal or non-normal. Grounding can be changed to bussed, isolated or looped.

Because it's programmable, the 488 Series can serve as the foundation for virtually any new, reconfigured or legacy installation. The end result is a patchbay that allows integrators and installers to quickly re-configure patching systems, accommodate customer change-orders, and speed service-calls.



FRONT



REAR

FRONT PROGRAMMABLE
AUDIO LONG-FRAME 1/4"
PATCHBAY

NORMALS AND
GROUNDS CAN BE
EASILY REPROGRAMMED
BY THE END USER

SPACIOUS 2x24 JACK
CONFIGURATION; 1RU SIZE

SMALL SIZE IS IDEAL
FOR MOBILE PRODUCTION
AND OTHER APPLICATIONS
IN TIGHT QUARTERS

REAR INTERFACE OPTIONS
INCLUDE E-3, E-90, AND D-25

1/4" LONGFRAME

488 SERIES

PROGRAMMING INSTRUCTIONS

HOW TO IDENTIFY A PROGRAMMABLE PATCHBAY

488 Series programmable patchbays can only be identified by removing the top dust cover and looking for the presence of red and white programming shunts inside.



HOW TO CHANGE THE PROGRAMMING FOR A CIRCUIT

- 1: Find your desired configuration in the diagram.
- 2: Arrange the programming shunts to match the appropriate diagram. Note: Each circuit can be programmed independently.
- 3: Ample shunts are provided with every programmable patchbay. Red shunts are placed horizontally and are used for normalling options. White shunts are placed vertically and are used for grounding options.
- 4: Replace the dust cover.

SHUNT SCHEMATICS

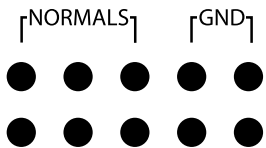

NON NORMALED
WITH ISOLATED GROUNDS

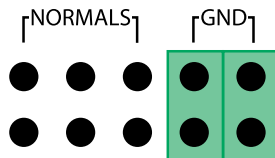

NON NORMALED
WITH BUSSED GROUNDS

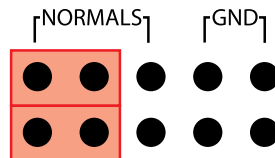

FULL NORMALED
WITH ISOLATED GROUNDS

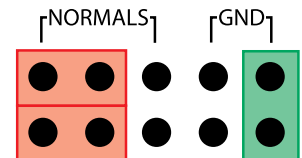

FULL NORMALED
WITH LOOPED GROUNDS

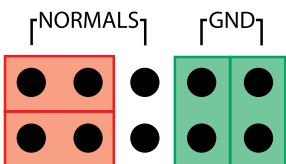

FULL NORMALED
WITH BUSSED GROUNDS

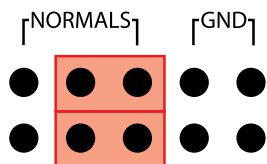

HALF NORMALED
WITH ISOLATED GROUNDS

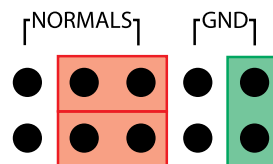

HALF NORMALED
WITH LOOPED GROUNDS

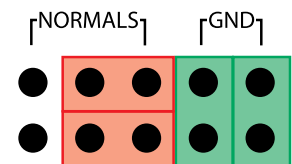

HALF NORMALED
WITH BUSSED GROUNDS

1/4" LONGFRAME

488 SERIES

CODES / PATCHCORDS

488 ORDERING CODES

(B 48 D C - F N I B S / E 3 M 2 O U 1 2 L)

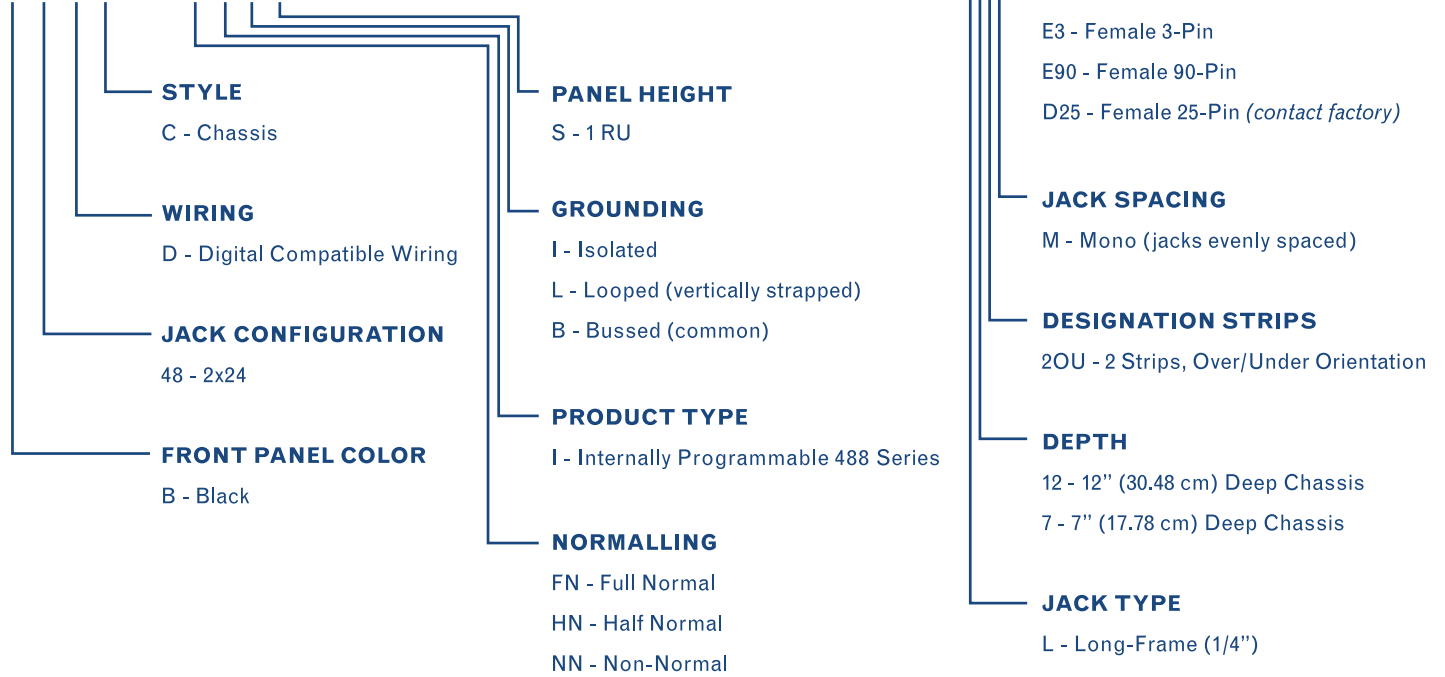

JACK SCHEMATICS (EXAMPLES)

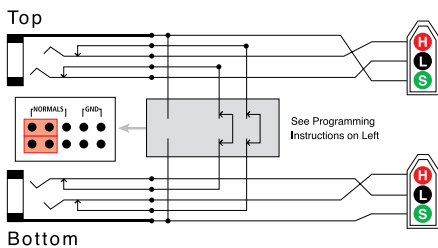

FULL NORMALED PROGRAMMABLE ISOLATED GROUNDS

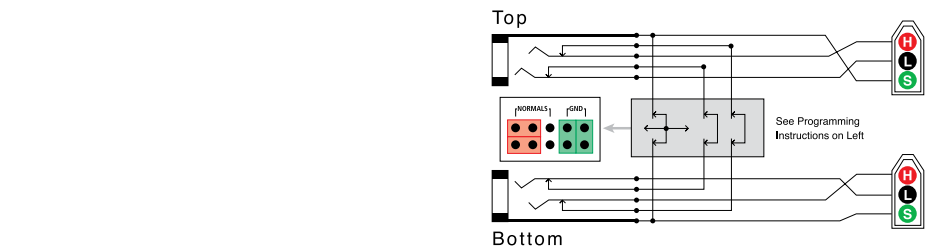

FULL NORMALED PROGRAMMABLE LOOPED GROUNDS

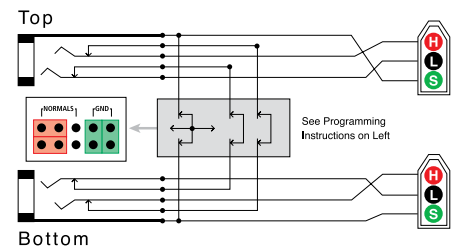

FULL NORMALED PROGRAMMABLE BUSSED GROUNDS

1/4" LONGFRAME

481 SERIES

Our 481 Series features our classic, non-programmable audio patchbays. With a jack configuration of 2 x 24, the 481 Series comes with the most options of any audio patchbay, including rear interface, normaling, grounding, jack spacing, panel color, chassis depth and rack-unit height. All Bittree audio patchbays bring you enhanced studio versatility and instant signal re-routing, and are perfect for master control and central switching I/O, audio console I/O, recording device I/O, and audio routing switcher bypass and input rerouting.

Our audio patchbays are built to AES/EBU specifications, and are internally wired with low-capacitance, shielded, 110-ohm twisted pairs. The low-capacitance characteristics make them ideal for both digital as well as analog applications.

NON-PROGRAMMABLE AUDIO LONG-FRAME 1/4" PATCHBAY

AVAILABLE WITH MORE
OPTIONS THAN ANY
AUDIO PATCHBAY,
INCLUDING REAR I
NTERFACE, NORMALING,
GROUNDING, JACK
SPACING, PANEL COLOR,
CHASSIS DEPTH AND
RACK-UNIT HEIGHT

SPACIOUS 2x24 JACK
CONFIGURATION; 1, 1.5, OR
2RU SIZE

REAR INTERFACE OPTIONS
INCLUDE E-3, E-90, D-25,
AND ID (PUNCHDOWN)



FRONT



REAR

CODES / PATCHCORDS

481 ORDERING CODES

(B 48 DC - FN L I T /E3 M 20U 12 L)

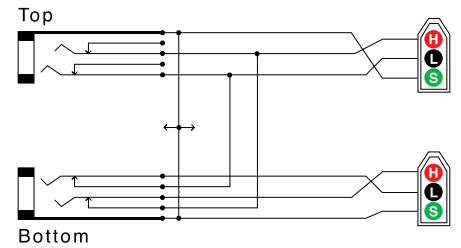
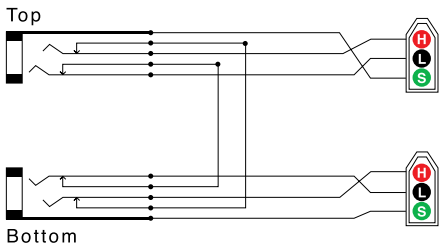
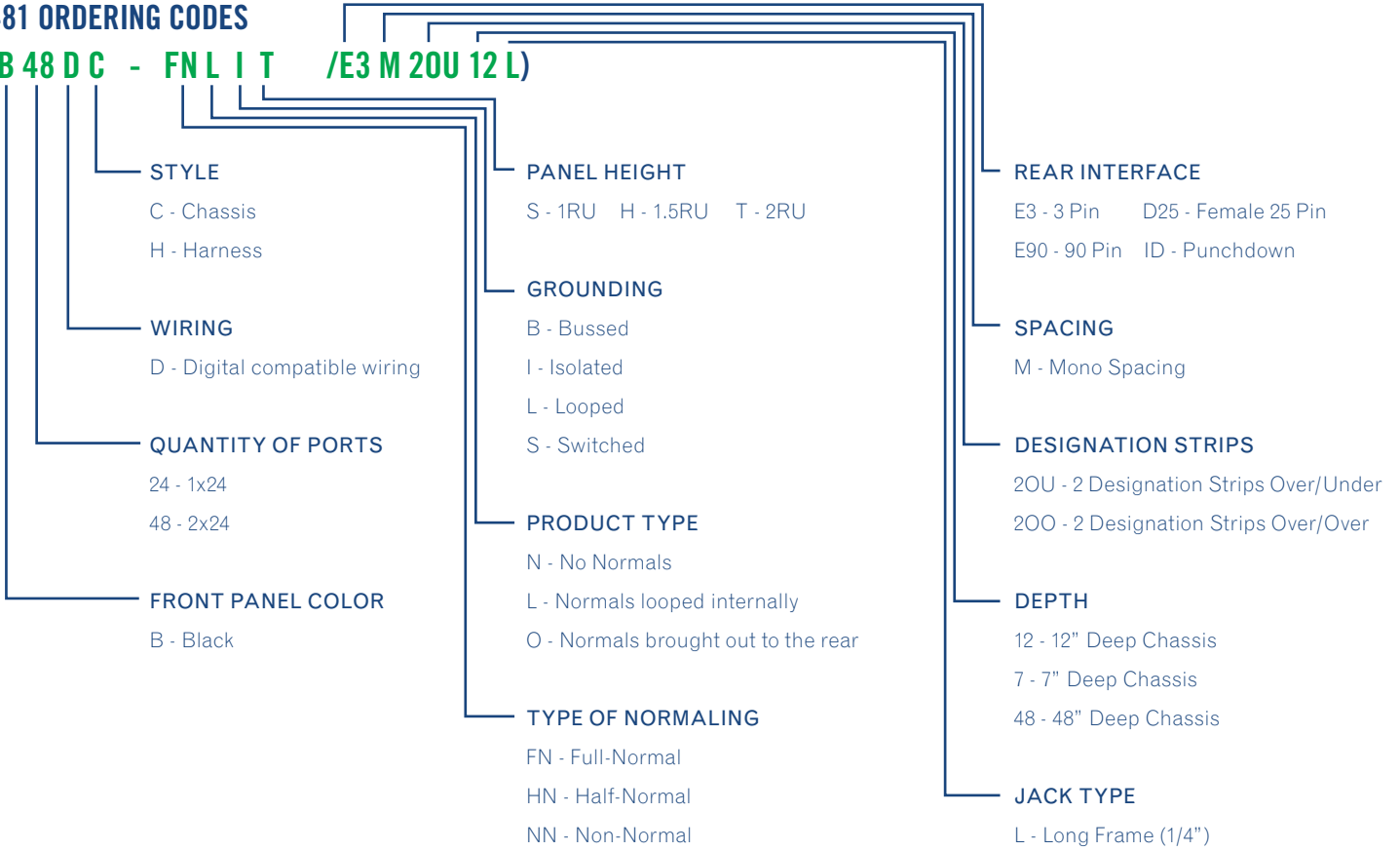

1/4" LONGFRAME

521 SERIES

Our 521 Series features our classic, non-programmable audio patchbays. With a jack configuration of 2 x 26, the 521 series is perfect for situations in which 48 point is not sufficient.



NON-PROGRAMMABLE
AUDIO LONG-FRAME 1/4"
PATCHBAY

SPACIOUS 2x26 JACK
CONFIGURATION; 1. 1.5,
OR 2RU SIZE

REAR INTERFACE OPTIONS
INCLUDE E-3, E-90, D-25,
AND ID (PUNCHDOWN)

FRONT

CODES / PATCHCORDS

521 ORDERING CODES

(B 52 D C - FN L I T /E3 M 20U 12 L)

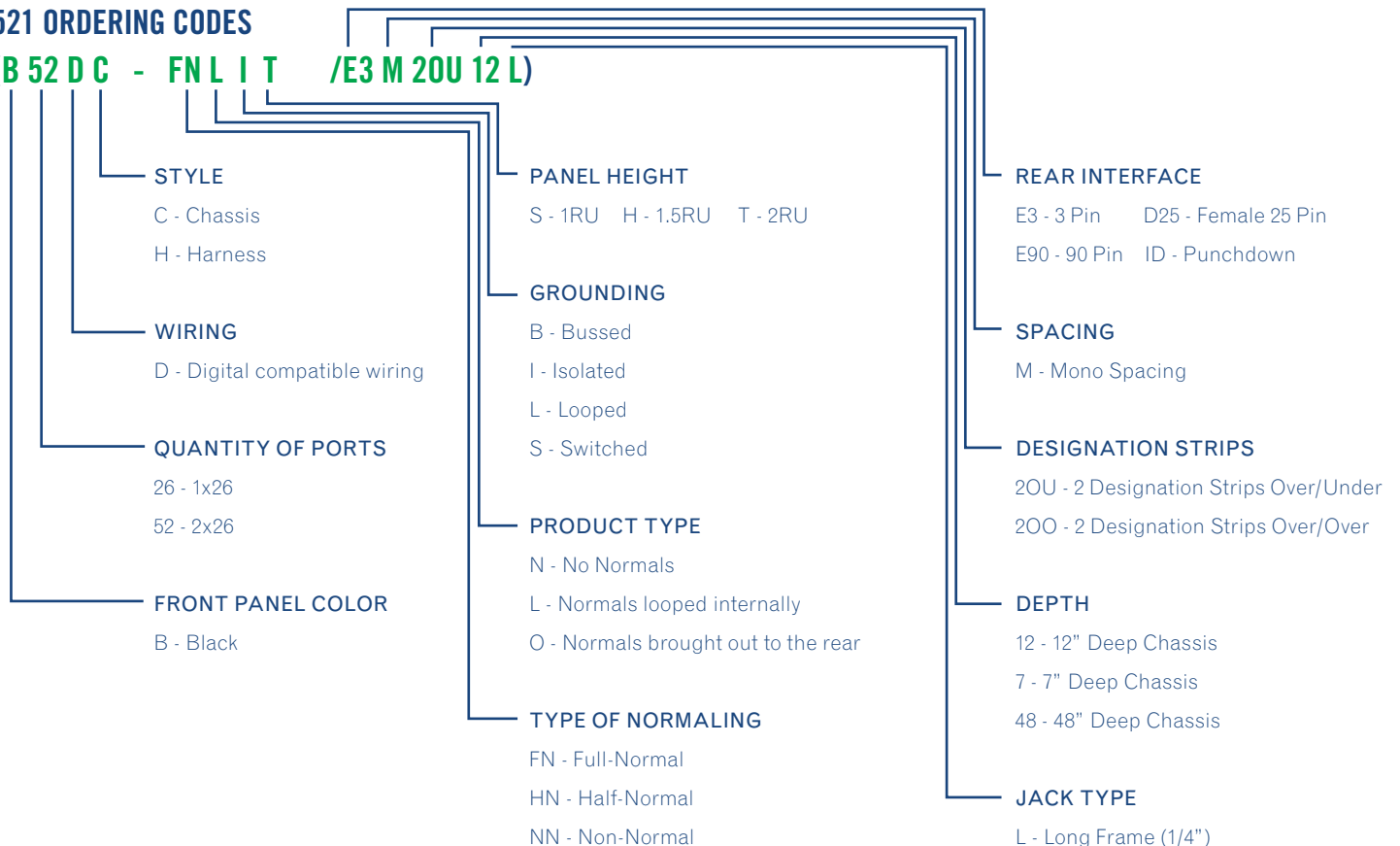

DATA

RS-422

Bittree's RS-422 Programmable and Active Data Patchbays are ideal for edit bays and machine rooms in post-production, broadcast and duplication. All Bittree data patching systems are held to strict electrical and mechanical specifications to guarantee exceptional performance in traditional serial data applications. Ideal for edit system to VTR patching; remote control delegation (e.g., Sony and Lynx systems); computer data interconnection, control panel re-routing; and central distribution of 422 signals.

RS422 ACTIVE

The RS-422 64-Port Active Patchbay is designed for remote-delegation protocols such as Sony and Lynx, and features easy-to-read connection status lights, a high-quality power supply, patchbay power-indicator light, DE9 female rear interface and normalled I/O paired ports.

RS422 PROGRAMMABLE

The RS-422 Programmable Data Patchbay is as easy as it is adaptable. To program the Normals for individual circuits, users just need to insert or remove the programming shunts located underneath the patchbay dust cover. When the shunts are inserted, the circuit will be full-normal; when the shunts are removed, the circuit will be non-normal.



RS-422

ACTIVE (422A32)

Bittree's RS-422 64-Port Active Patchbay delivers the most significant improvement in RS-422 patching since its inception, making it easier to route, manage and verify RS-422 signals. The innovation lies in the patchbay's auto-sensing transceivers that receive, interpret and re-transmit perfectly regenerated RS-422 signals, eliminating inductive and capacitive signal-distortion frequently imposed by traditional passive switches. The patchbay also serves as a powerful diagnostic tool that quickly verifies the connection status between Masters and Remotes (i.e., Controllers and VTRs). The color-coded LEDs display the transmitting and receiving status of each machine plugged into the patchbay, providing a reliable way to manage and verify RS-422 signals, as well as determine which machines are set to Master or Remote.

The RS-422 64-Port Active Patchbay also increases the reliability of RS-422 system connections. Mechanically, the system will be more reliable because it uses standard, robust bantam (TT) audio patchcords instead of card edge patchcords used by competing 2x32 patchbays that can cost twice as much. Electrically, the system will be more reliable because it transmits regenerated, pristine RS-422 signals. In addition to signal-enhancement, diagnostic capabilities and increased reliability, the form-factor of the new RS-422 64-Port Patchbay is more efficient than competing models, thanks to its 2 x 32 port configuration that perfectly matches standard routers.

The RS-422 64-Port Patchbay is ideal for edit bays and machine rooms in post-production, broadcast and duplication. And because the patchbay also serves as a repeater, it excels in today's larger networked installations, helping to provide RS-422 runs of up to 8,000 feet, depending on the termination gear. The RS-422 64-Port Active Patchbay is designed for remote-delegation protocols such as Sony and Lynx, and features easy-to-read connection status lights, a high-quality power supply, patchbay power-indicator light, DE9 female rear interface and normalised I/O paired ports. The SMPTE 207 compliant, 2 rack-unit patchbay is ruggedly built yet finely finished, and is housed in a 12" chassis with a powder-coat finish and extra-wide designation strips.

FEATURES

- Color-coded LEDs make it easier to route, verify and diagnose RS-422 signals
- Auto-sensing transceivers transmit perfectly re-generated RS-422 signals for longer cable runs
- Rear port auto-senses/auto-configures for master or remote operation
- Uses reliable bantam audio patchcords
- SMPTE 207M compliant; accommodates remote delegation protocols such as Sony and Lynx
- Easy-to-read connection-status lights and patchbay power indicator light
- Includes high-quality, medical-grade power supply; optional dual power supply for on-air applications.
- Rugged nickel-plated, cold-rolled steel box-frame construction; jacks rated to 30,000 minimum insertion cycles
- Panels made from 3/16" solid aluminum with black durable powder-coat finish
- 2x32 ports, DE9 female rear interface, 2RU, 12" deep chassis; Extra-wide designation strips



FRONT

RS-422

ACTIVE

SPECIFICATIONS

REAR INTERFACE CONNECTIONS

SIGNAL: DE9 Female

LIFE CYCLE: > 10,000 insertion cycles

POWER: Locking Mini Power Connector L722A

FRONT INTERFACE CONNECTIONS

SIGNAL: Bantam (TT) jacks

LIFE CYCLE: > 30,000 insertion cycles

MAXIMUM INPUT TO OUTPUT PROPAGATION DELAY: 1250 ns

PATCHCORD: Standard Bantam (TT) patchcord

RS-422 PATCHCORD

(BPC 24 00 - 110)

LENGTH BY INCH (CM)

24 (61)

36 (92)

48 (122)

60 (153)

72 (184)

COLOR

00 - Black

02 - Red

04 - Yellow

05 - Green

06 - Blue

07 - Purple

DE9 SLIM HOOD

The profile of the DE9 Slim Hood allows users to fit up to 32 connectors in each row and take advantage of all 64 ports in the new RS-422 64-Port Active Patchbay. The DE9 Slim Hood is easy to assemble, comes with a rugged tie-wrap strain relief to ensure solid connections, and features slotted thumb screws for maximum convenience.

PART NUMBERS:

DE9Slim1 one unit

DE9Slim16 set of 16

DE9Slim8 set of 8

DE9Slim32 set of 32

DE9 Slim Hoods not included with RS-422 64-Port Active Patchbay



POWER REQUIREMENTS

INPUT: 100-120V AC, 47-63Hz; 0.75 amps

OUTPUT: 5+0.1 volts DC Regulated; 2.4 amps max

POWER SUPPLY CONNECTOR: Locking Mini Power Plug S760K

ENVIRONMENTAL

OPERATING TEMPERATURE: 0°C to 70°C

STORAGE TEMPERATURE: -55°C to 85°C

SCHEMATICS

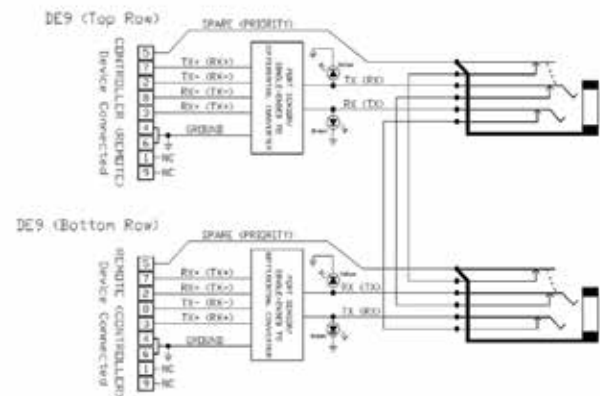

PATCHBAY PRODUCT NUMBERS

RS-422 64-Port Active Patchbay, with single power supply (**422A32**)

RS-422 64-Port Active Patchbay, with dual power supply (**422A32-D**)

POWER SUPPLY

This high-quality power supply was designed exclusively for the RS-422 64-Port Active Patchbay. Screw lock-downs ensure power supply stays connected. Low-profile wall-plug helps power supply stay plugged in. 721 cord, 5 volt, 2.4 amp.

Power Supply(s) included with RS-422 64-Port Active Patchbay.



RS-422

PROGRAMMABLE

Our RS-422 Programmable Data Patchbay, expressly designed to meet the needs of RS-422 serial data patching typically required in television broadcast or postproduction facilities, allows you to switch circuits between full-normal and non-normal and back again quickly, easily and reliably. The RS-422 Programmable Data Patchbay is as easy as it is adaptable. To program the Normals for individual circuits, users just need to insert or remove the programming shunts located underneath the patchbay dust cover. When the shunts are inserted, the circuit will be full-normal; when the shunts are removed, the circuit will be non-normal.

This flexibility means the RS-422 Programmable Data Patchbay can serve as the foundation for virtually any new, reconfigured or legacy installation. It also means that regardless of any design changes that arise during installation, it can always be re-programmed as needed right on the spot. The end result is that the RS-422 Programmable Data Patchbay allows integrators and installers to quickly re-configure patching systems, accommodate customer change-orders, and speed service-calls. It also allows system designers to more confidently assemble equipment lists and more accurately develop quotes earlier in the proposal process.

The RS-422 Programmable Data Patchbay features six-wire circuits, accommodating RS422 signals and providing two extra circuits for additional applications and protocols. The patchbay handles bi-directional signals such as RS-422, RS-232 and other general purpose interface applications. The RS-422 Programmable Data Patchbay features a D9 female rear interface and is SMPTE 207 compliant. The 2 rack-unit patchbay is ruggedly built yet finely finished, and is housed in a 12" chassis with a powder-coat finish and extra-wide designation strips. The RS-422 Programmable Data Patchbay is ideal for edit bays and machine rooms in post-production, broadcast and duplication, and can also accommodate remote-delegation protocols such as Sony and Lynx.

All Bittree data patching systems are held to strict electrical and mechanical specifications to guarantee exceptional performance in traditional serial data applications. Ideal for edit system to VTR patching; remote control delegation (e.g., Sony and Lynx systems); computer data interconnection, control panel re-routing; and central distribution of 422 signals.

FEATURES

- Programming shunts allow users to easily change between full-normal and non-normal circuits
- Red/white programming shunts are located inside, under the patchbay dust cover. Insert shunts to make the circuit full-normal; remove shunts to make the circuit non-normal.
- Robust six-wire circuits accommodate RS422 signals and provide two extra circuits for additional applications and protocols.
- Handles bi-directional signals such as SMPTE 207M RS-422, RS-232 and other purpose interface applications.
- Available formats include 2x6 and 2x12 in 1RU, and 2x12, 2x18 and 2x24 in 2RU, all in 12" deep chassis.
- Precision-stamped reinforced steel jack frame; jacks rated to 30,000 minimum insertion cycles
- Panels made from 3/16" solid aluminum with black durable powder-coat finish



FRONT

PROGRAMMABLE

PROGRAMMING INSTRUCTIONS

HOW TO IDENTIFY A PROGRAMMABLE PATCHBAY

RS-422 Programmable Data patchbays can be identified by their product number. Locate the product number sticker toward the back of the left side panel. If the product number contains either an FI or NI in the product number, it is programmable.

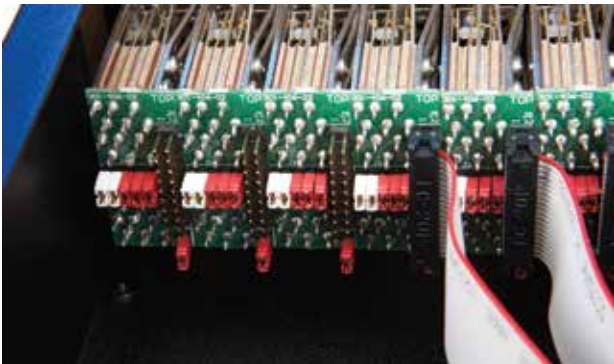

HOW TO CHANGE THE PROGRAMMING FOR A CIRCUIT

- 1: Remove the patchbay dust cover. Locate the Internal PCB boards inside, which are right behind the back of the jacks (for a better view, turn the rear of the patchbay toward you). There are 24 PCB Boards; each one holds one circuit.
- 2: Programming options are full normal or non-normal. Find your desired configuration in the diagram above.
- 3: Ample red and white shunts are provided with every programmable patchbay. Arrange the programming shunts on the PCB Boards to match the appropriate diagram. When the programming shunts are inserted, the circuit will be full-normal; when the shunts are removed, the circuit will be non-normal. Note: Each circuit can be programmed independently.
- 4: Replace the dust cover.

SHUNT SCHEMATICS

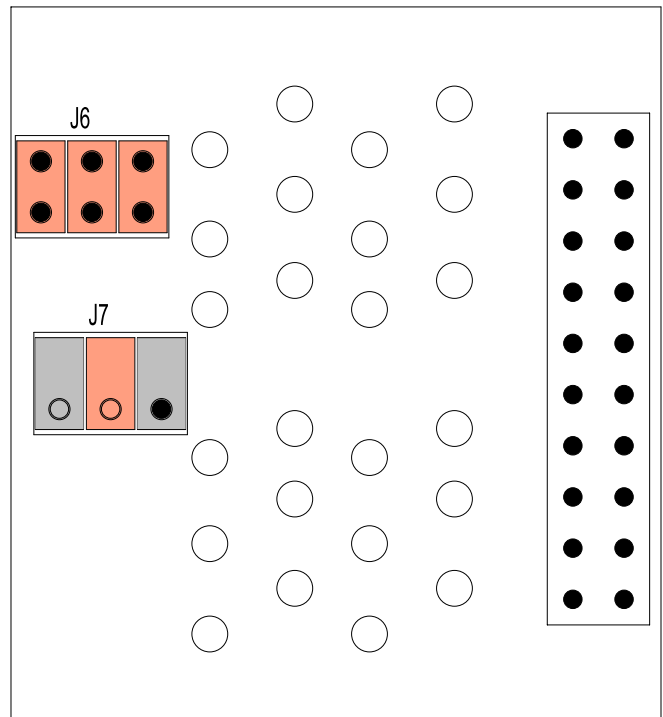
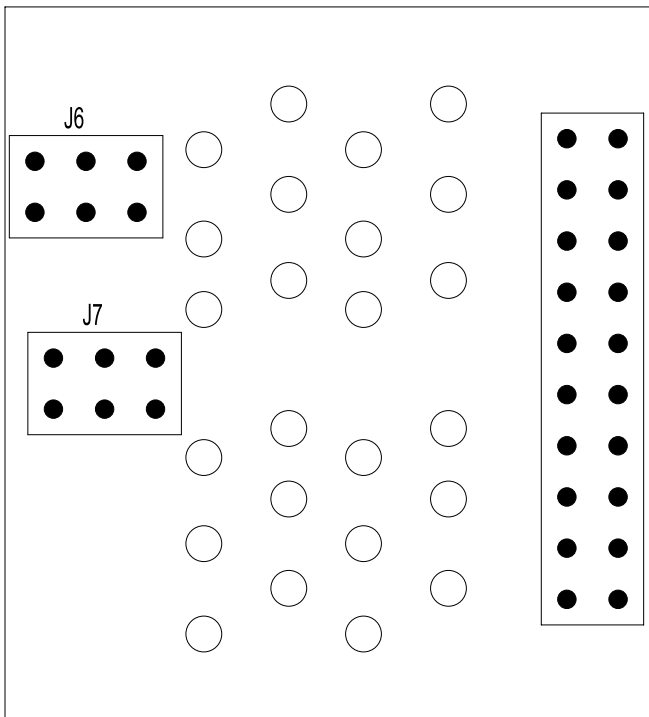

RS-422

PROGRAMMABLE

DUAL BANTAM (TT)

(B 422 - F16 T / 24)

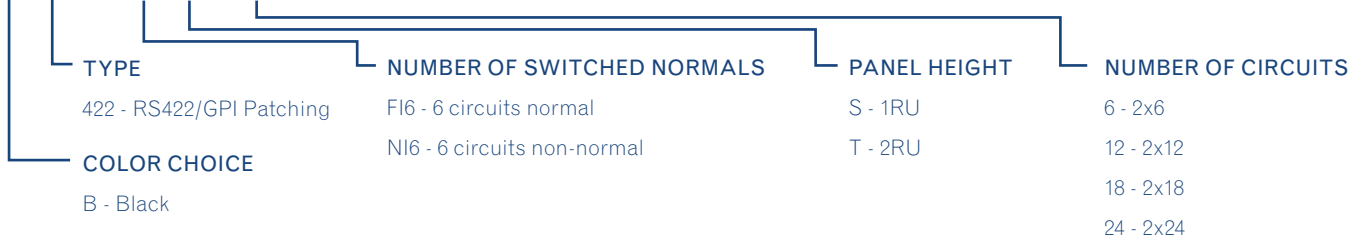

DUAL BANTAM (TT) SIX-WIRE

(GPI 24 00)



DUAL BANTAM (TT)

(DPC 24 00)

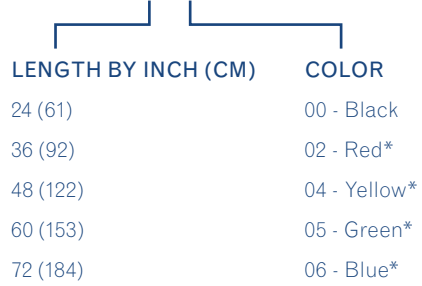

* Available in 24" and 36" only

SCHEMATICS

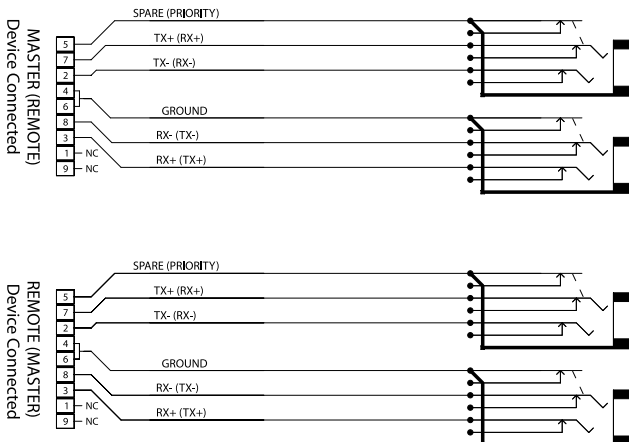

NON-NORMALED VIEW

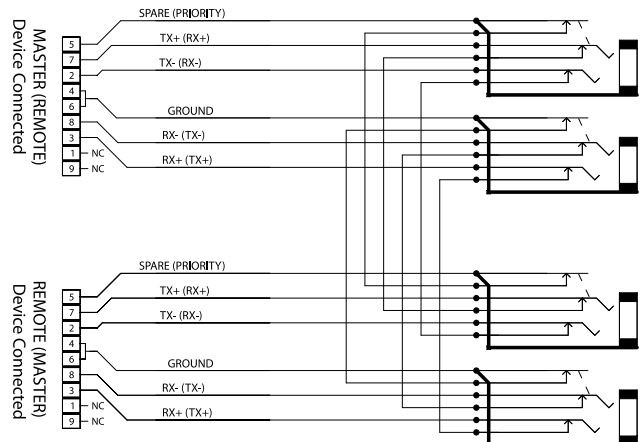

FULL-NORMALED VIEW

DATA

FIBER & COPPER

Recognizing the influence of emerging technologies in broadcast centers, as well as new environments for content creation and distribution, Bittree has expanded the potential for patching to accommodate Fiber-optic, Ethernet, and other data related cabling. As the boundaries between broadcast, Pro AV, and IT become less distinct, Bittree provides unique solutions that allow greater flexibility to fit the needs of a variety of professionals. Bittree high-performance fiber and copper patching products offer custom solutions necessary for the rapid expansion of creation and distribution of content.

FIBER-OPTIC SOLUTIONS

Flush-mount modular panels populated with fiber-based keystone adapters/couplers:

- LC/LC
- SC/SC
- ST/ST

Modular patch panels and enclosures for LGX® style fiber adapter panels

Fiber-optic patch cables and looping plugs

GIGABIT ETHERNET SOLUTIONS

Flush-mount modular keystone panels populated with various RJ45 (8P8C) couplers:

- CAT 6, RJ45 jack to RJ45 jack, with or without shielding
- CAT 6, RJ45 jack to 110 punchdown, unshielded
- CAT 6A, RJ45 jack to 110 punchdown, shielded

CAT 6 fixed 110 punchdown patch panels

CAT 6 shielded and unshielded patch cables

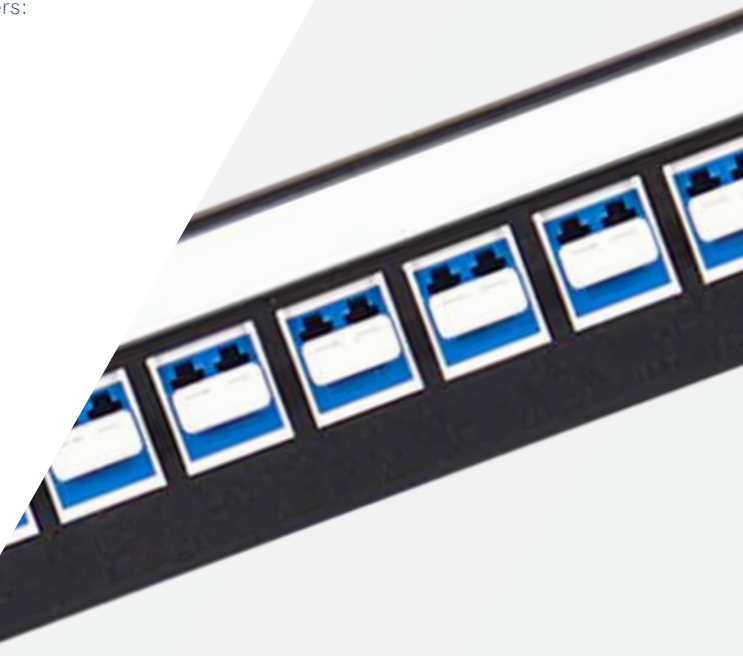

FIBER & COPPER

FIBER-OPTIC SOLUTIONS

Bittree offers an extensive line of modular fiber-optic feed-through panels utilizing industry standard LC/LC, SC/SC, and ST/ST “keystone” adapters. These panels are the first to incorporate designation strips, enhancing circuit identification. The keystone modular design enables the installation of a variety of connector types within the same panel. The included 6” (15.24 cm) rear lacing bar simplifies cable dressing and can be removed when alternative or conflicting cable management techniques are employed. Currently available in a 1 RU form factor with a single row of 24 adapters, our fiber-optic feed-through panels provide you with the flexibility you need to meet a variety of project requirements.



ORDERING CODES

(DSKP 124 B - LC)

CONNECTOR TYPE

LC - LC/LC
LCA - LC/LC, Angle Polish
SC - SC/SC
ST - ST/ST

JACK CONFIGURATION

124 - 1x24

PRODUCT TYPE

DSKP - Data Systems Keystone Panel

OUR MODULAR FIBER-OPTIC FEED-THROUGH PANELS ARE AVAILABLE WITH LC, SC, AND ST KEYSTONE ADAPTERS

PANELS CAN BE POPULATED WITH VARIOUS COMBINATIONS OF KEYSTONE ADAPTERS

ADAPTERS ARE PREINSTALLED OR PACKAGED SEPARATELY DEPENDING ON THE TYPE

1 RU PANEL WITH 1X24 JACK CONFIGURATION

SILK SCREENED NUMBERING ON REAR PANEL

FASTON LUGS INCLUDED ON REAR PANEL FOR BUSSED AND BONDED GROUNDING SCHEMES

ADDITIONAL CONFIGURATIONS AVAILABLE – PLEASE CONTACT US FOR MORE INFORMATION

FIBER & COPPER

FIBER-OPTIC SOLUTIONS

FIBER-OPTIC PANELS AND ENCLOSURES



ITEM: DSFB124-ST
ST/ST FEED-THROUGH ENCLOSURE
1X24, 1RU



ITEM: DSFP13M*
LGX® STYLE ADAPTER PANEL
1X3, 1RU



ITEM: DSFB206*
LGX® STYLE ADAPTER ENCLOSURE
2X3, 2 RU



ITEM: DSPLC-0050M**
LC/LC LOOPING PLUG (LOOPBACK)
50/125 µm MULTI-MODE, 0 dB ATTENUATION



ITEM: DSPLC-0009S**
LC/LC LOOPING PLUG (LOOPBACK)
9/125 µm SINGLE-MODE, 0 dB ATTENUATION



ORDERING CODES

FIBER-OPTIC PATCH CABLES ***

(DSP 36 04 - LC/LC S)

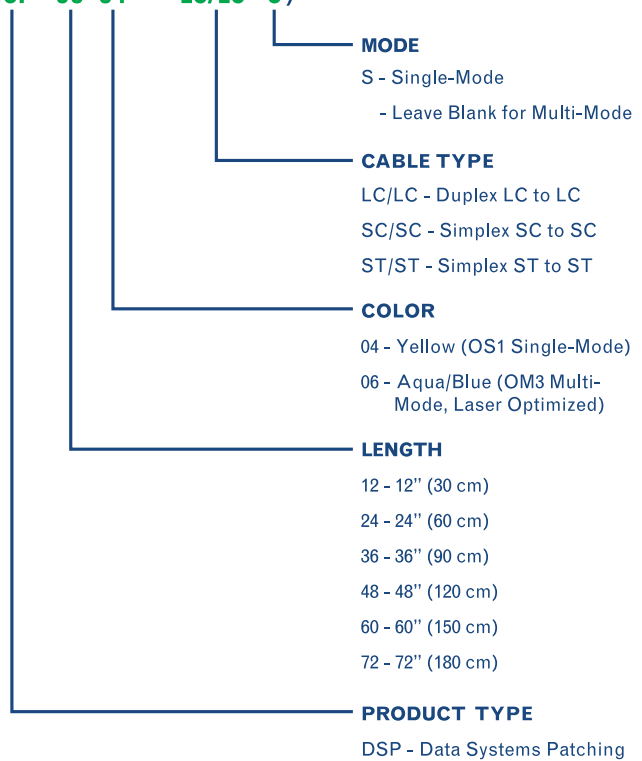

FIBER-OPTIC PATCH CABLES

See ordering codes diagram for options

* Numerous fiber adapter modules and cassettes available
** Available with different fixed attenuation levels

*** Additional lengths, colors, and connector types (i.e. MPO/MTP) available
LGX® is a registered trademark OFS, a Furukawa Electric Co., Ltd. company.

FIBER & COPPER

GIGABIT ETHERNET SOLUTIONS

The Broadcast and Pro AV industries have been increasingly receptive to Ethernet-based solutions due to their overall versatility and a changing infrastructure landscape. We have introduced a number of premium feed-through and bulkhead patch panels to meet the needs of our customers who have embraced these alternative formats.

MODULAR KEYSTONE FEED-THROUGH PANELS



OUR MODULAR ETHERNET FEED-THROUGH PANELS ARE AVAILABLE WITH JACK-TO-JACK OR JACK-TO-110 PUNCHDOWN MODULES

PANELS CAN BE POPULATED WITH VARIOUS COMBINATIONS OF KEYSTONE ADAPTER MODULES

ADAPTERS ARE PREINSTALLED OR PACKAGED SEPARATELY DEPENDING ON THE TYPE

SILK SCREENED NUMBERING ON REAR PANEL

FASTON LUGS INCLUDED ON REAR PANEL FOR BUSSED AND BONDED GROUNDING SCHEMES

1 RU PANEL WITH 1X24 JACK CONFIGURATION

ORDERING CODES

RJ45 (8P8C) MODULAR KEYSTONE PANELS
(**DSKP 124 B - C6APS**)

CONNECTOR TYPE

C6F - CAT 6, RJ45 to RJ45, Unshielded
C6FS - CAT 6, RJ45 to RJ45, Shielded
C6P - CAT 6, RJ45 to 110, Unshielded
C6APS - CAT 6A, RJ45 to 110, Shielded

JACK CONFIGURATION

124 - 1x24

PRODUCT TYPE

DSKP - Data Systems Keystone Panel

Additional configurations available; please contact us for more information

FIBER & COPPER

GIGABIT ETHERNET SOLUTIONS

CAT 6 Fixed Position RJ45 (8P8C) to 110 Punchdown Panels



AVAILABLE IN 1 RU WITH A 1X24 JACK CONFIGURATION OR 2 RU WITH A 2X24 JACK CONFIGURATION

SILK SCREENED NUMBERING ON FRONT PANEL BY DEFAULT; PANELS CAN BE CONFIGURED WITH DESIGNATION STRIPS

RJ45 (8P8C) PATCH CABLES

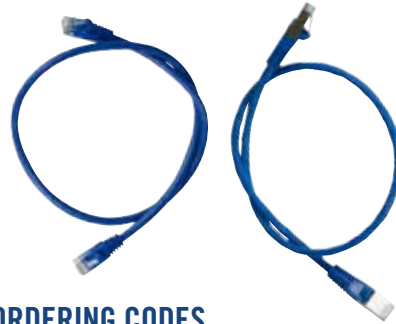

ORDERING CODES

RJ45 (8P8C) PATCH CABLES

(**DSP 36 06 - CAT6S**)

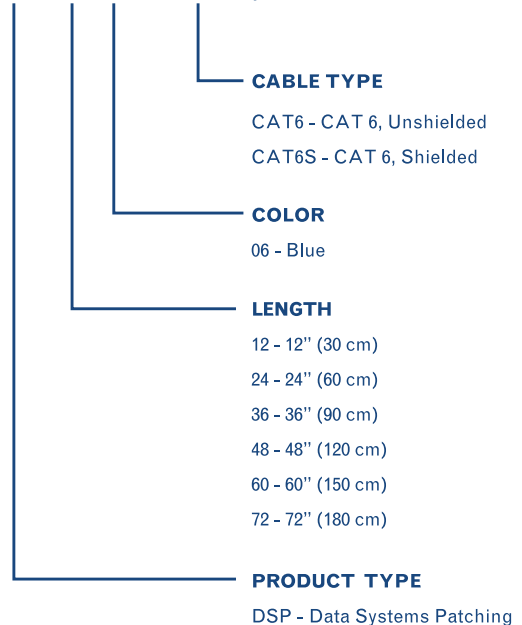

ORDERING CODES

RJ45 (8P8C) GIGABIT ETHERNET PANELS

(**DSGIGE 124 D**)

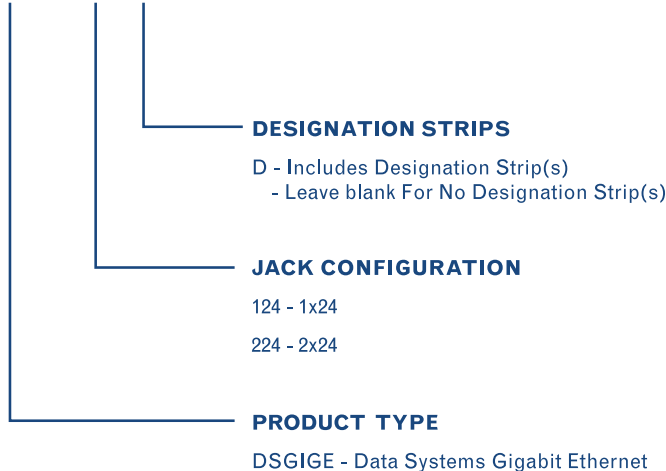

COAX & TWISTED PAIR

Bittree offers a wide variety of feed-through panels for both coaxial and twisted-pair wiring. These feed-through panels have multiple functions which often make them a perfect addition to your patching system, solving a wide range of needs. Some of the creative ways these panels have been used include acting as additional bulk heads on the rear of equipment racks, adapting one connector type to another, which may be simpler than re-terminating cabling with different connector types, serving as an intermediate d-mark location point on long cable runs or modular system designs.

COAXIAL FEED THROUGH

Typically used for video applications. They can often act as an intermediate d-mark in a long cable run.

TWISTED PAIR FEED THROUGH

Typically used in audio applications. They act as an intermediate d-mark location in long cable runs and allow designers to build flexibility into modular racks.



COAX & TWISTED PAIR

COAX



HD COMPATIBLE RATED TO 4GHZ

BNC CONNECTORS ON THE FRONT AND REAR OF PANEL

HEIGHT OF 1RU OR 2RU WITH CONFIGURATIONS OF 1X16, 1X24, 1X32, 2X16, OR 2X24

SILK SCREENED WITH OPTIONAL DESIGNATION STRIPS

LACING BARS FOR THE FRONT AND REAR OF THE PANEL

COAX & TWISTED PAIR

COAX

ORDERING CODES

(BH - B 1 16 A 0 B4)

DESIGNATION

- 0 - None Included
- 1 - 1 Des. Strip (1RU)
- 2 - 2 Des. Strip (2RU)

BNCs PER ROW

- 16 - 16 BNCs Per Row
- 24 - 24 BNCs Per Row
- 32 - 32 BNCs Per Row

NUMBER OF ROWS

- 1 - 1 Row
- 2 - 2 Rows

FRONT PANEL COLOR

- B - Black

PANEL TYPE

- BH - Bulk Head

BNC TO BNC

- 24" BNC TO BNC CABLE, BLACK (**VBB2400-75**)
- 36" BNC TO BNC CABLE, BLACK (**VBB3600-75**)
- 48" BNC TO BNC CABLE, BLACK (**VBB4800-75**)
- 72" BNC TO BNC CABLE, BLACK (**VBB7200-75**)
- 120" BNC TO BNC CABLE, BLACK (**VBB12000-75**)



PRODUCT NUMBERS

COAXIAL

- 1RU 1X16 BNC 4GHZ ISO FEED-THRU 75OHM BLACK (**BH-B116A0B4**)
- 2RU 1X16 BNC 4GHZ ISO FEED-THRU 75OHM2DES BLACK (**BH-B116A2B4**)

- 1RU 1X24 BNC 4GHZ ISO FEED-THRU 75OHM BLACK (**BH-B124A0B4**)
- 2RU 1X24 BNC 4GHZ ISO FEED-THRU 75OHM2DES BLACK (**BH-B124A2B4**)

- 1RU 1X32 BNC 4GHZ ISO FEED-THRU 75OHM BLACK (**BH-B132A0B4**)

- 2RU 2X16 BNC 4GHZ ISO FEED-THRU 75OHM BLACK (**BH-B216A0B4**)
- 2RU 2X16 BNC 4GHZ ISO FEED-THRU 75OHM2DES BLACK (**BH-B216A2B4**)

- 2RU 2X24 BNC 4GHZ ISO FEED-THRU 75OHM BLACK (**BH-B224A0B4**)
- 2RU 2X24 BNC 4GHZ ISO FEED-THRU 75OHM2DES BLACK (**BH-B224A2B4**)

(VBB 36 02 - 75)

IMPEDENCE

- 75 Ohm

COLOR

- 00 - Black
- 02 - Red
- 05 - Green
- 06 - Blue

LENGTH BY INCH (CM)

- 24 (60)
- 36 (90)
- 48 (1.2 meters)
- 72 (2 meters)
- 120 (3 meters)

CABLE TYPE

- BNC to BNC, Coaxial

COAX & TWISTED PAIR

TWISTED PAIR

Our XLR to E3 panel assemblies are one such example of a unique solution to this problem. Now cables terminated with XLR connectors can be plugged into our XLR to E3 panel, and E3 cables can extend to the rear interface or your equipment or directly to your patchbay. Rack Mount harness assemblies with E3 or punchdown (ID) allow system designers and integrators to build flexibility into modular racks. They also act as an intermediate cross connect d-mark location.

PRODUCT NUMBERS

E3 SECTION

HARNESS 24PT 1RU E3F 1X24 PANEL ASSEMBLY (RP-24HS/E3-A)

HARNESS 32PT 1RU E3F 1X32 PANEL ASSEMBLY (RP-32HS/E3-A)

HARNESS 48PT 1RU E3F 2X24 PANEL ASSEMBLY (RP-48HS/E3-A)

HARNESS 48PT 2RU E3F 2X24 PANEL ASSEMBLY (RP-48HT/E3-A)

HARNESS 96PT 1RU E3F 2X48 PANEL ASSEMBLY (RP-96HS/E3-A)

HARNESS 96PT 2RU E3F 2X48 PANEL ASSEMBLY (RP-96HT/E3-A)
2RU (2X48) E3F BULKHEAD FEED-THRU (BH-E3F2X48)

Assembly E3F panels supplied with all mating connectors and contacts

PUNCHDOWN SECTION

REAR PANEL HARNESS TYPE 96 IDC TO IDC ASSEMBLY (RP-96HT/ID-A)

XLR TO E3

1RU BLK 1X16 M XLR TO E3F 3IN DEEP (SBCCRB01)

1RU BLK 1X16 F XLR TO E3F 3IN DEEP (SBCCRB02)

1RU BLK 1X16 8F/8M XLR TO E3F 3IN DEEP (SBCCRB09)

D SUB FEED-THROUGH

BLACK 2RU (2X24)DB9-F BULKHEAD FEED-THRU (BH-DB92X24)

FEATURES

- Our feed-through Panels for Twisted Pair come in a variety of options
- Interface options include punchdown (ID), E3, DB9, or XLR
- Harness assemblies for Punchdown (ID) and E3
- XLR panels come in 1RU panels with 1x16 connectors with different combinations of male and female XLR on the front, E3 on the rear



DATA

INTEGRATED

The revolutionary idea behind Bittree's Integrated Patchbays is to combine the three main patching requirements audio, video and data into a single integrated unit. Our Integrated patchbays therefore have the same professional quality and finish as the rest of our line, avoiding the loose pieces and sloppy look of modular patchbays offered by other companies.

Integrated patchbays are ideal for environments such as edit rooms and professional home studios that have multiple types of patching requirements (i.e., audio, video and data), but that have a minimal number of patching requirements. They are a cost-effective way to have the convenience, functionality and reliability of a multiple-patch system, without having to purchase three separate patchbays.

VIDEO PORTION

WECO or MINI-WECO

AUDIO PORTION

TT BANTAM or 1/4" LONGFRAME

RS422 PORTION

On select IPS Patchbays



INTEGRATED

INTEGRATED PATCHBAY



FRONT



REAR

VIDEO FEATURES

- High-bandwidth performance for SD/SDI, HD/SDI, and 3 Gb/s applications available
- Jacks conform to SMPTE 292M and SMPTE 424M
- Available in both Mini-WECO and WECO formats
- BNC rear interface
- True 75ohm impedance with low return loss
- Jacks are isolated from the panel

DATA FEATURES

- Handles bi-directional signals such as SMPTE 207M RS-422, RS-232 and other general purpose interface applications
- Robust six-wire circuits accommodate RS422 signals and provide two extra circuits for additional applications and protocols
- Jacks rated to 30,000 minimum insertion cycles
- Precision-stamped reinforced steel jack frame
- Available as normaled or non-normaled
- D9 female rear interface

AUDIO FEATURES

- Bantam (TT) or Long Frame (1/4") Audio
- Jacks rated to 30,000 minimum insertion cycles
- Copper-nickel-silver alloy leaf springs with gold-plated cross bar switching contacts and nickel-plated sleeve bushings
- Precision-stamped reinforced steel jack frame
- Gold-plated contacts used in E3 rear interface
- Wired with low-capacitance, AES/EBU-rated, shielded, twisted pair
- Available in full normal, half-normal or non-normal
- Mating audio connectors and contacts are included

PANEL FEATURES

- Available in 1.5 or 2 rack units (RU)
- Panels made from 3/16" solid aluminum with a durable powder-coat finish
- 12" or 7" deep chassis
- Black or gray front panel
- Large user-friendly designation strips

INTEGRATED

INTEGRATED PATCHBAY



FRONT



REAR

PRODUCT NUMBERS

VIDEO 2X10 (**2WT**); AUDIO 2X20 (**FNLLT/E3**); DATA 2X4 (**N4T**) (**BIPS-4A**)

VIDEO 2X16 (**2MWTHD**); AUDIO 2X24 (**FNLIT/E3**) (**BIPS-74**)

VIDEO 2X12 (**2WTHD**); AUDIO 2X12 (**FNLIT/E3**) (**BIPS-165**)

VIDEO 2X12 (**2WTHD**); AUDIO 2X24 (**FNLBT/E3**) (**BIPS-198**)

VIDEO 2X16 (**2MWTHD**); AUDIO 2X16 (**FNLIT/E3**); DATA 2X4 (**FI6**) (**BIPS-195**)

VIDEO 2X8 (**2MWTHD**); AUDIO 2X32 (**FNLIT/E3**) (**SBCIPS03**)

ACCESSORIES

PATCHCORDS/ LOOPING PLUGS



AUDIO (TT) BANTAM
BPC PATCHCORDS
(BPC 24 00 - 110)

COLOR	LENGTH (CM)
00 - Black	24 (61)
02 - Red	36 (92)
04 - Yellow	48 (122)
05 - Green	60 (153)
06 - Blue	72 (184)
07 - Purple	



DUAL (TT) BANTAM
DPC PATCHCORDS
(DPC 24 00)

COLOR	LENGTH (CM)
00 - Black	24 (61)
02 - Red	36 (92)
04 - Yellow	48 (122)
05 - Green	60 (153)
06 - Blue	72 (184)
07 - Purple	



AUDIO (1/4") LONGFRAME
LPC PATCHCORDS
(LPC 24 00 - 110)

COLOR	LENGTH (CM)
00 - Black	24 (61)
02 - Red	36 (92)
04 - Yellow	48 (122)
05 - Green	60 (153)
06 - Blue	72 (184)
07 - Purple	



VIDEO COMPONENT
MINI-WECO PATCHCORDS
(VPCM 24 00 - 75)

COLOR	LENGTH (CM)
00 - Black	24 (61)
02 - Red	36 (92)
04 - Yellow	48 (122)
05 - Green	60 (153)
06 - Blue	72 (184)
07 - Purple	



VIDEO COMPONENT RGBHV
MINI-WECO PATCHCORDS
(CPCM HV 24 00 - 75)

COLOR	LENGTH (CM)
00 - Black	24 (61)
	36 (92)
	48 (122)
	60 (153)
	72 (184)



VIDEO
WECO PATCHCORDS
(VPC 24 00 - 75)

COLOR	LENGTH (CM)
00 - Black	24 (61)
02 - Red	36 (92)
04 - Yellow	48 (122)
05 - Green	60 (153)
06 - Blue	72 (184)
07 - Purple	



VIDEO COMPONENT RGBHV
WECO PATCHCORDS
(CPC 24 00 - 75)

COLOR	LENGTH (CM)
00 - Black	24 (61)
	36 (92)
	48 (122)
	60 (153)
	72 (184)



FIBER PATCHCORDS
(DSP1206 - LC)

COLOR	LENGTH (CM)
04 - Yellow	24 (61)
06 - Blue	36 (92)
	48 (122)
	60 (153)
	72 (184)

CABLE TYPE
LC/LC
SC/SC
ST/ST



VIDEO
WECO LOOPING PLUGS
(LP 75 00)

COLOR
00 - Black
02 - Red
04 - Yellow
05 - Green
06 - Blue
07 - Purple



VIDEO
MINI-WECO LOOPING PLUGS
(LPM 75 06)

COLOR
06 - Blue



BNC EXTRACTION
TOOL 12"
(RTR1L)



BNC TO WECO
PATCH
(AD1W)



BNC TO MINI-WECO
PATCH
(ADMW12)

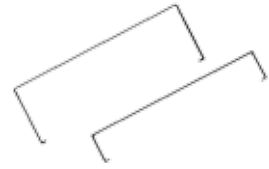

LACING
BARS



48-WIRE
NORMAL JUMPER
(NORMAL-48)



PUNCHDOWN HOUSINGS
AND PINS



PROGRAMMING
SHUNTS
Red - (382811-0)
White - (382811-9)



REPLACEMENT MATING
HARDWARE
(9603R)

PRODUCT NUMBERS

TOOLS

- CRIMP TOOL FOR EPIN (K2MA-01)
- EXTRACTION TOOL FOR EPIN (516-280-300)
- INSERTION TOOL FOR EPIN (516-280-400)
- COMPLETE E3 TOOLKIT (SBCTLKT01)
- PUNCHDOWN TOOL FOR ID (PT1LA)
- BNC EXTRACTION TOOL, 6" (RT1S)
- BNC EXTRACTION TOOL, 12" (RT1L)
- BNC EXTRACTION TOOL, 22" (RT1XL)
- BNC EXTRACTION TOOL, 12" (MINI-WECO) (RTMW1L)

ADAPTERS

- BNC TO WECO PATCH (AD1W)
- BNC TO MINI-WECO PATCH - SHORT (ADMW12)
- BNC TO MINI-WECO PATCH - LONG (ADMW12L)

CONNECTORS

- MALE 3 PIN CONNECTOR (E3M)
- MALE W/SCREW 90 PIN CONNECTOR (E90MS)
- 90 PIN HOOD (516-230-590)
- PIN (CRIMP TYPE) (EPIN)
- PUNCHDOWN HOUSING (RED) (K51002)
- PUNCHDOWN HOUSING (WHITE) (K51009)
- PUNCHDOWN HOUSING (BLACK) (K51000)
- PUNCHDOWN CONTACT (K514)

LACING BARS

- 6" DEEP LACING BAR (LB-17500)
- 3" DEEP LACING BAR (LB175-3)
- 19" WIDE RACK-RAIL LACING BAR (LB-19000)

STANDARD AUDIO SCHEMATICS



Standard Audio Patchbay Schematics

• Signal Ground
Last Update: 2/19/2016

<p>FULL-NORMALIZED BUSSED GND</p>	<p>FULL-NORMALIZED ISOLATED GND</p>	<p>FULL-NORMALIZED LOOPED GND</p>	<p>FULL-NORMALIZED SWITCHED GND</p>
<p>HALF-NORMALIZED BUSSED GND</p>	<p>HALF-NORMALIZED ISOLATED GND</p>	<p>HALF-NORMALIZED LOOPED GND</p>	<p>HALF-NORMALIZED SWITCHED GND</p>
<p>NON-NORMALIZED BUSSED GND</p>	<p>NON-NORMALIZED ISOLATED GND</p>	<p>NON-NORMALIZED LOOPED GND</p>	<p>NON-NORMALIZED SWITCHED GND</p>

600 Vest Elk Ave, Glendale, CA 91204 USA
 Tel: +1-818-500-8142 • Fax: +1-818-500-7062 • Email: cs@bitree.com • Web: www.bitree.com



NOTES

NOTES

P:1.818.500.8142 / BITTREE.COM / CS@BITTREE.COM

