



Equipment Supply Company



# Instruction Manual

22 Ton Air Hydraulic Service Jack

ESCO #10390



**WARNING:**

THIS PRODUCT, AS WELL AS ALL TIRE TOOLS, SHOULD NEVER BE USED BY PERSONS UNLESS THEY HAVE BEEN TRAINED PROPERLY ACCORDING TO OSHA REGULATIONS 29CFR 1910.177 ENTITLED "SERVICING SINGLE-PIECE & MULTIPIECE RIM WHEELS".

FOR THE SAFE USE OF THIS PRODUCT, PLEASE READ INSTRUCTIONS. FAILURE TO DO SO CAN LEAD TO A VOID IN WARRANTY OR SERIOUS INJURY. PLEASE USE THIS TOOL AND OTHER TIRE SERVICE TOOLS WITH THE UPMOST SAFETY PRECAUTIONS.

**CAUTION**

Before using the product, carefully read the instructions manual and all stickers and warnings noted on the product. This is necessary to avoid injury to the operator and damage to the product.

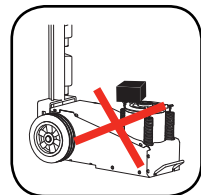
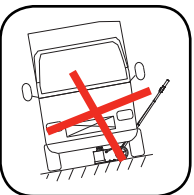
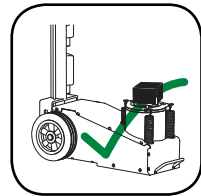
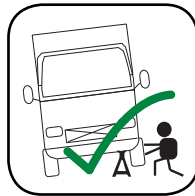
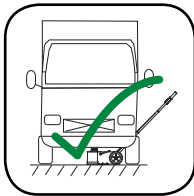
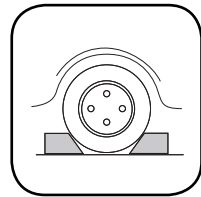
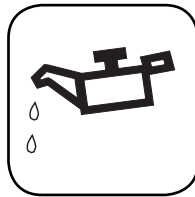

## Product Description

The ESCO Model #10390 22 Ton Air Hydraulic Service is a professional lifting jack designed for truck shops, service trucks, and other commercial vehicle lifting applications. 3-spring design lifting point for a more steady lifting of load and ergonomically designed air up/down function for everyday use. Full 90 degree handle positioning for ease of positioning.

## Product Specifications:

**Working Air Pressure:** 116-174 PSI (0.8-1.2Mpa)

**Minimum Height:** 8.5" (215mm)

**Lifting Height:** 5.5" (141mm)

**Extensions:** 0.75"- 2" - 4" (20mm - 50mm - 100mm)

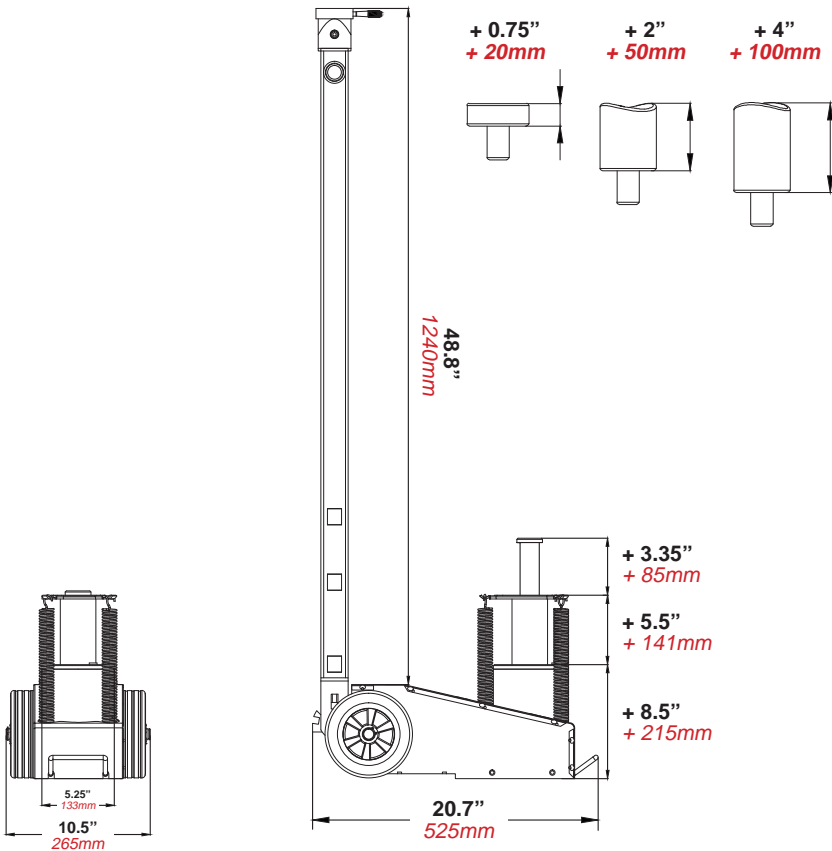



## POSITIONING THE HANDLE:

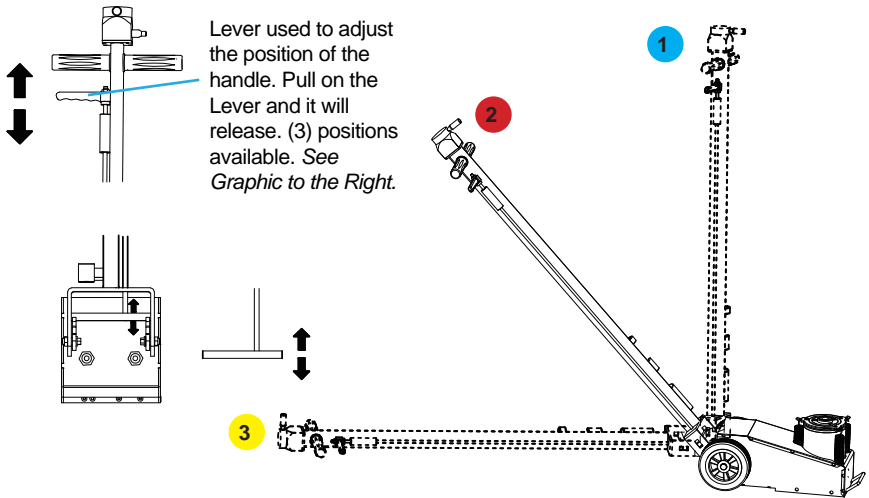

## ASCENDING & DESCENDING THE JACK:

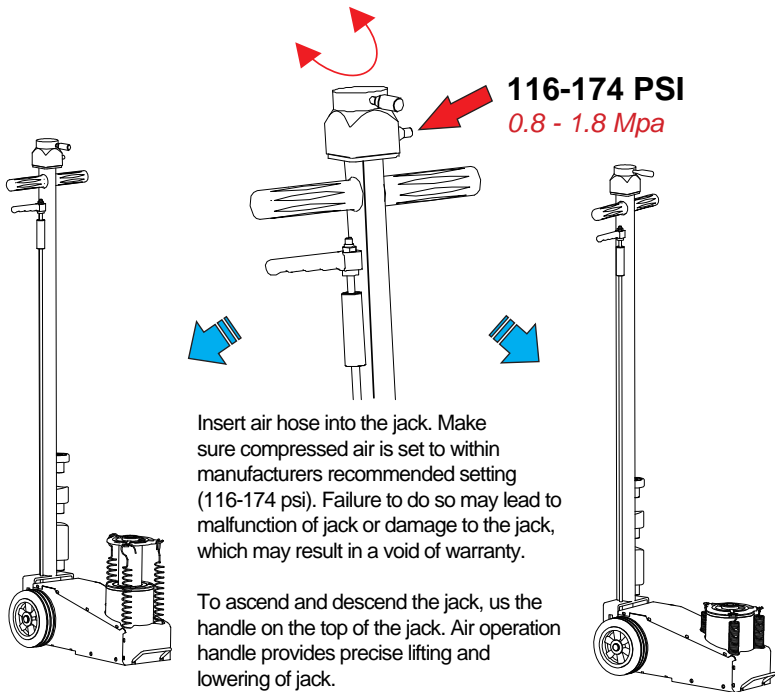



## PARTS BREAKDOWN - AIR MOTOR

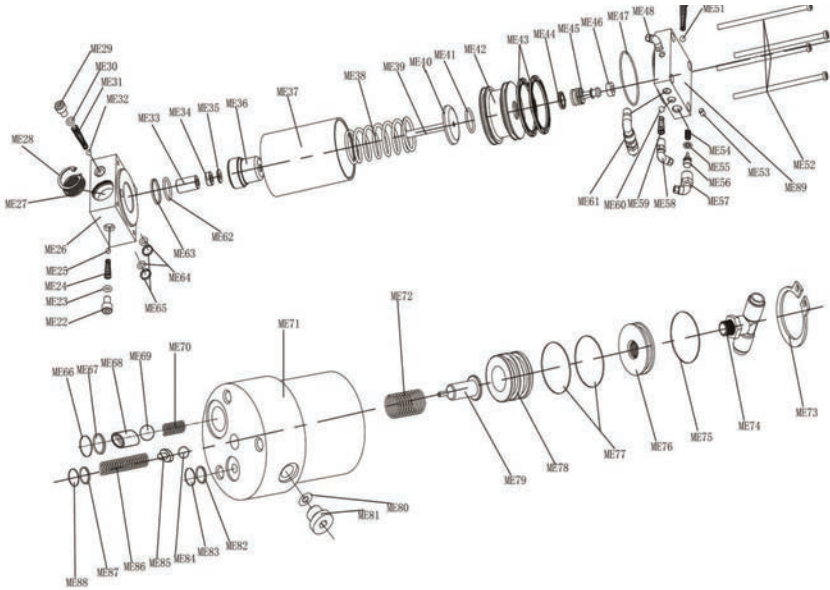

NO.:	Description
ME22	Screw Nut
ME23	O Ring
ME24	Spring
ME25	Steel Ball
ME26	Check Valve
ME27	Silencer Piece
ME28	Clamp
ME29	Screw Nut
ME30	O Ring
ME31	Spring
ME32	Steel Ball
ME33	Guide Bushing
ME34	Spacer
ME35	B3
ME36	Plunger Bushing
ME37	Air Cylinder
ME38	Spring
ME39	Plunger Rod
ME40	Plunger Cover
ME41	O Ring
ME42	Piston
ME43	PK Sealing
ME44	OE Sealing

NO.:	Description
ME45	Piston
ME46	Rubber Cap
ME47	O Ring
ME48	Tie In
ME49	Screw Nut
ME50	Spring
ME51	Rubber Ball
ME52	Screw
ME53	Screw Nut
ME54	Spring
ME55	O Ring
ME56	Piston
ME57	Tie In
ME58	Tie In
ME59	Spring
ME60	Rubber Ball
ME61	Tie In
ME62	O Ring
ME63	Locking Ring
ME64	O Ring
ME65	Locking Ring
ME66	O Ring
ME67	Locking Ring

NO.:	Description
ME68	Steel Ball Bulkhead
ME69	Steel Ball
ME70	Spring
ME71	Oil Drain Valve
ME72	Spring
ME73	Clamp
ME74	Tie In
ME75	O ring
ME76	End Cover
ME77	O ring
ME78	Oil Drain Piston
ME79	Oil Drain Bolt
ME80	O ring
ME81	Screw Nut
ME82	Locking Ring
ME83	O ring
ME84	Steel Ball
ME85	Screw Nut
ME86	Spring
ME87	Locking Ring
ME88	O ring
ME89	Air Inlet Base

**PARTS BREAKDOWN - FRAME ASSEMBLY & HANDLE**

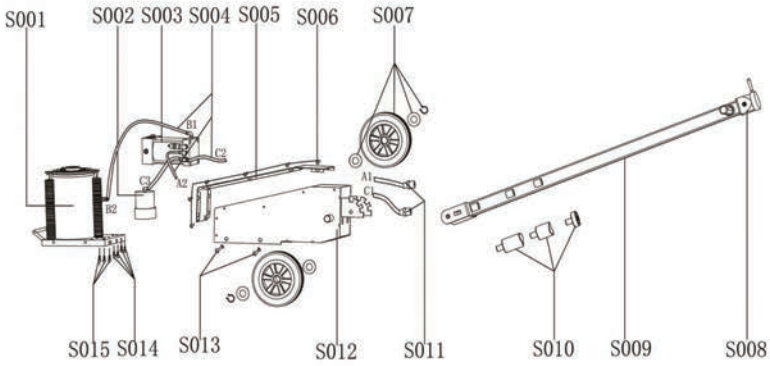

NO.	Description
S001	oil cylinder assy
S002	oil drain valve assy
S003	pump assy
S004	air hose
S005	tank cover
S006	screw
S007	wheel assy
S008	switch assy
S009	handle assy
S010	extension
S011	tie in
S012	tank
S013	screw
S014	screw
S015	screw



## OTHER PRODUCTS AVAILABLE THROUGH ESCO



**Tire Spreaders • Tire Inflation Cages • Torque Tools • Tire Inflators**



**Manual & Pneumatic Bead Breakers • Manual Tire Demounting Tools**



**Bead Holders • Air inflation Hoses • Pneumatic Torque • Balancing Beads**



**Air Hydraulic Bottle Jacks • Cribbing • Jack Support Plates**



**Wheel Weight Hammers • Valve Stem Pullers • Tire Lube • Wheel Attaching Parts**



*“Providing Quality Hydraulic Repair and Technical Support for All Your Hydraulic Product Needs”*

## **GUARANTEED 1 Day Turnaround Service.**

**Received by ESCO - Repaired in 24 Hours - Returned to You!**

- ▶ ESCO will pick up product for repair/warranty at your location.
- ▶ ESCO will guarantee Repair/Service for 30 days.
- ▶ ESCO has rental tools available
- ▶ ESCO repairs IMT, FEC, Stellar, Blackhawk, OTC, Power Team, Ame Int., & Enerpac hydraulic pumps, bead breaker, and cylinders.
- ▶ Authorized ESCO Repair & Warranty Centers Located through the US & Canada. For more information contact your ESCO sales representative.
- ▶ Technical Support Over the Phone Available by Calling 1-800-352-9852

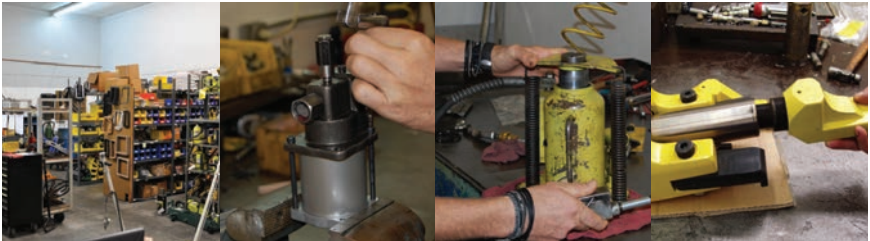

Prompt, reliable service after the sale is very important to ESCO. ESCO maintains an in-house repair facility in Brooksville, Florida. To insure that our customers have as little down-time as possible, we offer a 1 day turnaround service. Our factory repair service is equipped with all the tools and machinery needed to repair your equipment quickly and affordably. Our trained technicians are the best in the industry. Not only do we service our own products, but we also service our competitors' products.

In addition to ESCO's 30 years of providing quality repair service, ESCO has reached out and partnered with more than 50+ hydraulic repair facilities across the US & Canada, to deliver quality repair and timely return of products. Visit [www.esco.net](http://www.esco.net) or call 1.800.352.9852 to hear more about the newly added "Authorized ESCO Warranty & Repair Facilities" across the US.

If you have a bead breaker, ram, or hydraulic pump that needs repair, ESCO fixes your product with factory parts and guarantees the repair. In addition to servicing ESCO brand products, we also repair CP, IMT, Elrick, Branick, Goodyear, FEC, Ame Int., and Haltec lines of hydraulic bead breakers, rams, pumps, jacks, and many other hydraulic tire service equipment.



---

The Proper Tools To  
Keep Your Equipment  
**MOVING**



*ESCO - The Proper Tools to Keep Your Equipment Moving!*

---