

VMI 2500 Buffer™

User's Manual

Covers setup, getting to know your machine, alerts & warnings, repairing an optical disc, safety & cleaning, and FAQs

For models 2500 and 2550i

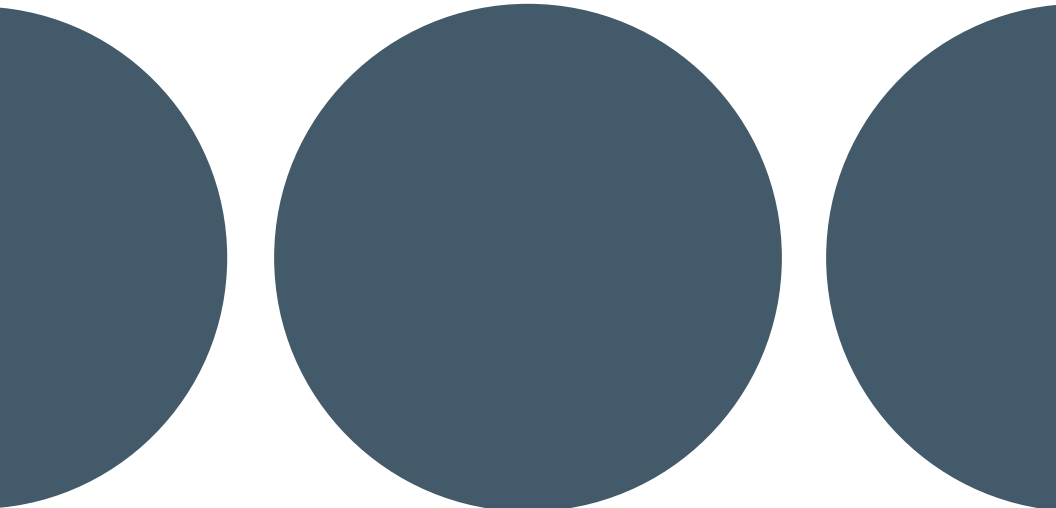

Light to Mid-Commercial Use
Maximum recommended daily use of 50 repair cycles

VenMill Industries, Inc
36 Town Forest Rd.
Oxford, MA 01540 USA
(866) 864-0210
Local: (508) 363-0415
Fax: (508) 363-0414
www.venmill.com

THANK YOU

For purchasing the VMI 2500/2550i Buffer™

This unit is intended to clean/repair the following discs: Blu-Ray, CD-ROMs, Music CDs, Data CDs, DVDs, HD-DVDs, Computer Discs, Game Discs, Books on disc, all recordable CDs and DVDs, double-sided discs, & 3 Inch Discs (only with adapter).

SAVE ALL PACKING MATERIALS. FAILURE TO USE PACKAGING DESIGNED FOR THIS UNIT MAY CAUSE DAMAGE TO THE UNIT AND WILL VOID WARRANTY. FOR MORE INFO CONTACT SUPPORT@VENMILL.COM.

© 2014 VenMill Industries, Inc. All rights reserved. Under the copyright laws, this manual may not be copied, in whole or in part, without the written consent of VenMill.

Every effort has been made to ensure that the information in this manual is accurate. VenMill is not responsible for printing or clerical errors.

Names and designs are trademarks of VenMill Industries, Inc. Artwork and Design © 2014 VenMill Industries, Inc. All Rights Reserved.

The maximum amount of repairs per bottle may vary based on cleaning cycle usage. See www.venmill.com for more information.

CAUTION: Units and consumables are designed for use in specific regions. Your warranty will be voided if you purchase the equipment and/or consumables outside of your designated region. Purchase only through Authorized Distributors found on our website at www.venmill.com. If uncertain, please contact sales@venmill.com.

READ BEFORE OPERATING EQUIPMENT

SECTION 1

Unpacking 1

SECTION 2

Getting to Know Your Machine 2

SECTION 3

Initial Setup 4

SECTION 4

Quick Start 5

SECTION 5

Modes of Operation 7

SECTION 6

Standard Maintenance 10

 Rubber Platter 10

 Buffing Wheels 11

 C2 Chip 12

 Machine Cleaning 13

 Splash Guard 13

 Cleaner Disc 14

 Rubber Platter 15

 Fan Filter 15

SECTION 7

Repacking 16

SECTION 8

VMI 2500/2500i Buffer™ FAQs 17

SECTION 8

Specifications 19

SAVE ALL PACKING MATERIALS. FAILURE TO USE PACKAGING DESIGNED FOR THIS UNIT WILL CAUSE DAMAGE TO THE UNIT AND WILL VOID WARRANTY.

Parts that need to be saved are as follows:

VMI 2500 Shipping Box | Internal Foams (2 foams total) | Outside Foam Left
Outside Foam Right | Protective Plastic Bag

There is a charge for replacement packing materials (plus S + H).

UNPACKING:

1. Open the Shipping Box.
2. Remove support documents / accessories.
3. Remove the VMI 2500 from the shipping box.
4. Remove the left and the right outside foams.
5. Take the VMI 2500 out of the plastic bag.
6. Remove any green tape located on the outside of the machine.

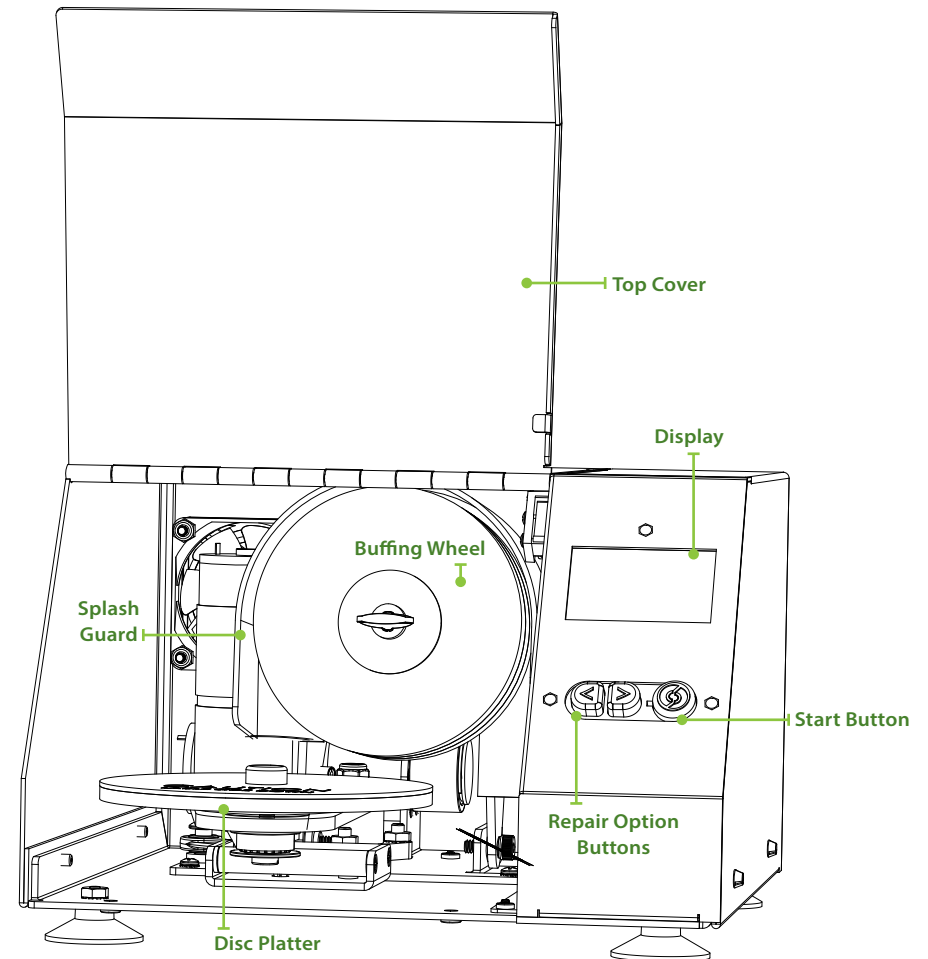
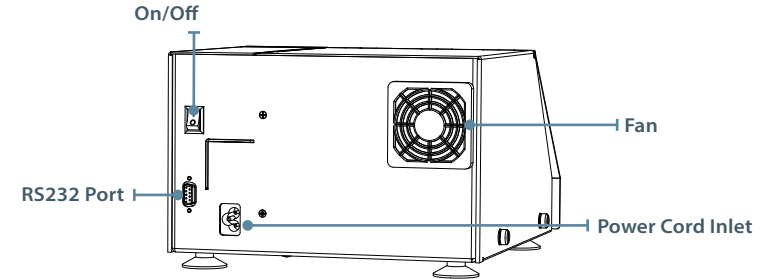
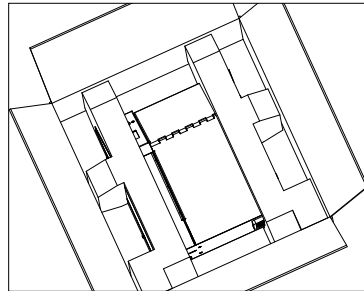

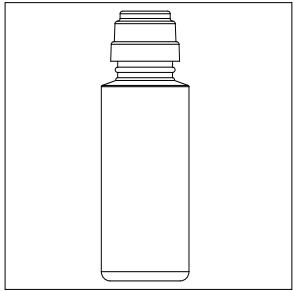

Buffing Solution:
250 minutes of operation per bottle

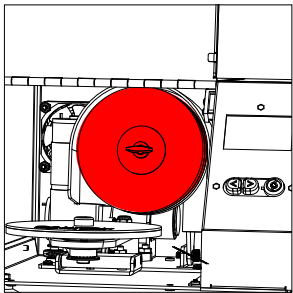

Buffing Wheels:
500 minutes of operation
(pre-installed)

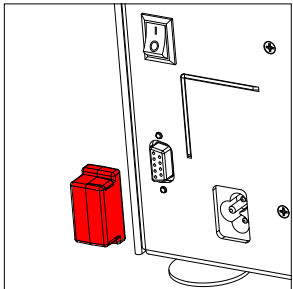

C-2 Chip:
500 minutes of operation
(pre-installed)

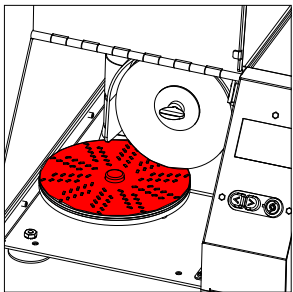

Cleaner Disc:
Use every 20 minutes

Initial Setup

Remove Internal Packing Material

1. Locate the two side panel thumbscrews and unscrew them.
2. Lift the side panel up and away from the machine.
3. Locate and remove foam #2, which is positioned in the front of the machine, under the buffing wheel.
4. Locate and remove foam #1, which is behind the main motor.
5. Reinstall the side panel and secure with the two thumb screws.

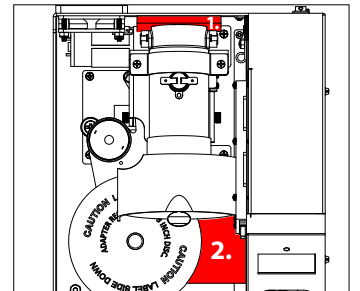
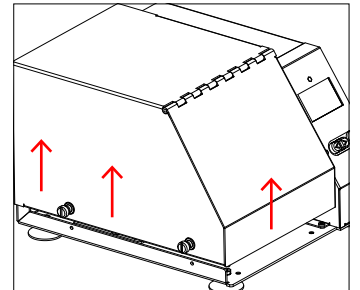
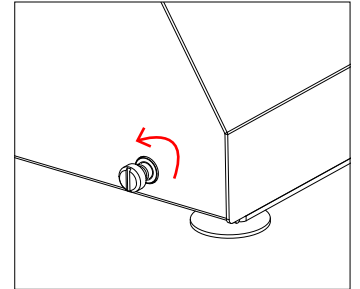

Install Power Cord

1. Insert the power cord into the power inlet on the back of the machine.
2. Take the other end of the power cord and plug it into a wall outlet.
3. Press the ON/OFF switch to the ON position.

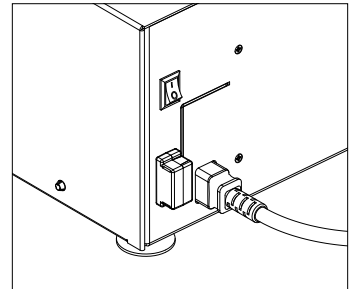

QUICK START - How to Use Your Machine

1. Turn on power to the unit.

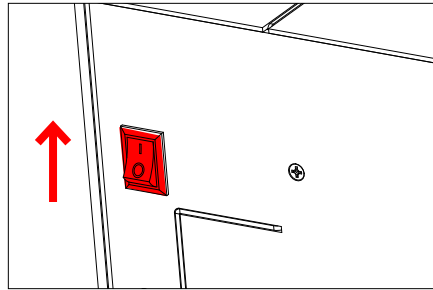

2. Select repair mode.

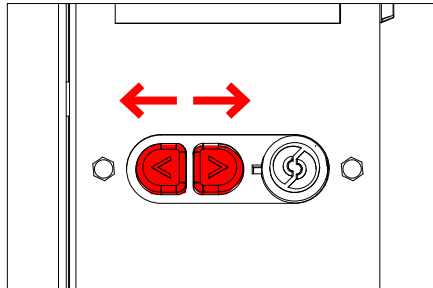

3. Spread the Buffing Solution evenly over the surface of the optical side of the disc.

Note: Avoid spreading solution on the clear plastic center ring of the disc, since the machine will not touch this area and solution will still be visible after the repair cycle.

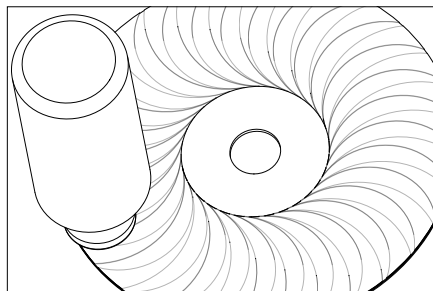

When not in use, place the cap back on the buffing solution bottle to keep the solution moist.

FAILURE TO USE CONSUMABLES DESIGNED FOR THIS UNIT WILL CAUSE DAMAGE TO BOTH UNIT AND DISC THEREBY VOIDING YOUR WARRANTY. FOR AUTHORIZED DISTRIBUTORS VISIT WWW.VENMILL.COM.

4. Insert DVD/CD/Blu-Ray with LABEL SIDE OF DISC FACING DOWN!

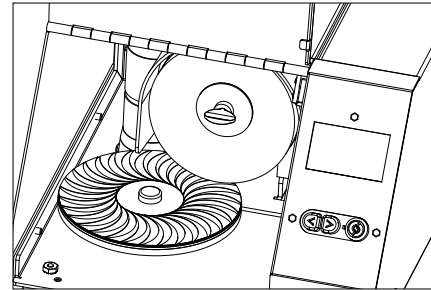

5. Close the Front Cover and press the Start Button.

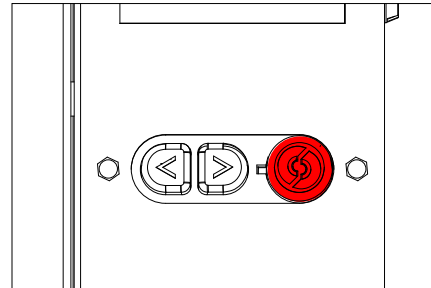

6. Remove repaired disc.

Important Note: If needed a disc can be run multiple times through the machine to achieve optimum repair quality.

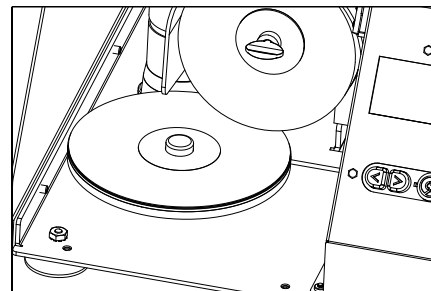

FAILURE TO USE CONSUMABLES DESIGNED FOR THIS UNIT WILL CAUSE DAMAGE TO BOTH UNIT AND DISC THEREBY VOIDING YOUR WARRANTY. FOR AUTHORIZED DISTRIBUTORS VISIT WWW.VENMILL.COM.

Modes of Operation

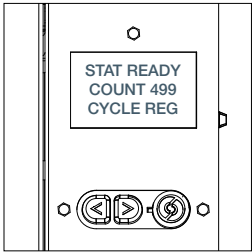

Regular

This option encompasses any of the following types of discs: CD-ROMs, Music CDs, Data CDs, DVDs, HD-DVDs, Computer Discs, Game Discs, Books on Disc, all recordable CDs and DVDs, Double Sided Discs, Blu-Ray, Wii U, and PS3.

Note: On this mode of operation, Blu-Ray and PS3 discs may only be cleaned. To “Repair” these types of discs, run them on the Deep Mode.

The VMI 2500 is preset to run on the “Regular” mode, as indicated by the Green LED light illuminated on the Start Button. The Cycle Mode is displayed on the LCD Screen in the “Main” Menu, on the bottom section. If the line reads: “Cycle REG”, then your unit is ready for a regular repair mode. This mode is set to run for 30 seconds.

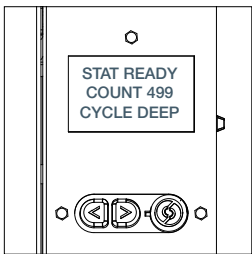

Deep

This option encompasses any of the following types of discs: CD-ROMs, Music CDs, Data CDs, DVDs, HD-DVDs, Computer Discs, Game Discs, Books on Disc, all recordable CDs and DVDs, Double Sided Discs, Blu-Ray, Wii U, and PS3.

The VMI 2500 is preset to run on the “Regular” mode.

To switch the machine over to the “Deep” mode of operation, press either one of the Scroll Buttons until Cycle Deep appears on display. Once the machine is set to the “Deep” mode, this will be indicated by a Blue LED light illuminated on the Start Button. Located on the LCD Screen in the “Main” Menu, on the bottom section, this is where the Cycle Mode is displayed. This mode is set to run for 1 minute.

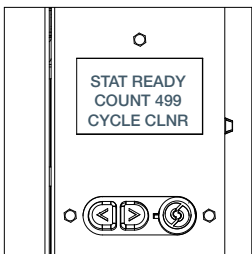

Cleaner

Over time, the Buffing Wheel will become encased with dried solution and plastic particles. Buffing Wheels left in this condition will effect the repair quality of the discs and in some extreme circumstances may cause damage to the discs themselves. For this reason the VMI 2500 has been designed to notify the Operator to clean the Buffing

Wheel. After about 20 minutes of machine operation, the Main Menu will display the message: “Cycle CLNR”, on the bottom section of the Cycle Mode line. The Start Button will also flash an illuminated Red LED light. At this point load the Cleaner Disc onto the rubber platter.

Note: Make sure the Cleaner Disc is loaded Label Side Down! Close the front cover and press the Start Button. Upon completion, the machine will reset back to the preset “Regular” mode and the Operator can now continue using the machine.

At certain times, the Operator may choose to run the “Cleaner” mode before the machine instructs the Operator to do so. In order to activate this mode of operation, press either one of the Scroll Buttons until cycle CLNR appears on display. Once the machine is set to the “Cleaner” mode, this will be indicated by a flashing Blue LED light illuminated on the Start Button. The Cycle Mode displayed on the bottom section of the Main Menu will read: “Cycle CLNR”. Proceed to insert the Cleaner Disc, close the front cover, and press the Start Button.

Emergency Stop

At anytime during the cycle you can stop a cycle prematurely, by pressing any button on the User Interface or by lifting open the front cover. Once the button is pressed or the front cover is lifted open, the cycle will stop and the Main Menu will display an error message: “Emergency Stop Wait”. An illuminated flashing Red LED light on the Start Button will also appear. Once the machine has realigned itself (**Note:** The Front Cover must be closed in order for the machine to realign itself), the machine will reset back to the last mode of operation that was selected. The Operator may now continue using the machine.

Replace Chip

The consumables (buffing wheel and buffing solution) have been designed to be replaced at the same time. The consumables originally provided with the VMI 2500 and the VMI 2500 Combo Packs are all rated for 500 minutes of operation. Each configuration is accompanied by a Consumable Counter Chip which informs the unit that the consumables have been replaced and installed. The amount of consumable usage time is displayed on the Count line located on the Main Menu. As the consumables deplete over time, the Count line display will count down in number according to the minutes left on the chip. Once the C2 Chip has reached 10%, the main menu will display the following information:

STAT READY
COUNT 050*
CYCLE REG

The asterisk (*) symbol will appear next to the count down time to indicate to the Operator that they should consider ordering more supplies for their unit. Another indication is provided for the Operator during the actual repair cycle itself. The Status line will read: "Low Chip" and the Start button will flash from Blue to Green while the cycle is in process.

STAT EMPTY
COUNT 000
CYCLE RC

Once the C2 Chip has reached 0%, the main menu will display the following information:

At this point, the machine will not perform any other operations until a new C2 Chip is installed.

To replace the C2 Chip:

1. Locate the used C2 Chip inserted on the back of the machine.
2. Remove the used C2 Chip. Once removed, an exposed RS232 port will become visible.
3. Install a new C2 Chip into the RS232 port. (See photo on p. 3)

WARNING: CONSUMABLE COUNTER CHIPS ARE DESIGNED SPECIFICALLY PER COUNTRY CODE! A USA REGIONED C2 CHIP WILL NOT BE COMPATIBLE WITH A EUROPEAN OR AUSTRALIAN CODED VMI 2550i AND VISA VERSA.

STAT READY
COUNT 500
CYCLE REG

Once a new C2 Chip has been installed, the main menu will display the following information:

At this point the machine will resume operation. **Note:** There is no need to reset the counter. Once the new C2 Chip has been installed all counts are reset.

ERROR MESSAGES:

ES003:Magnetic Switch Sensor is not detecting that the Platter is in the home position.

EC004:Lift Cam Switch is not detecting that the Lift Cam has reset back to the home position.

EMC006:The machine is not detecting the proper amount of amperage on the main motor.

RC:Replace All Consumables

Emergency Stop:Emergency Shutdown Mode

Standard Maintenance

RUBBER PLATTER

When should I replace my rubber platter?

There is no specific timeframe for how long a Rubber Platter will last. Depending on how the machine is used and maintained, the Rubber Platter could last one day or one year. If the disc can no longer sit flat on the Rubber Platter, or the lettering on the surface is no longer visible, then the Rubber Platter should be replaced. If there are any nicks, gouges, edges that are lifted, or tears – the Rubber Platter should be replaced.

How to replace the Rubber Platter:

1. Turn off power to the unit!
2. Locate the two side panel thumbscrews and unscrew them.
3. Lift side panel up and away from the machine.
4. Locate the Rubber Platter.
5. Peel old Rubber Platter off of the platen. *Note: A razor blade or a scraper can be used to do this.*
6. Remove the white backing from the new Rubber Platter.
7. Center and place the new Rubber Platter on the platen.
8. Make sure the Rubber Platter is fully seated on the platen.
9. Install the side panel and secure with the two thumbscrews.
10. Turn on power.

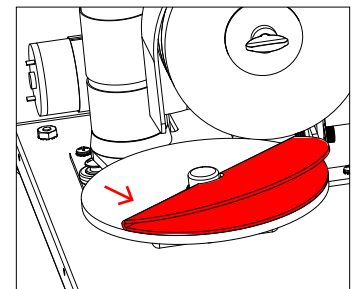
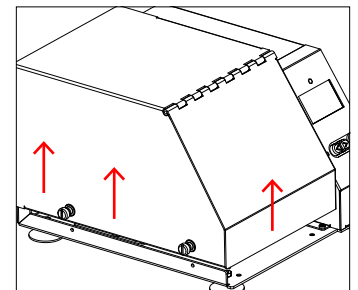
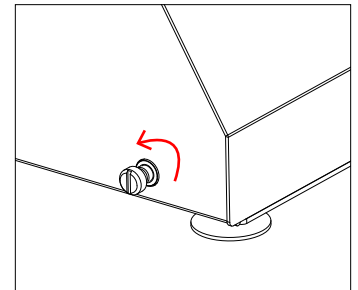
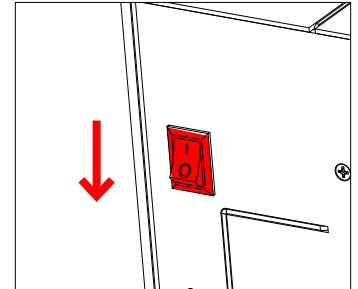

BUFFING WHEELS**How to replace the Buffing Wheels:**

1. Turn off power to the unit.
2. Locate the two side panel thumbscrews and unscrew them. Lift side panel up and away from the machine.
3. Locate the Splash Guard which sits on top of the main motor and above the Buffing Wheel.
4. Pull up on the Splash Guard until it releases from the main motor.
Note: The Splash Guard is a snap fitted piece.
5. Located in front of the Buffing Wheel is a washer and a Spade style screw, which holds the Buffing Wheel to the spindle. Hold the Buffing Wheel with one hand and turn the Spade Screw counter clockwise with the other.
6. Remove the screw and the washer from the spindle and pull off the old Buffing Wheel.
7. Install the new Buffing Wheel. Insert the washer and tighten the screw.
8. Reinstall the Splash Guard by snapping it onto the top of the main motor.
Note: Pull the Splash Guard forward until it snaps into place a second time.
9. Install the side panel and secure with the two thumbscrews.
10. Turn on power.

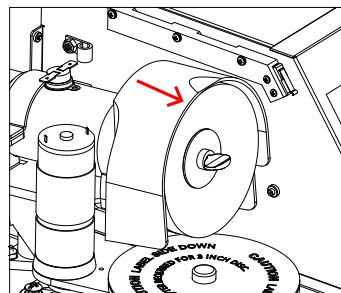
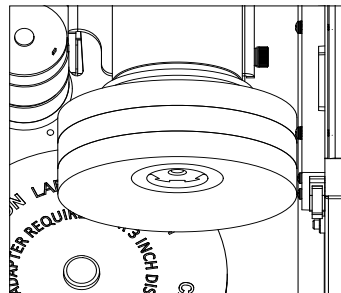
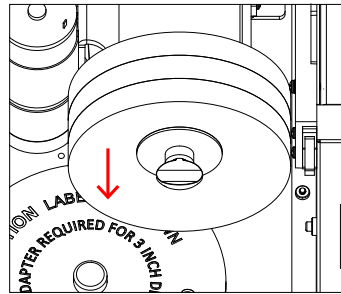
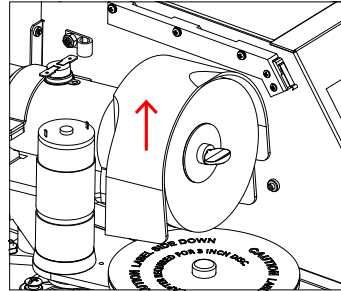
**C2 CHIP****When should I replace my C2 Chip?**

Each C2 Chip is programmed for a total of 500 minutes of operation. The amount of usage on this chip will be displayed on the front LCD Screen. On the "Main Menu", in the middle of the screen, this is where the total Chip count is displayed. This "Count" will decrease in amount according to the minutes left on the C2 Chip. When the count drops to 10%, an asterisk (*) will appear next to the Count display. This is a reminder to reorder supplies. At this point, while a cycle is running, the "Start" button will flash from Green to Blue. The error message: "Low Chip" will appear on the main menu. Once the chip is depleted, STAT EMPTY will appear on the main menu. The machining will not perform any operations until a new C2 Chip is installed. There is no need to reset the counter. Once the new C2 Chip has been installed all counts are reset.

How do I replace my C2 Chip?

1. Turn the machine around, so that the back of the unit is facing you.
2. Important - Turn off power to the unit.
3. Locate the C2 Chip.
4. Pull the chip out of the RS232 port.
5. Install the new C2 Chip into the RS232 port.
6. Turn on power and the machine will automatically reset the counter.

FAILURE TO USE CONSUMABLES DESIGNED FOR THIS UNIT WILL CAUSE DAMAGE TO BOTH UNIT AND DISC THEREBY VOIDING YOUR WARRANTY. FOR AUTHORIZED DISTRIBUTORS VISIT WWW.VENMILL.COM.

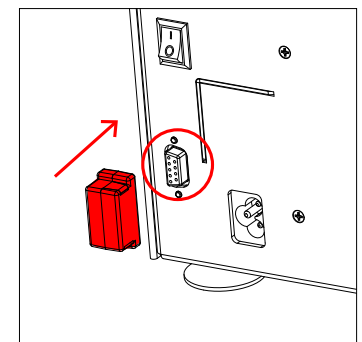

How to clean out the machine.

Recommendation: Clean the machine weekly.

1. Turn off power to the unit!
2. Locate the two side panel thumbscrews and unscrew them.
3. Lift side panel up and away from the machine.
4. Remove any dust or debris from the machine. **Note: Use canned air, a vacuum, or even by hand.**
5. With a paper towel or cloth, wipe off any buffing solution residue left on the side panel or internal walls.
6. Install the side panel and secure the two thumbscrews.
7. Turn on power.

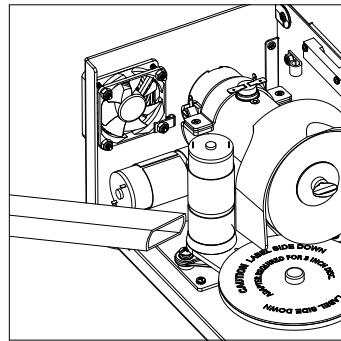
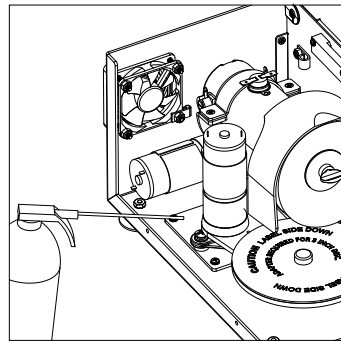
**How to clean the Splash Guard:**

Recommendation: Clean the Splash Guard weekly, when the rest of the machine is being cleaned out.

1. **IMPORTANT:** Turn off power to the unit.
2. Locate the two side panel thumbscrews and unscrew them.
3. Lift side panel up and away from the machine.
4. Locate the Splash Guard which sits on top of the main motor and above the Buffing Wheel.

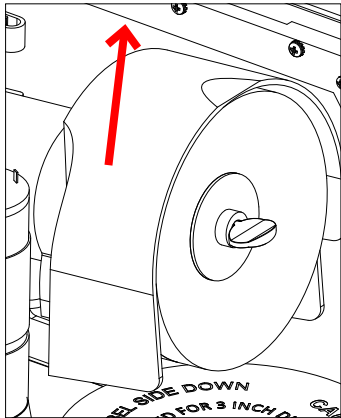

5. Pull up on the Splash Guard until it releases from the main motor. **Note: The Splash Guard is a snap fitted piece.**
6. Run the Splash Guard under warm water. Wipe away any leftover buffing solution residue with a paper towel or cloth.
7. Reinstall the Splash Guard by snapping it onto the top of the main motor. **Note: Pull the Splash Guard forward until it snaps into place a second time.**
8. Install the side panel and secure the two thumbscrews.
9. Turn on power.

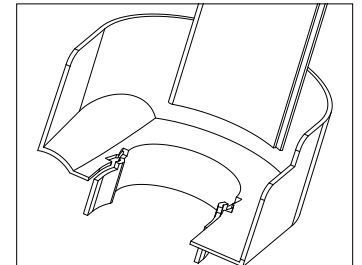
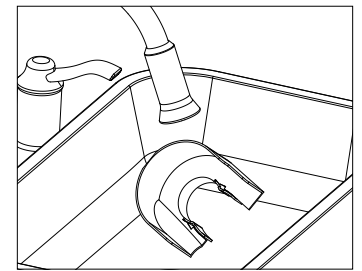
**How to clean the Cleaner Disc:**

The Cleaner Disc must be cleaned on a regular basis. You can identify that the Cleaner Disc needs to be cleaned by seeing a heavy buildup on the surface.

1. Use a "Glass Cleaner" (such as Windex). Spray it on the surface of the Cleaner Disc and let it sit for a minute.
2. Using a paper towel, wipe the buildup off the Cleaner Disc. Start from the center and work your way out.
3. Make sure the Cleaner Disc is dry before use.

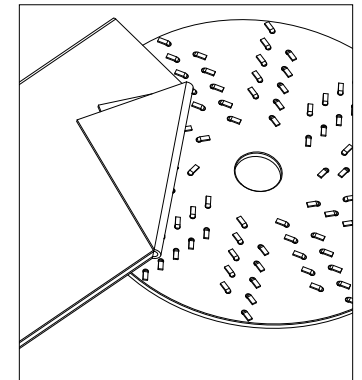

Alternative option: use a plastic bristle brush to scrub the surface.

FAILURE TO USE CONSUMABLES DESIGNED FOR THIS UNIT WILL CAUSE DAMAGE TO BOTH UNIT AND DISC THEREBY VOIDING YOUR WARRANTY. FOR AUTHORIZED DISTRIBUTORS VISIT WWW.VENMILL.COM.

How to clean the Rubber Platter and why:

From time to time the Rubber Platter may become dirty. When this happens, dust particles can become entrapped on the top surface of the platter. This causes the surface to become slick. When the Rubber Platter is slick, discs tend to slip on the surface. This slipping could cause a disc to break.

1. Spray the Rubber Platter with a glass cleaner (such as Windex) and let it sit for about one minute.
2. Wipe the rubber platter dry with a paper towel.
3. If slippage continues, replace the Rubber Platter.

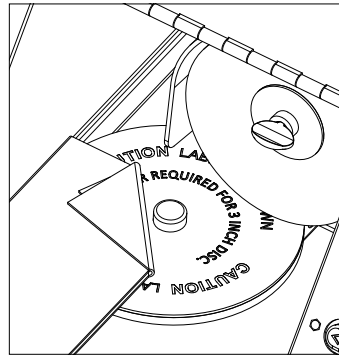
**How to clean the Fan Filter:**

After 60 minutes of operation the machine will display "Filter CLNR" message. This message indicates that it is time to clean out the fan filter. It is important to keep constant airflow in the machine.

1. Locate the fan guard on the back of the machine and pull off plastic guard.
2. Remove the filter and blow out collected debris.
3. Reinstall filter and guard.
4. Push any button on the user interface to continue with normal operation.

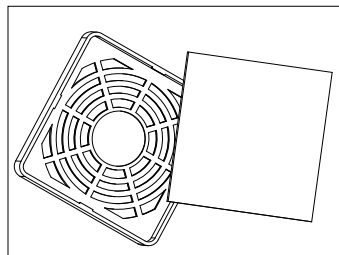
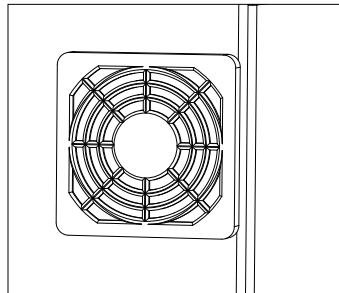
**REPACKING:**

1. Turn off power to the machine.
2. Remove the power cord from the back of the unit.
3. Locate the two side panel thumbscrews and unscrew them.
4. Lift the side panel up and away from the machine.
5. Locate the Main Motor. Push down on the top front of the Main Motor, so that the back end lifts up slightly.
6. Insert foam # 1 behind the back of the Main Motor, against the back wall of the machine.
7. Locate the Platter on the front of the machine.
8. Insert foam # 2 to the right of the Platter and below the Buffing Wheel.
9. Install the side panel secure the two thumbscrews.
10. Place the machine into the Protective Plastic Bag.
11. Place the machine into the left and the right outside foams.
12. Place VMI 2500 that has been encased within the outside foams and protective plastic bag, into the Shipping Box.
13. Insert anything else that has been required by the Technical Support Department.
14. Close and tape box shut.
15. Write provided RMA number on the outside of the Shipping Box.

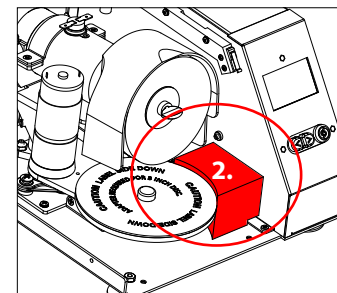
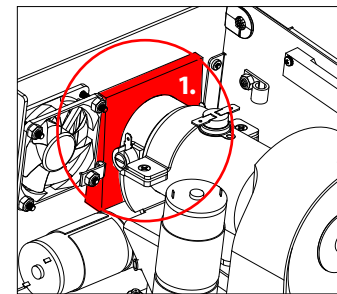
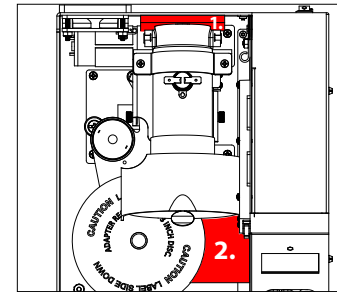

FAILURE TO USE CONSUMABLES DESIGNED FOR THIS UNIT WILL CAUSE DAMAGE TO BOTH UNIT AND DISC THEREBY VOIDING YOUR WARRANTY. FOR AUTHORIZED DISTRIBUTORS VISIT WWW.VENMILL.COM.

Note: In order to send a machine in for servicing, a customer must call Technical Support first (866-864-0210) to troubleshoot the unit. If an authorized technician deems that the machine is in need of servicing, they will provide the customer with an RMA form to fill out. Any machine sent in without authorization may be denied delivery and will be returned to the customer at their expense.

If you have any questions that are not covered here, please refer to our website, www.venmill.com.

How often should I use my VMI 2500 Cleaner Discs?

The VMI 2500 will indicate when it is time to run a cleaning cycle for the buffing wheel. After 20 minutes of operation, the Main Menu will display the message: "Cycle CLNR", on the bottom section of the Cycle Mode line. The Start Button will also flash an illuminated Red LED light. At this point load the Cleaner Disc onto the rubber platter. Note: Make sure the Cleaner Disc is loaded Label Side Down! Close the front cover and press the Start Button. Upon completion, the machine will reset back to the preset "Regular" mode and the machine will continue with normal operation.

VenMill highly recommends that the Cleaner Disc be run as the last cycle of the day, regardless of when the Cleaner Disc was last used!

Why is the VMI 2500 Cleaner Disc important?

During the buffing process your Buffing Wheel removes oil, dirt, buffing solution, and a small layer of plastic from the surface of your disc. This build up, over time, will cause your Buffing Wheel to become dirty and stiff. This can result in an inferior repair and a decrease in your Buffing Wheel life expectancy. The VMI 2500 Cleaner Disc cleans and softens your Buffing Wheel.

When should I clean my VMI 2500 Cleaner Disc?

VenMill does not recommend going

past 5 uses without cleaning your VMI 2500 Cleaner Disc. If a build up is noticed on the Cleaner Disc, feel free to clean it at anytime.

Can I clean a 3 inch disc?

Yes, but you will need to obtain a special 3 inch adapter from VenMill Industries.

Can I run a 3 inch disc without an adapter?

No! This will damage your 3 inch disc and your rubber platter.

Why is the Buffing Solution important?

The Buffing Solution is a unique formula, which accomplishes two very important tasks: prevents static charges from developing during the buffing process and helps in the repair process rendering the disc optically clear.

Do I have to use the Buffing Solution on my discs?

Yes! Besides the inferior repair results, the static charge produced during the buffing process can create unpredictable errors in the unit and may cause damage.

The center of my disc still has Buffing Solution on it after a repair.

The Buffing Wheel never touches the innermost clear plastic center of the disc. If there is Buffing Solution in the center of the disc, it can be wiped away. To prevent this from happening, only use the Buffing Solution on the optical surface of the disc.

Can I repair a Double Sided disc?

Yes!

Can I repair a Blu-ray disc?

Yes! Use the Deep Cycle.

Can I repair a disc that is warped or cracked?

No! This may result in further damage to the media and/or your unit.

How long will a bottle of Buffing Solution last?

If used properly, one bottle of Buffing Solution should last approximately 250 minutes of machine operation. You may order consumables through VenMill directly at www.venmill.com or through our distributors located on our website under the Distributors' tab. If you have any questions, please contact us at 800-928-0090 / 866-864-0210 Intl. or email sales@venmill.com.

How much Buffing Solution must I use?

VenMill suggests that the entire optical surface of the disc be covered with the Buffing Solution. This will ensure optimal repair capabilities. To achieve this, place one dab North, East, South, West and then spread around the disc.

Can I run my unit over 500 minutes without replacing the C2 Chip?

No! Once the C2 Chip is depleted the unit will not allow for any more cycles to be run. Once a new C2 Chip has been installed, the machine will continue with normal operation.

Why is my Buffing Wheel discolored?

This indicates that the Cleaner Disc has not been run enough or that the Cleaner Disc needs to be cleaned. You may need to use the Cleaner Disc

several times to improve the condition of the Buffing Wheel. If you do not see any improvement you will need to change your wheel.

My machine lost power and is not turning back on!

The VMI 2500 has been equipped with an internal thermostat to ensure that the machine does not overheat and cause damage to your machine or your digital media. Once the internal temperature reaches approximately 130 degrees (Fahrenheit) the thermostat will turn off power to the machine so that it can cool down. The machine may need to idle for approx. 15 minutes, before the power will turn back on. To help cool the machine down faster, open the Front Cover. If the power has not turned back on within an hour please contact Technical Support at 800-928-0090.

My LCD panel just "Blue Screened" and the entire machine restarted!

If the Power Cord is not fully inserted into the back of the machine, this can cause a short, which will restart the firmware program on the logic board. Remove the Power Cord from the back of the machine and then reinstall the Power Cord by pushing in as far as it can go.

How can I tell how many total cycles have run on my VMI 2500?

Turn on the unit and open the front cover. Press the repair button and the display will show how many total cycles you have run. Totals are broken down by regular, deep, and clean cycles.

Disconnect unit from supply circuit before opening
Déconnecter du circuit d'alimentation avant d'ouvrir

WARNING AND CAUTIONS

You are cautioned that any changes or modifications not expressly approved in this manual could void your warranty.

Operating room temperature is 72°F(22°C) +/- 12°F(7°C)

To prevent fire or shock hazard, do not expose the unit to rain or moisture.

If you have any questions about this product, you may call VenMill Industries Customer Service at 800.928.0090 USA, or 866.864.0210 N. Amer.



CAUTION: This symbol is intended to alert the user to the possible presence of uninsulated "dangerous voltage" within the product's enclosure that may be of sufficient magnitude to constitute a risk of electric shock to persons.



EMERGENCY STOP: Pushing either the "Stop" or "Open" button on the front panel during the buffing cycle will stop the unit and reset the firmware. A series of three beeps will be heard and the tray may open. You may resume normal operation.

SPECIFICATIONS

Unit operates on 220/240V 50 Hz AC power 10 amp max

Safety features:

- Disconnectable power cord
 - ON/OFF switch
 - Safety interlock when interior is exposed
 - Process controlled to prevent operation when front cover is the opened position
 - Thermal circuit breaker will shut off power if internal temperature exceeds 130° F (54° C)
 - Fan operates when the unit is running
 - Emergency stop with any buttons or opening of the front cover
-
- Weight: 21lbs
 - Dimension: 11.25 in x 10.25 in x 6.75 in
 - Power: Safe DC Power
 - Part Number: PNV2500
 - Supplies used with unit: Buffing pads, and Repair Solutions.
 - Warranty: 1 Year Limited
 - Process: Simple-to-use, one-touch

FOR SUPPORT INFORMATION

www.venmill.com

or

508-363-0410

866-864-0210 TOLL FREE

FOR SERVICE OUTSIDE OF NORTH AMERICA
PLEASE CALL YOUR REGIONAL DISTRIBUTOR

If you are not sure who your regional distributor
is please contact sales@venmill.com or visit our
Distributors page at www.venmill.com

MAILING ADDRESS:

VenMill Industries, Inc.
36 Town Forest Rd.
Oxford, MA 01540

REORDER INFORMATION FOR

CONSUMABLES USED WITH THE VMI 2500 (ONLY FOR THE USA)

VMI Combo Pack (1 wheel, 2 bottles, and 1 C2 chip).....**PN2501**
VMI Rubber Platter.....**PN2012G**
VMI Cleaner Disc.....**PN2519**