



INSTALLATION INSTRUCTIONS

MECHRON

2450

SAFETY INSTRUCTIONS

Warning: Failure to heed all safety and operating instructions and warnings regarding use of this product can result in serious bodily injury.

READ PROPERLY COMPLETE ASSEMBLY INSTRUCTIONS BEFORE STARTING OF ASSEMBLY

Install all parts indicated in assembly instructions. Failure to fully assemble product before use could result in personal injury.

Assembly of product requires use of hand or power tools. If you are not experienced in using these types of tools, have product dealer do the install for you.

Some parts contain sharp edges, wear protective gloves if necessary. Always keep your assembly area clean, uncluttered and well lit.

Keep visitors and children a safe distance away from the assembly area. Visitors should wear the same safety equipment described under.

Never operate your UTV with the cab doors open. Failure to properly latch the doors before moving the vehicle could result in serious injury.

Dress for safety. DO NOT wear loose clothing, gloves, neckties or jewelry if using power tools to assemble this product. Insert all nut covers after you finish installation.

Never drive your UTV with the cab front window in open position.

Failure of improperly latched/locked front window before driving the vehicle could result in serious injury.

MAINTANCE AND CLEANING

To clean polycarbonate surface use soapy water solution or other subtle means.

Dirt and dust wash by gently water stream and swipe only with wet or damp means in the direction from top to bottom.

The recommended frequency of cleaning of polycarbonate part is about 1 time per month or according to the actual degree of pollution.

Do not use detergents that could scratch the surface plates. (abrasives, harsh fabrics, etc.)

Do not use solvents or alkaline detergents or cleaners with ammonia (ammonium hydroxide).

Do not remove the impurities from the surface of the razor blades or other sharp items.

Do not clean cabine, when the polycarbonate plates are heated by the sun.

Do not use the squeegee, it could be scratched surface plates.

Do not clean the water current strength greater than 50 bar (WAP)

The manufacturer is not responsible for scratching the surface in case of failure to comply with the above instructions.

All bolted connections of cab must be by user at regular intervals checked and tightened.

HEATER

Open the hoodie and place heater to the under hood space.

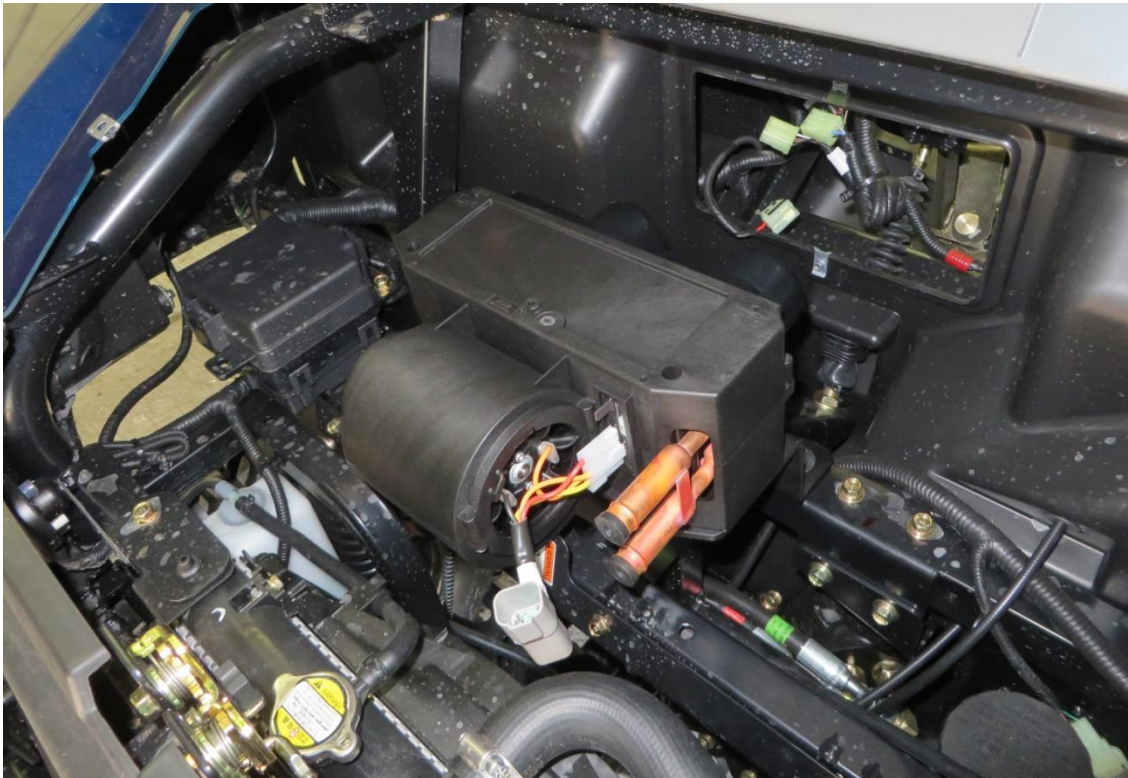

Attach the heater holder with included fixing assembly. Use original UTV frame hole.



Attach the heater holder with included fixing assembly on the other side.
Use original UTV frame hole.

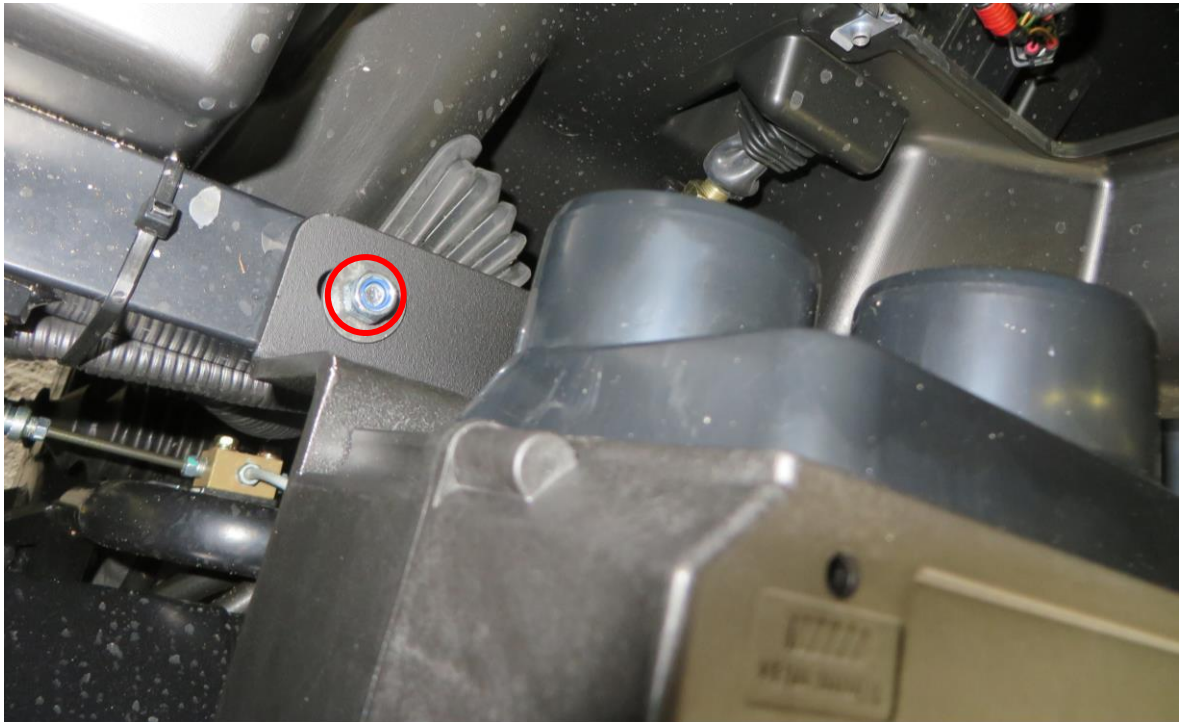

Attach the included water hose (longer) on the bleeding valve with included tightening strap.



5

Detailed view of the bleeding valve with connected water hose.

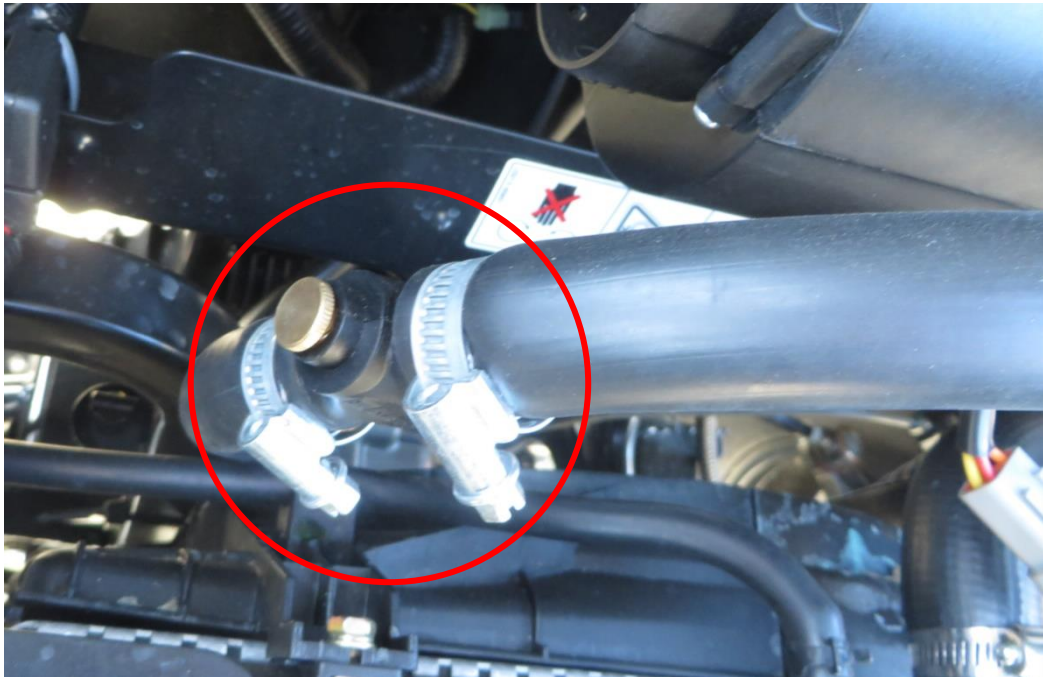

Route the water hose with the water pump behind the UTV cooling system radiator to the front left wheel.



6

Attach the included water hose (shorter) on the water pump with included tightening strap.



Get under the vehicle and find the original cooling system water hose with coupling and tightening straps.

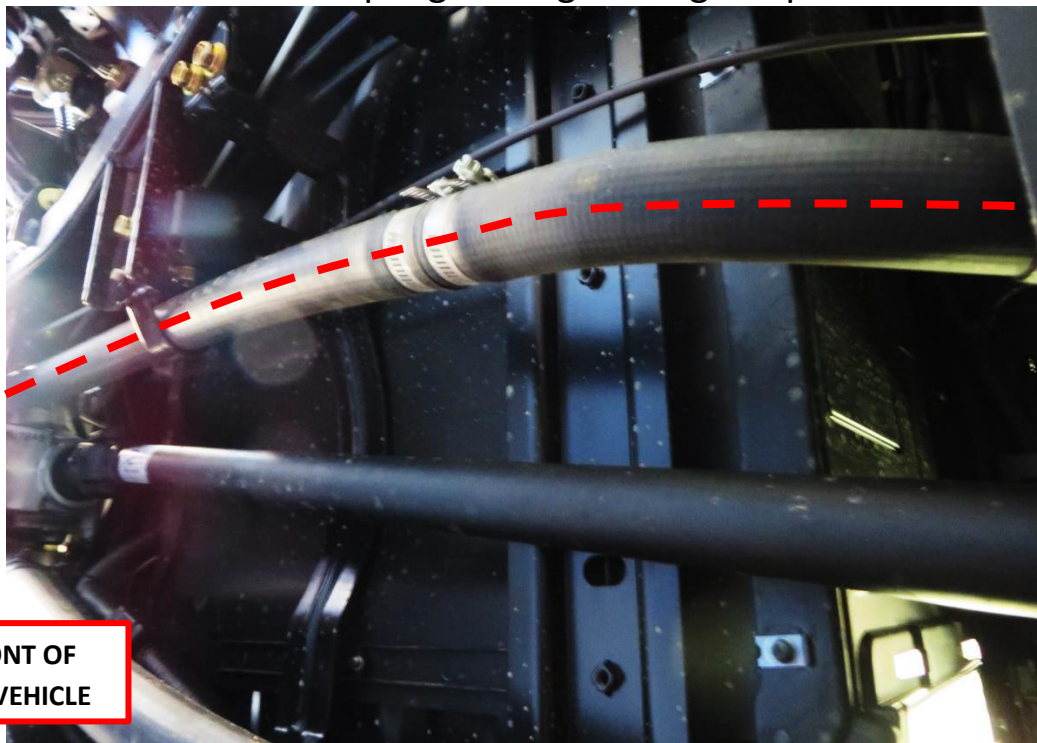

**FRONT OF
THE VEHICLE**

Secure the original cooling system water hose with clamps on both sides of the coupling. Loosen the tightening straps and remove the coupling.



Replace the original coupling with included “Y” coupling. To the “Y” coupling connect also the hot water hose from the water pump.



Secure the original cooling system water hose with the clamps.

FRONT OF
THE VEHICLE



Cut the original cooling system water hose between the clamps.

FRONT OF
THE VEHICLE



Mount the “Y” coupling onto the heater water hose from the bleeding valve.



Install the “Y” coupling between the cutted hose and attach with included tightening straps.

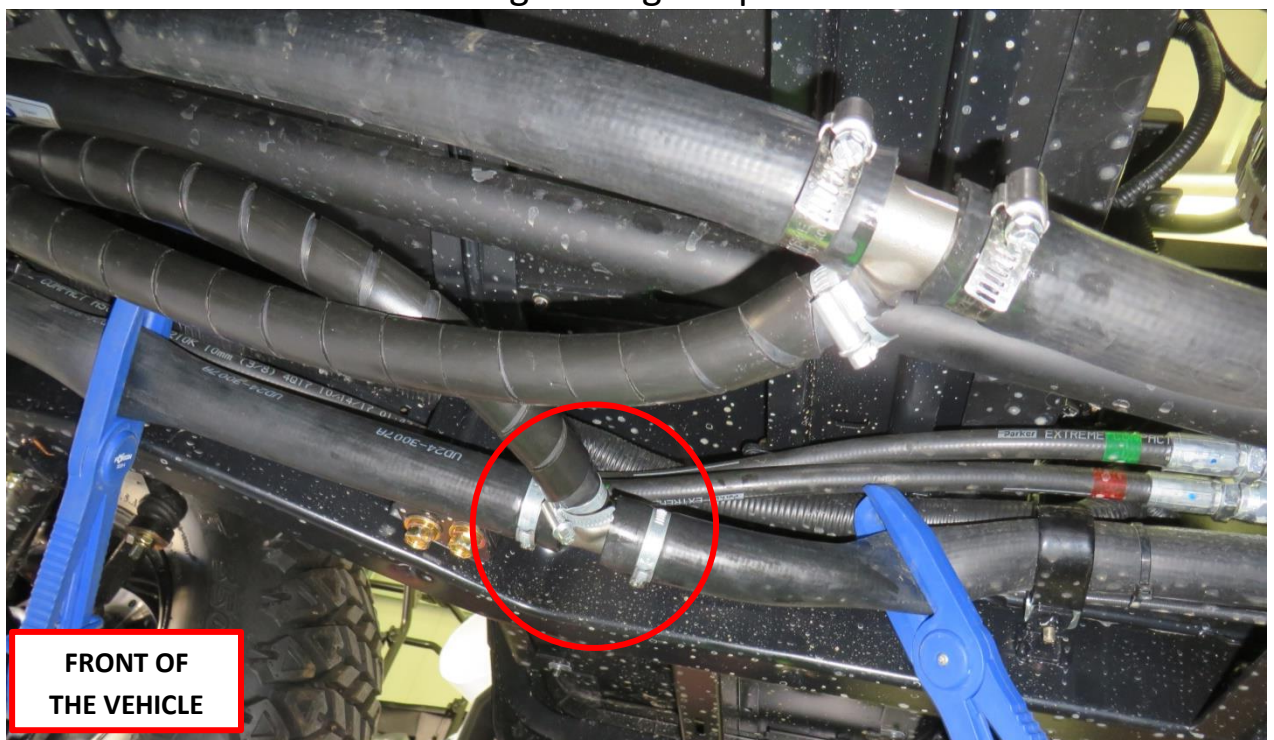

10

Attach the hoses with included plastic tightening ties.

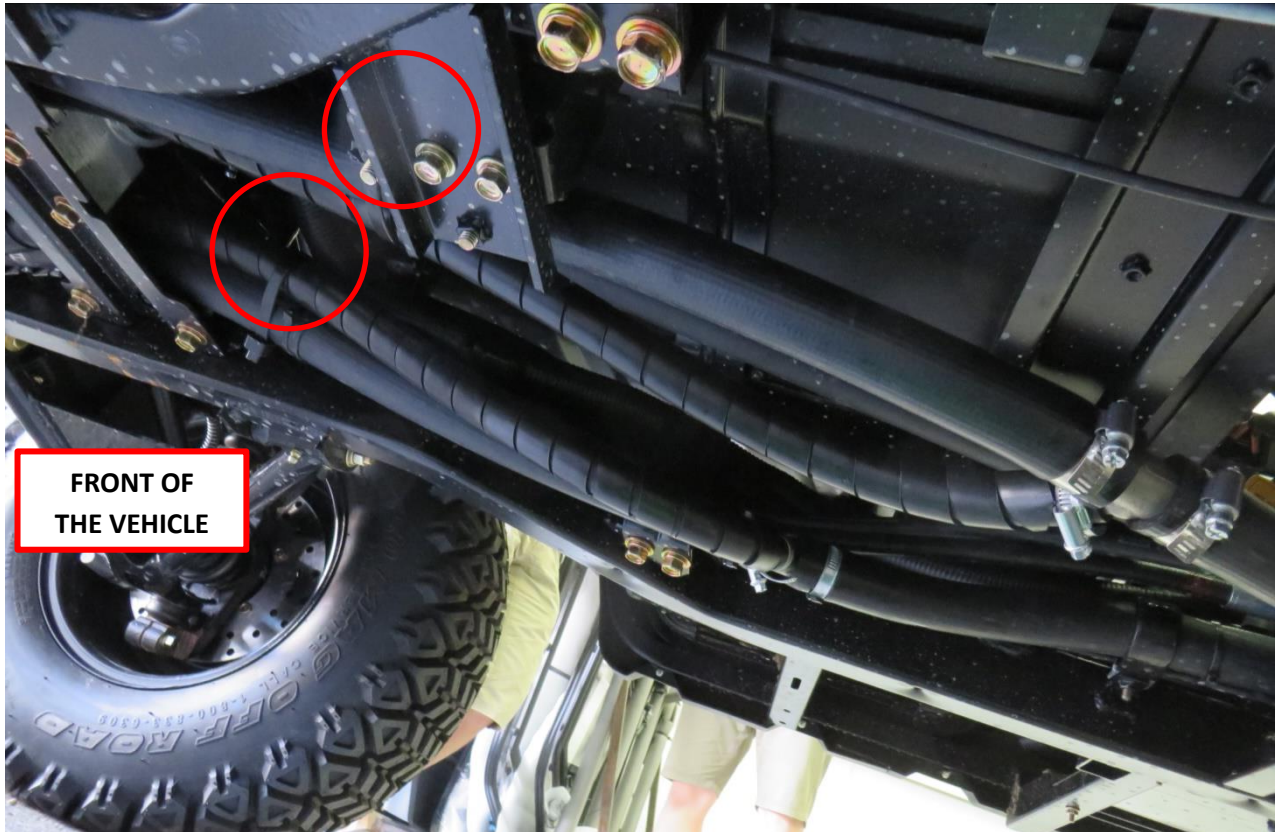

Drill two holes \varnothing 55 mm into the dashboard for the heater air vents.



Heater air vents holes vertical position.

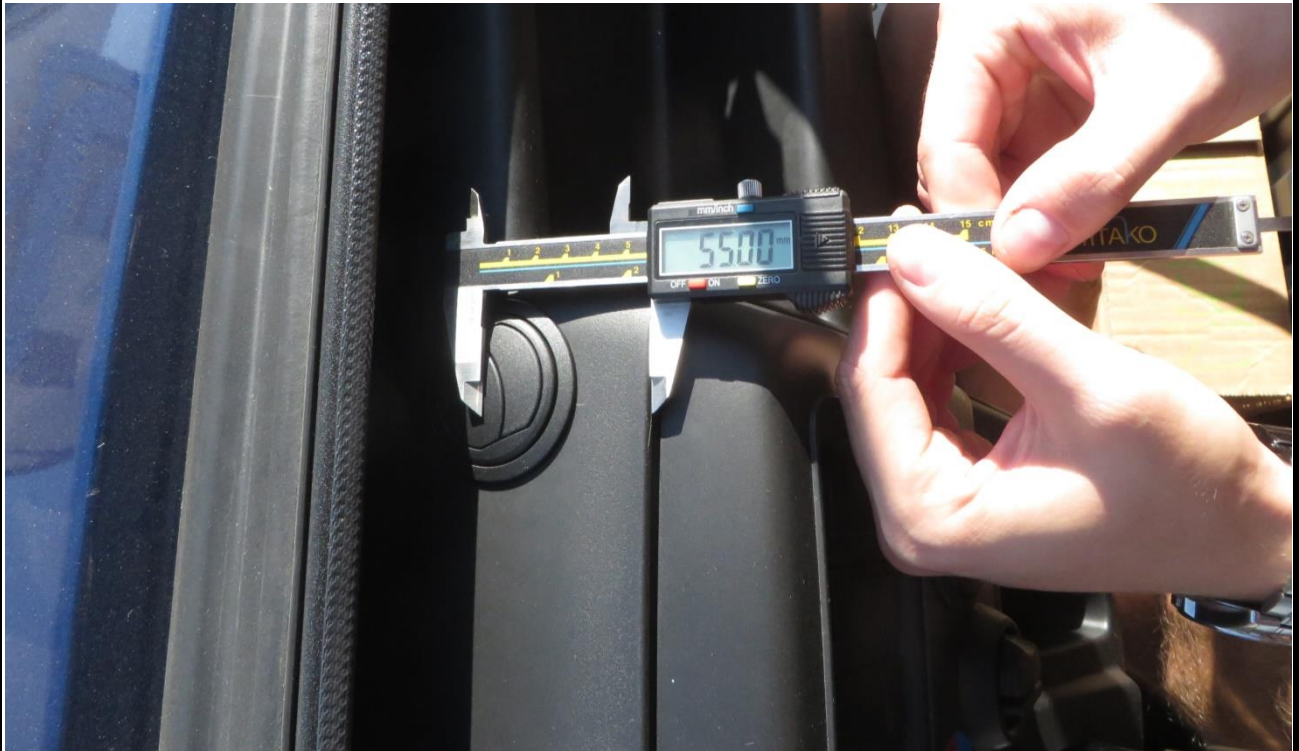

Heater air vents holes horizontal position.



12

Loosen the control panel face fixing screw on the bottom of the compartment. Loosen the shifting lever head fixing screw. Remove the shifting lever head.



Remove the control panel face from the dashboard.



Find the original electroinstallation harness free connector (red circle).

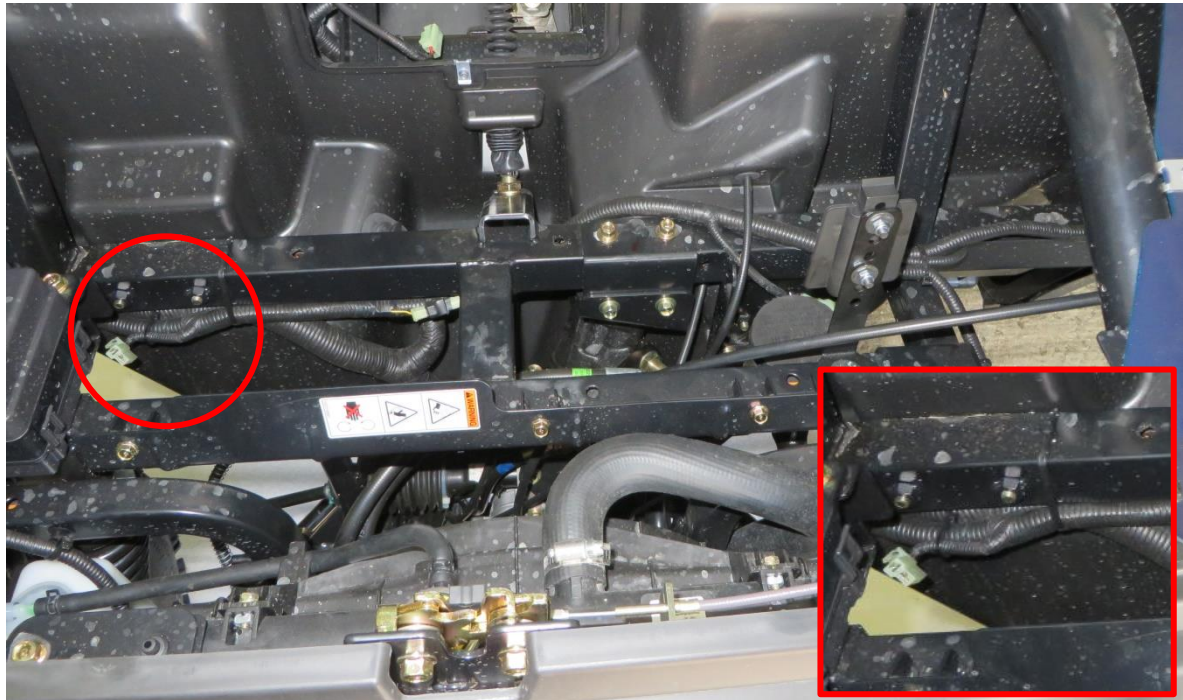

Connect the power supply harness to the original electroinstallation free connector.

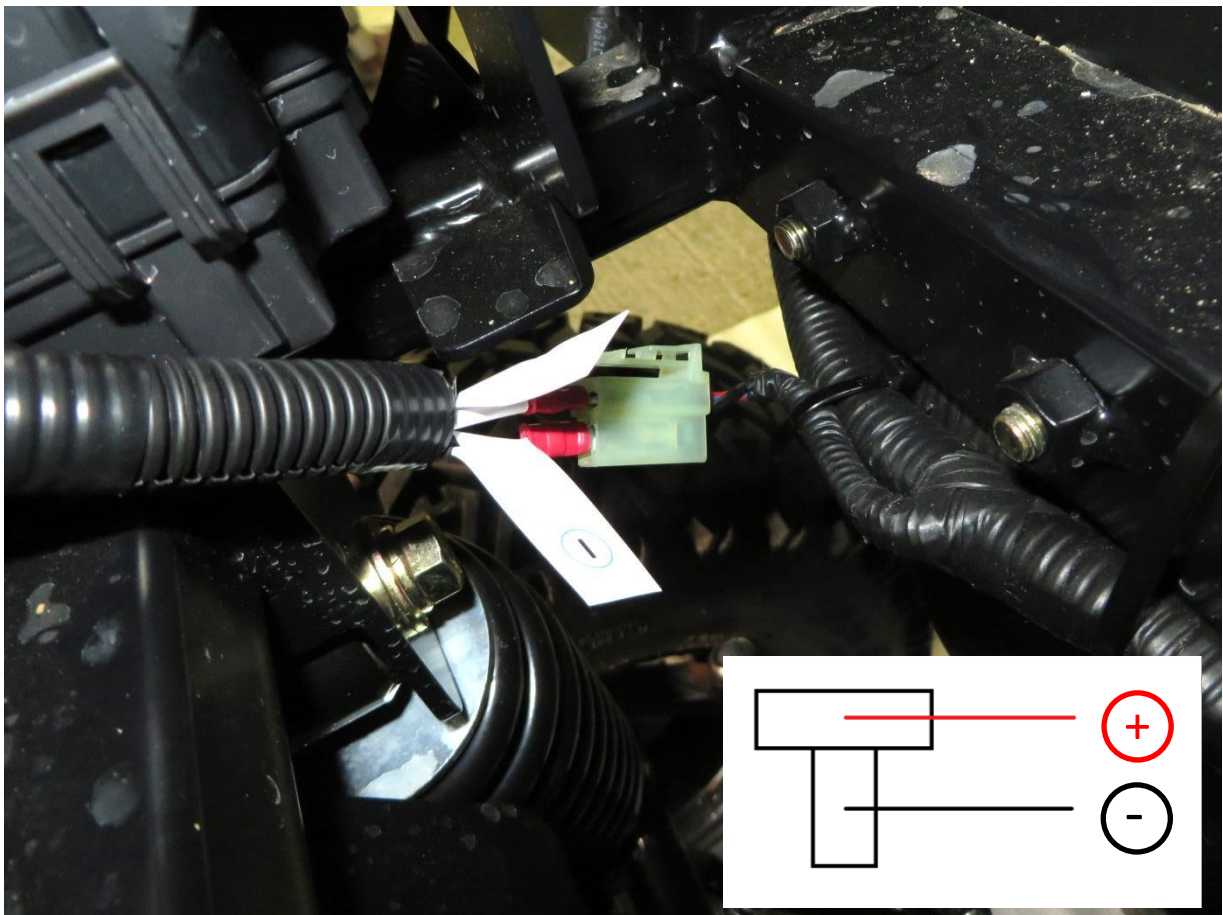

Connect the heater, wiper and washer harness with the power supply harness.

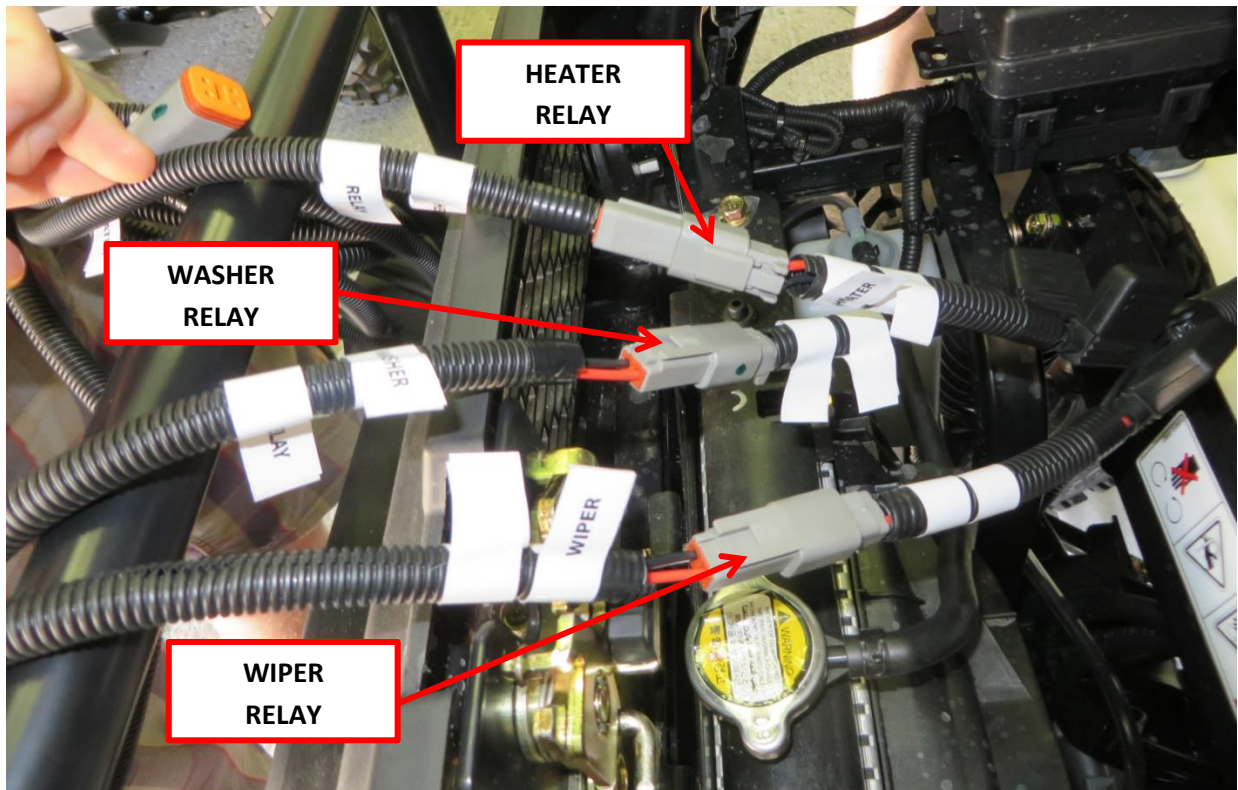

Connect the heater harness with the heater

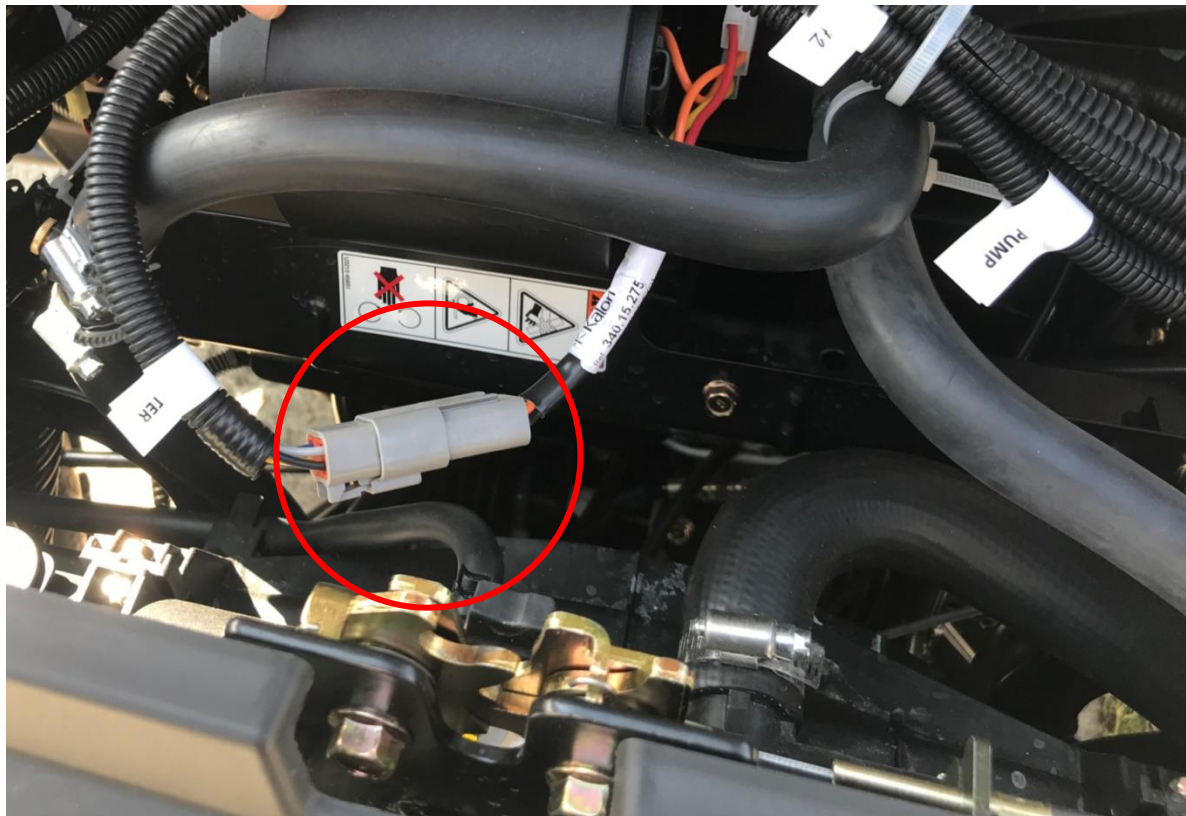

Loosen two screws and remove the partition from the rectangle hole. Route the heater air hoses and the heater harness through this hole.



Route the upper heater air hoses through the prepared holes. Shorten the air hoses to the correct length. Install the air vents onto the air hoses and attach the air hoses with included tightening straps.



Drill four holes \varnothing 75 mm into the original partition for the air hoses.

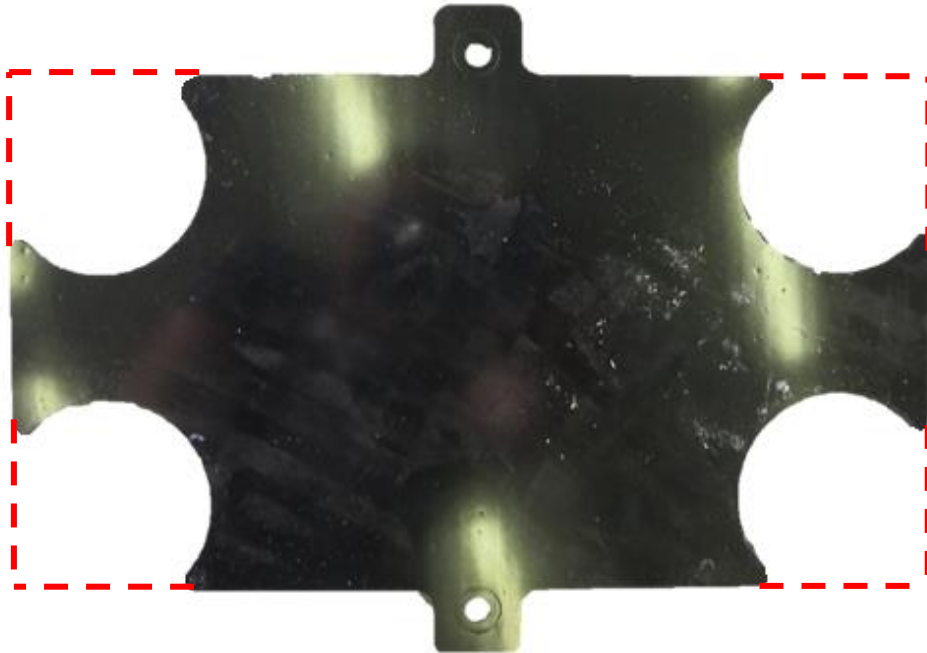

Place the partition back to the original position. Attach the partition with two original screws.

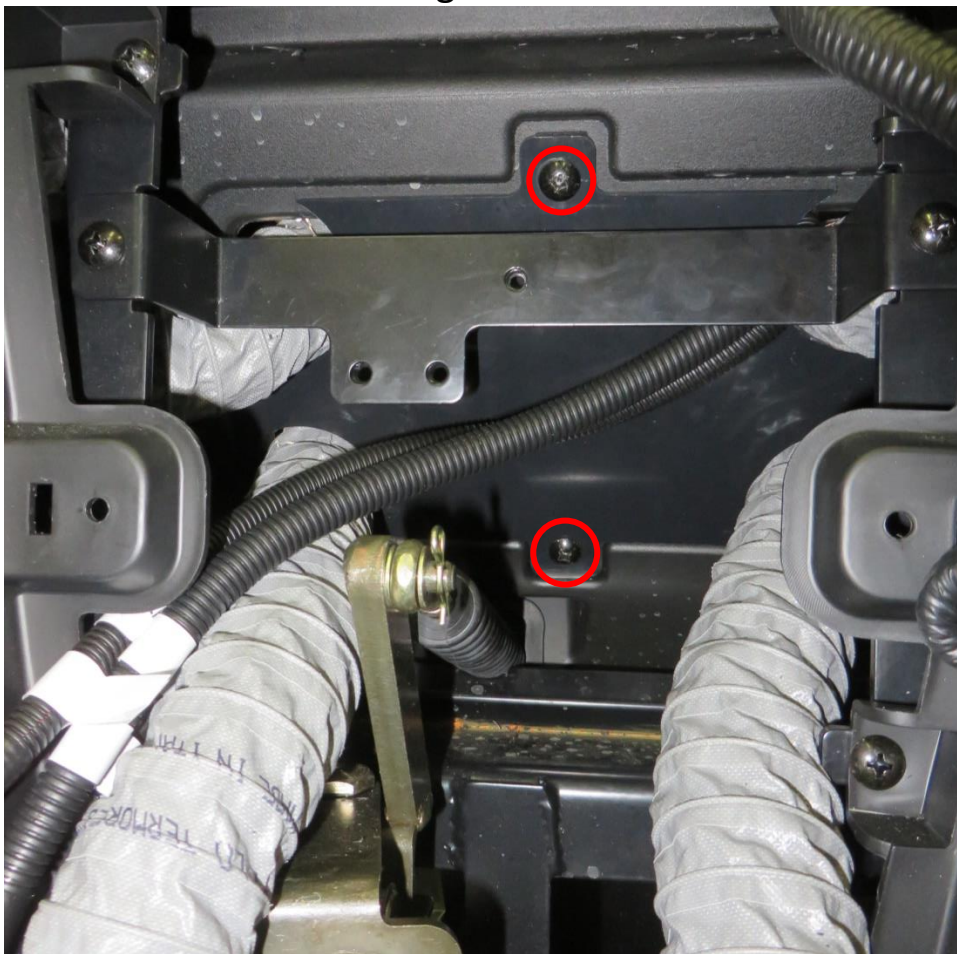

Drill two holes \varnothing 75 mm for the heater air hoses and the heater harness into the control panel face compartment.

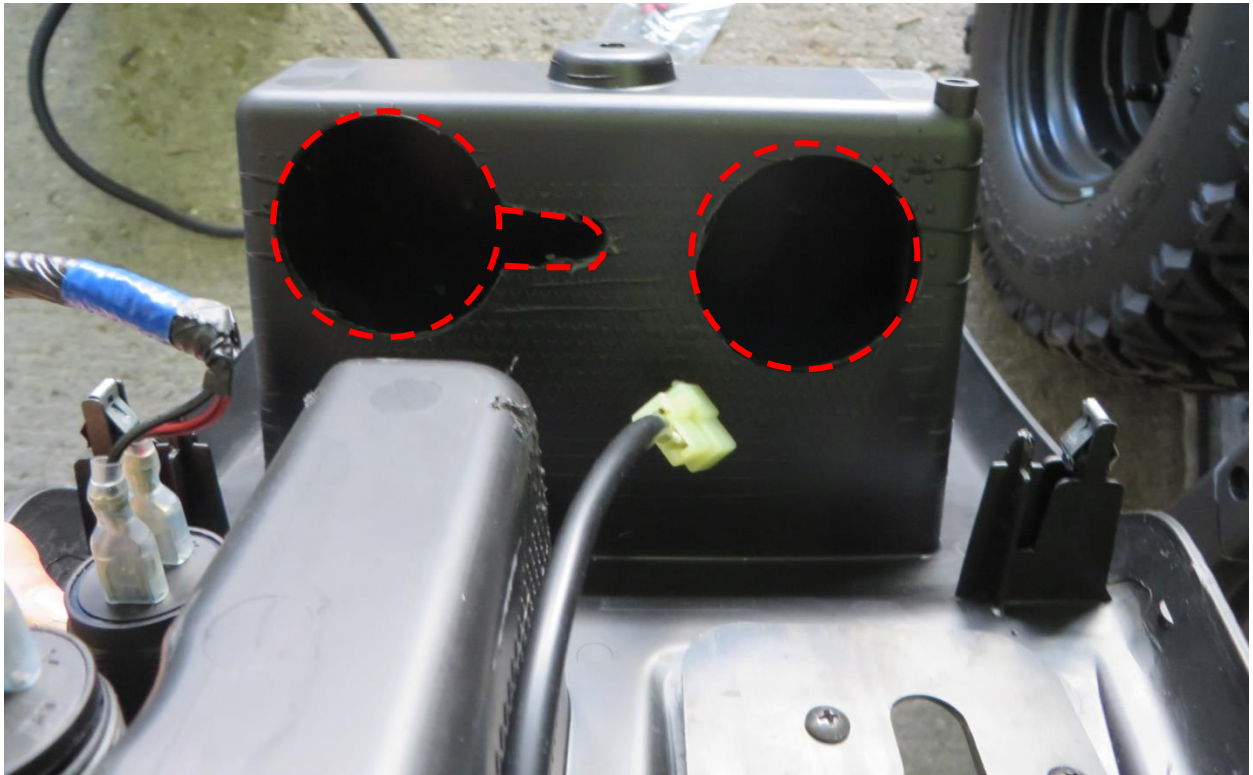

Route the heater air hoses and the heater harness through the prepared holes. Place the control panel face back to the original position and attach with original screw.



Mount the shifting lever head back, attach with original screw.



Shorten the air hoses to the correct length. Install the air vents onto the air hoses and attach the air hoses with included tightening straps. Connect the heater harness with the electromagnetic valve switch and the heater ventilator switch.



Detailed view of the electromagnetic valve switch harness connection.

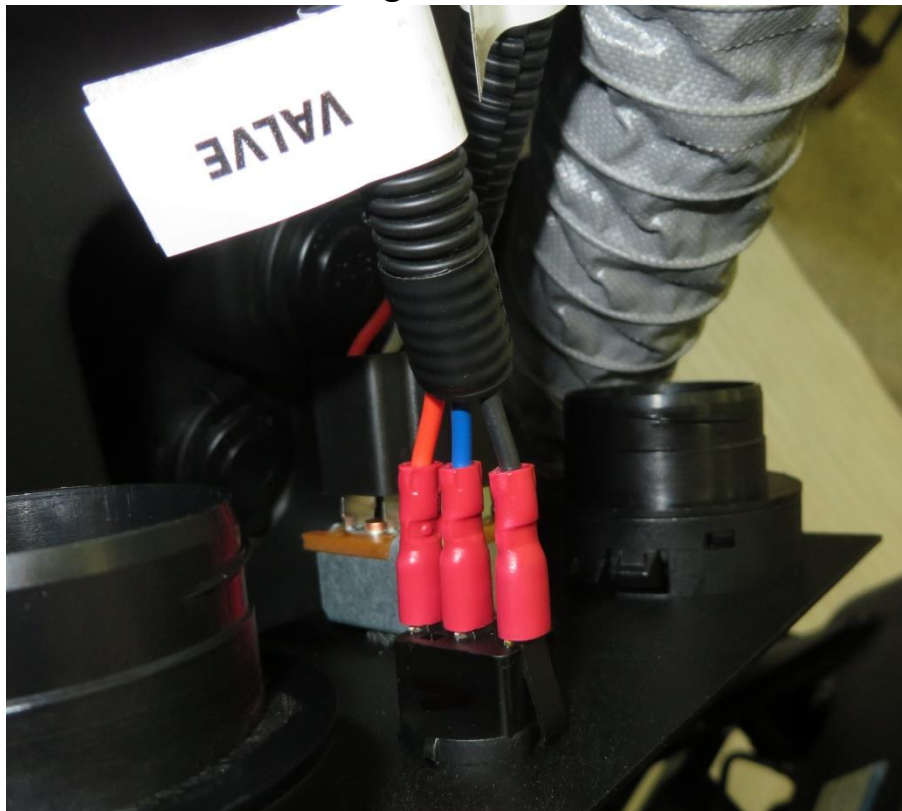

Electromagnetic valve switch scheme of connection.

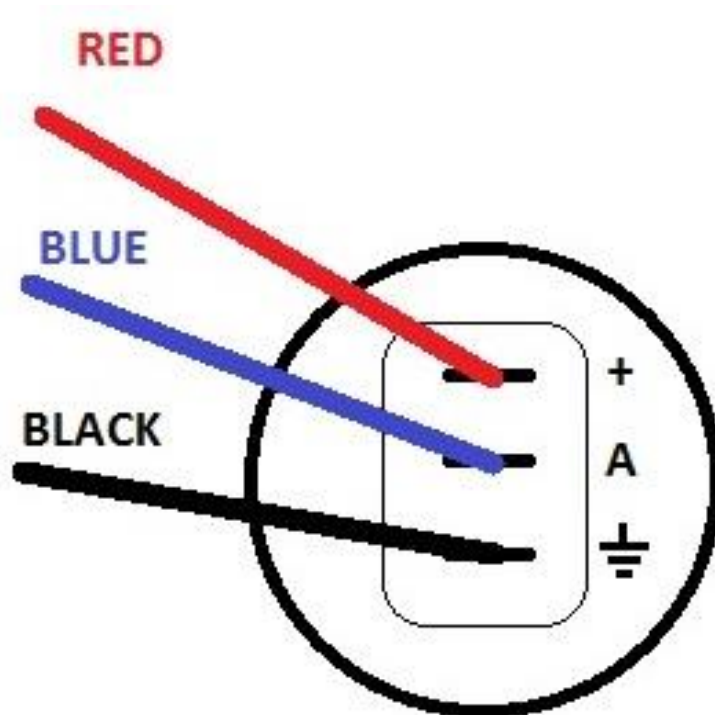

20

Attach the heater control panel with included self-cutting screws.



Connect water pump and the electromagnetic valve harness with the electromagnetic valve.

21

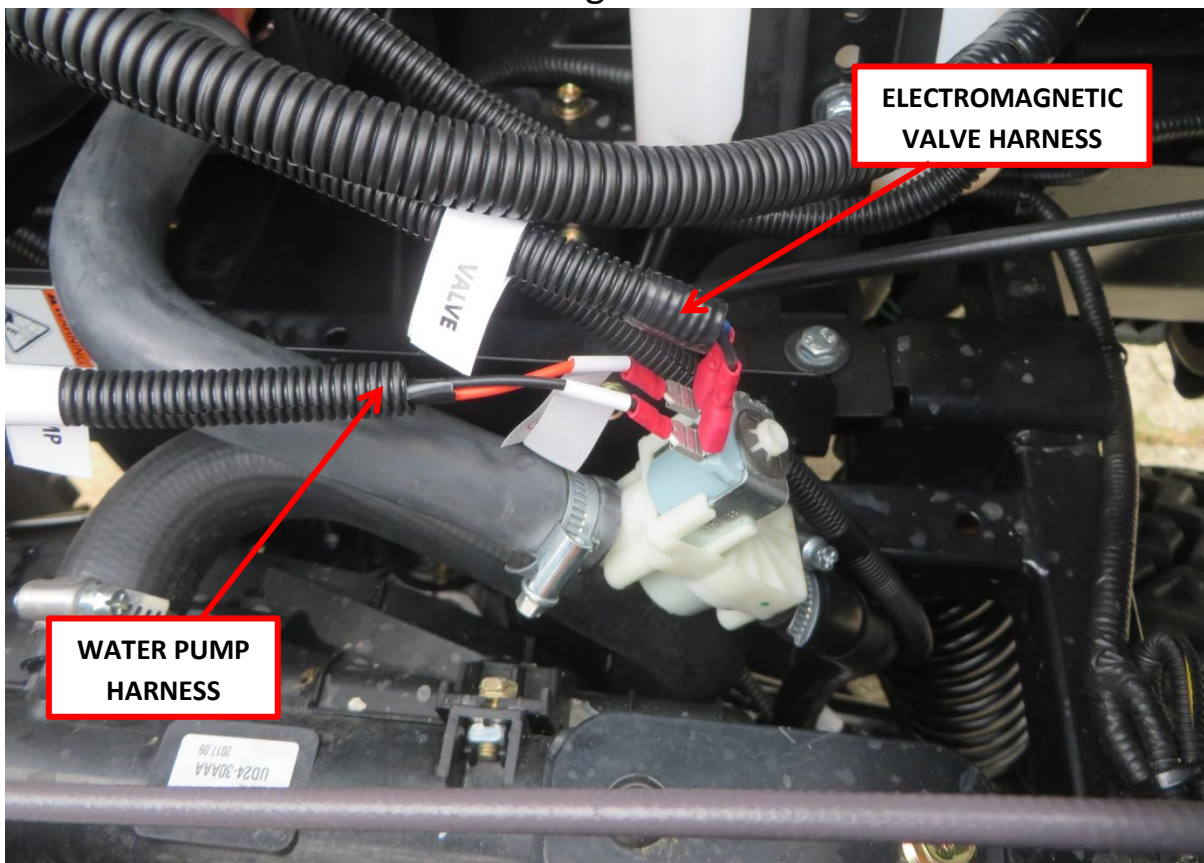

Connect the water pump harness with the water pump. Attach the water pump with included plastic tightening ties to prevent the water pump damage.

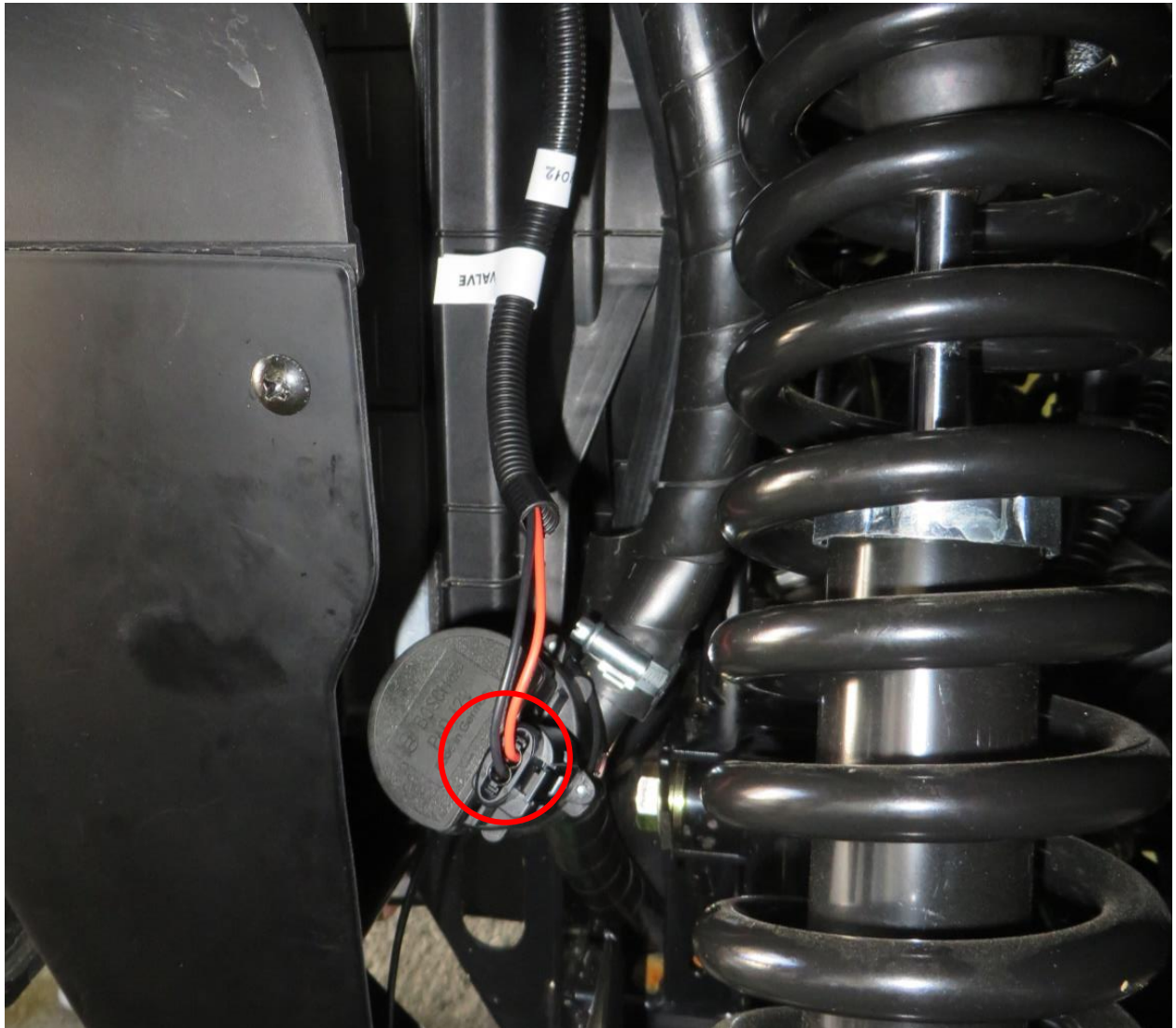

22

WIPER/WASHER

Mount the washer tank holder with included fixing assembly.

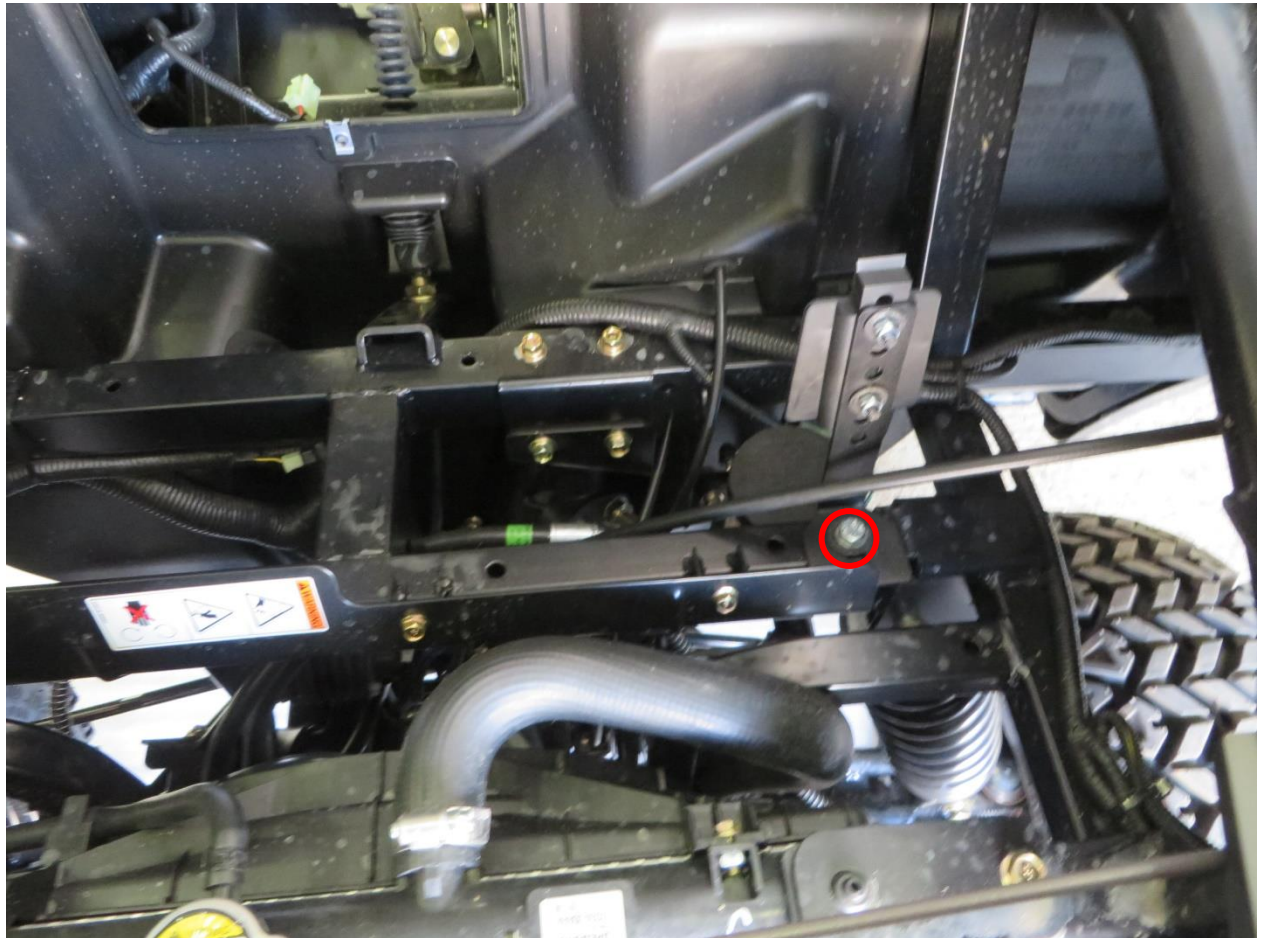

23

Connect the washer harness and the washer tube with the washer motor.



Install the washer tank onto the washer tank holder.



Route the wiper and washer harness to the right side of the under hood space.

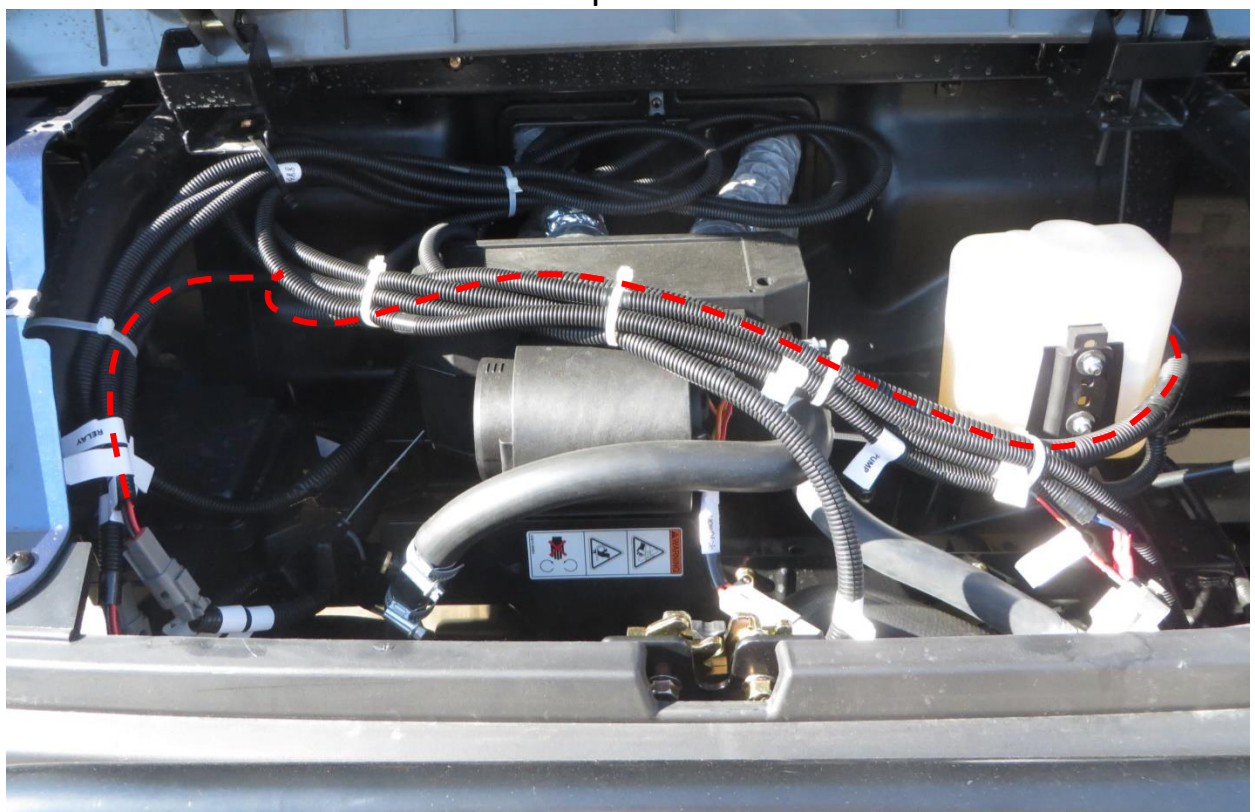

24

Drill hole \varnothing 30 mm for the wiper and washer harness and route the washer and wiper harness through the hole.

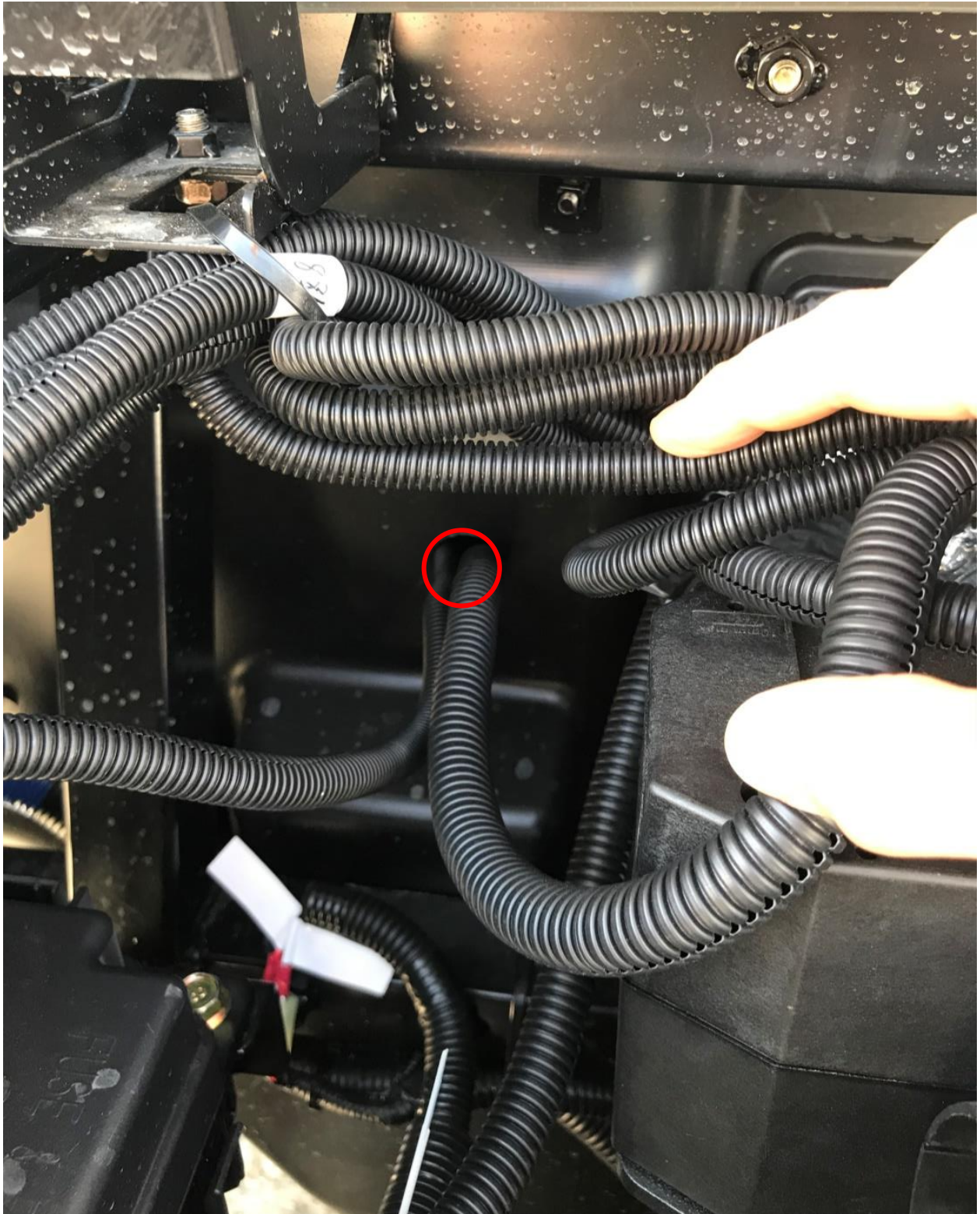

25

Drill hole \varnothing 30 mm for the wiper and washer harness to the UTV dashboard. Route the wiper and washer harness through the hole.



26

Route the wiper and washer harness up to the front upper ledge.



27

Connect the wiper and washer harness with the wiper motor control panel with wiper/washer switch.



Attach the wiper and washer harness with included tightening ties to the UTV roll cage.



Install the wiper arm with wiper blade onto the wiper motor shaft. Attach the wiper arm with included fixing assembly. Connect the washer tube with the washer jet.



29

PREPARATION FOR INSTALLATION:

Uninstall all additional systems from the roller cages (work lights, rear mirrors, drink holders etc.)

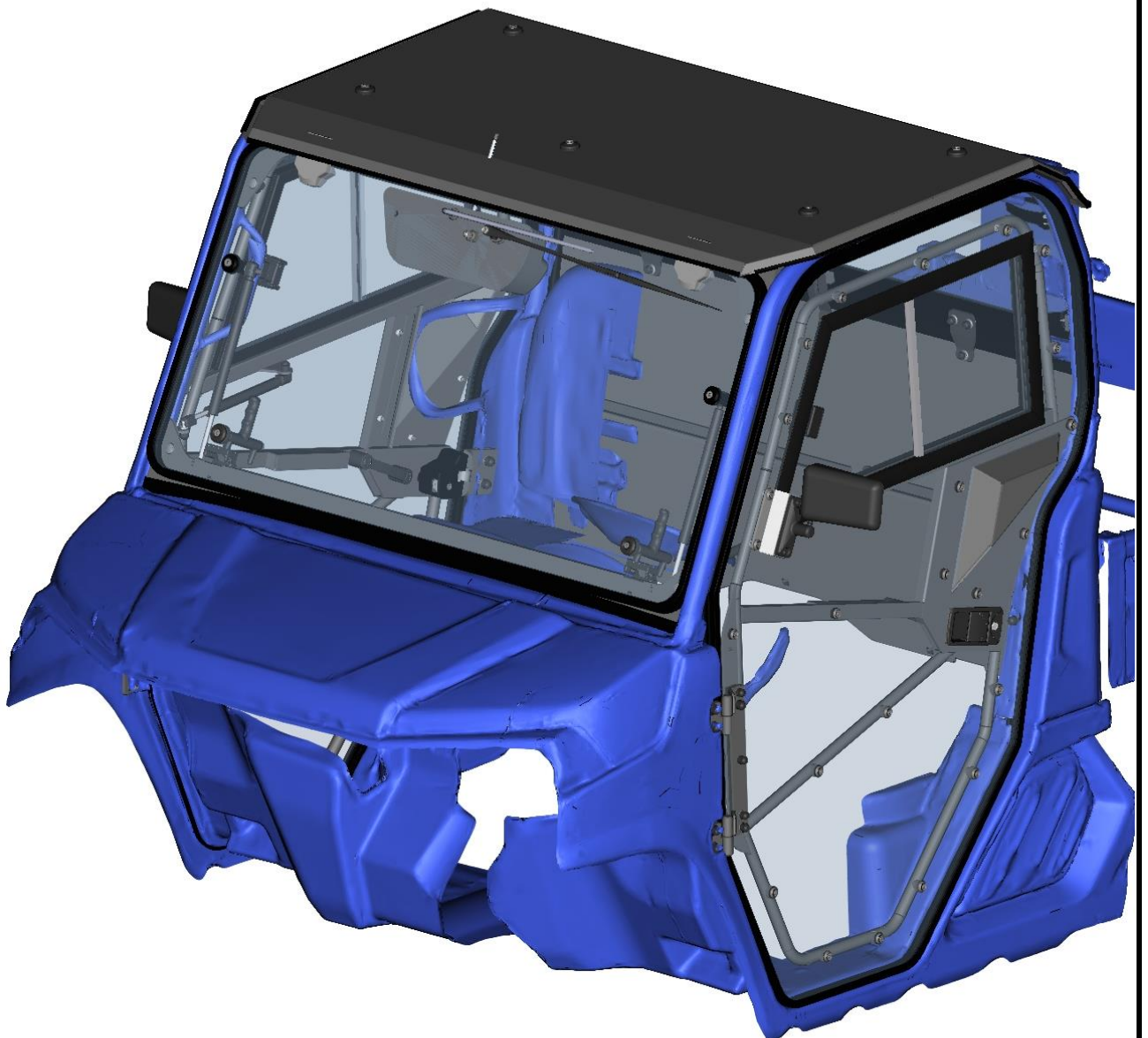
CAB PREVIEW

30

FRONT PANEL

Place the front bottom ledge onto UTV roll cage and the UTV body.

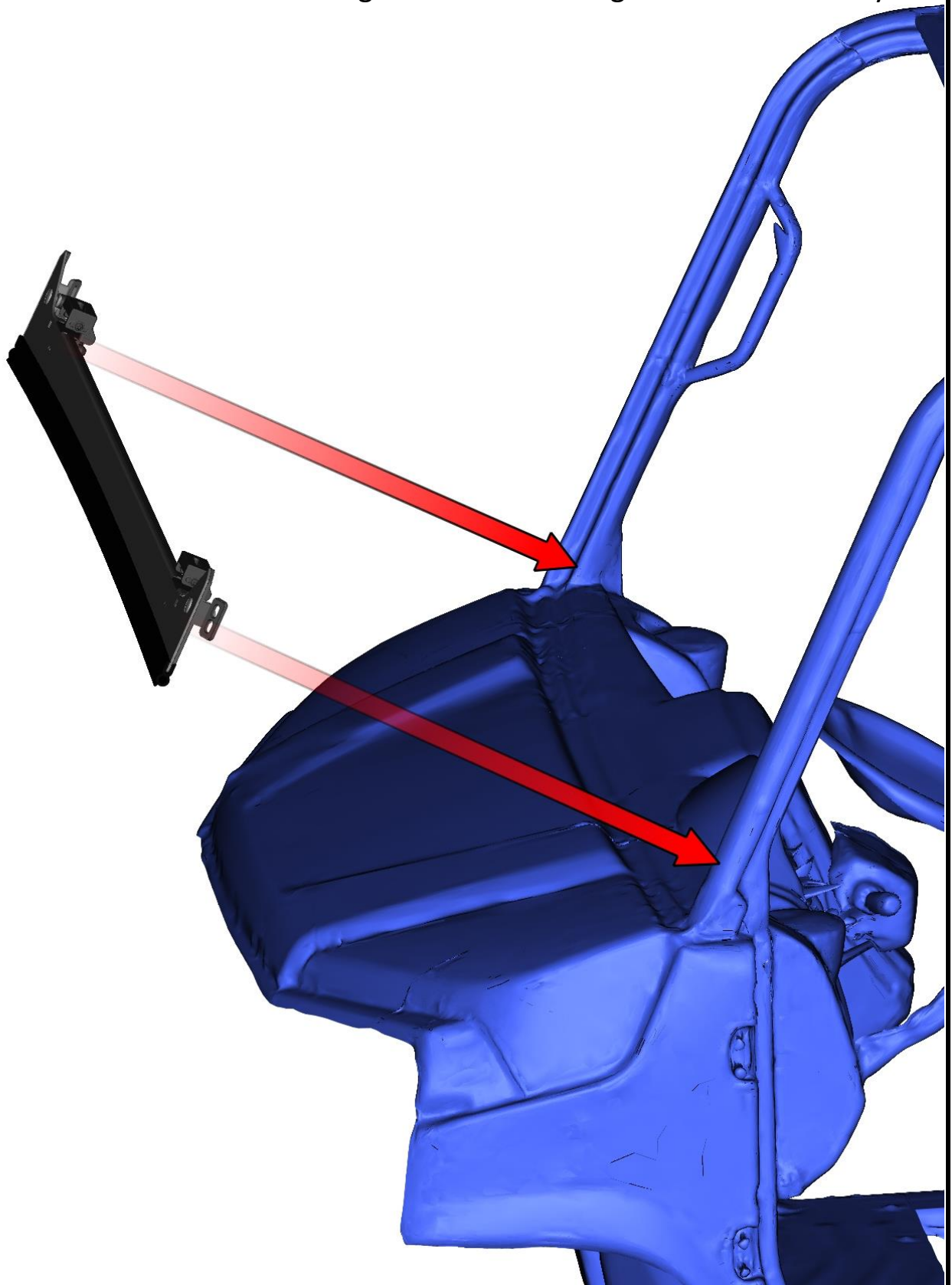

31

Turn the front bottom ledge to the correct position and attach the front bottom ledge with included washers, screws and covers on both sides.

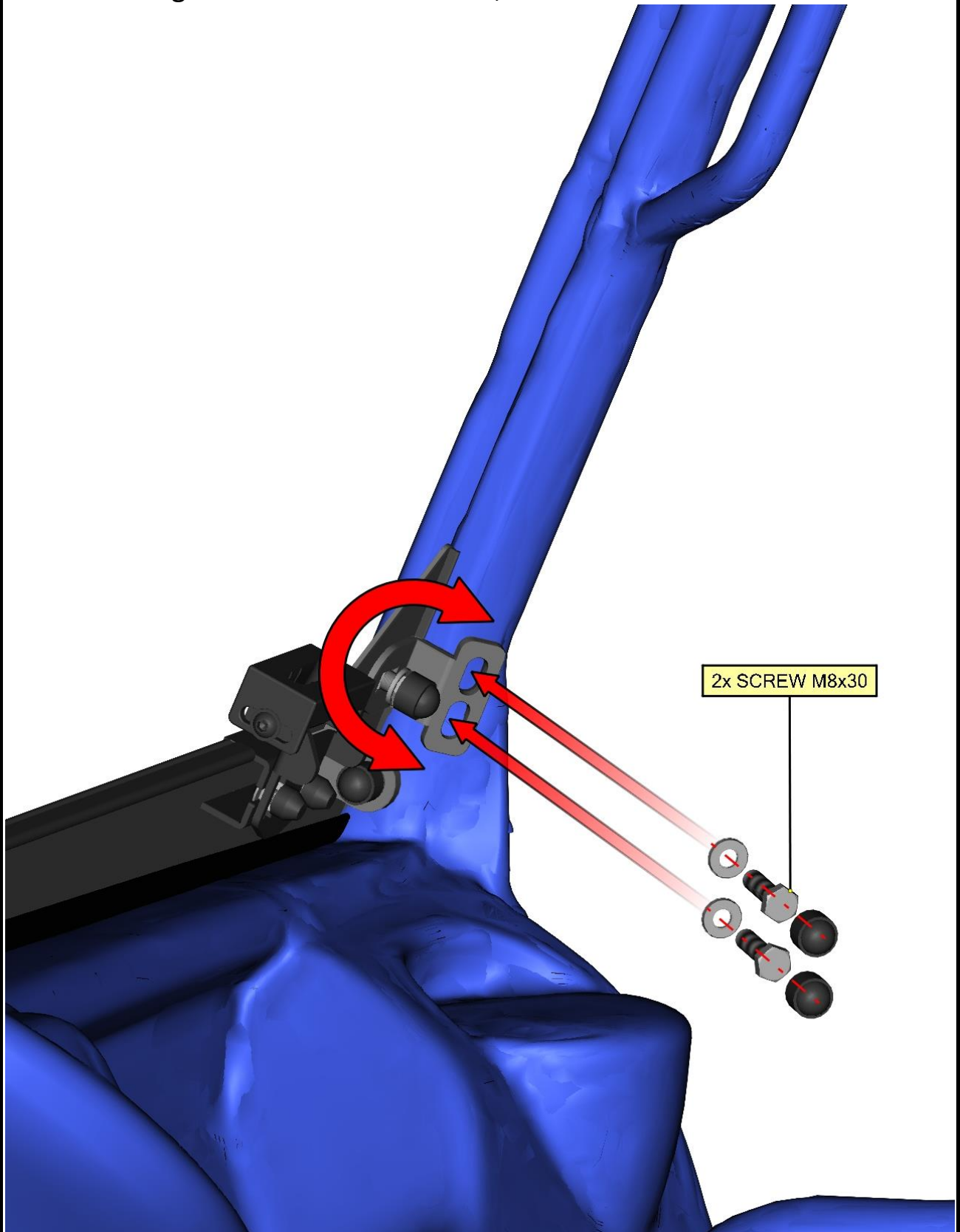

If you have the cab with doors, mount the door gas spring holder with the front bottom edge holder on both sides.

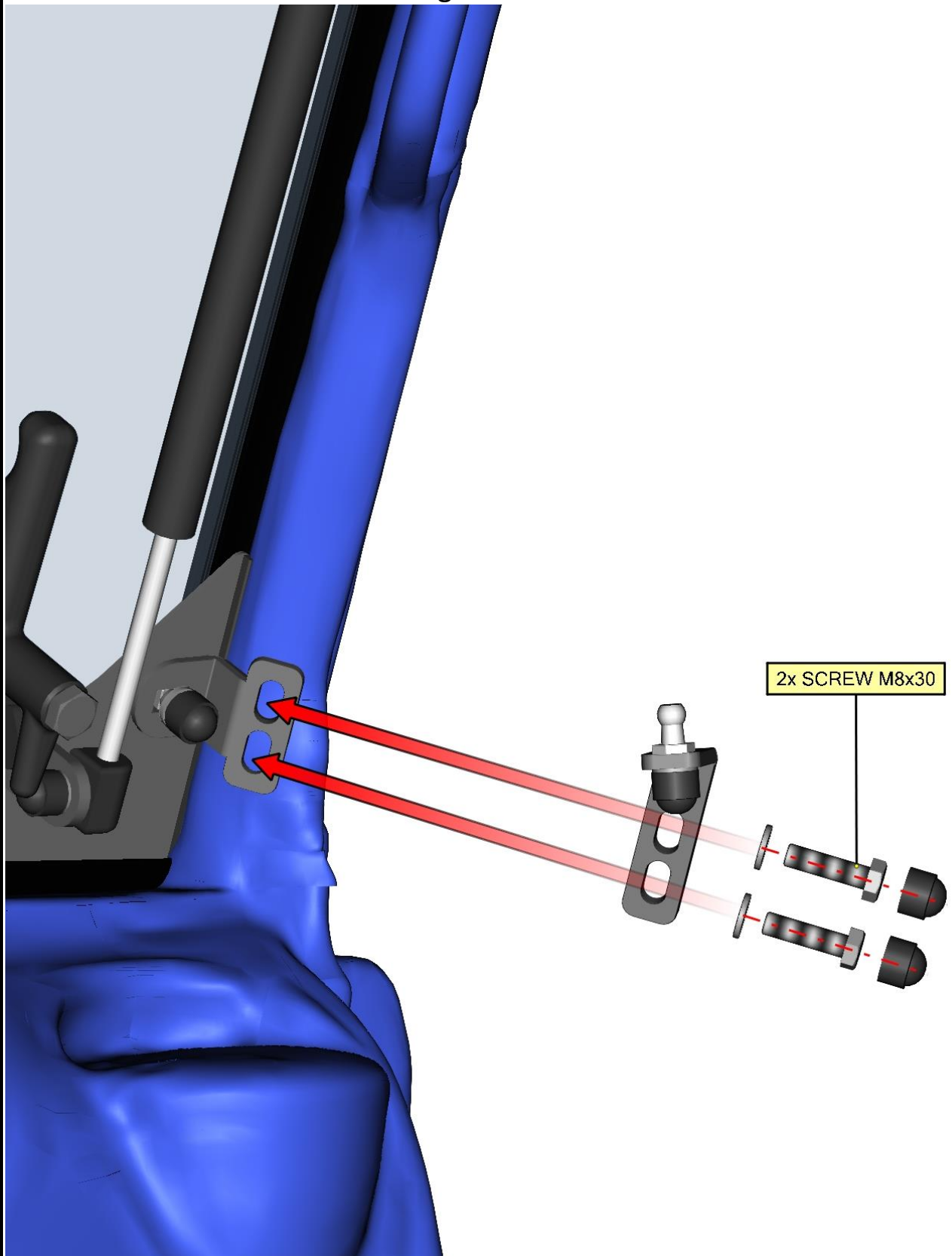

Place the front upper ledge onto the UTV roll cage.

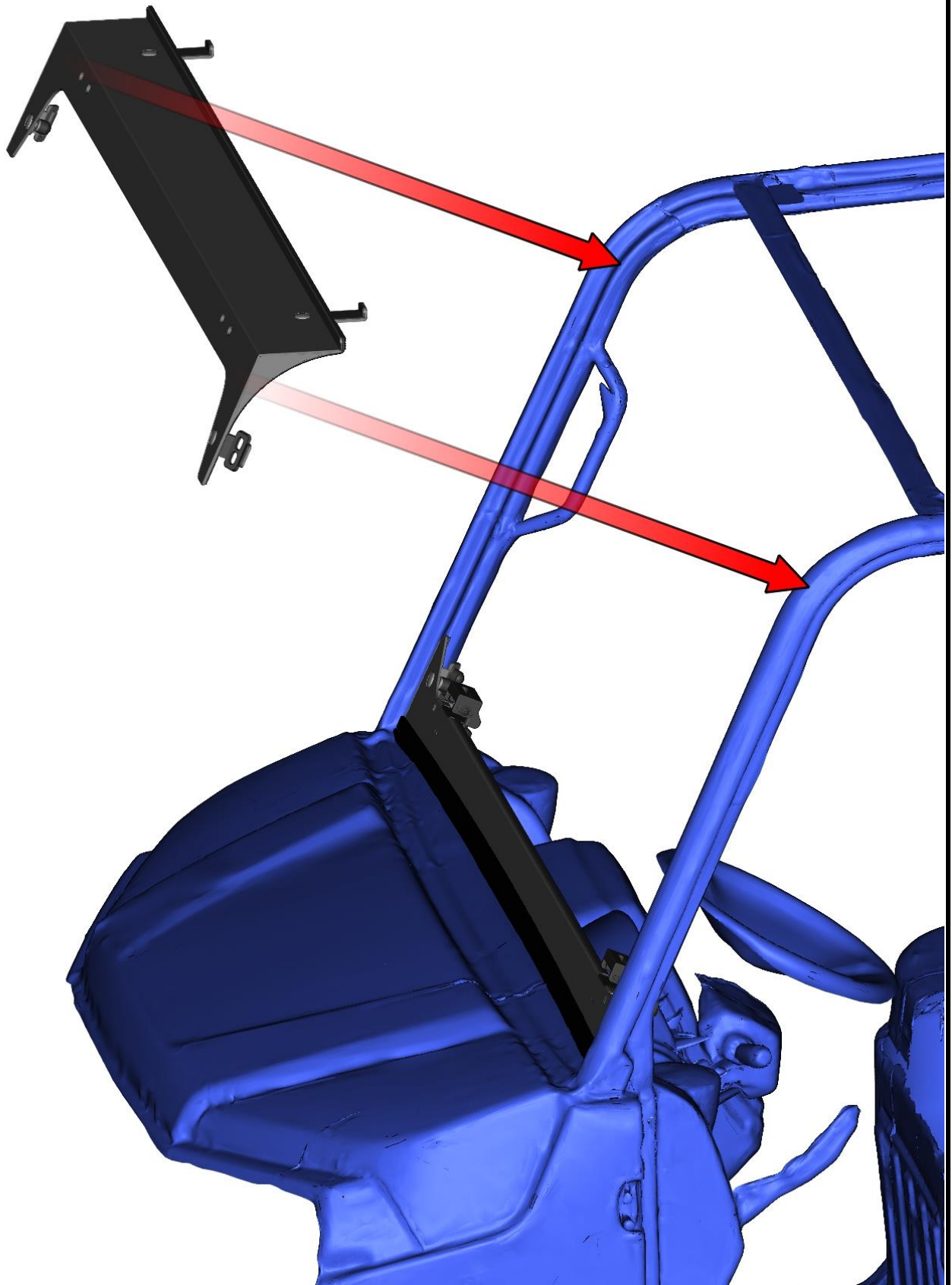

34

Turn the front upper ledge holders to the correct position and tighten the holders screws.

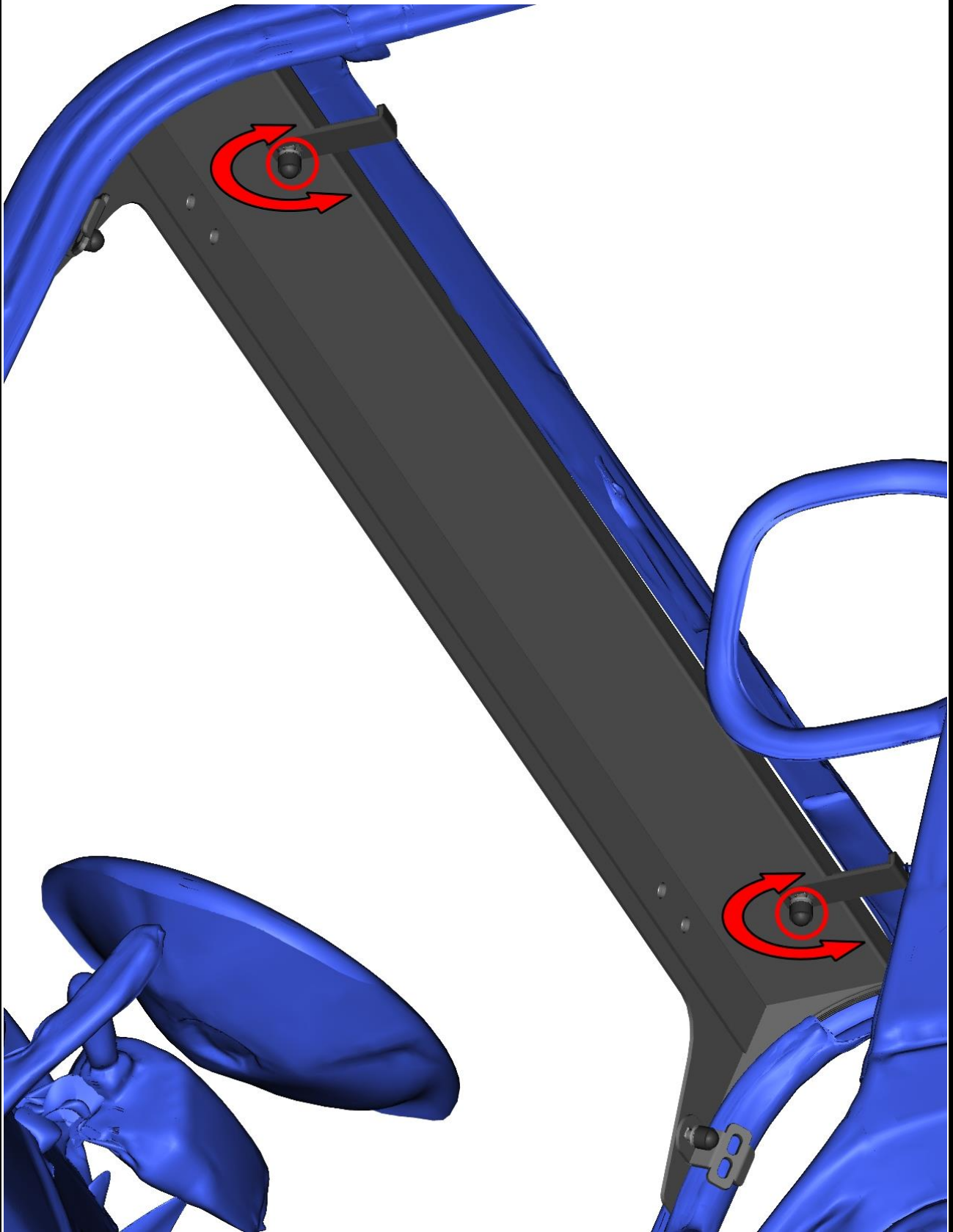

35

Attach the front upper ledge with included washers, screws and covers on both sides.

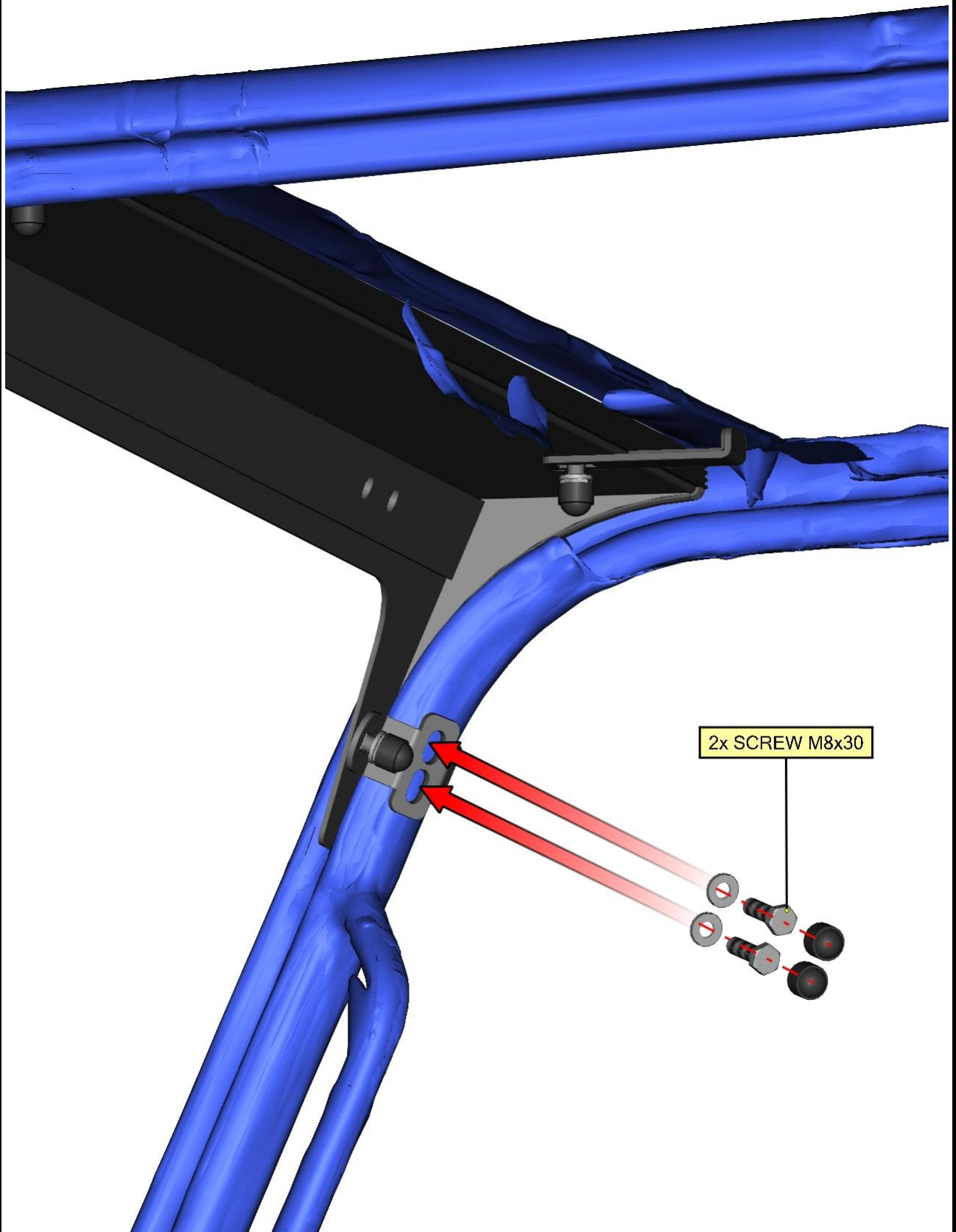

36

Place the front glass assembly onto the front upper and bottom ledge.
Adjust the front glass assembly to the best position.

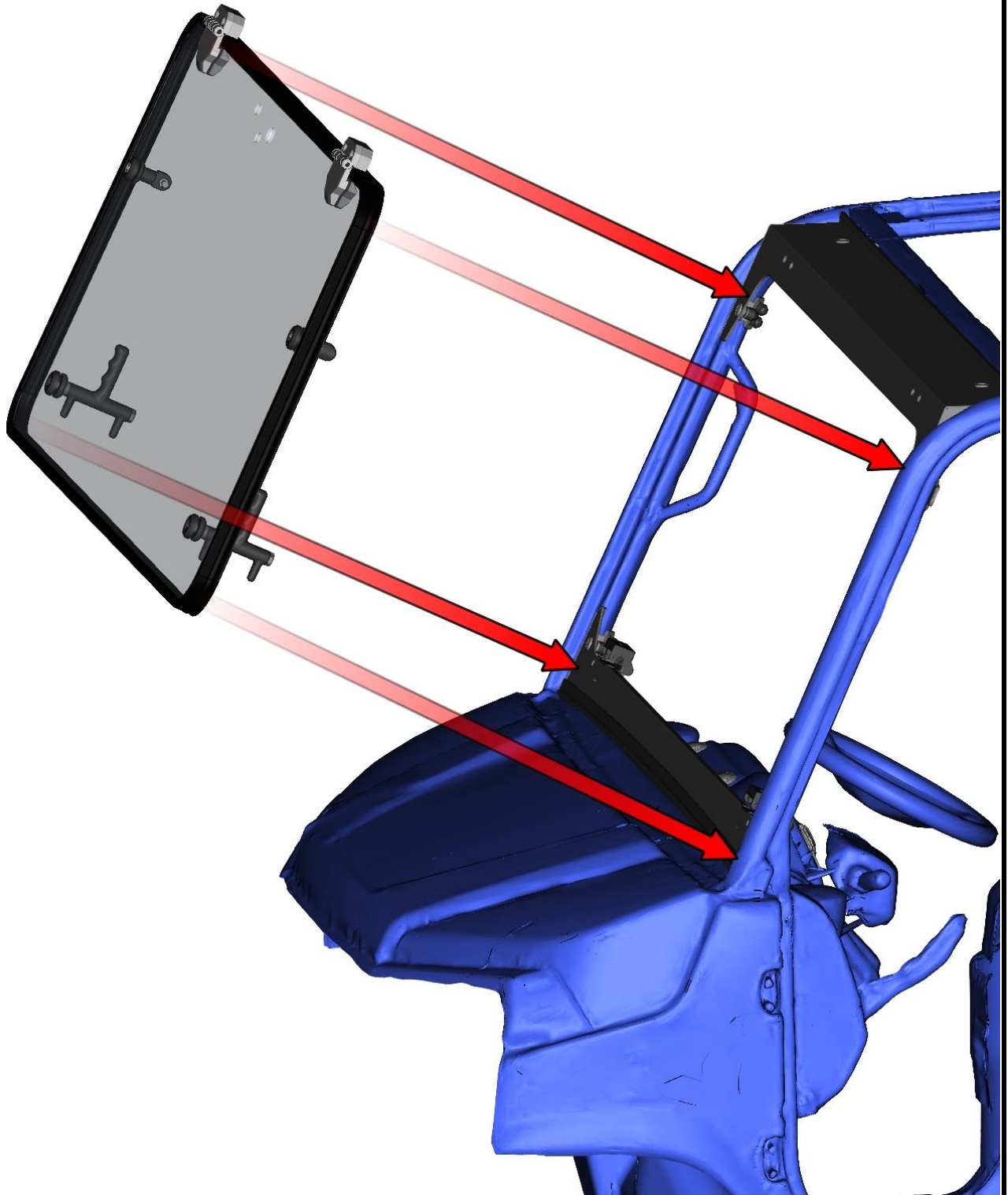

37

Attach the front glass assembly with included fixing assemblies.

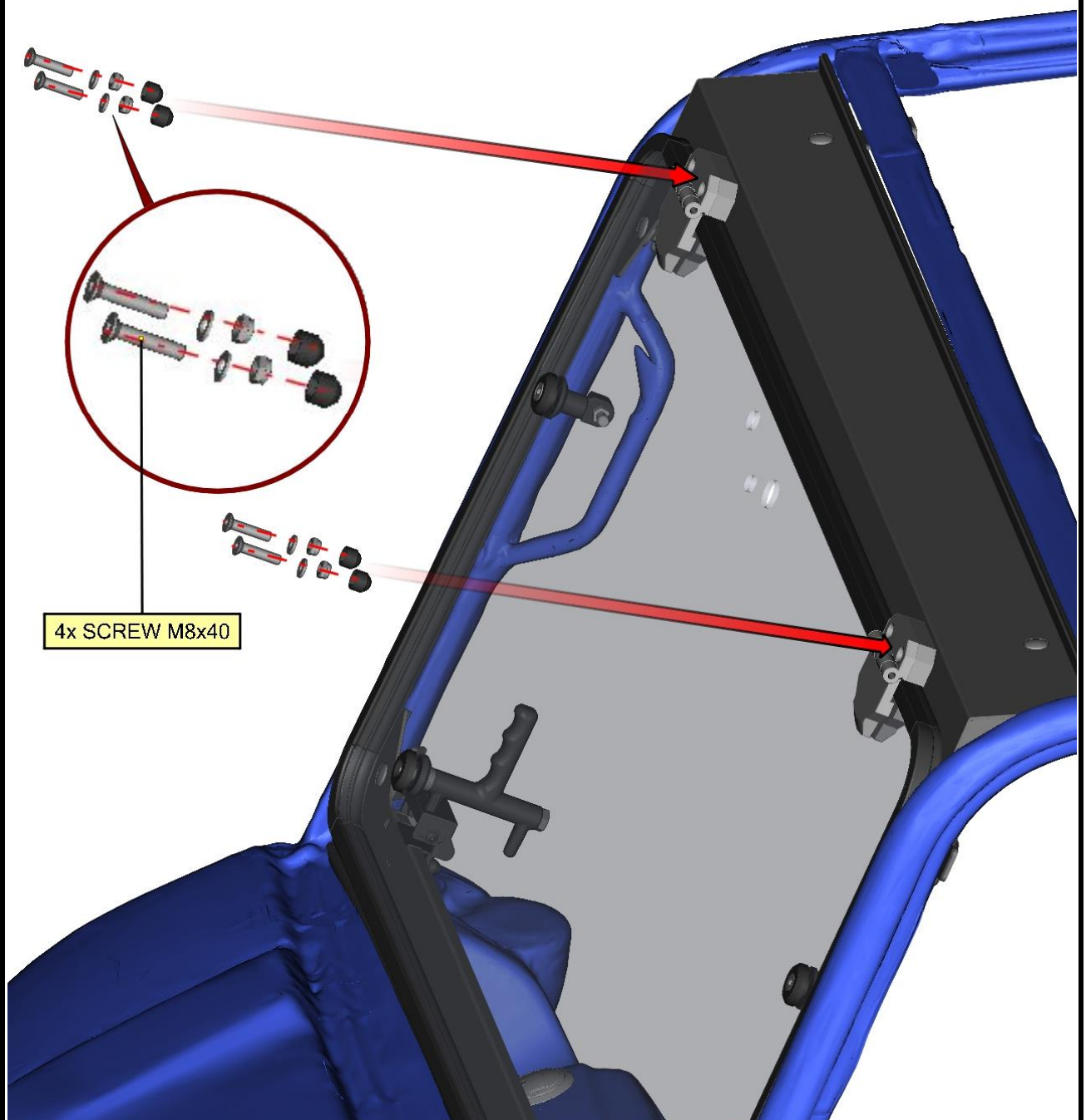

38

Install the front panel gas spring onto the gas spring holders pins.

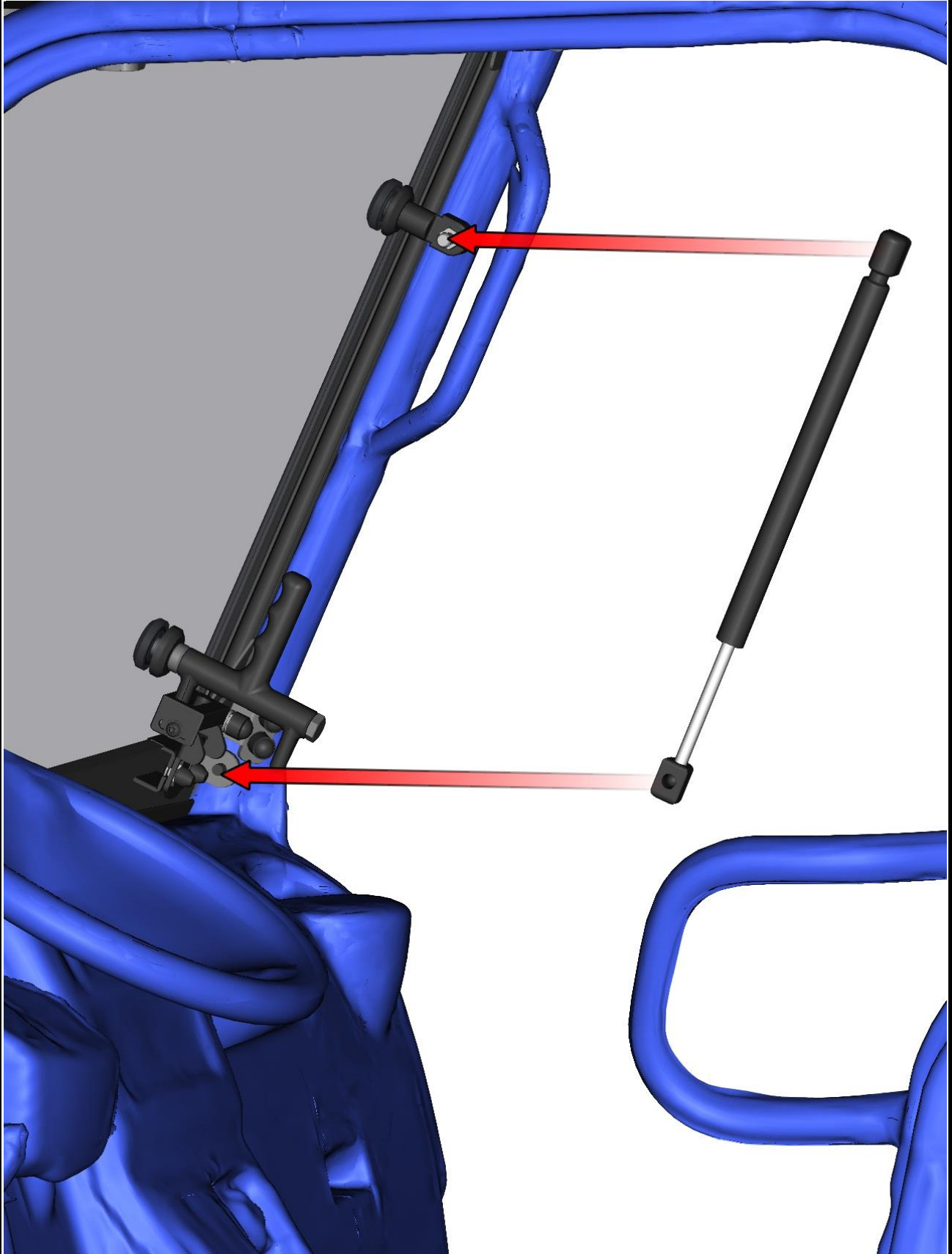

39

Adjust the front glass stop to the best position and tighten the fixing screws hard.

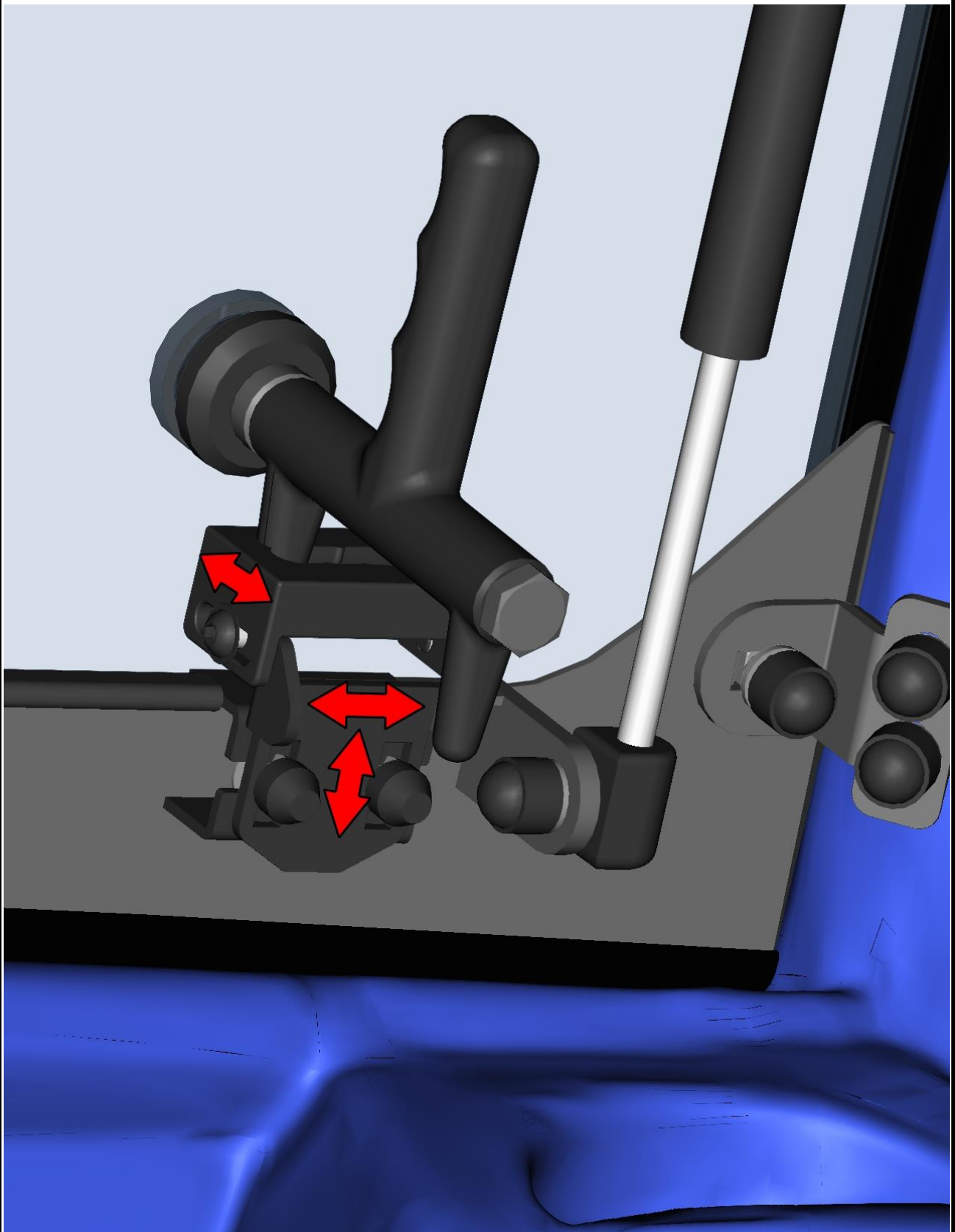

40

REAR PANEL

Loosen three screws on the plastic UTV roll cage cover.



41

Loosen two screws on the plastic UTV roll cage cover and remove the cover before rear panel installation.



42

Place the bottom rear panel onto the UTV roll cage. Adjust the bottom rear panel to the best position.

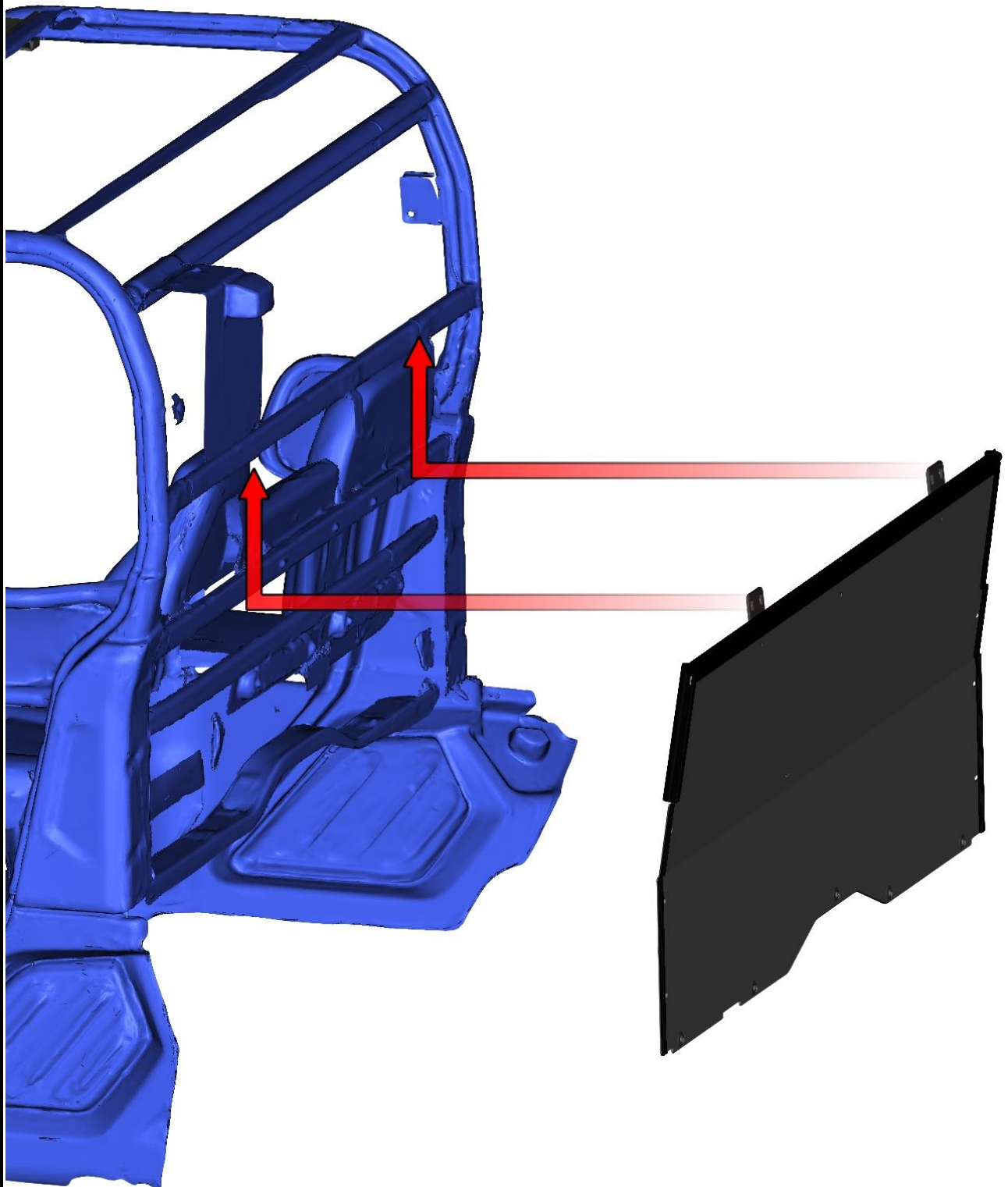

Attach the bottom rear panel with included fixing assemblies.

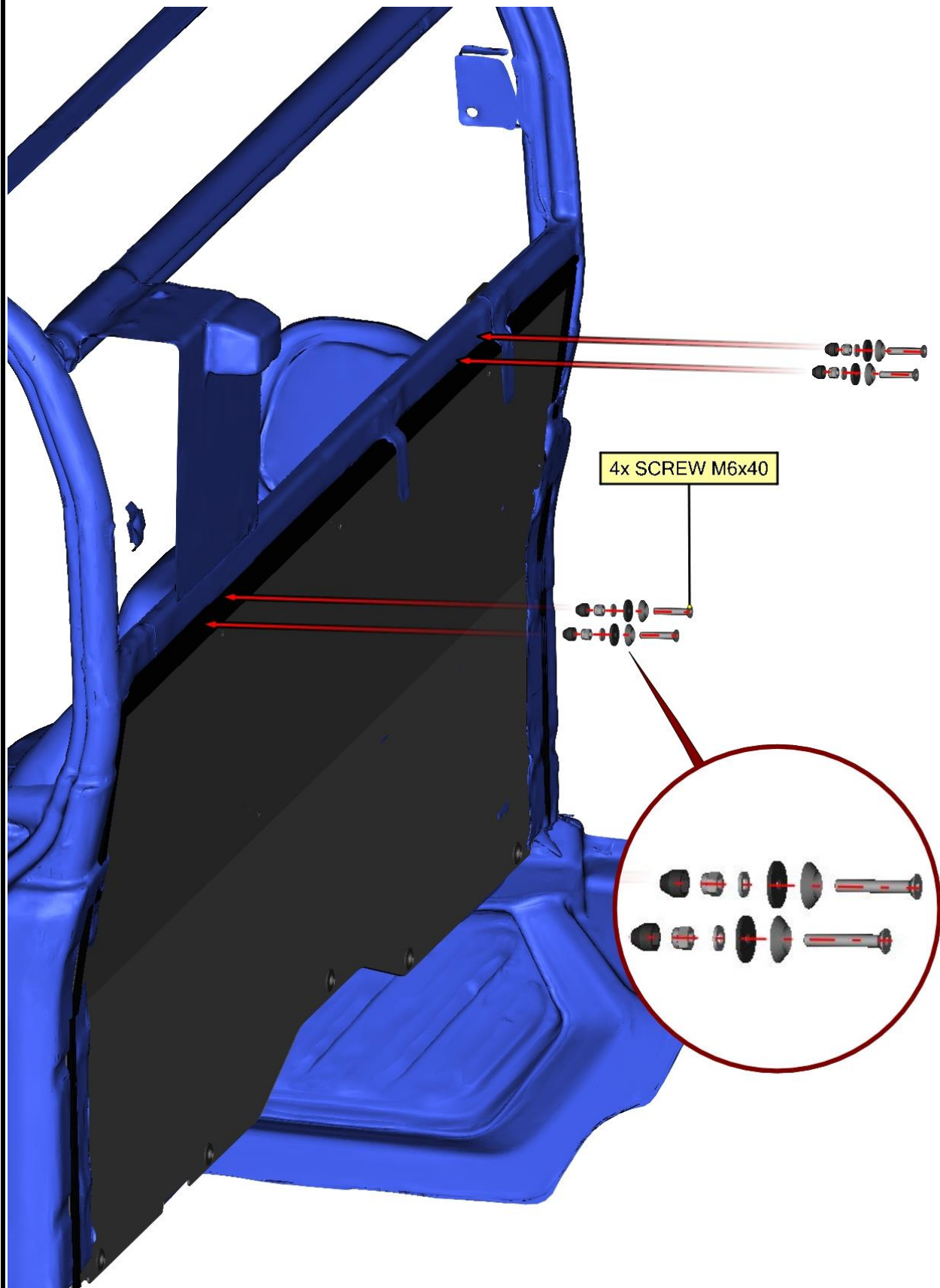

Attach the bottom rear panel with the holder in the middle of the panel.

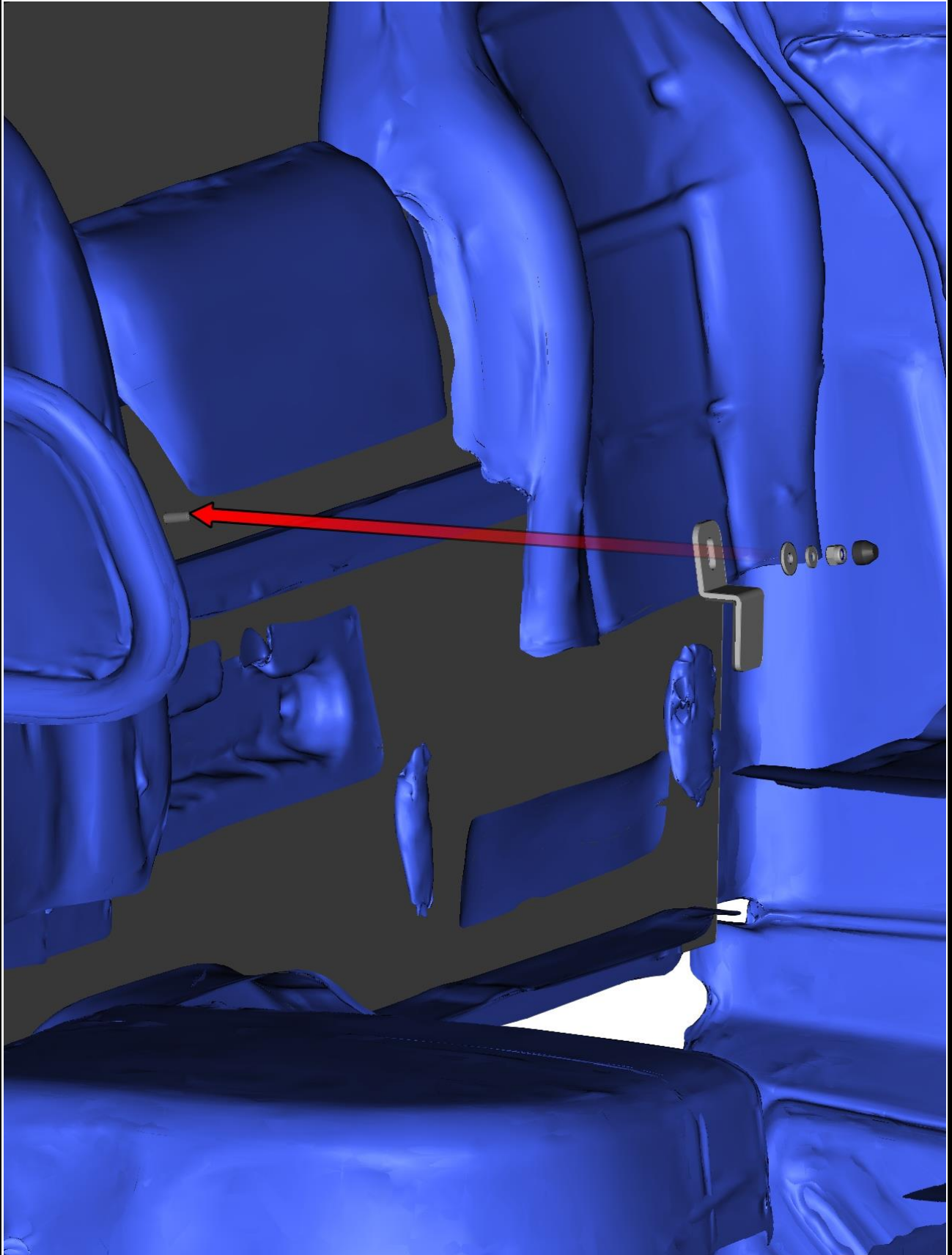

45

Attach the rear bottom panel at the bottom with included washers and screws (use original frame holes).

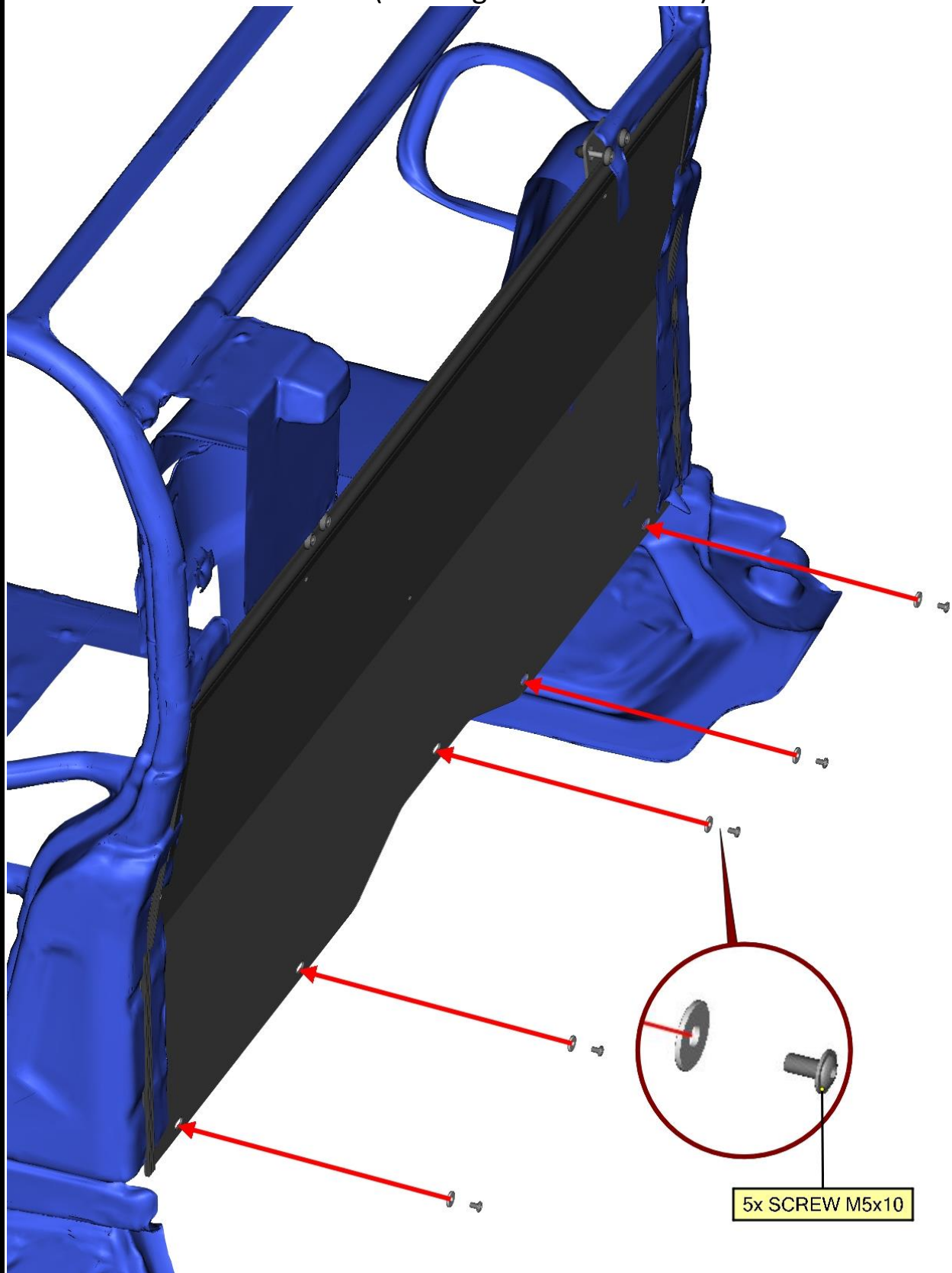

46

Cut the rectangle 16 x 18 mm hole into the original plastic UTV roll cage cover onto the original circle hole position.



47

Place the rear upper panel onto the UTV roll cage.

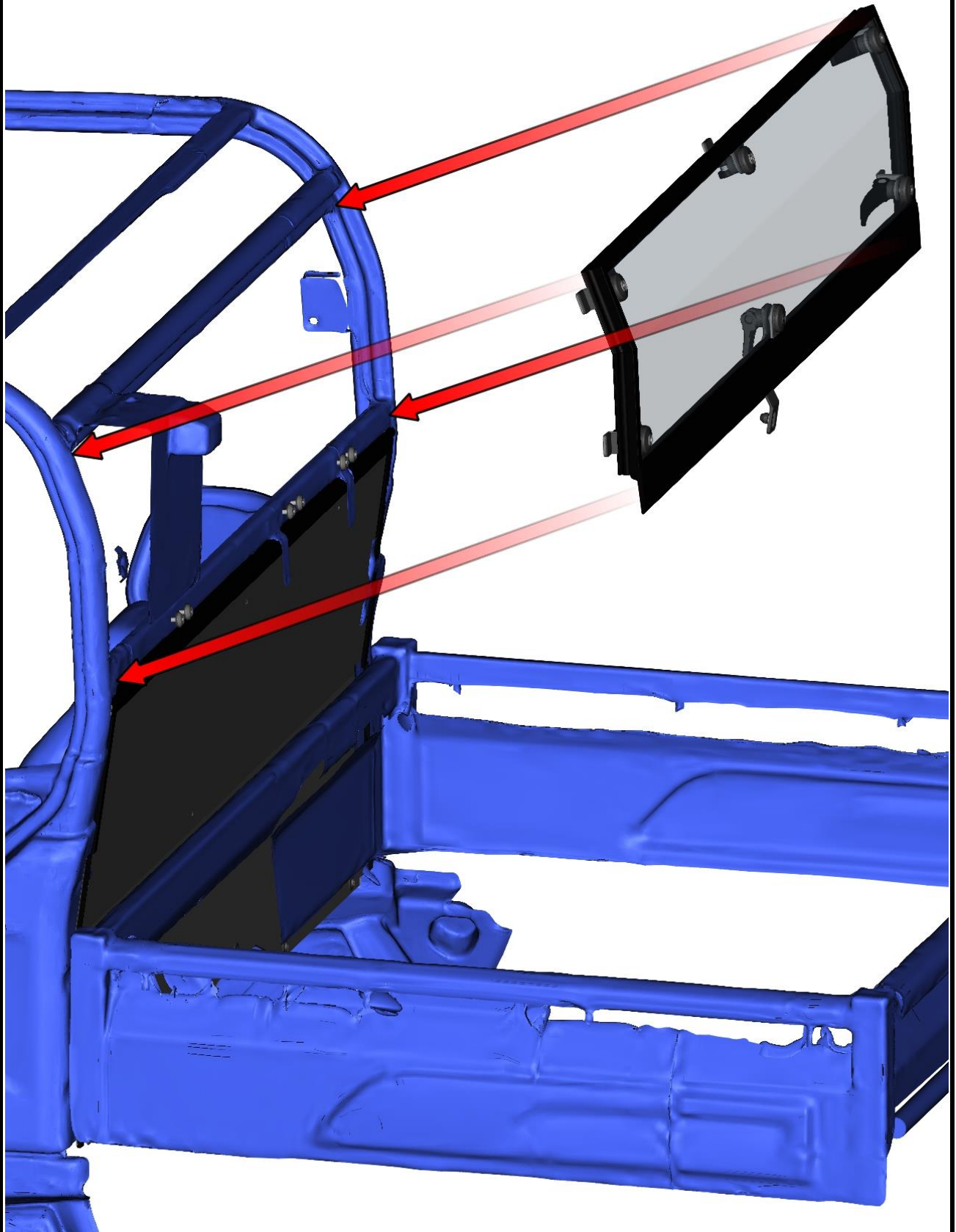

48

Adjust the rear upper panel to the best position.

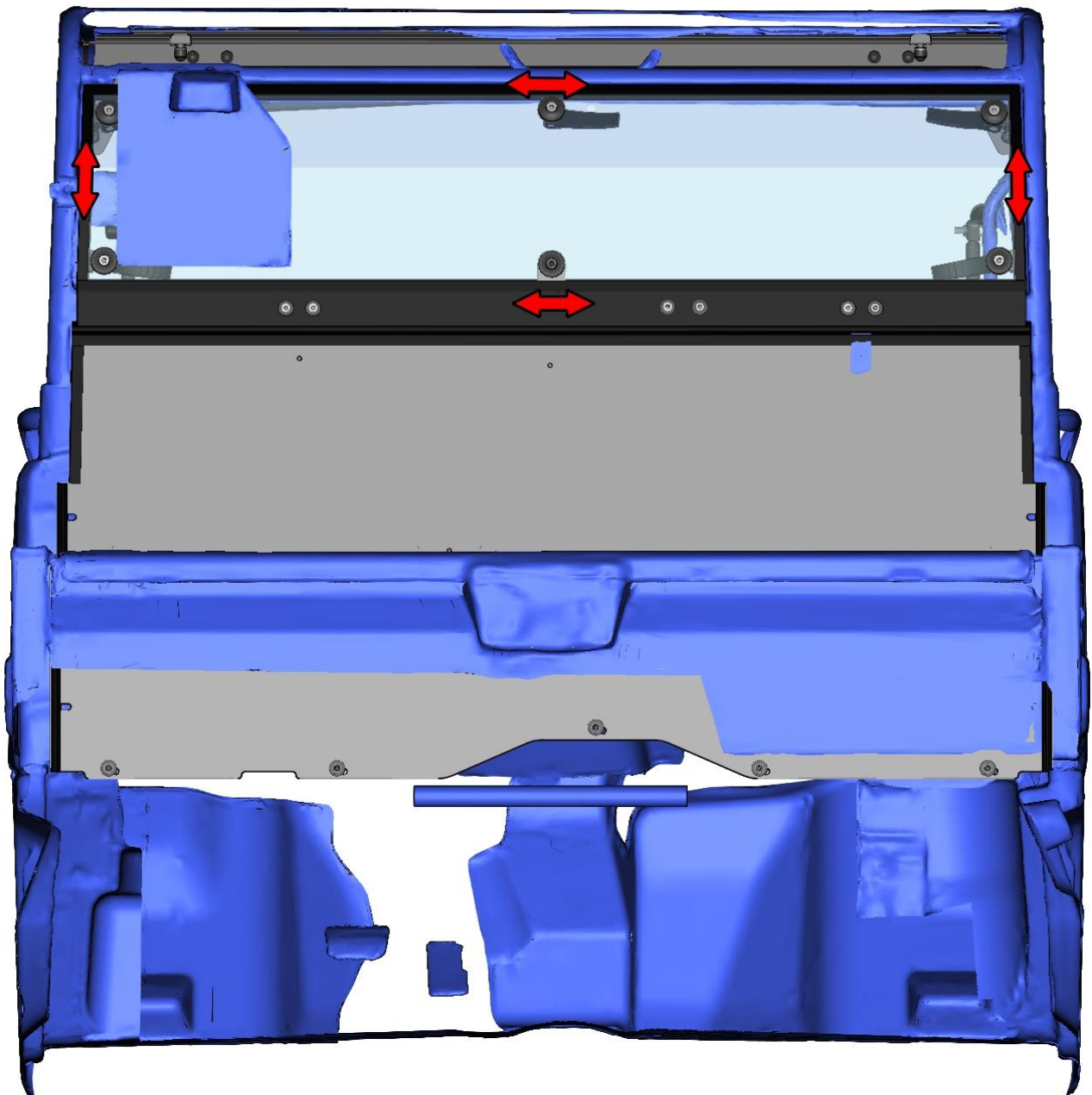

49

Turn the rear upper panel holders to the correct position and tighten the clamping levers.

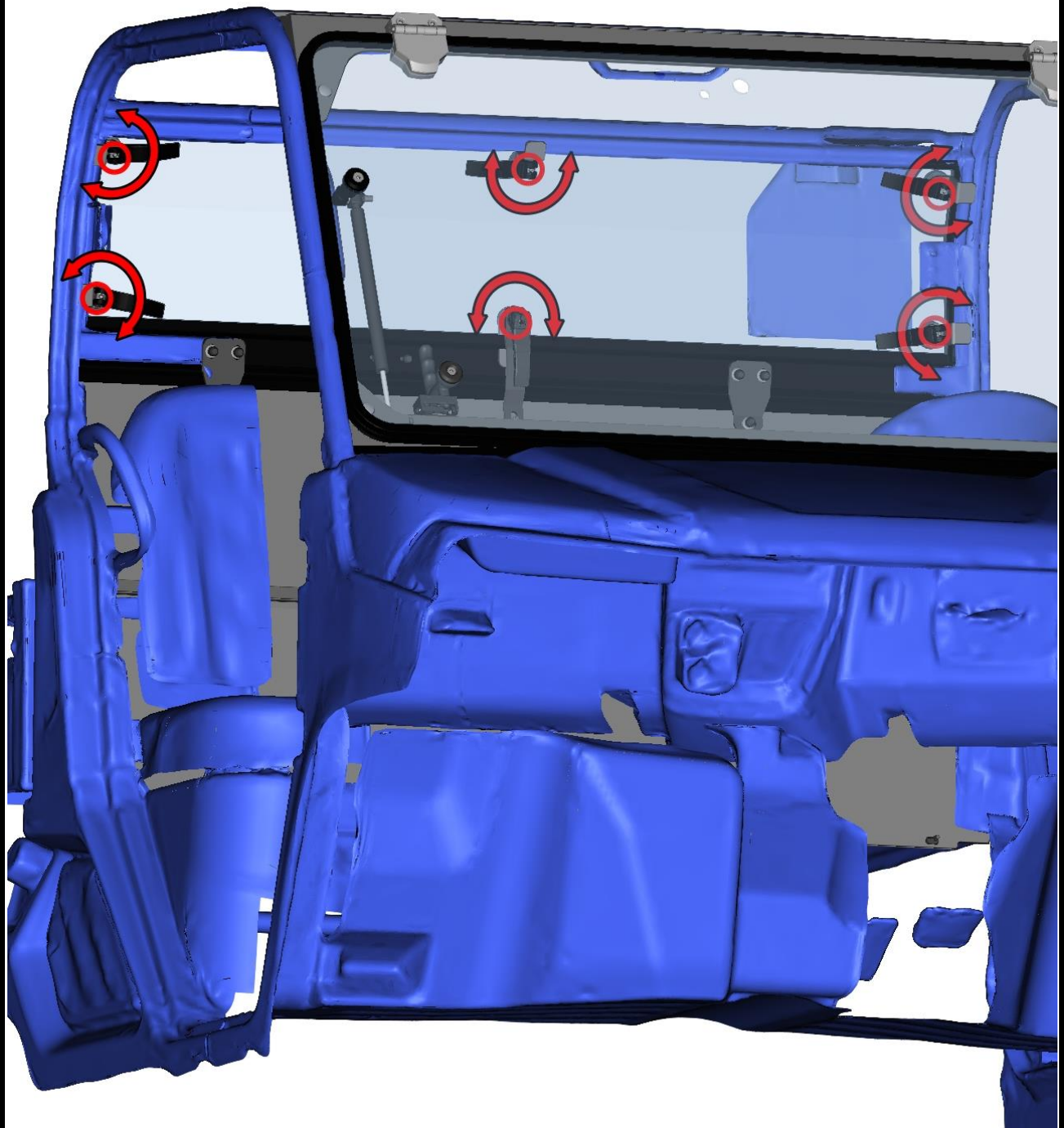

50

Attach the rear upper panel bottom middle holder with included fixing assembly.

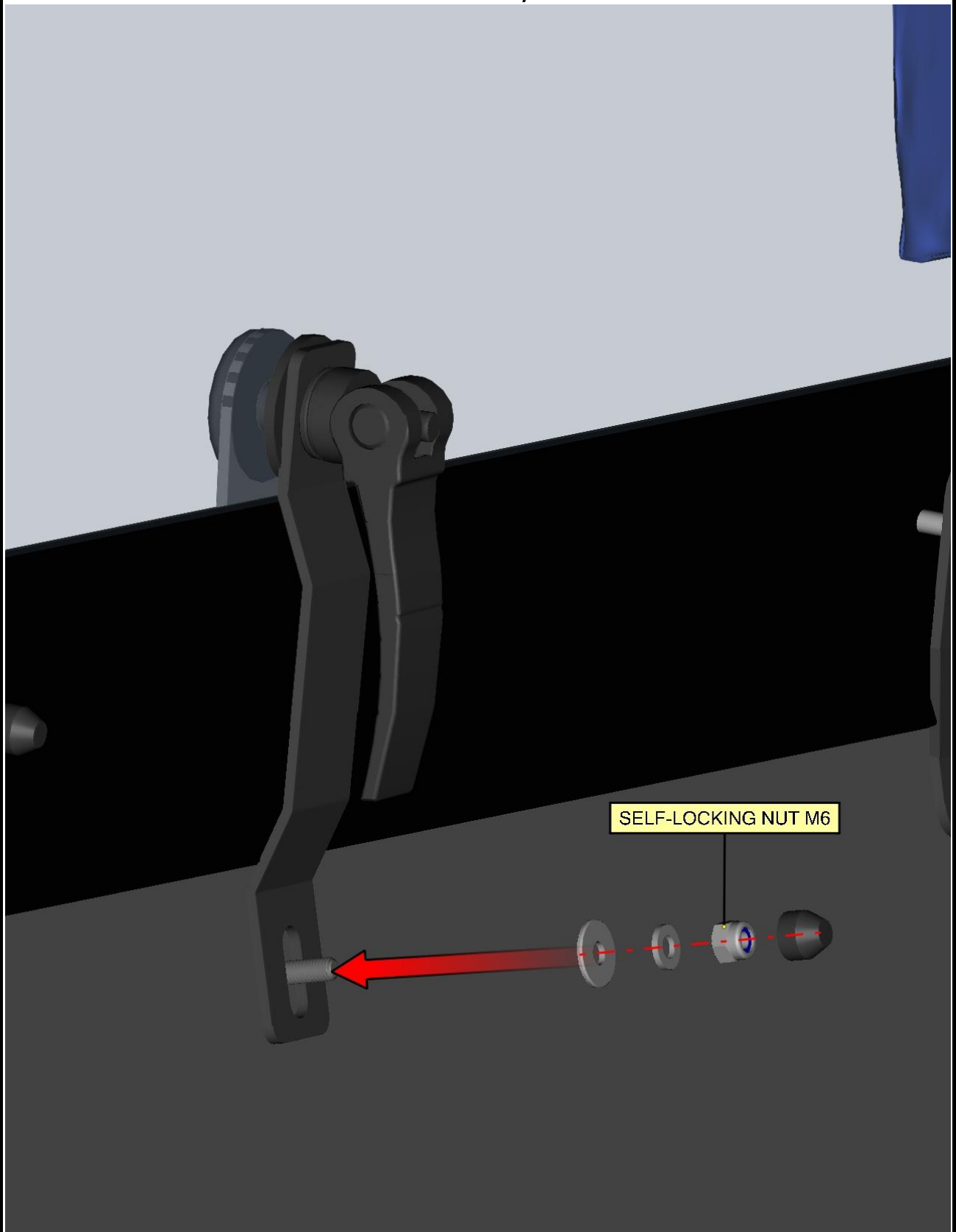

51

ROOF

Place the roof panel onto the UTV roll cage.

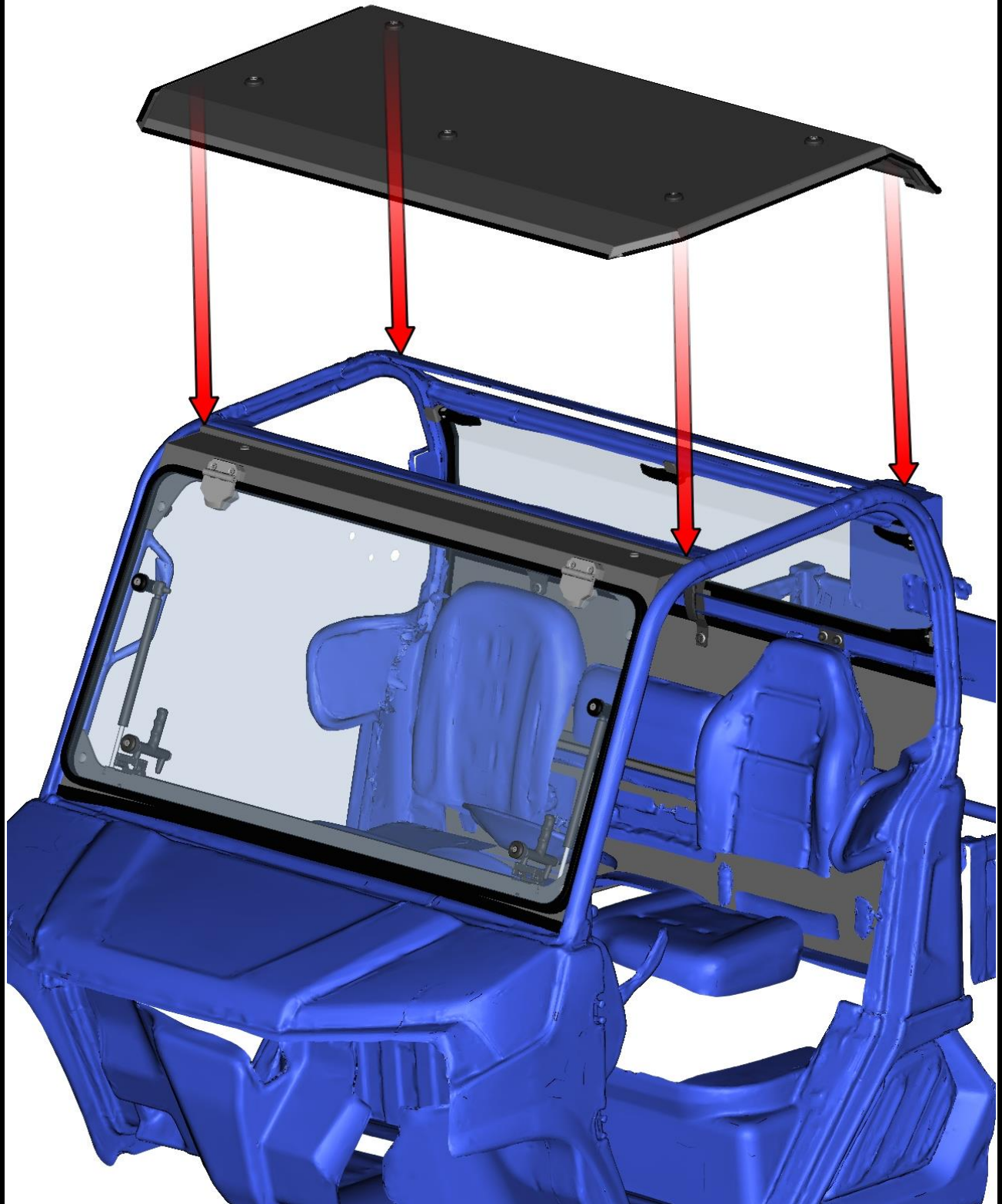

52

Turn the roof panel holders to the correct position and tighten the clamping levers.

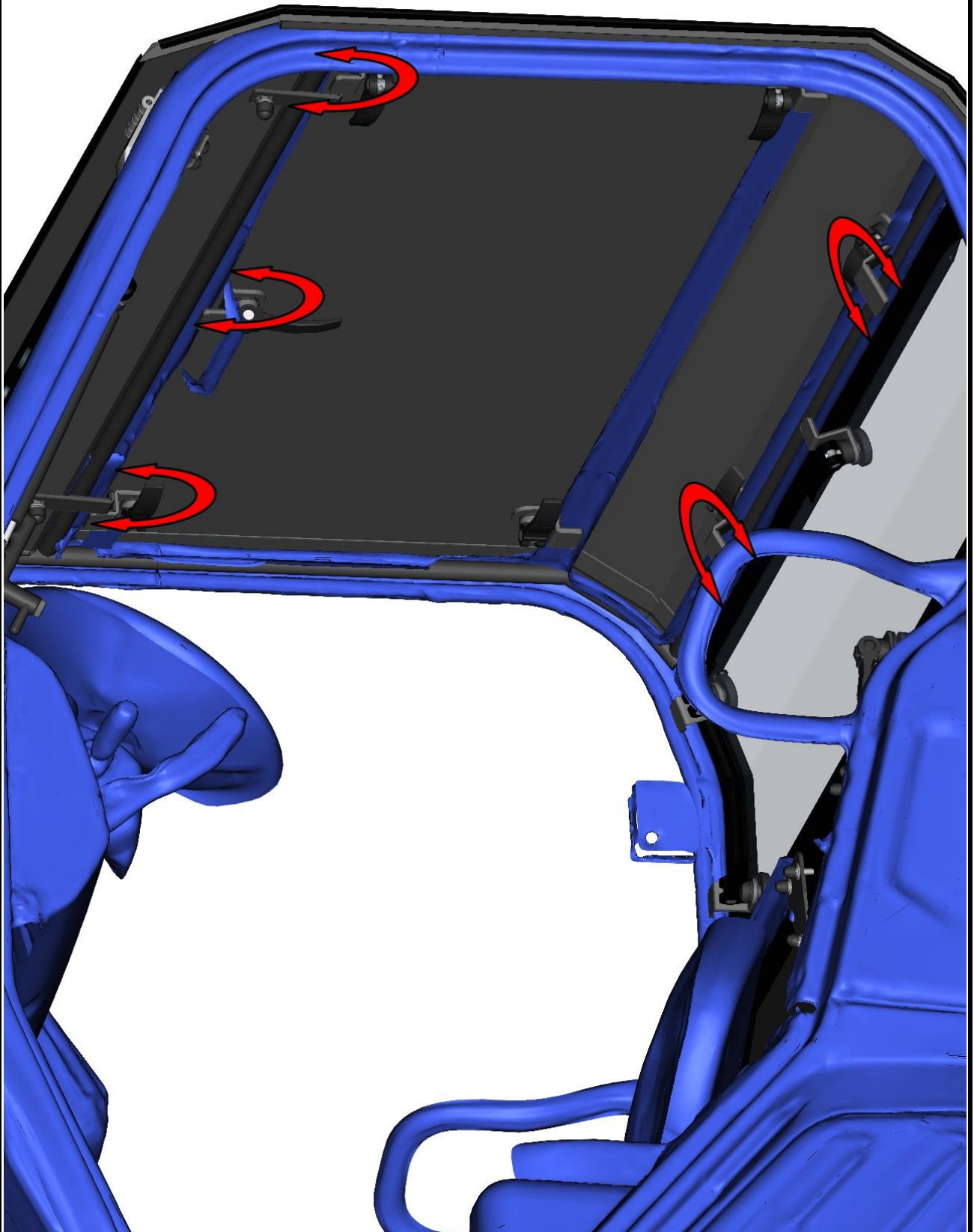

53

LEFT DOOR + RIGHT DOOR

Place the left door hinges onto the UTV body in accordance with original holes.

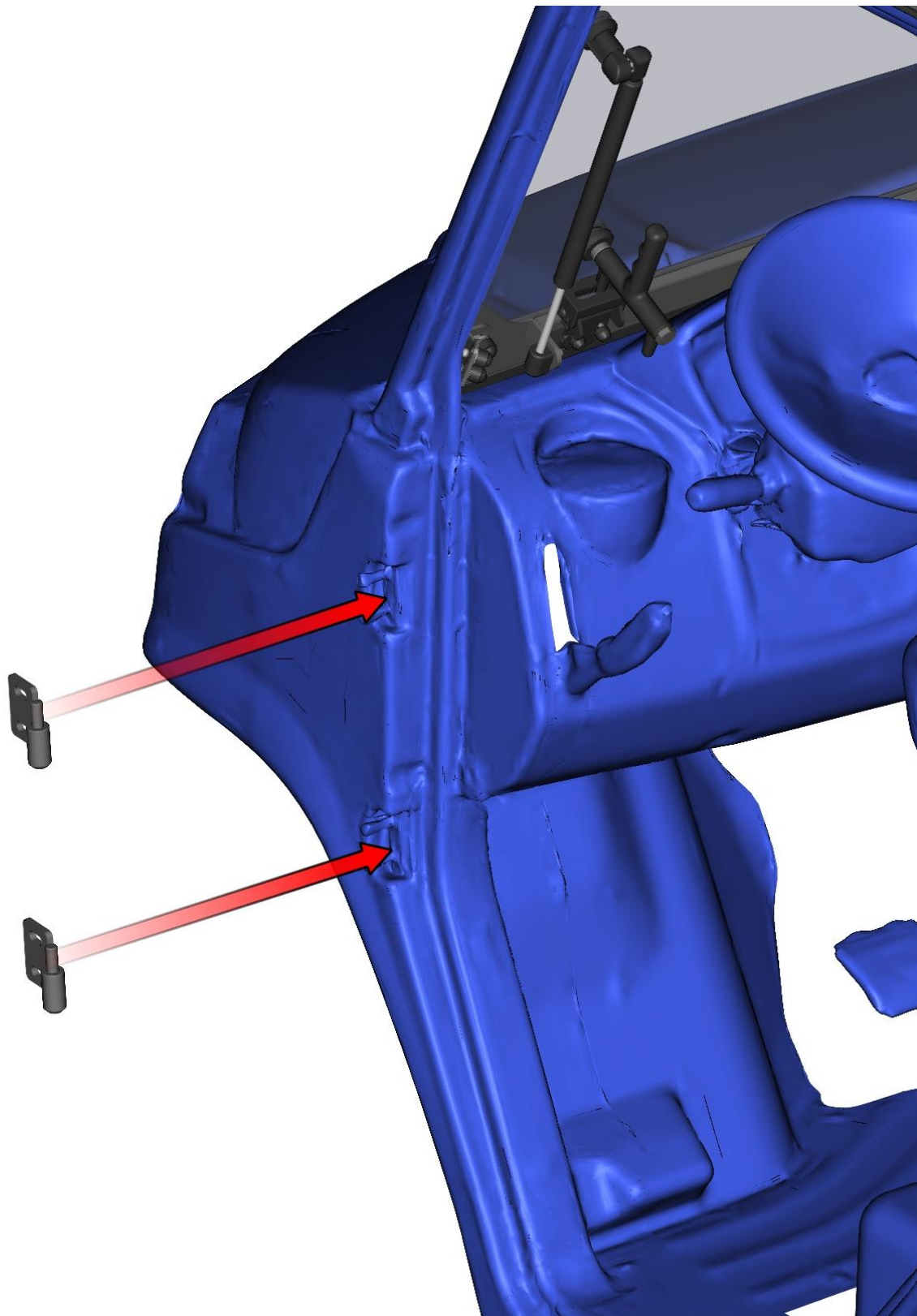

54

Attach the left door hinges with included fixing assemblies.

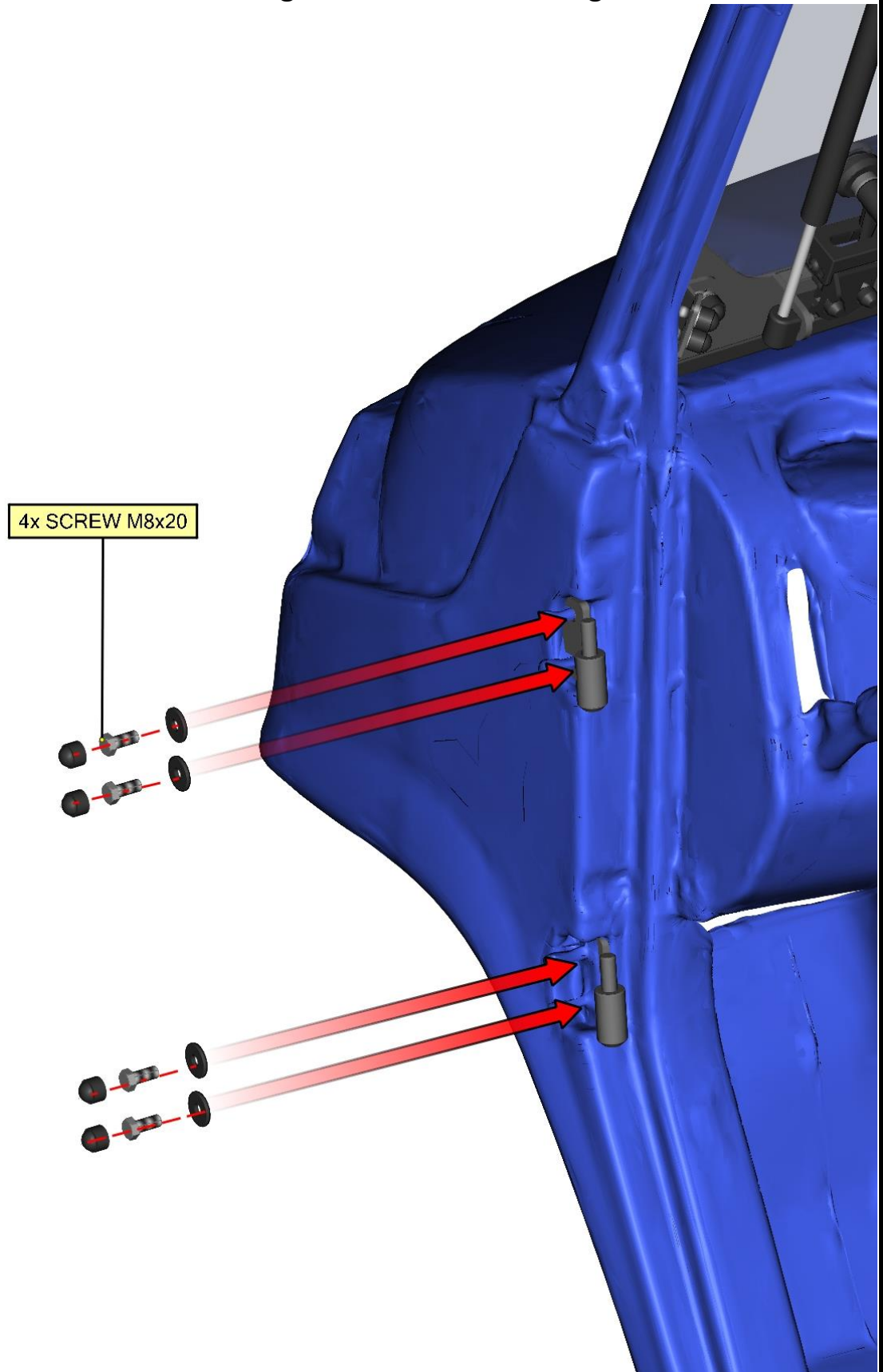

55

Lubricate the left door hinges pins and install the left door assembly onto the hinges pins.

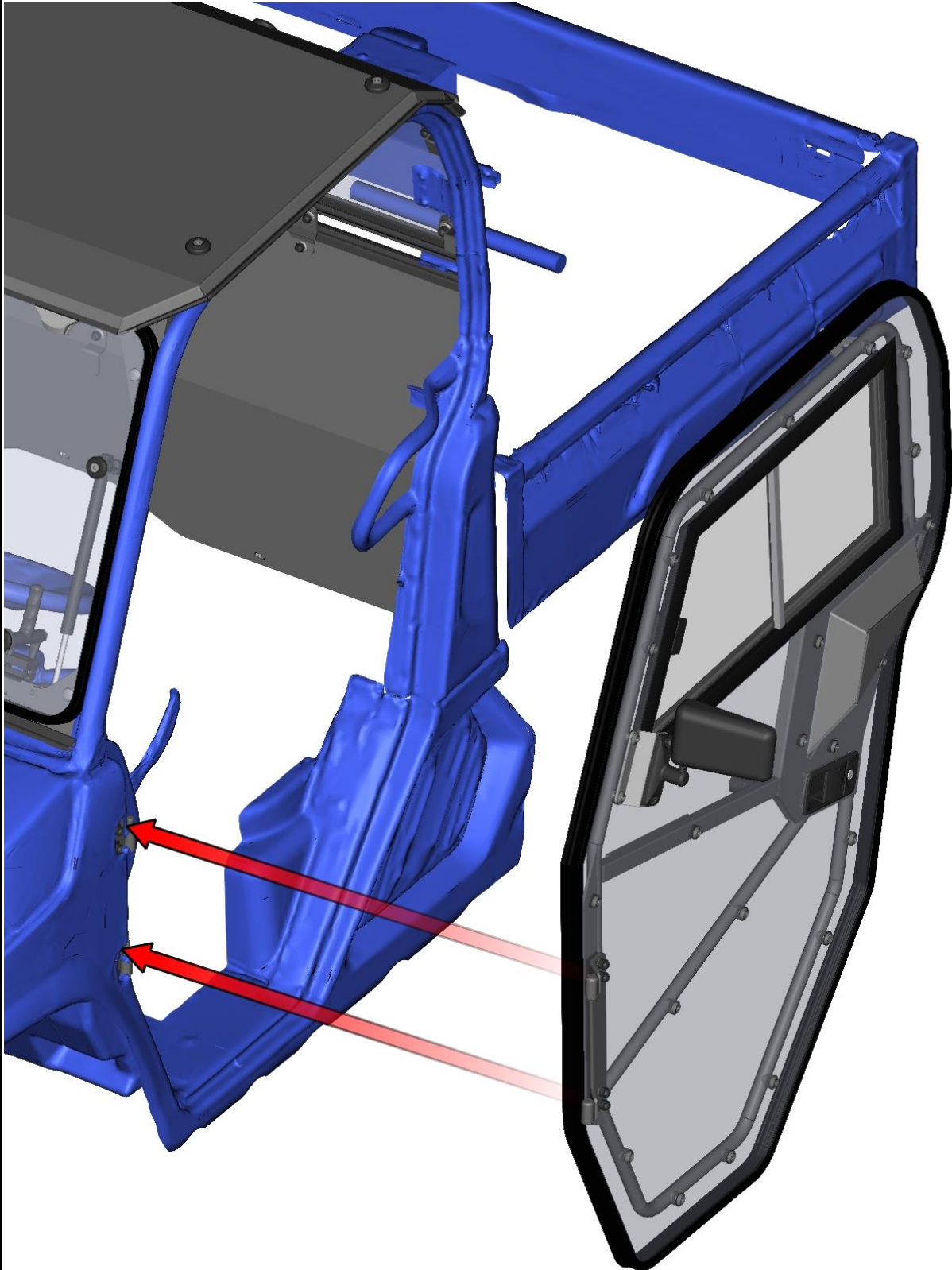

56

Place the left door stop assembly onto the UTV frame in accordance with original hole.

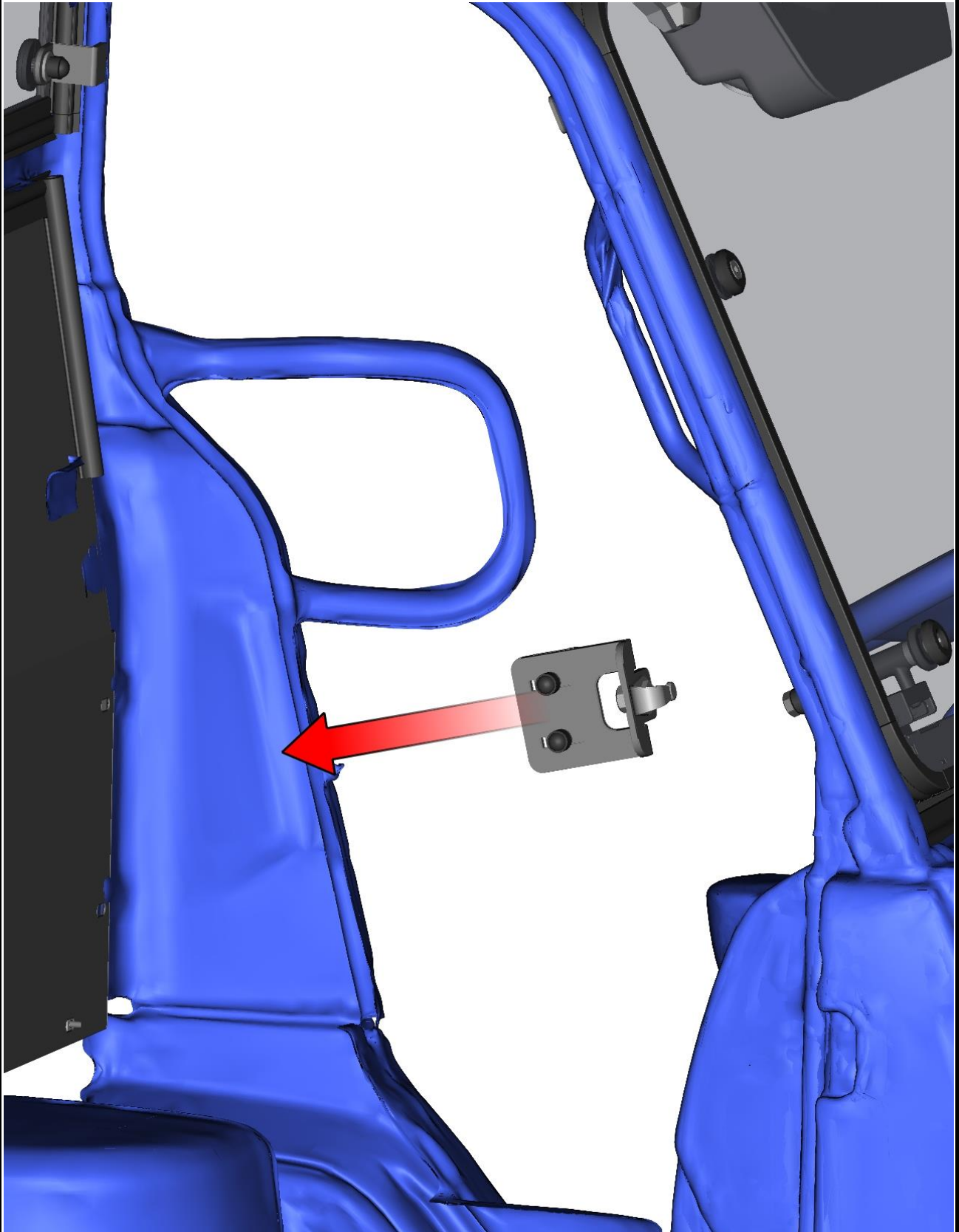

57

Attach the left door stop assembly with included fixing assembly.

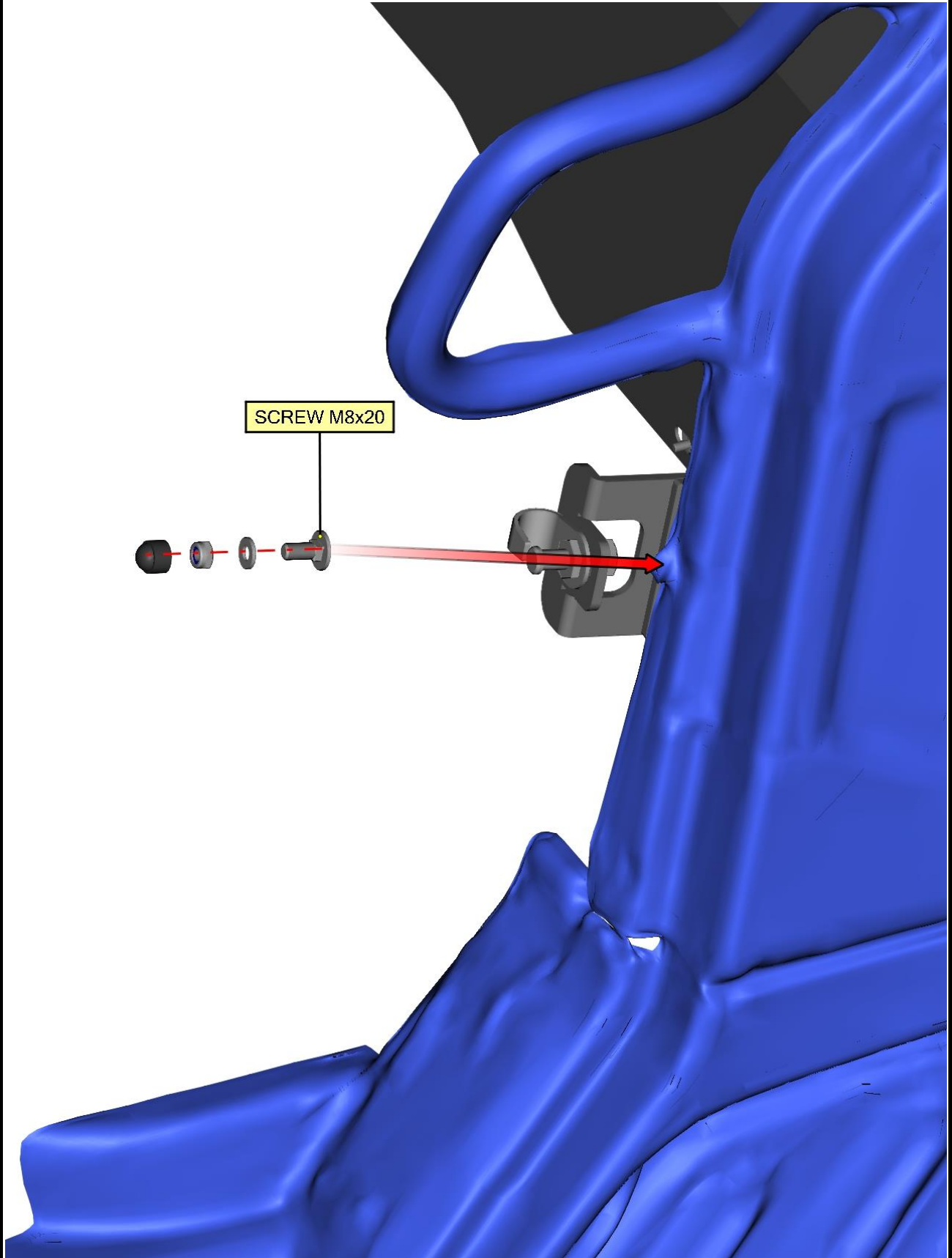

58

Adjust the door stop holder and door stop to the best position with the door. **If you have adjusted the door stop correctly, when you close the door you will hear 2 clear metallic clicks.**

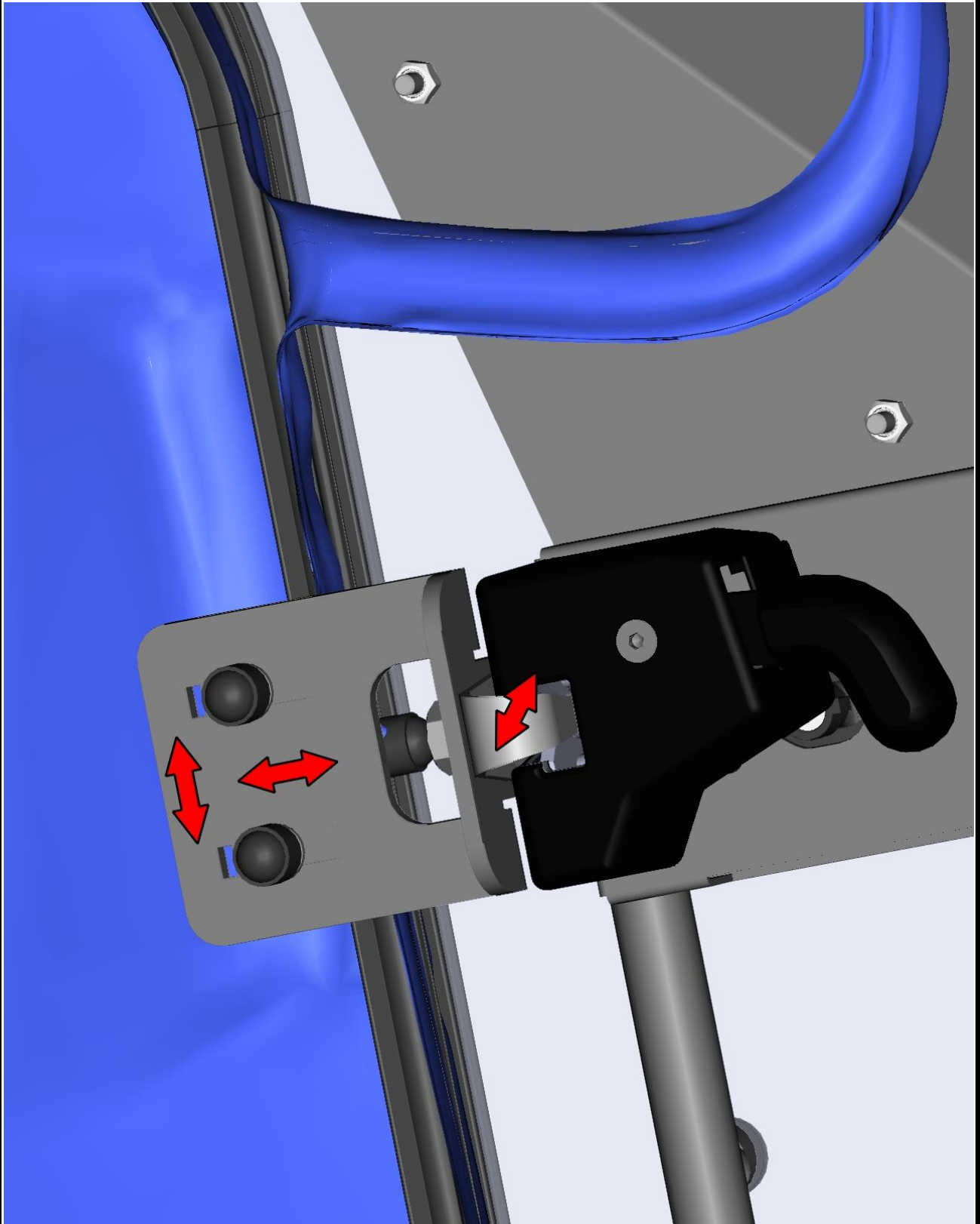

59

Install the door gas spring onto the the gas spring pins.

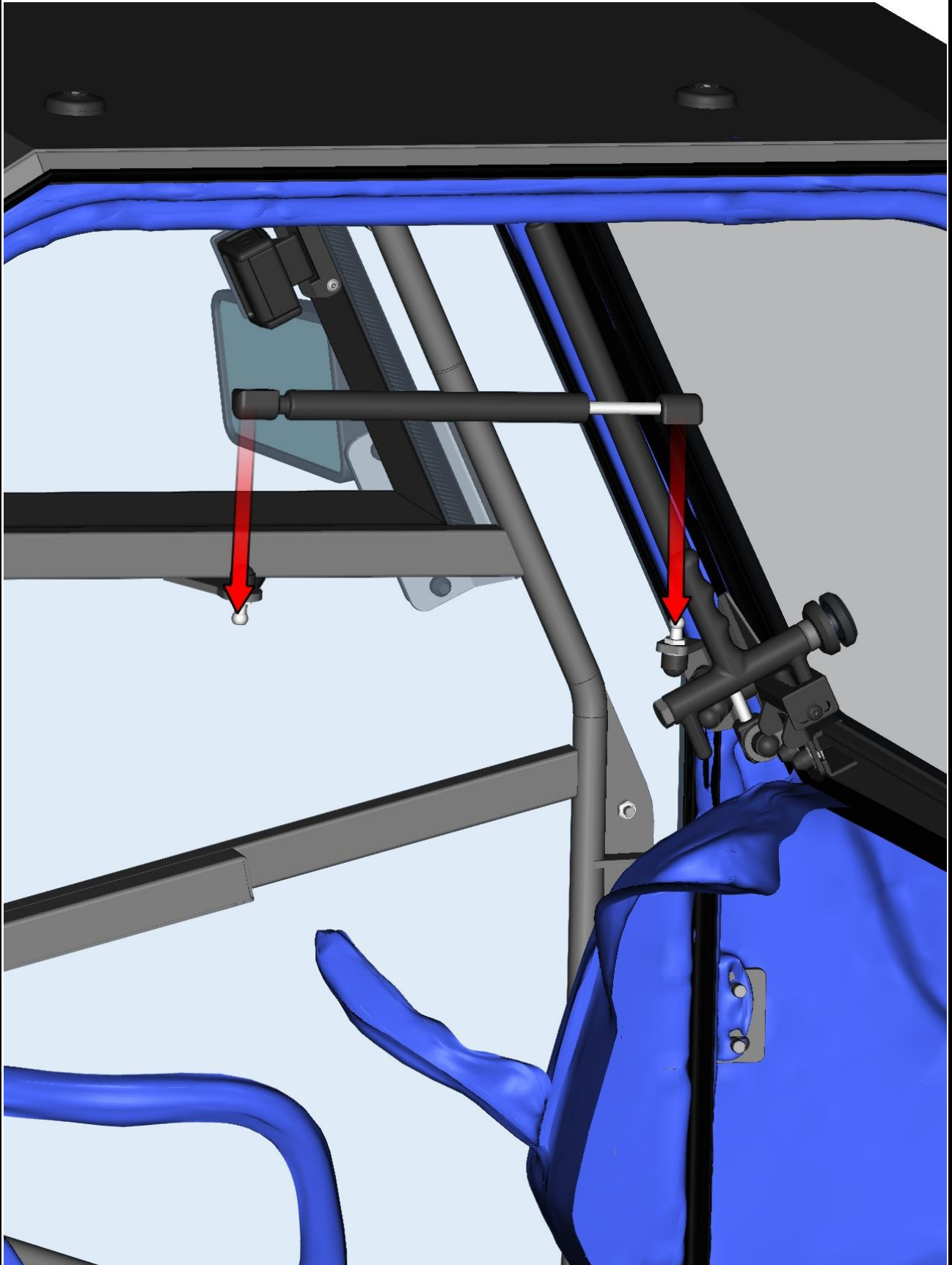

60

Repeat the previous steps with the right door assembly.

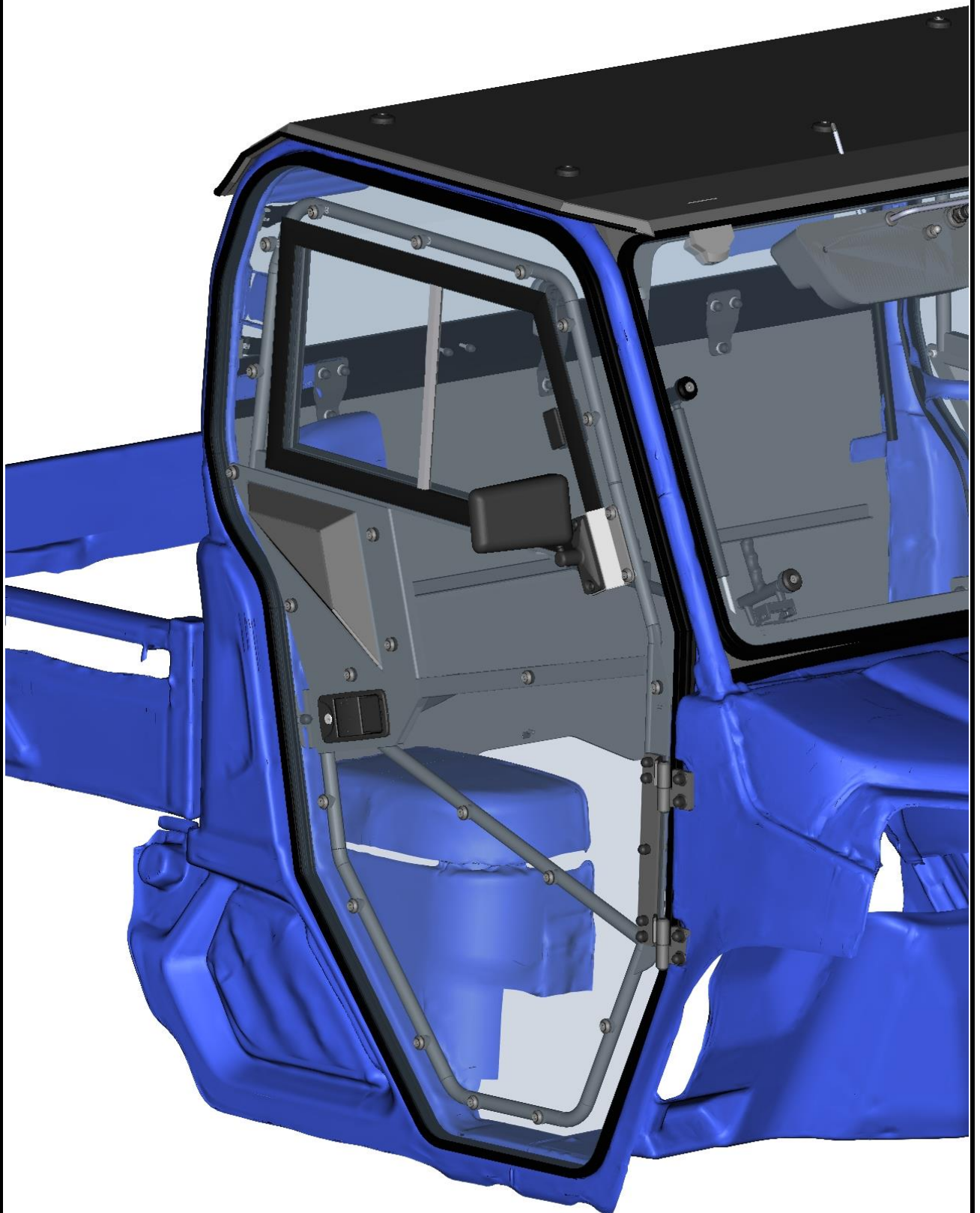

61

BOLT TORQUE

BOLT TORQUE SPECIFICATIONS

GENERAL TORQUE SPECIFICATION TABLE

Use the following torques when special torques are not given. These values apply to fasteners as received from suppliers, dry, or when lubricated with normal engine oil. They do not apply if special graphited or moly disulphide greases or other extreme pressure lubricants are used. This applies to both UNF and UNC threads. Remember to always use grade five or better when replacing bolts.

IMPORTANT: On all PLATED GRADE 8 bolts, reduce torque 15% from listed bolt torque specification.

SAE Grade No.		2				5				8*			
Bolt head identification mark as per grade. NOTE: Manufacturing Marks Will Vary													
Bolt Size		TORQUE				TORQUE				TORQUE			
		Pounds Feet		Newton-Meters		Pounds Feet		Newton-Meters		Pounds Feet		Newton-Meters	
Inches	Millimeters	Min.	Max.	Min.	Max.	Min.	Max.	Min.	Max.	Min.	Max.	Min.	Max.
1/4	6.35	5	6	7	8	9	11	12	15	12	15	16	20
5/16	7.94	10	12	14	16	17	20.5	23	28	24	29	33	39
3/8	9.53	20	23	27	31	35	42	48	57	45	54	61	73
7/16	11.11	30	35	41	47	54	64	73	87	70	84	95	114
1/2	12.70	45	52	61	70	80	96	109	130	110	132	149	179
9/16	14.29	65	75	88	102	110	132	149	179	160	192	217	260
5/8	15.88	95	105	129	142	150	180	203	244	220	264	298	358
3/4	19.05	150	185	203	251	270	324	366	439	380	456	515	618
7/8	22.23	160	200	217	271	400	480	542	651	600	720	814	976
1	25.40	250	300	339	406	580	696	787	944	900	1080	1220	1464
1-1/8	25.58	-	-	-	-	800	880	1085	1193	1280	1440	1736	1953
1-1/4	31.75	-	-	-	-	1120	1240	1519	1681	1820	2000	2468	2712
1-3/8	34.93	-	-	-	-	1460	1680	1980	2278	2380	2720	3227	3688
1-1/2	38.10	-	-	-	-	1940	2200	2631	2983	3160	3560	4285	4827

*Thick Nuts must be used with Grade 8 bolts

62

METRIC BOLT TORQUE SPECIFICATIONS

Size of Screw	Property Class	Course Thread			Fine Thread		
		Pitch (mm)	Pounds Feet	Newton-Meters	Pitch (mm)	Pounds Feet	Newton-Meters
M6	5.6	1.0	3.6-5.8	4.9-7.9	-	-	-
	8.8		5.8-9.4	7.9-12.7		-	-
	10.9		7.2-10	9.8-13.6		-	-
M8	5.6	1.25	7.2-14	9.8-19	1.0	12-17	16.3-23
	8.8		17-22	23-29.8		19-27	25.7-36.6
	10.9		20-26	27.1-35.2		22-31	29.8-42
M10	5.6	1.5	20-25	27.1-33.9	1.25	20-29	27.1-39.3
	8.8		34-40	46.1-54.2		35-47	47.4-63.7
	10.9		38-46	51.5-62.3		40-52	54.2-70.5
M12	5.6	1.75	28-34	37.9-46.1	1.25	31-41	42-55.6
	8.8		51-59	69.1-79.9		55-68	75.9-92.1
	10.9		57-66	77.2-89.4		62-75	84-101.6
M14	5.6	2.0	49-56	66.4-75.9	1.5	52-64	70.5-86.7
	8.8		81-93	109.8-126		90-106	122-143.6
	10.9		96-109	130.1-147.7		107-124	145-168
M16	5.6	2.0	67-77	90.8-104.3	1.5	69-83	93.6-112.5
	8.8		116-130	157.2-176.2		120-138	162.6-187
	10.9		129-145	174.8-196.5		140-158	189.7-214.1
M18	5.6	2.0	88-100	119.2-136	1.5	100-117	136-158.5
	8.8		150-168	203.3-227.6		177-199	239.8-269.6
	10.9		175-194	237.1-262.9		202-231	273.7-313
M20	5.6	2.5	108-130	146.3-176.2	1.5	132-150	178.9-203.3
	8.8		186-205	252-277.8		206-242	279.1-327.9
	10.9		213-249	288.6-337.4		246-289	333.3-391.6



Declaration of Conformity



DFK Cab, s.r.o.

Za Olšávkou 391

686 01 Uherské Hradiště

Česká republika / Czech Republic

Date of Issue: 31-3-2017