

SUPER HARROW



USER MANUAL

INDEX

	Section:		Description:	Page No:
	1		Introduction	3
			HSE Information Sheet	4-8
	2		In the interest of safety: DO NOT	9
	3		In the interest of safety: DO	9
	4		Instructions / Warning Decals	10
	5		Transport Lifting and Storage	11
	6		Operating Instructions and Adjustments	11
		6.1	Attaching to the towing vehicle	11
		6.2	Control box attaching to the towing vehicle	12
		6.3	Float pin on the lifting assembly	12
		6.4	Tine adjustment	13-14
		6.5	Operating Speed	14
		6.6	Harrowing All Weather Arenas	15
	7		Maintenance / Service	16
	8		Specification	17
	9		Parts Diagrams and List	18-20
	10		Logic Manufacturing Product Owner Guarantee	21
			Declaration of Conformity	22

Pro-Harrow Serial Number:

Date of Purchase:

With the purchase of your **LSH200P LOGIC SUPER HARROW** you have made an excellent choice.

This machine should give first class service for a long time, if used correctly, and maintained as described in this manual.

The **LSH200P** uses Einbock™ technology which pioneered organic weeding and plant stimulation. Grass paddocks are rejuvenated by the action of combing, to aerate the soil surface and remove dead grass. It pulls out choking weeds like chickweed, as well as evenly spreading molehills and dried muck.

This system encourages grass growth over a longer season, with healthier grazing conditions and reduced fertilizer costs.

It is equally at home on many all weather surfaces, where maintenance involves levelling and re-incorporating the top surface before rolling, e.g. arenas and gallops.

The 2.0m working width allow fast work rates, feature adjustable tine settings for various conditions and easy transport facility.

The unit is raised and lowered electrically and can be used behind a wide range of vehicles including ATVs, UTVs, tractors and 4 x 4s. (refer to towing vehicle handbook to confirm suitability)

The **LSH200P** is built with high quality components throughout to ensure durability and long life.

If after reading this manual there are any queries, please get in touch and we will be pleased to help.

NORTH & EXPORT
LOGIC MANUFACTURING LTD
Foundry Industrial Estate
Bridge End, Hexham
Northumberland NE46 4JL
Tel: 01434 606661 Fax: 01434 608143
E-mail: sales@LogicToday.co.uk
www.LogicToday.co.uk

SOUTH
LOGIC MH LTD - New Whiteway Works,
Fossecross Industrial Estate
Chedworth. Cheltenham
Gloucestershire GL54 4NW
Tel: 01285 720930 Fax:01285 720840
E-mail: sales@LogicToday.co.uk
www.LogicToday.co.uk

Safe use of all-terrain vehicles (ATVs) in agriculture and forestry

HSE information sheet

Agriculture Information Sheet No 33 (Revision 1)

Introduction

This information sheet gives advice on the safe use of ATVs. It covers the two main types used in off-road working in agriculture, forestry and the land-based industries, namely:

- **Sit- astride ATVs:** Any motorised vehicle designed to travel on four low-pressure tyres on unpaved surfaces, with a seat designed to be straddled by the operator and with handlebars for steering control (see Figure 1). These vehicles are intended to be used by a single operator without a passenger. They may also be referred to as quad bikes.
- **Side-by-side ATVs:** Small utility vehicles in which the driver and passenger sit alongside each other in conventional (ie sit-in) seats (see Figure 2). Most side-by-side vehicles are capable of carrying two occupants in this way; however, some vehicles are equipped with a second row of seating (and can therefore carry four occupants), while others have bench-style seats allowing up to three people to be seated in a row. The majority of side-by-side vehicles have four wheels, although six-wheel and full and partially tracked versions are also available. There is usually a cargo bed behind the seating area. Side-by-side ATVs are sometimes referred to as utility vehicles (UTVs) or rough terrain utility vehicles (RTVs).

ATVs are usually fitted with a tow hitch and are capable of towing a load such as a trailer, a trailed appliance or other equipment.

Hazards

Both types of ATV are designed to cope with a wide variety of terrain types, including steep slopes, but if used outside their safe operating parameters they can very rapidly become unstable. The main causes of serious or fatal injury associated with ATVs are from:

- being thrown off during vehicle overturns or after loss of control;

- collisions with structures, trees, other vehicles etc;
- being trapped/asphyxiated under an overturned machine;
- pedestrians being struck or run over by ATVs.

Contributory factors/underlying causes of accidents and injury with ATVs can include:

- lack of formal operator training and/or experience;
- incorrect/lack of appropriate head protection;
- excessive speed;
- age of the operator;
- carrying a passenger on a sit- astride ATV;
- unbalanced loads or overloading;
- tipping on a bank, ditch, rut or bump;
- loss of control on a steep slope combined with other factors, eg ground or load conditions;
- towing excessive loads with unbraked equipment;
- poor maintenance, eg faulty brakes, incorrect tyre pressures etc.

Control measures for sit- astride ATVs

Training

It is a legal requirement for employers to provide adequate training for employees who use work equipment such as ATVs, and to make sure that only employees who have received appropriate training in their safe use, including the use of any towed equipment or attachments, are permitted to ride them. The same requirements apply to the self-employed.

You can get details of suitable training courses from franchised ATV dealers, manufacturers' websites, EASI (European ATV Safety Institute), the British Off Road Driving Association (BORDA) and through colleges and training providers.

When purchasing a new or used machine from a franchised dealer an industry-led scheme offers customers free training – see 'Useful contacts'.



Figure 1 Example of a sit-astride ATV

Personal protective equipment – the importance of head protection

Sit-astride ATVs are not fitted with either a cab or roll bar, so your only protection is what you wear. Head protection is vital. Many ATV fatalities in the UK have been caused by head injuries. Helmets would certainly have prevented most of, if not all, these deaths. You should always wear a helmet when riding an ATV.

Helmet types suitable for ATV operations, depending on the circumstances, are motorcycle helmets, equestrian helmets, specialist ATV helmets, cycle helmets and mountaineering helmets. All helmets should be manufactured and tested in accordance with the current relevant EN/BS standard, have a chinstrap and be capable of being used with suitable eye protection. The type of helmet chosen should be based on an assessment of the circumstances in which the ATV will be used, eg the types of surface travelled over and anticipated speeds. The harder the surface and higher the speed the greater the degree of protection needed. NB: Forestry helmets and industrial hard hats are not acceptable for any ATV operations.

Wear clothing that is strong and covers your arms and legs. Gloves are useful for protection and handlebar muffs can help to keep hands warm in cold weather for good control of the ATV. Wear sturdy, ankle-covering footwear, eg boots or wellingtons that are strong, supportive and have good wet grip.

Protect your eyes from insects and branches with either a visor or goggles.

Passengers

The long seat on a conventional sit-astride ATV is to allow operators to shift their body weight backwards and forwards for different slope conditions,

a technique known as 'active' riding. It is **not** for carrying passengers. Manufacturers often display a sign on machines prohibiting passengers and this message is also repeated in operator manuals.

Do not carry a passenger in a trailer behind an ATV as any movement can make the machine unstable, particularly with independent rear suspension and trailers with axles wider than the ATV.

Some machines have received European Community Whole Vehicle Type Approval, allowing them to be ridden on the public highway. Some of these machines are designed to carry passengers. Such machines may not be suitable for carrying a passenger when used in off-road situations, eg on sloping ground, as the operator may not be able to use active riding techniques to maintain machine stability. Such machines may not have a locking differential and may not provide an acceptable level of traction to ensure safety in certain off-road conditions.

Before using an ATV you should assess the suitability of the machine for the intended tasks and working environment.

Route planning and stability

Accidents can occur where ATVs are driven on new routes over steep ground for the first time, or are carrying or dragging destabilising loads. When travelling over rough terrain, get to know your own ground and stick to planned routes where possible. Walk new routes if necessary to check for hidden obstructions, hollows or other hazards. Allow for changes in ground conditions and for the destabilising effect of loads or attachments.

Safety checks and maintenance

Off-road use is especially harsh on equipment so it is essential to carry out safety checks and maintenance in accordance with the manufacturer's recommendations. In particular, pre-ride safety checks should always include:

- tyre pressures. These are low, eg typically around 2–7 psi, so even a 1 psi (0.07 kg/cm²) difference in pressure can cause vehicle control problems. Use a gauge that is designed for measuring and displaying low pressures – usually supplied with the ATV;
- brakes and throttle. Check that the brakes give a safe straight stop and that the throttle operates smoothly in all steering positions. Brakes can have a relatively short life in farming or forestry environments and need frequent cleaning, regular adjustment and proper maintenance.

Safe riding methods

On sit-astride ATVs rider positioning is vital to operate them correctly. The position of the rider on the machine needs to be changed depending on the terrain and motion. Riders must have the ability to move and balance the momentum of the ATV with their own body weight. Plan routes (and review the plan if a route is used regularly) to assess risks.

The following advice is no substitute for formal training.

- Most ATVs have no differential and so do not handle in the same way as other machines. This means that when you turn, the ATV tries to keep going in a straight line.
- When cornering on an ATV with no differential, or with the differential lock engaged, where your body weight needs to be positioned depends on how sharp the corner is and on how fast you are going. Correct body position allows you to transfer weight to the outside of the turn through the footrests while maintaining balance with the torso. This lets the inside wheels skid slightly allowing the ATV to make the turn properly.
- You must understand how the transmission system of your machine will affect engine braking for both riding on slopes and recovery of stalled ATVs.
- When riding across a slope, keep your weight on the uphill side of the ATV.
- When going downhill, slide your weight backwards, select a low gear and use engine braking, reducing the need to use the brakes.
- When going uphill, it is important to review the route before starting the climb. Move your weight forwards and maintain a steady speed. It is important to shift your body weight forwards as much as possible. If necessary, stand up and lean forward, keeping both feet on the footrests at all times and always maintain momentum.
- Avoid sudden increases in speed. This is a common cause of rearward overturning accidents, even from a standing start on flat ground where there is good grip.
- Never put your foot onto the ground to stabilise an ATV when riding, but shift your weight across the ATV away from the imbalance.
- Always read the owner's manual.

Trailed equipment and loads

Ensure all riders know the manufacturer's recommended towing capacity and drawbar loading limit. Always operate within these requirements. Remember that your ability to control the ATV by your body movements will be considerably reduced when carrying a load or towing a trailer.

- When selecting trailed equipment look for:
 - over-run brakes;
 - a swivel hitch drawbar;
 - bead lock rims on wheels;
 - a low centre of gravity and a wide wheel track;
 - a long drawbar;
 - attachment points for securing a load.
- Check the weight ratio between your ATV and its trailed load. This needs to be assessed for each operation. As a general guide, on level ground braked trailed equipment can be a maximum of four times the unladen weight of the ATV. For unbraked trailed equipment the maximum should be twice the unladen weight. These loads should be reduced when working on slopes, uneven ground or poor surface conditions. Follow the manufacturer's advice for your particular machine.
- Weight transfer is also important. Stability and resistance to jackknifing is improved if some load is transferred onto the ATV's drawbar. Approximately 10% of the gross weight of the loaded trailer is recommended, but this should not exceed the manufacturer's drawbar loading limit. Remember that weight transfer can change dramatically when you start going up or down hill.
- When selecting mounted equipment, make sure it is within the manufacturer's approved weight limit, with a low centre of gravity and controls which are easy to operate but do not create a hazard. Where equipment is added to one end of the machine, add ballast at the other end to maintain stability.
- Loads carried on racks must be well secured, eg with ratchet straps, and be evenly balanced between the front and rear, except where they are deliberately altered to aid stability when going up or down a slope. Maximum weights that can be carried should be specified in the operator's manual and may be marked on the machine. These should not be exceeded.
- Only tow a load from the hitch point. Loads towed from other points, such as the rear rack, have caused sudden rear overturning even on slight slopes or with slight acceleration. Do not use ropes or chains to drag a load; they can become caught on a wheel. This may lead to entanglement with the brake cable, causing unexpected braking.

Using sprayers

- Sprayers should be fitted with an induction hopper unless the filling point is less than 1.5 m from the ground and within 0.3 m from the edge of the sprayer. A separate clean water tank for washing must be provided containing at least 15 litres of clean water and a tap that allows the water to run without being continuously pressed.
- When buying a sprayer look for a low centre of gravity and internal baffles to reduce liquid surge and improve stability when turning on slopes.

- ATVs should only be used with rear-mounted spray booms or other equipment that reduces the risk of pesticide exposure to the operator.
- Do not hold a spraying lance while riding your ATV as you need two hands for safe control.

Accessories

Beware of the potential dangers of accessories which are not approved by manufacturers, eg home-made gun racks and boxes. Either use accessories supplied/approved by manufacturers or seek their advice as to the suitability of those sourced elsewhere.

Any weight added above the centre of gravity will decrease the ATV's stability, eg feed hoppers/dispensers fixed above the rear rack.

Children

- Never carry a child as a passenger. It is illegal and will reduce your ability to control the ATV.
- Children under 13 years old are prohibited from using an ATV for work. Over-13s should only ride ATVs of an appropriate size and power after formal training on a low-power ATV.
- Children under 16 years old are prohibited from using most adult-sized machines. Check and adhere to the manufacturer's minimum age recommendations for your ATV; this information may be displayed on the machine and in operator manuals. Similar restrictions apply to side-by-side machines.
- The ratio of a child's weight to that of the ATV is significant, as weight transfer is the key to safe handling.
- In the event of an overturn, a child may be crushed by the weight of an adult-sized ATV. They may be unable to lift it off unaided.

Roll-over protective structures (ROPS)

- HSE's current advice is that roll-over protective structures (ROPS or crush protection devices) are not recommended for sit- astride ATVs. Research has shown that they may lead to an increased risk of injury in the event of an overturn by either preventing the operator from separating from the machine or striking the operator as the machine overturns.
- Lap straps/seat restraints should not be fitted. They prevent active riding and would be potentially lethal without a full cab or roll cage.
- Weather cabs on sit- astride ATVs restrict a rider's ability to jump clear in an overturn. The rider is likely to be crushed within the cab unless it is strong enough to withstand the forces involved. Carefully assess the risks for your particular

conditions of use before fitting any such structure and consult the manufacturer for information.

Side-by-side ATVs

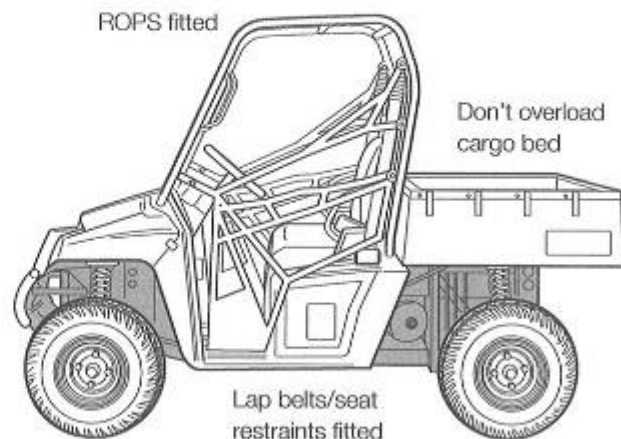

Figure 2 Example of a side-by-side ATV

Utility side-by-side ATVs are used for many of the same purposes as tractors and designed for similar work activities, ie off-road use on difficult terrain. They have conventional sit-in seats, and the main controls comprise a steering wheel and pedals. The driver does not need to use weight transfer to steer or to control stability. Nevertheless, the correct distribution of weight on-board the vehicle is important, particularly when carrying a load or on uneven surfaces. Loads carried on the cargo bed should not exceed the recommended weight and should be secured against movement.

Training

The legal requirements for training are the same as for the sit- astride ATVs.

ROPS and seat belts

The requirements for these machines are quite different to those of sit- astride ATVs:

- To reduce the risk of injury in the event of a roll-over or other incident, side-by-side vehicles require lap belts/seat restraints as well as ROPS that essentially form a protective structure around the seating area. The compartment is usually open, although some vehicles are fitted with a windscreen and/or side doors. The driver and all passengers should be protected by ROPS and wear lap belts.
- Where a machine is amphibious and used on deep water as opposed to marshland, then the seat restraints (and possibly ROPS) could increase the

overall risk rather than reduce it. In this case, do not use seat restraints while on the water. Assess the risk from the roll frame according to its design and the likelihood of trapping the occupants if the machine should sink.

© *Crown copyright* If you wish to reuse this information visit www.hse.gov.uk/copyright.htm for details. First published 05/99.

Parking

If you have to park on a slope, always park across it unless it is too steep. Accidents have occurred when machines have run down slopes because of poor brake maintenance or application, particularly while they are being loaded and movement or the increase in weight has set the machine in motion.

Useful contacts

EASI®, the European All-Terrain Vehicle Safety Institute, is a not-for-profit organisation which provides safety training courses for ATV riders.

EASI's UK operation is sponsored by a number of ATV manufacturers and delivers a programme of specialist ATV training courses which are designed to improve rider skills, safety levels and awareness of the capabilities of ATV machines.

Buyers who purchase a new or used ATV from one of these manufacturers via an authorised UK dealer are eligible for **free** or highly subsidised training, subject to qualifying terms, conditions and availability. See www.quadsafety.org/ for details.

Training is also available from other organisations, such as the British Off Road Driving Association (BORDA). See www.borda.org.uk for details.

Further information

For information about health and safety, or to report inconsistencies or inaccuracies in this guidance, visit www.hse.gov.uk/. You can view HSE guidance online and order priced publications from the website. HSE priced publications are also available from bookshops.

This guidance is issued by the Health and Safety Executive. Following the guidance is not compulsory, unless specifically stated, and you are free to take other action. But if you do follow the guidance you will normally be doing enough to comply with the law. Health and safety inspectors seek to secure compliance with the law and may refer to this guidance.

This leaflet is available at:
www.hse.gov.uk/pubns/ais33.htm.



This symbol means **WARNING** or **CAUTION**. Personal safety or damage will be at risk if these instructions are ignored. Most accidents are caused by neglect or carelessness. Avoid needless accidents by following the safety precautions listed below.

2

IN THE INTEREST OF SAFETY: DO NOT

DO NOT – Operate the LSH200P unless you have read this entire manual.

DO NOT – Operate the LSH200P if any part of the harrow is defective. replace any parts before use.

DO NOT – Touch moving parts.

DO NOT – Reverse with the harrow in the work position.

DO NOT – Never carry passengers.

DO NOT – Exceed sensible towing speeds. (Max 20mph)

3

IN THE INTEREST OF SAFETY: DO

DO – Follow all guidelines given by Logic Manufacturing Ltd.

DO – Attach the LSH200P to a suitable towing vehicle.

DO – Follow all manufacturer's service instructions.

DO – Be aware of travelling conditions – Do not exceed sensible speeds.

DO – Follow all safety instructions in this manual.

DO – Make sure all persons are at a safe distance when operating the LSH200P, especially when operating in areas used by the public.

DO – Make sure all nuts bolts and fittings are secure before using and check at regular intervals during operation.

DO – Avoid excessively steep slopes.

DO – After hitting an obstacle, stop the machine and check for damage.



The above decals should be located on your LSH200P. If any of the above decals are not located on your LSH200P or are damaged in any way contact Logic for some replacement decals before use.

5 TRANSPORT LIFTING AND STORAGE

Ensure the vehicle used to lift and transport the harrow has the necessary lifting and loading capacity. Follow all vehicle manufacturer's guidelines for lifting.

When lifting the LSH200P for transporting/ delivery purposes always ensure to locate the lifting straps on each of the four corners ensuring the straps/chains are all the same length before lifting, or if using forklift tines ensure the harrow is secure on the tines before lifting.

6 OPERATING INSTRUCTIONS AND ADJUSTMENTS

The LSH200P is designed to give safe and dependable service if operated according to instructions and intended use.

Read and understand this manual before operating the unit, as failure to do so could result in personal injury or equipment damage.

INITIAL CHECK

Make sure that all nuts, bolts and fittings are securely fixed, and that all packaging materials e.g. wire bands, tape etc have been removed.

6.1 ATTACHING TO THE TOWING VEHICLE

The LSH200P is simply attached by the 50mm ball coupling

The Tine bed is raised and lowered from the transport to work position electrically by the electric actuator. This is shown in figure 1.

Once attached to the towing vehicle take note of the width of the LSH200P compared to the width of the vehicle.

If the vehicle is fitted with wing mirrors they should be adjusted to allow the user to see the outer most point of the LSH200P from the driving seat.

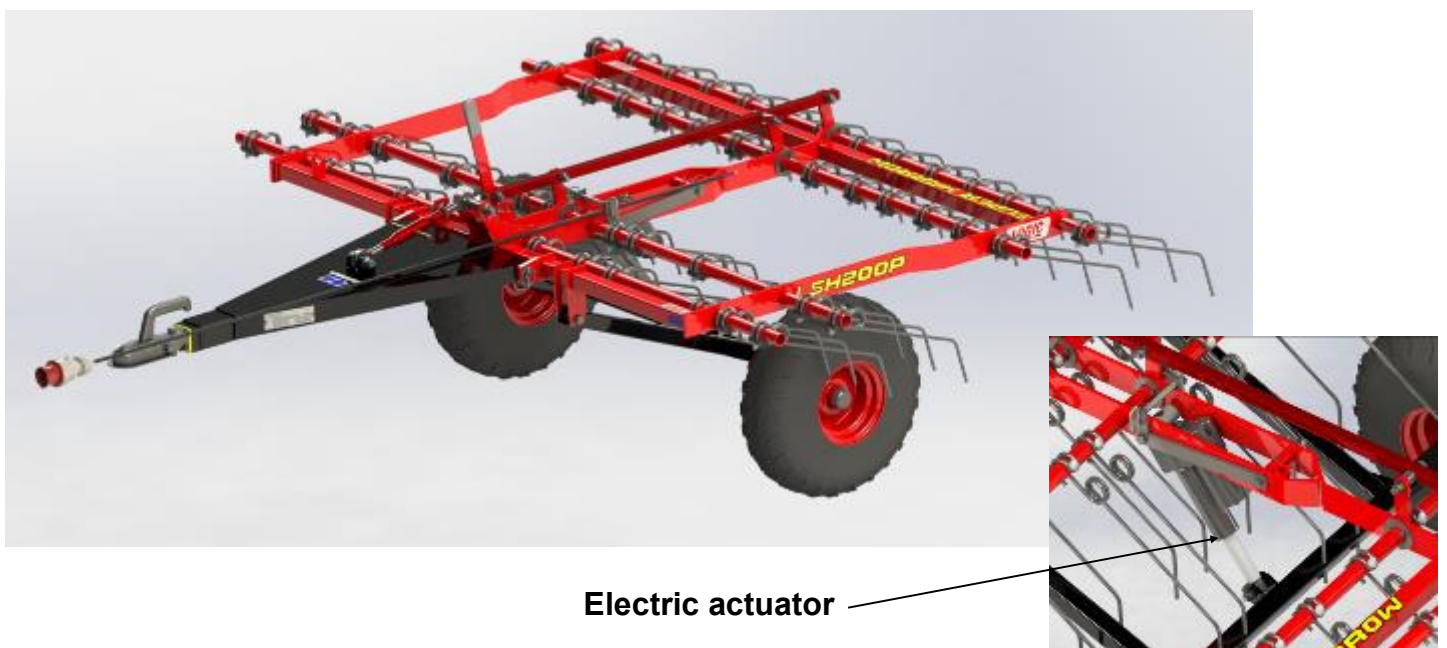

Figure 1

6.2 CONTROL BOX ATTACHING TO THE TOWING VEHICLE

- a. Remove the control box kit from its packaging and lay out on the ground.
- b. Take the control box and mount it to the towing vehicle in a reachable place from the operator.
- c. Route the power supply cable to the towing vehicle battery. Ensure the routing does not get close to any hot areas on the towing vehicle e.g. exhaust.
- d. Route the power socket cable to the rear of the towing vehicle and mount the socket as centrally as possible. The socket comes fitted with clips as standard to attach to an ATV rear rack. These can be removed for mounting to ATV or 4 x 4. Ensure the routing does not get close to any hot areas on the towing vehicle e.g. exhaust.
- e. Connect the harrow plug to the socket and check the harrow lifts up and down.

The control box comes with excess cable length to allow it to be fitted to a UTV or 4 x 4 easily.

6.3 FLOAT PIN ON THE LIFTING ASSEMBLY

The LSH200P will be supplied with the float pin inserted in the lifting assembly to stop the axle floating/ dropping. The pin should be removed for harrowing and only reinserted if the harrow is to be lifted off the ground for transport. The pin is shown below in figure 2

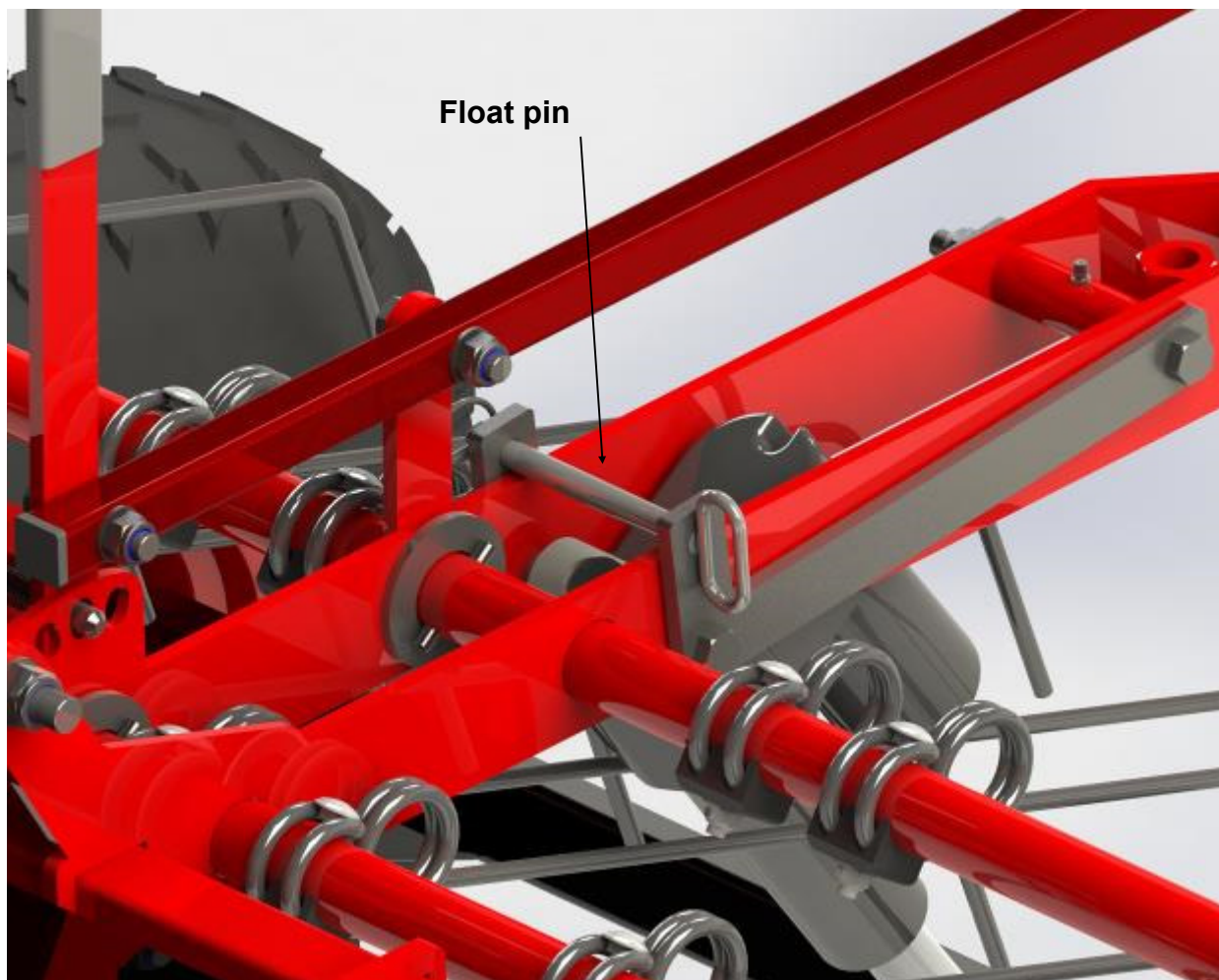

Figure 2

6.4 TINE ADJUSTMENT

The aggressiveness of the tines on the ground is controlled by the adjustment handle located at the front of the machine. See figure 3.

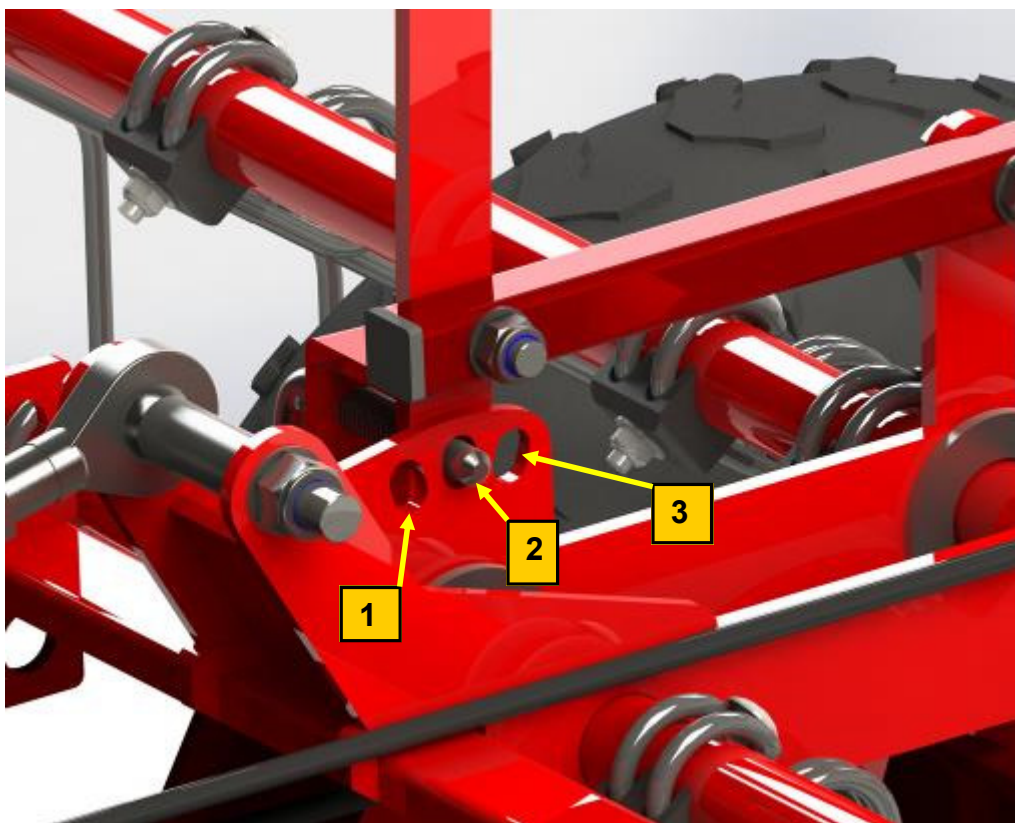

Figure 3

The tines have three settings which are designed to give the optimum effect on the ground with the users desired vehicle.

The more vertical the tines are, the more aggressive their action will be on the ground.

Setting 1 is the light setting and is for light harrowing.

Setting 2 is the mid setting and is for moderate harrowing

Setting 3 is the highest setting for aggressive harrowing

The tine angle difference between settings is shown below in figure 4.



Setting 1



Setting 2



Setting 3

Figure 4

ADJUSTING THE TINES

1. Lift the harrow into its transport position.
2. Pull out the spring locking pin located on the adjustment handle at the front of the machine.
3. Move the adjustment handle to the desired setting.
4. Ensure that the spring pin locks the tines in the desired setting.
5. Lower the machine into the work position.
6. Adjust the drawbar turnbuckle to level the machine before use.

Points to consider when setting the aggressiveness

- a) The type of operation being carried out, horse muck dispersal, thatch removal, etc. requires an aggressive setting. All weather surface maintenance, crop weeding etc, requires less aggression.
- b) The type of soil
- c) The type of crop or sward conditions
- d) The speed of operation.
- e) The power of the towing vehicle.

6.5 OPERATING SPEED

FORWARD SPEED

In general the LSH200P works best at speed in order to create a vibrating effect with the tines. Start off at a slower speed and then increase gradually to find the optimum working speed for the towing vehicle.



NOTE: When using an ATV to harrow it is very easy to overheat the engine due to the constant drag and slower operating speeds than normal. Often it is better to reduce the power requirement by reducing the tine aggressiveness, speed up slightly and go over the same area twice.

We recommend a minimum requirement of 500cc for an ATV engine and the most aggressive setting should only be used if conditions allow or with a larger ATV or a more powerful towing vehicle.

The machine should never be driven at excessive speeds which could cause bouncing, resulting in uneven harrowing and danger to the operator and any personnel nearby.

MOVING FROM ONE SITE TO ANOTHER

When moving from one area to another simply raise the tines into the transport position and proceed with care.

6.6 HARROWING ALL WEATHER ARENAS

Before beginning work the surface needs to be inspected to understand the construction layers of the surface and to locate the depth of any membranes that may have been incorporated. These must be avoided at all costs, but there is usually enough depth above the membrane to allow re-incorporation of the upper materials.

Tine depth control can be achieved by fitting the **LSH201-20A** depth stop kit. The depth stop screws into the main frame of the harrow above the axle. The further the stop is screwed in the less deep the harrow tines will go. The depth stop is shown in figure 5.

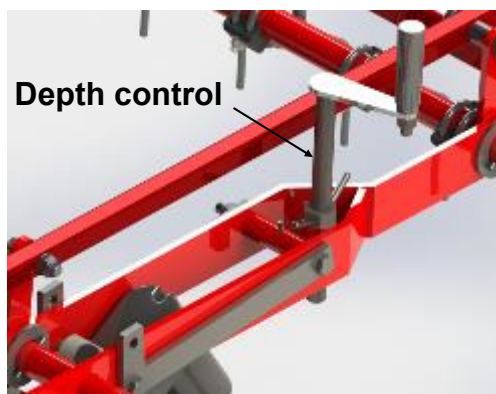

Figure 5

It is always wise to begin with the tines in the least aggressive setting. Move the adjustment handle to hole 1 – see section 6.4, page 13. Lower the harrow onto the surface and set off at a relatively slow speed to see how the tines are interacting with the surface materials. If there is little disturbance and minimal re-incorporation happening then lower the tines another hole and try again, making sure the tines are not too deep to cause damage.

Once you are happy with the action the tines are having at speed, our recommendation is to follow the following sequence of passes to fully cover and level the arena.

Move any obstacles such as jumps to one side to ensure the entire arena is levelled. The surface can be disturbed the most where a horse has been jumping and turning so it's vital the jump areas are harrowed.

(See figure 6)

Consider which direction you want to finish the arena, then work backwards with passes at an angle to the previous pass.

STAGE 1: Set off at an angle approximately 45 degrees from the side of the arena. This will cross any well worn routes the horse will have travelled if working the length of the arena.

STAGE 2: The second pass should be at 45 degrees to the first pass and 90 degrees to the side of the arena so that there is maximum levelling of the first pass. This should be carried out at approximately 6-8 mph to create a turbulence between the tines which will re-incorporate the surface components.

STAGE 3: The next pass should be in the direction you wish to leave the arena looking, prior to any display or exercise work. In this case the harrow can be reversed into each corner to rake out the surplus material then the whole arena harrowed parallel to the longest side, with the final pass at each end to level the turning marks.

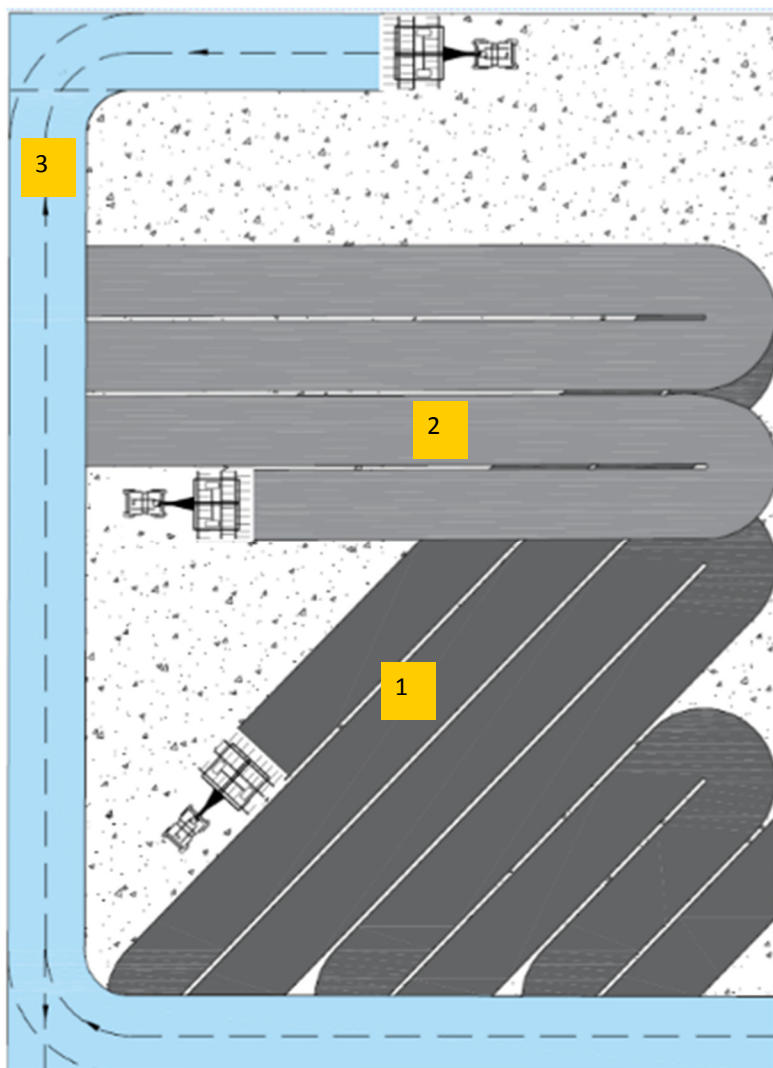

Figure 6: 3-stage harrowing technique

SERVICE SCHEDULE

	DAILY	WEEKLY	MONTHLY
Check tyre pressures	●	●	●
Check condition of tyres	●	●	●
Visual check to ensure nothing is loose	●	●	●
Check all nuts and bolts	●	●	●
Oil the coupling mechanism and check for wear			●
Grease lift assembly bushings		●	●

TYRE / PRESSURE

Tyre pressure for: Carlisle, trail wolf AT 20 x 7 - 8 (Min 4 Psi Max 10 Psi)



DO NOT exceed recommended tyre pressures.

Remember that temperature affects pressures: in cold weather, the pressure needs to be higher than in higher temperatures.

Never adjust the pressure immediately after driving, because driving heats up the tyres. There are many individual causes of tyre troubles. However, the three abuses which will cause most problems, and the greatest costs, are under-inflation, overloading and speeding. When you check the tyre pressures also look for bumps and bulges in the side of the tyre or tread. Check the tyres for cuts, slits or cracks, nails or foreign objects embedded in the side of the tyre or tread. Check the tread for excess wear. Replace or repair any defect or fault with tyres before use.

SWIVEL HITCH HOUSING

Check coupling for signs of damage or wear, swivel the coupling 360 degrees and check that the bushes are not too worn. Replace any worn or damaged parts.

Oil the 50mm coupling; follow the diagrams on the hitch to ensure oil is applied correctly. This is shown in figure 7.

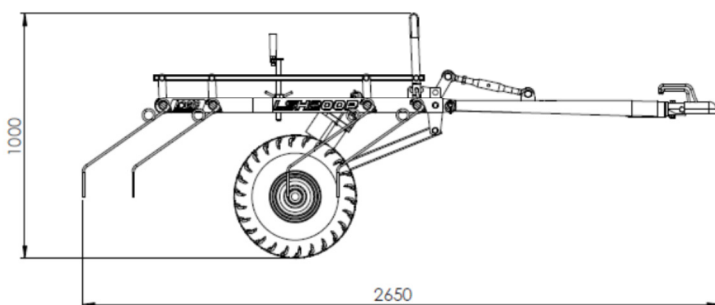
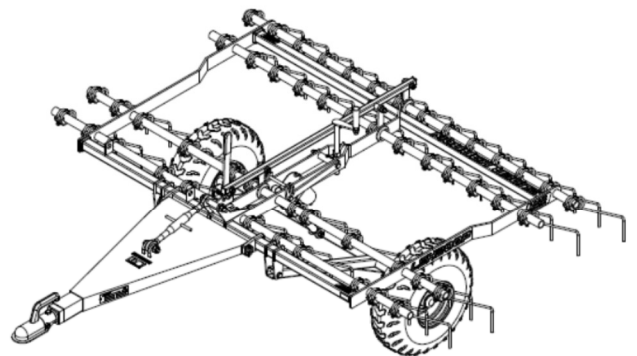
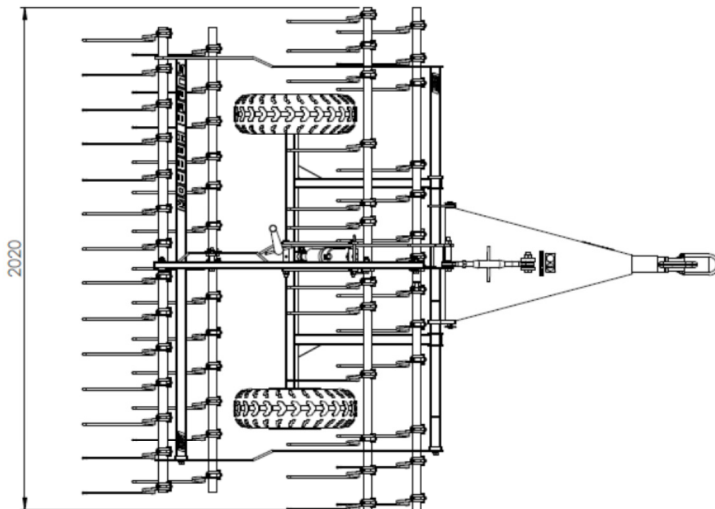

Figure 7

8

SPECIFICATIONS

	LSH200P
Max machine width	2020mm
Max machine Height	1000mm
Max machine length (Including drawbar)	2650mm
Max working width	2000mm
Weight	127kg
Hitch	50mm ball swivel coupling
Raise / Lower	Electric
Wheel / Tyres	WL/TY 20 x 7 - 8
Max speed	20mph
Spring tines	Einbock™
Diameter of tine	8mm
Tine spacing	50mm
Number of tines	52



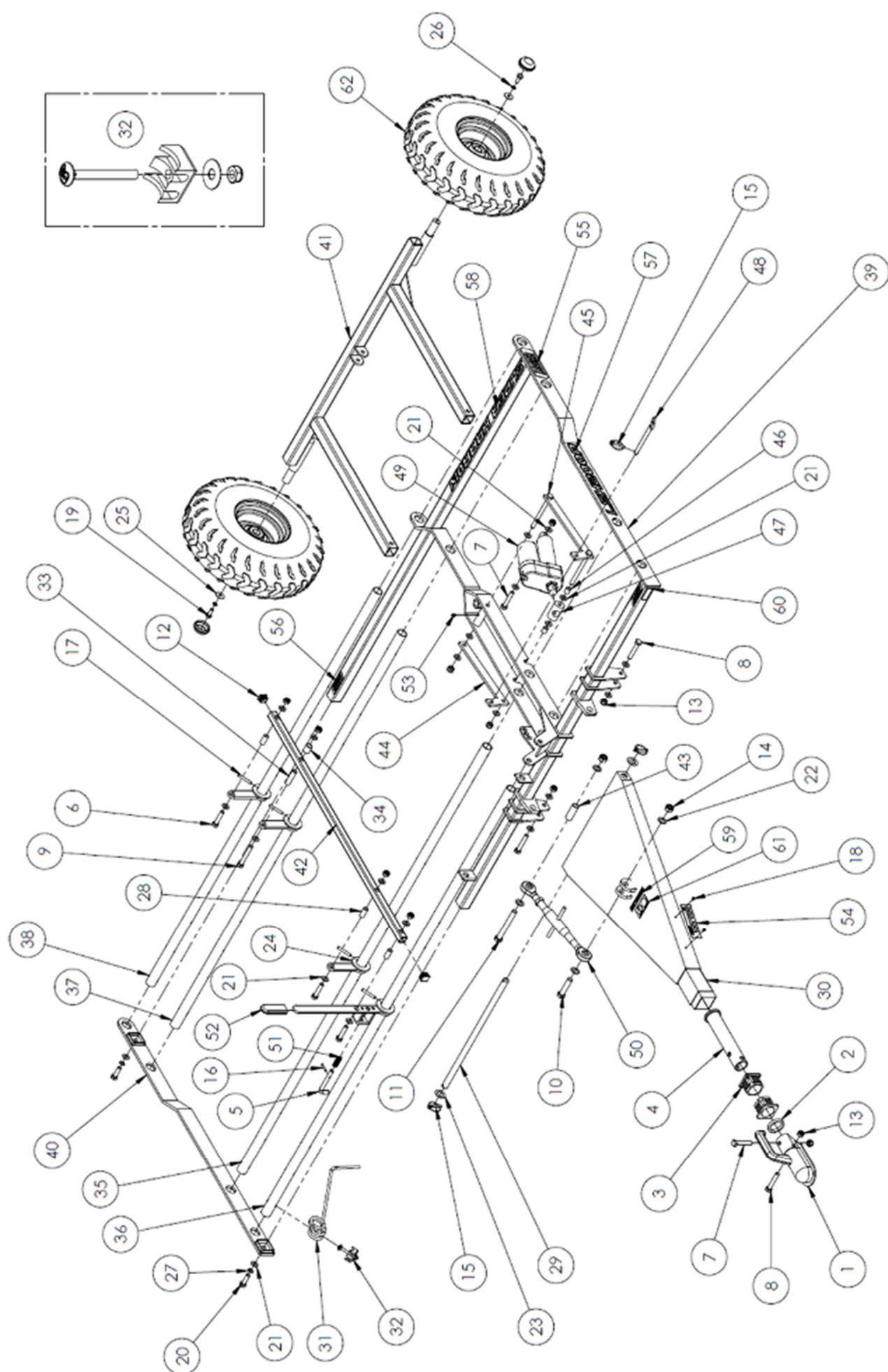

ITEM NO.	PART NUMBER	DESCRIPTION	QTY.
1	C900	COUPLING 50MM H/D WINTERHOFF	1
2	CM100-01A	THRUST WASHER	1
3	CM100-03A	SWIVEL NYLON BUSH	2
4	CM100-04	SWIVEL HITCH DRAW TUBE	1
5	CTF910-08	HEIGHT ADJUSTING PIN	1
6	FBH12055	BOLT M12 x 55 MM	3
7	FBH12065	BOLT M12 x 65 MM	2
8	FBH12070	BOLT M12 x 70 MM	3
9	FBH12085	BOLT M12 x 85 MM	1
10	FBH16065	BOLT M16 x 65 MM	1
11	FBH16130	BOLT M16 x 130 MM	1
12	FIP025025	INSERT PLASTIC 25 X 25 X 2-32 MM	2
13	FNN12	M12 NYLOC	11
14	FNN16	M16 NYLOC NUT	2
15	FPL06	PIN LINCH 6MM	3
16	FPS05030	PIN SPIROL M5 X 30 MM	1
17	FPS08050	PIN SPIROL M8 X 50 MM	4
18	FRP03010	RIVET POP 1/8 X 3/8	2
19	FSH10025	SET SCREW M10 X 25 MM	2
20	FSH12040	SET SCREW M12 X 40 MM	2
21	FWF12	M12 WASHER FLAT	22
22	FWF16	M16 WASHER FLAT	4
23	FWF20	M20 WASHER FLAT	2
24	FWF36066	FLAT WASHER M36 X 66 X 5MM	4
25	FWR10030	FLAT WASHER M10 X 30 REPAIR	2
26	FWS10	M10 WASHER SPRING	2
27	FWS12	M12 WASHER SPRING	2
28	LPH201-07	ADJUSTMENT LINK BAR BUSH	3
29	LPH201-20	DRAWBAR PIN	1
30	LPH201-25A	DRAWBAR ASSEMBLY	1
31	LPH201-43	TINE EINBOCK 8MM	1
32	LPH201-44	FIXING KIT TINE 8 MM	1
33	LPH201-45	ADJUSTMENT LINK BAR LONG BUSH	1
34	LPH201-46	MID TINE BAR ADJ BRKT SPACER	1
35	LSH201-01A	WHEEL TINE TUBE ASSEMBLY	1
36	LSH201-02A	FRONT TINE TUBE ASSEMBLY	1
37	LSH201-03A	MID TINE TUBE ASSEMBLY	1

ITEM NO.	PART NUMBER	DESCRIPTION	QTY.
38	LSH201-04A	REAR TINE TUBE ASSEMBLY	1
39	LSH201-05A	MAIN FRAME ASSEMBLY	1
40	LSH201-06A	END TINE BAR MOUNTING PLATE ASSEMBLY	1
41	LSH201-08A	AXLE ASSEMBLY	1
42	LSH201-09	ADJUSTMENT LINK BAR	1
43	LSH201-11	TURNBUCKLE MOUNTING SPACER	1
44	LSH201-13	FLOAT ARM	1
45	LSH201-13A	FLOAT ARM ASSEMBLY	1
46	LSH201-15	FLOAT SPACER	2
47	LSH201-16	ACTUATOR BUSH	1
48	LSH201-18A	FLOAT LOCK PIN	1
49	ME-A001	ACTUATOR STROKE 4"	1
50	MFG104-15	TURNBUCKLE	1
51	MSU-S007	SPRING FOR SPRING BOLT KIT 89	1
52	MSU-S100	SLEEVE FLAT GREY 31.75MM X 9.5	1
53	TA102-03	GREASE NIPPLE STRAIGHT 6 MM	1
54	WP05	MANUFACTURERS PLATE UNIVERSAL	1
55	WS02	STICKER: LOGIC - 153 X 47 MM	2
56	WS03	STICKER: LOGIC - 80 X 25 MM	2
57	WS211	STICKER: LSH200P	2
58	WS212	STICKER: SUPER HARROW	1
59	WS36	STICKER: DESIGN RIGHT	1
60	WS64	STICKER: SER.NO.N/PLATE 50.4x19.1	1
61	WS68	STICKER: READ OPERATORS MANUAL	1
62	WT210	WHEEL & TYRE 20X7-8 CSLE TRAILWOLF	2

This Logic Manufacturing Ltd. product is guaranteed against faulty workmanship and materials for a period of 12 months from the date of purchase.

On Engine-Powered equipment, the engine manufactures guarantee will apply, any claims being subject to their terms and conditions.

All claims must be made in writing within 28 days of the alleged failure.

All claims must be made through the dealer who originally supplied the machine.

Any defective parts must be kept for inspection and if requested, sent to the factory or dealer.

The customer must bring equipment for repair to the dealer.

This guarantee becomes void if unauthorised modifications have been made, or if parts not manufactured, supplied or approved by Logic Manufacturing Ltd. have been fitted to the machine.

We accept no liability for normal wear and tear, misuse or abuse, or where recommended maintenance has not been carried out.

All guarantee work must be authorised by Logic Manufacturing Ltd. prior to any work being done. Work carried out without our consent may not be reimbursed.



DECLARATION OF CONFORMITY
93 / 44 EEC



LOGIC MANUFACTURING LTD

Foundry Industrial Estate
Bridge End
HEXHAM
Northumberland

Product Type: **LSH200P**

Covered By Technical File Number: **CE – LSH200**

Serial Number:

Standards and Regulations Used:

The Supply of Machinery (Safety) Regulations 1992
HSE Guidelines on ATV Equipment (Agric Sheet No. 33)

Place of Issue: **United Kingdom**

Name of Authorised Representative: **S A WEIR**

Position of Authorised Representative: **PRODUCT DEVELOPMENT MANAGER**

Declaration,

I declare that as the authorised representative, the above information in relation to the supply / manufacture of this product, is in conformity with the stated standards and other related documents following the provisions of 93/68EEC directives

Signature of Authorised Representative

Date: **27/02/2017**