

5.5 PARKING BRAKE DISASSEMBLY AND ASSEMBLY (PARKING BRAKE PAD REPLACEMENT)

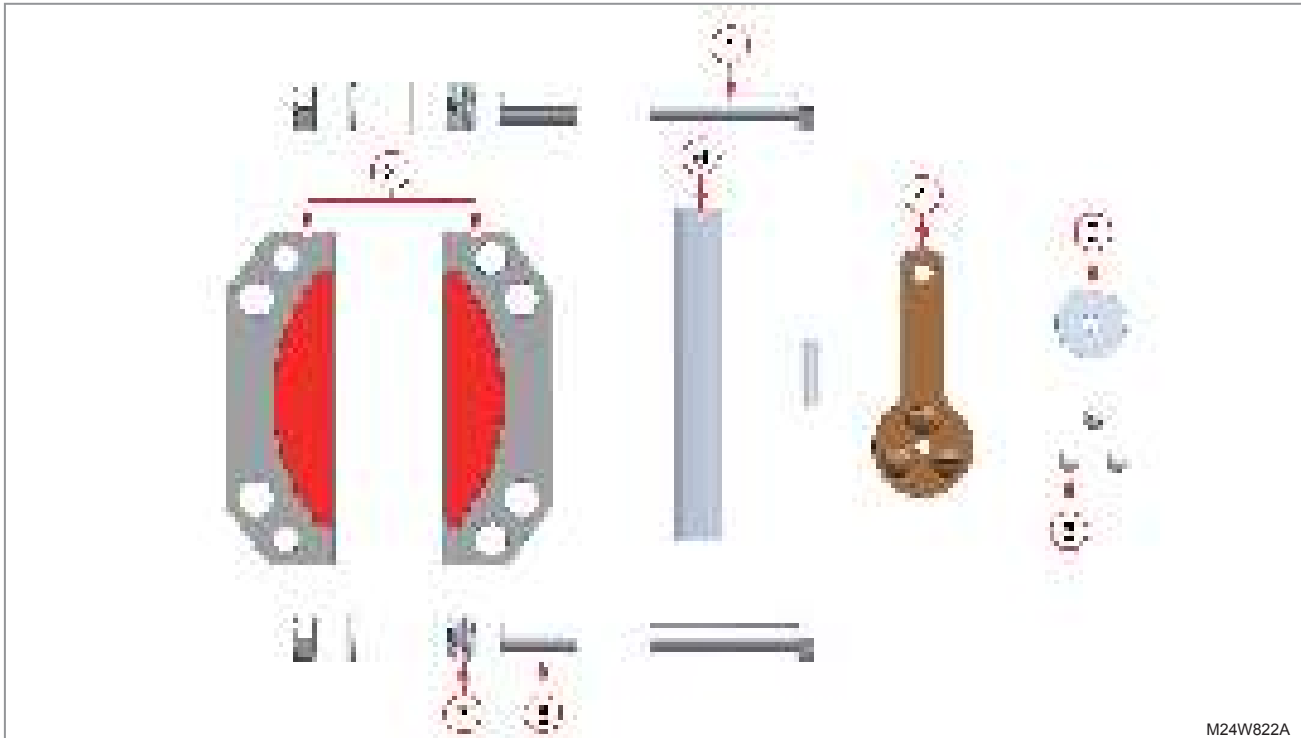

1. Unscrew the parking brake caliper mounting bolts (1) (M10, 2 EA) to remove the pad (2), support plate (3), cam lever (4), ball (5), bracket (6), spring (7) and spacer (8) in order.

2. Assemble in the reverse order of disassembly.

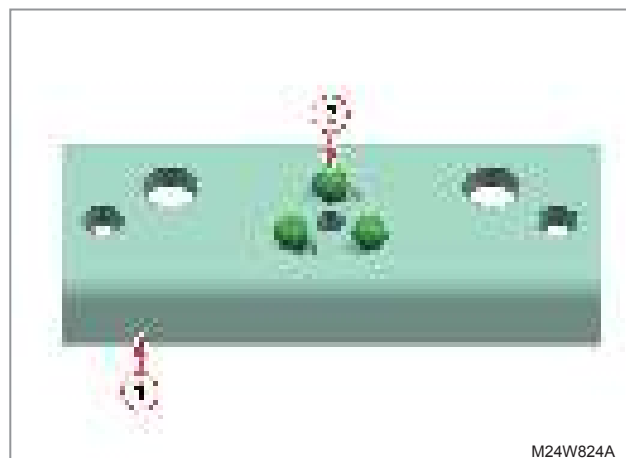

- Apply a small amount of grease to the bracket (1) and place the balls (2) onto the bracket.

SAFETY FIRST
GENERAL
ENGINE
CVT
TRANSMISSION
CHASSIS
REAR AXLE
BRAKE
FRONT AXLE
STEERING
HYDRAULIC
ELECTRIC
INDEX

SAFETY FIRST

GENERAL

ENGINE

CVT

TRANSMISSION

CHASSIS

REAR AXLE

BRAKE

FRONT AXLE

STEERING

HYDRAULIC

ELECTRIC

INDEX

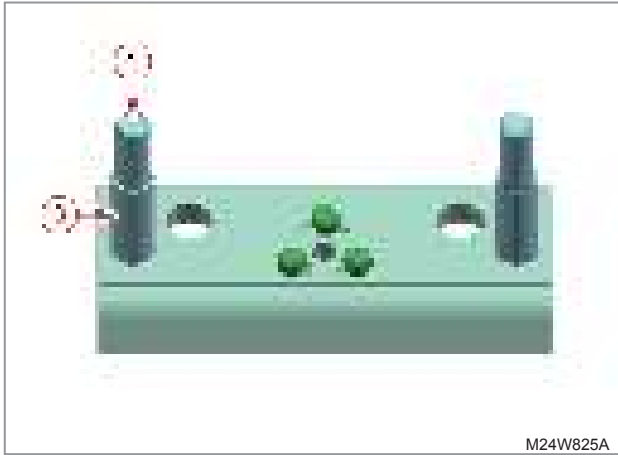

M24W825A

- Fit the bolts (1) to the bracket and insert the spacers (2).

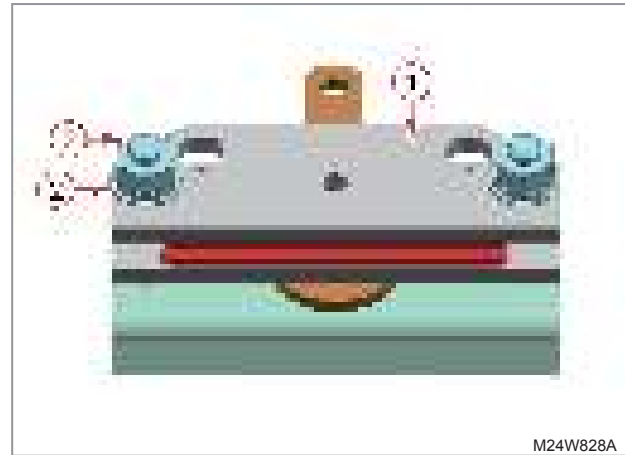

M24W828A

- Fit the other pad (1) to the bolts and tighten the spring washers (2) and nuts (3).

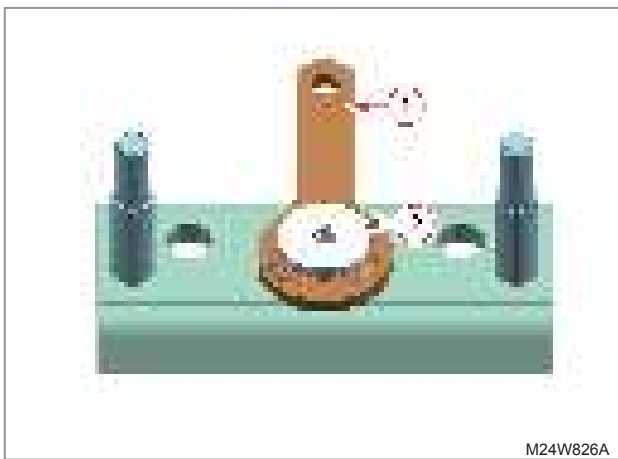

M24W826A

- Place the cam lever (1) onto the ball and fit the support plate (2).

! IMPORTANT

UUVW705A

- The clearance of the brake pad should be over 4.8 mm (0.189 in.).

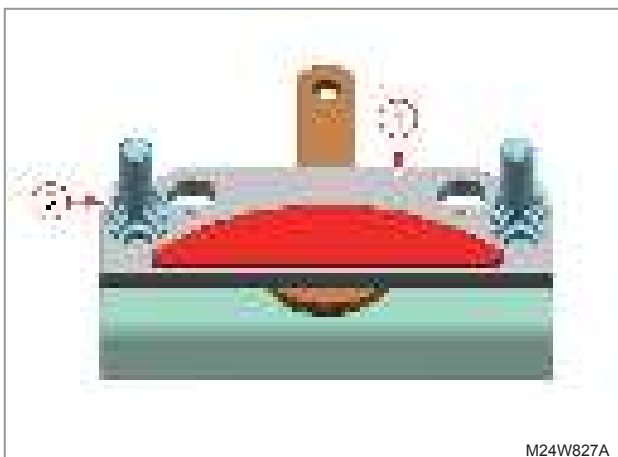

M24W827A

- Fit the pad (1) to the bolts and insert the springs (2).

6. COMPONENTS AND JOB CODES

6.1 G340002 REAR BRAKE GROUP (CREW)

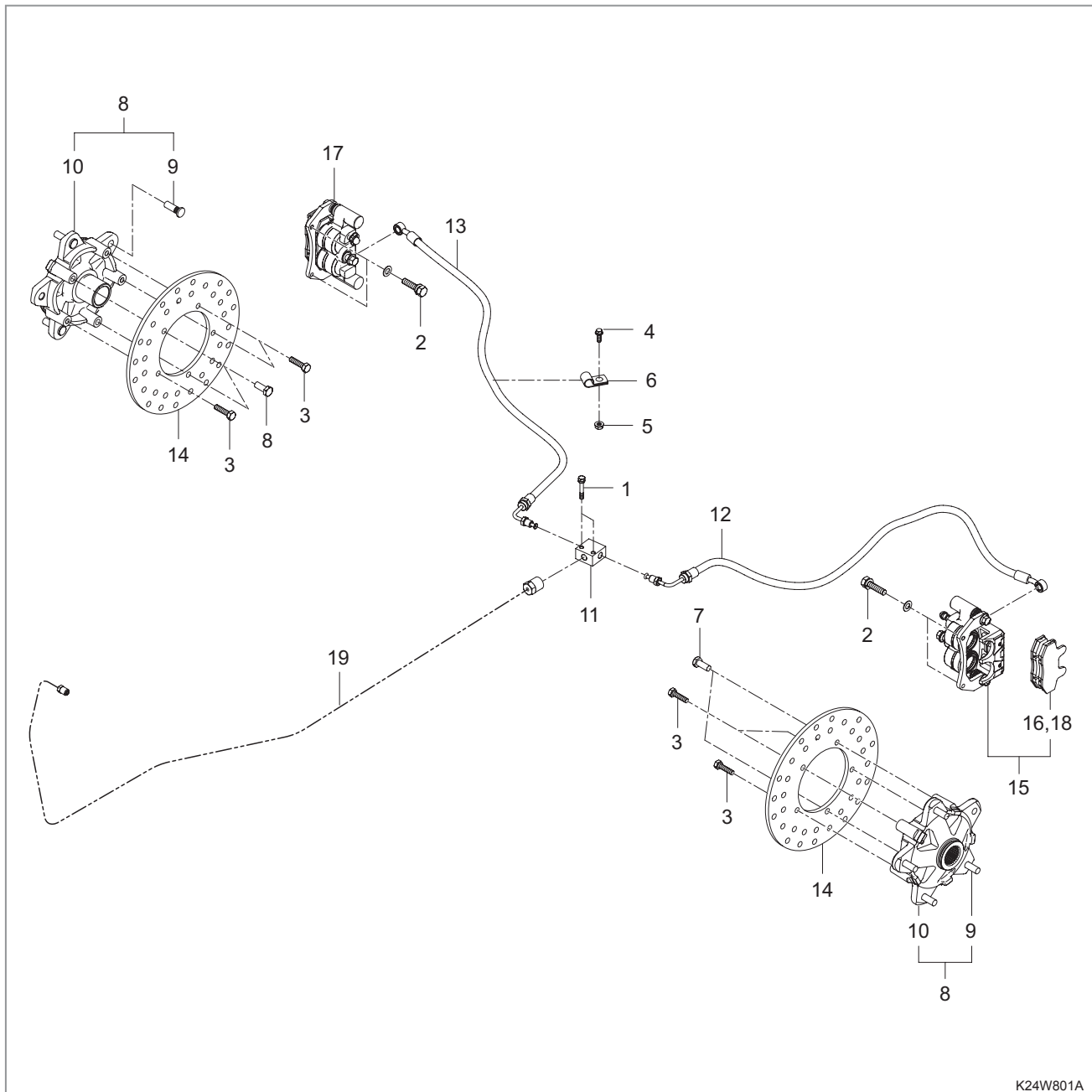

K24W801A

COMPONENTS AND JOB CODES

- | | |
|---|--|
| (1) Bolt, Washer | (11) Fitting Tee (W100003) |
| (2) Bolt, Washer | (12) Tube, Rr Brake,LH (W100004) |
| (3) Bolt | (13) Tube-RR Brake, RH (W100005) |
| (4) Bolt, Flange | (14) Brake Disc (W100006) |
| (5) Flange Nut | (15) Brake Calliper Assy, LH (W100007) |
| (6) Clamp | (16) Brake Pad Assy (W100008) |
| (7) Reamer Bolt, Hub & Disc MTG.(M8x1.25) | (17) Brake Calliper Assy, RH (W100009) |
| (8) Hub Assy-RR (W100001) | (18) Brake Pad Assy |
| (9) Bolt-hub(M10x1.25) | (19) Pipe_RR Brake |
| (10) Hub-RR (W100002) | |

SAFETY FIRST
GENERAL
ENGINE
CVT
TRANSMISSION
CHASSIS
REAR AXLE
BRAKE
FRONT AXLE
STEERING
HYDRAULIC
ELECTRIC
INDEX

SAFETY FIRST

GENERAL

ENGINE

CVT

TRANSMISSION

CHASSIS

REAR AXLE

BRAKE

FRONT AXLE

STEERING

HYDRAULIC

ELECTRIC

INDEX

6.2 G320001 FRONT BRAKE GROUP

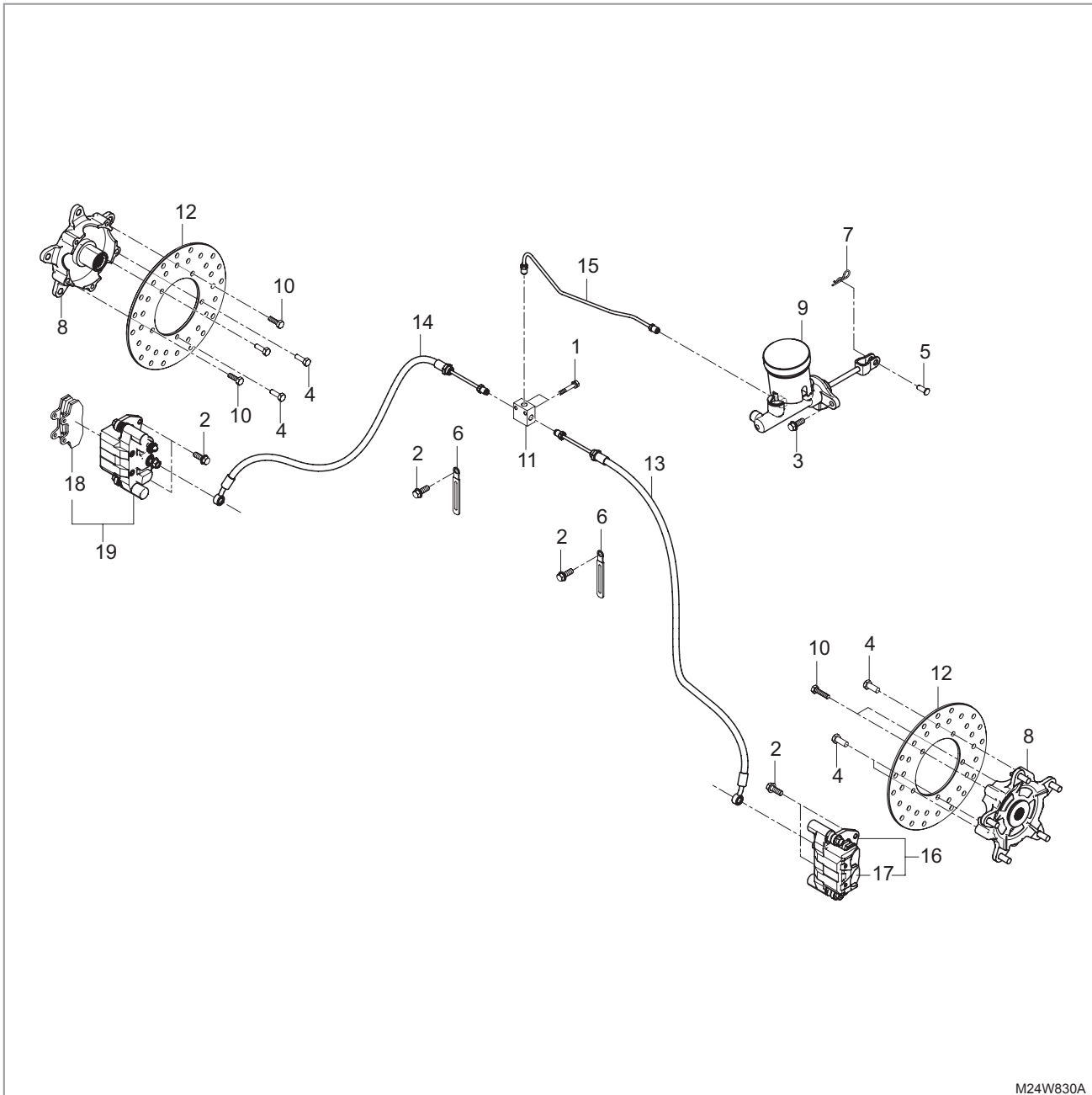

M24W830A

COMPONENTS AND JOB CODES

- | | |
|---|--|
| (1) Bolt | (11) Fitting Tee (W090003) |
| (2) Bolt, Washer | (12) Brake Disc (W090004) |
| (3) Bolt, Washer | (13) Front Brake Tube, LH (W090005) |
| (4) Bolt | (14) Front Brake Tube, RH (W090006) |
| (5) Joint Pin | (15) Front Brake Pipe (W090007) |
| (6) Wirg Clamp | (16) Brake Calliper Assy, LH (W090008) |
| (7) Cir Clip | (17) Brake Pad Assy (W090009) |
| (8) Hub Assy, FR (W090001) | (18) Brake Pad Assy (W090009) |
| (9) Master Cylinder Assy (W090002) | (19) Brake Calliper Assy, RH (W090010) |
| (10) Reamer Bolt, Hub & Disc MTG. (M8x1.25) | |

6.3 G310001 BRAKE PEDAL GROUP

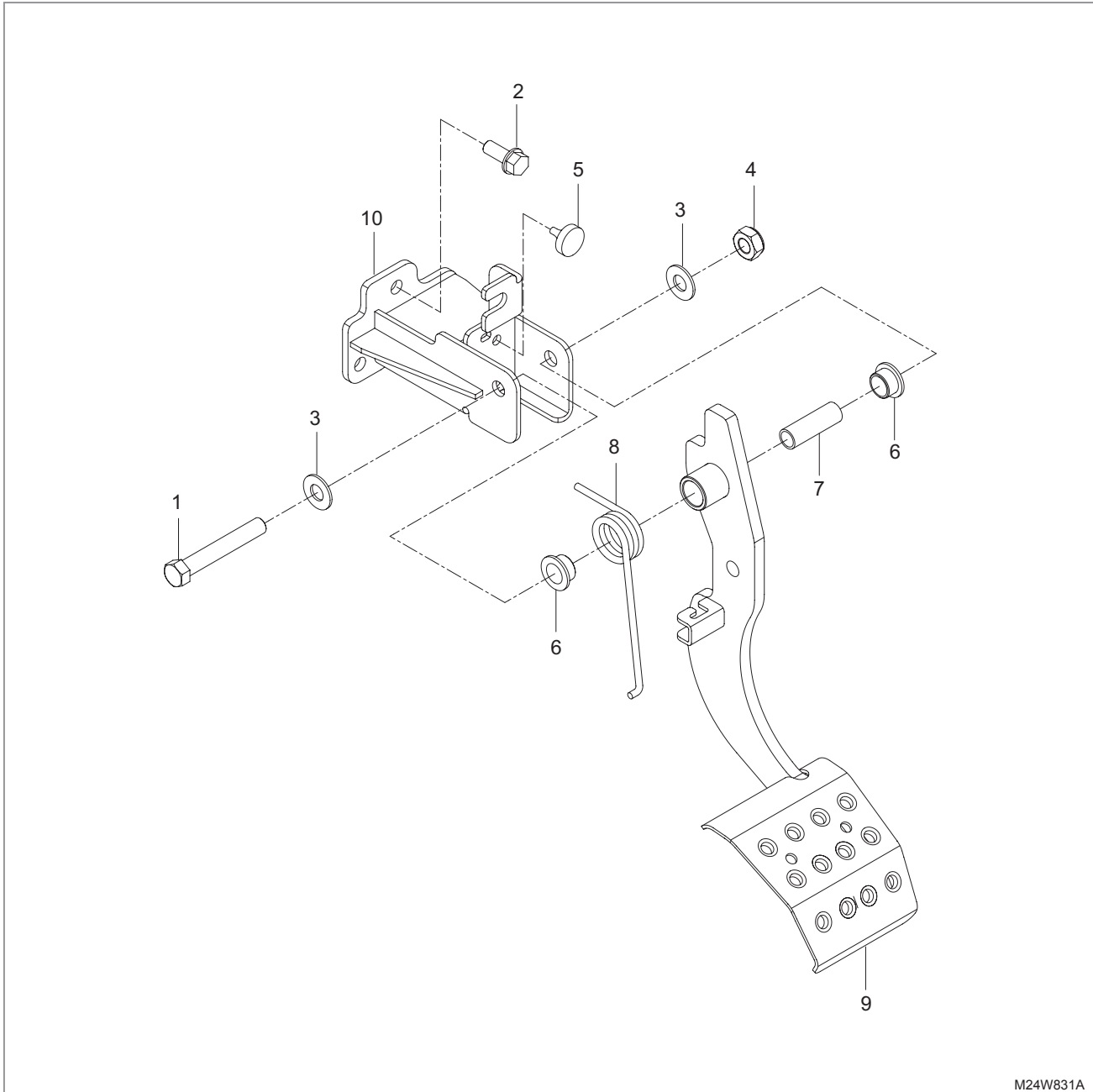

M24W831A

COMPONENTS AND JOB CODES

- | | |
|---------------------|---------------------------------------|
| (1) Bolt | (6) Bush, Brake Pedal Pivot (W080001) |
| (2) Flange Bolt | (7) Brake Hinge Spacer (W080002) |
| (3) Plain_washer | (8) Break Spring (W080003) |
| (4) U-nut | (9) Brake Pedal Assy (W080004) |
| (5) Rubber, Cushion | (10) Brake Hinge Assy (W080005) |

SAFETY FIRST
GENERAL
ENGINE
CVT
TRANSMISSION
CHASSIS
REAR AXLE
BRAKE
FRONT AXLE
STEERING
HYDRAULIC
ELECTRIC
INDEX

- SAFETY FIRST
- GENERAL
- ENGINE
- CVT
- TRANSMISSION
- CHASSIS
- REAR AXLE
- BRAKE**
- FRONT AXLE
- STEERING
- HYDRAULIC
- ELECTRIC
- INDEX

6.4 G360005 PARKING BRAKE GROUP (US, CREW)

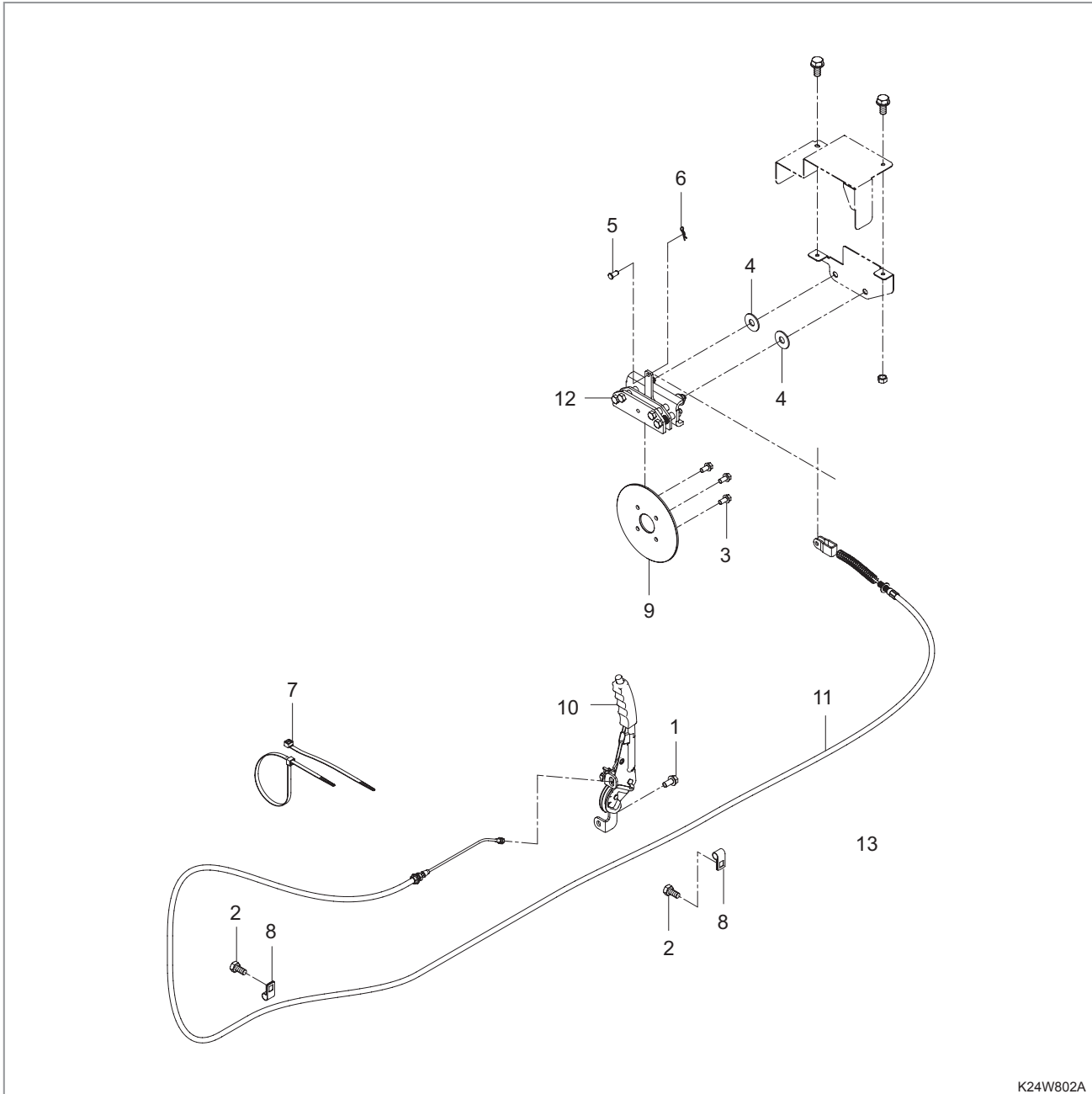

K24W802A

COMPONENTS AND JOB CODES

- | | |
|-------------------|---|
| (1) Bolt | (8) Clip |
| (2) Bolt, Flange | (9) Disk, Parking Brake (W110001) |
| (3) Bolt, Flange | (10) Parking Brake Lever Assy (W110002) |
| (4) Washer, Plain | (11) Parking Brake Cable Assy (W110003) |
| (5) Joint Pin | (12) Caliper Assy, Park Brake(US) (W110004) |
| (6) Pin, Snap | (13) Pad, Parking Brake (W110005) |
| (7) Band, Cord | |



**K9 2400
K9 2440**

FRONT AXLE

CHAPTER 9

TABLE OF CONTENTS

1. SPECIFICATIONS	9-2	5. DISASSEMBLY, SERVICE AND ASSEMBLY	9-13
1.1 General specifications	9-2	5.1 CV joint removal	9-13
1.2 Tightening torque	9-3	5.2 CV joint boot replacement	9-15
1.3 Sealant and adhesive	9-3	5.3 Front axle case removal	9-17
2. STRUCTURE AND FUNCTION	9-4	5.4 Front axle case disassembly and assembly.....	9-18
2.1 Front axle power transfer diagram.....	9-4	5.5 Differential system disassembly and assembly.....	9-19
2.2 LSD (Limited Slip Device).....	9-6	5.5.1 Differential system disassembly....	9-19
3. TROUBLESHOOTING	9-7	5.5.2 Differential system assembly ...	9-20
4. INSPECTION AND ADJUSTMENT	9-8	5.6 LSD disassembly and assembly	9-21
4.1 Toe-in adjustment	9-8	5.7 Front axle knuckle assembly disassembly and assembly.....	9-22
4.2 Turning torque of 8 bevel pinion shaft ...	9-8	5.8 Propeller shaft (front universal joint) replacement	9-24
4.3 Backlash of differential pinion and differential side gear	9-9	6. COMPONENTS	9-25
4.4 Backlash of 8 bevel pinion shaft and 34 bevel gear	9-10	6.1 G250001 Front suspension group (CVT) ..	9-25
4.5 Tooth contact of spiral bevel gear	9-11	6.2 G130001 Front axle case group	9-26
4.6 Differential system clearance check.....	9-12	6.3 G132001 Bevel pinion shaft group	9-27
4.6.1 Differential pinion and differential pinion shaft	9-12	6.4 G160001 4WD CV joint group	9-28
4.6.2 Differential case, spiral bevel gear and differential side gear ...	9-13	6.5 G131001 Front diff system group	9-29



FRONT AXLE - SPECIFICATIONS

K9 2400
K9 2440

SAFETY FIRST

1. SPECIFICATIONS

1.1 GENERAL SPECIFICATIONS

GENERAL

ENGINE

CVT

TRANSMISSION

CHASSIS

REAR AXLE

BRAKE

FRONT AXLE

STEERING

HYDRAULIC

ELECTRIC

INDEX

Item	Specifications		Remarks
Oil	SAE gear oil #90 or DAEDONG UTF55		
	Exxon	Mobil fluid 423/424	
	BP	Tractran UTH	
	Shell	DONAX-TD	
Grease	NLGL grade No.2 or equivalent		Lower section of hub strut
Front axle case oil capacity	0.6 ℓ (0.16 u.s.gal)		
Turning radius	K9 2400	4.3 m (14.1 ft)	
	K9 2440	5.4 m (17.7 ft)	
Front tire	Size 25 x 10 - 12 6PR Inflation pressure: 1.69 kgf/cm ² (165.4 kPa, 24 psi)		
Front wheel	Tread: 1,262 mm (49.7 in.)		
Suspension	Independent MacPherson strut suspension		

1.2 TIGHTENING TORQUE

Position	Size	Tightening torque
Front wheel mounting nut	M10	39.2 ~ 45.1 Nm 4.0 ~ 4.6 kgf-m 28.8 ~ 33.1 lb-ft
Slotted tie rod end nut	M10	54.0 ~ 61.0 Nm 5.4 ~ 6.1 kgf-m 38.9 ~ 43.9 lb-ft
Front axle suspension (upper/lower strut sections))	M12	63.7 Nm 6.5 kgf-m 46.8 lb-ft
Knuckle support arm mounting section (upper)	M14	101 Nm 10.31 kgf-m 74.20 lb-ft
Knuckle support arm mounting carrier section	M10	41.0 Nm 4.18 kgf-m 30.12 lb-ft
Differential case & spiral bevel gear mounting bolt	M8	29.4 ~ 34.3 Nm 3.0 ~ 3.5 kgf-m 21.6 ~ 25.2 lb-ft
Front axle case mounting bolt	M10	48.0 ~ 55.9 Nm 4.9 ~ 5.7 kgf-m 35.3 ~ 41.0 lb-ft

1.3 SEALANT AND ADHESIVE

Spiral bevel gear mounting bolt	LOCTITE 271 (RED) or equivalent
Mating surface of front axle case and cover	DOW CORNING ®737 or equivalent

SAFETY FIRST

GENERAL

ENGINE

CVT

TRANSMISSION

CHASSIS

REAR AXLE

BRAKE

FRONT AXLE

STEERING

HYDRAULIC

ELECTRIC

INDEX

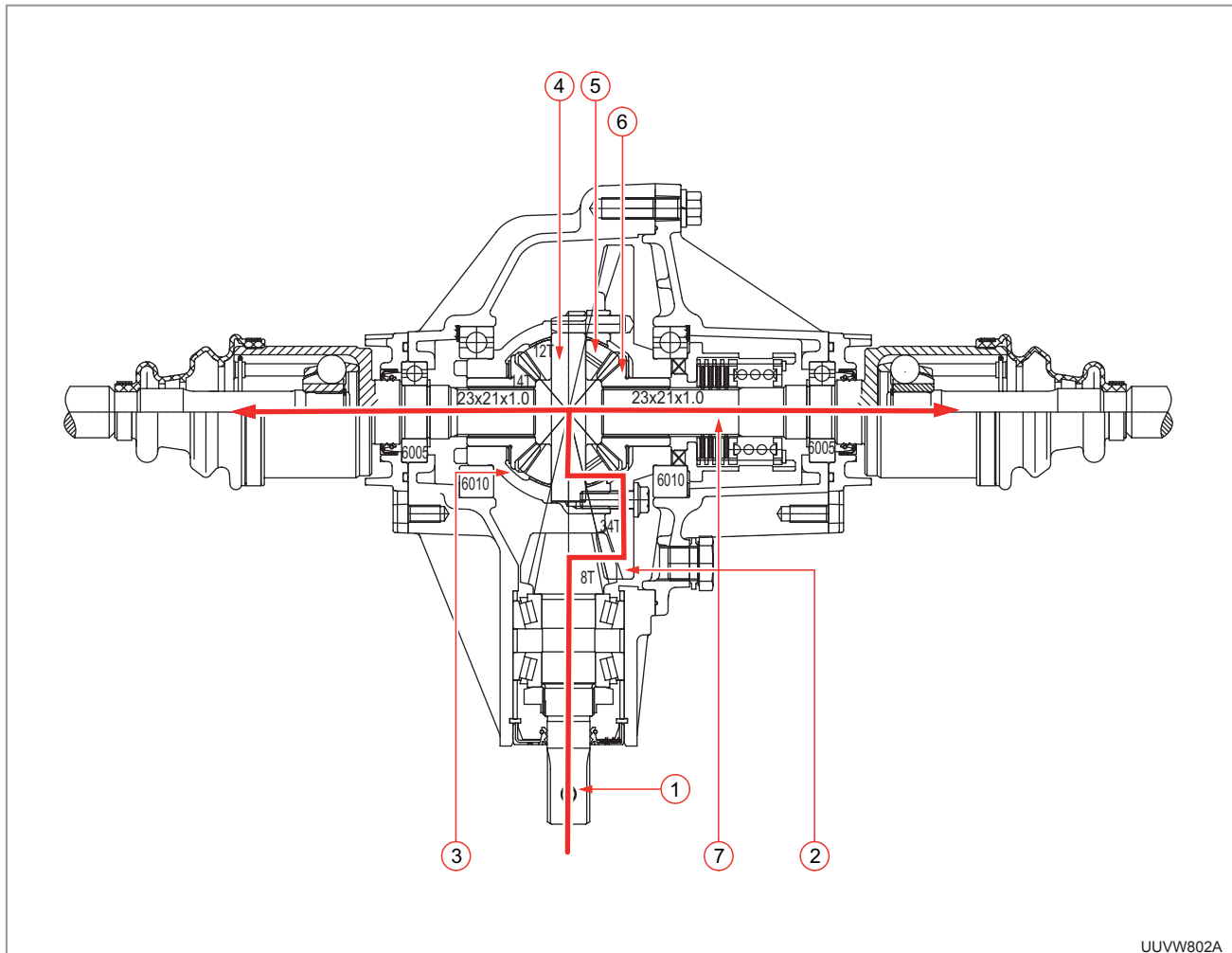

- As the power is transferred from the transmission through the front propeller shaft, it is passed to the differential case through the 8 bevel pinion shaft and 34 bevel gear. Then, the internal bevel gear is rotated by the rotating differential case and the power is transferred to the front wheel drive shaft, which is connected to the differential side gear, in order to drive the front wheels.
- Power transfer
 - 1) 8 bevel pinion shaft → 2) 34 spiral bevel gear → 3) Front differential case → 4) Differential pinion shaft →
 - 5) Differential pinion → 6) Differential side gear → 7) CV joint

SAFETY FIRST
GENERAL
ENGINE
CVT
TRANSMISSION
CHASSIS
REAR AXLE
BRAKE
FRONT AXLE
STEERING
HYDRAULIC
ELECTRIC
INDEX

2.2 LSD (LIMITED SLIP DEVICE)

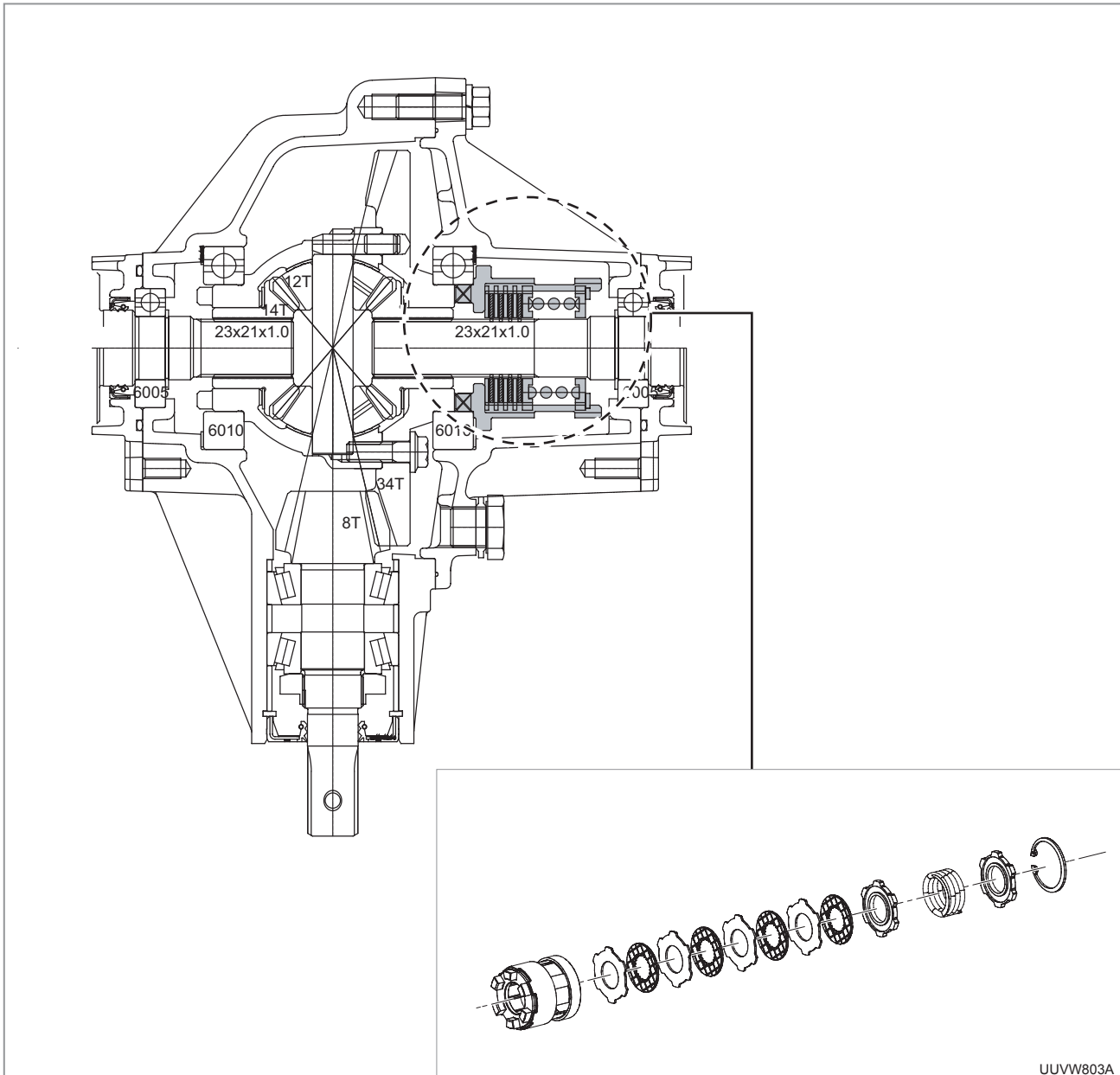

The rear axle is equipped with the manual differential lock as a dog clutch while the front axle is equipped with the automatic LSD (Limited Slip Differential).

The LSD consists of four friction discs, four plates and one pressure spring. Some differential lock effect can be achieved only by fixing the spiral bevel gear (ring gear) and one axle to each other. When the vehicle is driven or cornering on a normal paved road, the turning speed difference between the ring gear and axle is not immense and the friction between the friction disc and plate can be tolerant. However, when excessive turning speed difference between the left and right of the axle is occurred by imbalanced friction applied to the right and left wheels on a slippery road, the turning speed difference between the friction disc and plate becomes excessive, resulting in immense friction. As a result, this friction reduces some level of a speed difference by the differential to help the vehicle escape from a slippery area easily.

The half of this friction clutch pack is always soaked in lubricant to achieve durability of the friction disc.

3. TROUBLESHOOTING

Symptom	Cause	Solution
Front wheels wander to right or left	<ul style="list-style-type: none"> • Uneven tire pressure • Improperly adjusted toe-in (improper wheel alignment) • Loose tie rod end 	<ul style="list-style-type: none"> • Adjust • Adjust • Tighten
Front wheel cannot be driven	<ul style="list-style-type: none"> • Broken drive shaft • Broken front wheel drive gear in transmission • Broken front differential gear • Loose front wheel drive cable 	<ul style="list-style-type: none"> • Replace • Replace • Replace • Adjust or replace
Abnormal noise from front axle	<ul style="list-style-type: none"> • Insufficient oil • Damaged gears • Damaged bearings • Abnormal backlash • Improperly adjusted pre-load on taper roller bearing of spiral pinion shaft • Bad CV joint 	<ul style="list-style-type: none"> • Change and replenish oil • Replace the damaged part • Replace the damaged part • Adjust the backlash • Adjust the pre-load • Replace CV joint
Oil leaked from front differential case	<ul style="list-style-type: none"> • Excessive oil • Damaged O-rings • Clogged overflow pipe • Damaged seal of spiral pinion shaft • Damaged taper roller bearing of spiral bevel pinion shaft 	<ul style="list-style-type: none"> • Add proper amount of oil • Replace the O-ring • Clean. Replace if necessary • Replace • Replace, adjust the pre-load
Broken front axle drive shaft	<ul style="list-style-type: none"> • Improper front tire installed • Deformed front/rear tires • Abnormal front/rear wheel drive ratio • Improper tire inflation pressure 	<ul style="list-style-type: none"> • Check the specified tire speed (refer to "GENERAL") • Check the specified tire speed (refer to "GENERAL") • Use the specified tire only. • Keep the specified tire inflation pressure
Improper steering	<ul style="list-style-type: none"> • Abnormal toe-in (vehicle cannot move straight forward) • Damaged tie rod • Different inflation pressure between left and right tires 	<ul style="list-style-type: none"> • Adjust • Replace • Replace the tires

SAFETY FIRST
GENERAL
ENGINE
CVT
TRANSMISSION
CHASSIS
REAR AXLE
BRAKE
FRONT AXLE
STEERING
HYDRAULIC
ELECTRIC
INDEX

4. INSPECTION AND ADJUSTMENT

4.1 TOE-IN ADJUSTMENT

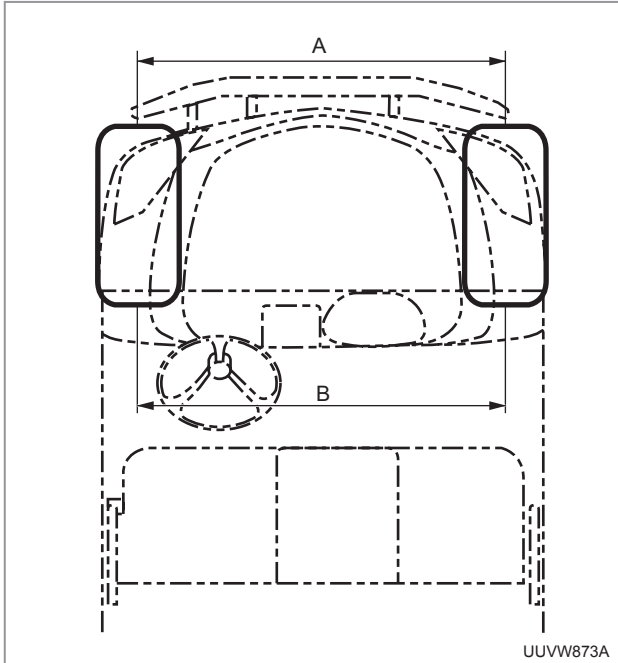

1. Park the vehicle on level ground, stop the engine and apply the parking brake.
2. Lift the front axle slightly with a hydraulic jack and set the front wheels in a straight ahead position.
3. Measure the distance between the front and rear part of the front wheels (on hub level).
4. Adjust the toe-in so that the rear distance (B) is 2 to 8 mm longer than the front distance (A).
[B - A = 2 ~ 8 mm (0.0787 ~ 0.3149 in.)]



5. To adjust the toe-in, unscrew the mounting nuts (1) at the ends of the tie rod, turn the tie rod end to set the toe-in to the specification and tighten the mounting nuts again.

4.2 TURNING TORQUE OF 8 BEVEL PINION SHAFT



1. After tying the pinion shaft with a string, measure the load by pulling the string down with a pull scale.

Load of pull scale.... 9.2 ~ 12.2 kgf
20.3 ~ 26.9 lbs

When measuring the load by engaging a torque wrench to the spline of the spiral bevel pinion shaft:

Torque value 0.88 ~ 1.176 Nm
0.09 ~ 0.12 kgf-m
0.65 ~ 0.87 lbf-ft

When measuring the load by a pull scale as shown in the figure:

$$\text{Load of pull scale (F) (kgf)} = \frac{\text{Torque value (T) (kgf-m)}}{\text{Radius of spline shaft (R)}}$$

$$F = \frac{0.09 \sim 0.12 \text{ kgf-m}}{R (0.0098 \text{ m})}$$

$$F = 9.2 \sim 12.2 \text{ kgf} (20.3 \sim 26.9 \text{ lbs})$$

REMARK

- The pre-load of the taper roller bearing, that supports the spiral bevel pinion shaft, can be adjusted by tightening its mounting nut. (Refer to the diagram in this chapter.) The standard pre-load is defined by the turning torque of the spiral bevel pinion shaft.
- The turning torque can be measured using a torque wrench or by tying the shaft with a string and pulling the string down with a pull scale. Make sure to convert the unit correctly.
- The turning torque and turning force can differ by the installation condition as shown in the following table:

		(A)	(B)	(C)	
Item	Installation condition	Nut tightened with spiral bevel pinion	(A)+ oil seal installed	(B)+differential case assembly & ring gear installed	
	Front axle	Torque	0.04 kgf-m	0.06	0.12
		Turning force	4.0 kgf	6.0	12.0

4.3 BACKLASH OF DIFFERENTIAL PINION AND DIFFERENTIAL SIDE GEAR



UUVW805A

1. Install the dial indicator (lever type) so that its pointer contacts with the surface of the differential side gear through the hole of the differential case as shown in the figure.
2. Measure the backlash of the differential side gear while moving the differential pinion gently.

**Standard backlash: 0.15 ~ 0.25 mm
(0.0059 ~ 0.0098 in.)**

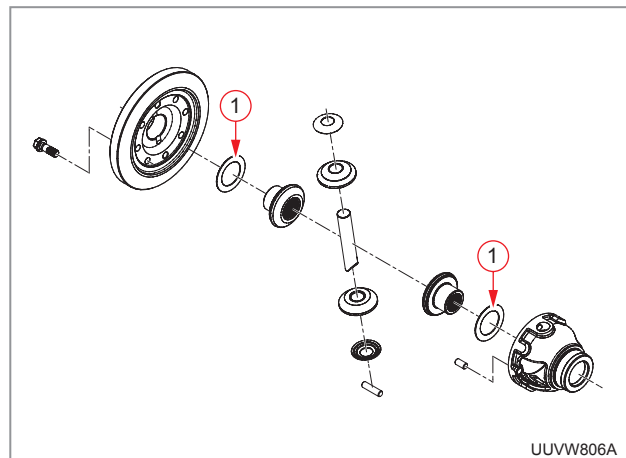

UUVW806A

3. If necessary, replace the shim (1) installed on the back of the differential side gear to adjust the backlash. However, the shims with the same thickness should be installed in both side gears.

Size of adjusting

- shim: 0.8 mm (0.031 in.)
- 1.0 mm (0.039 in.) Standard shim
- 1.2 mm (0.047 in.)

SAFETY FIRST

GENERAL

ENGINE

CVT

TRANSMISSION

CHASSIS

REAR AXLE

BRAKE

FRONT AXLE

STEERING

HYDRAULIC

ELECTRIC

INDEX

4.4 BACKLASH OF 8 BEVEL PINION SHAFT AND 34 BEVEL GEAR



1. Set the lever type dial indicator so that it contacts with the spline of the 8 spiral bevel pinion shaft as shown in the figure.
2. Measure the backlash by moving the 8 bevel pinion shaft by hand lightly.

Teeth based Backlash : 0.2 ~ 0.3 mm
(0.008 ~ 0.012 in.)

Spline based Backlash : 0.08 ~ 0.12 mm
(0.0031 ~ 0.0047 in.)

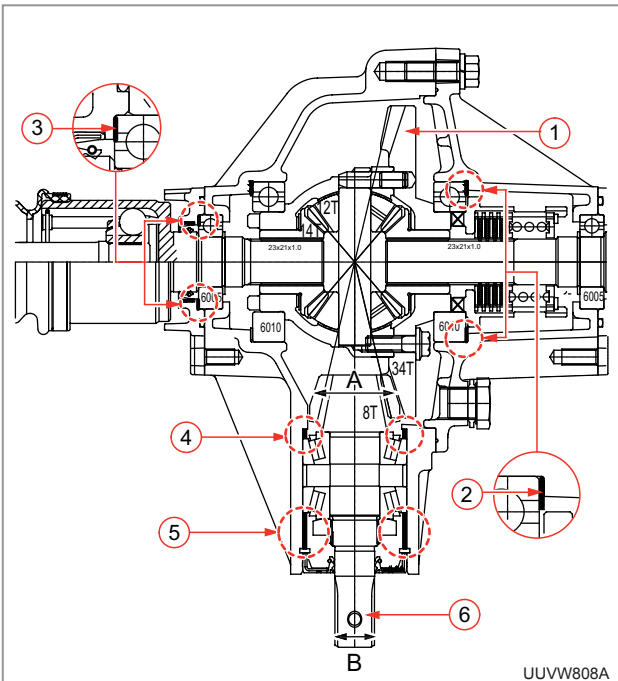

3. Adjust the shims (2) and (3) if the 34 spiral bevel gear (1) should be moved to adjust the backlash.

Size of shim : 0.1 mm (0.0039 in.)
0.2 mm (0.0079 in.)
0.4 mm (0.0157 in.)
0.8 mm (0.0315 in.)
1.0 mm (0.0394 in.)
1.2 mm (0.0472 in.)

4. Replace the collars (4) and (5) installed to the front and rear sides of the shaft if the 8 spiral bevel pinion shaft (6) should be moved. However, the total thickness of the front and rear collars should be 22.75 mm (0.8957 in.).

Size of adjusting collar : 4.55 mm (0.1791 in.)
4.65 mm (0.1831 in.)
4.75 mm (0.1870 in.)
4.85 mm (0.1909 in.)
4.95 mm (0.1949 in.)
17.8 mm (0.7008 in.)
17.9 mm (0.7047 in.)
18.0 mm (0.7087 in.)
18.1 mm (0.7126 in.)
18.2 mm (0.7165 in.)

5. Measure the contact area if the shim or collar has been adjusted.

This procedure can be skipped if it is not necessary to adjust the shim.

REMARK

- The standard backlash stated in the previous page refers to the distance from the mating surface of the gear teeth. Therefore, the standard backlash value can differ if the backlash is measured at the splined section of the pinion shaft.
- As the average effective diameter A of the spiral bevel pinion teeth is different from the effective diameter B of the splined section as shown in the figure on the previous page, the backlash on the spline can be obtained from the following formula:

Backlash measured at splined section

$$= \text{Teeth based backlash} \times \frac{B}{A}$$

$$\frac{B}{A} \approx 0.4$$

Therefore the spline based backlash is
0.2 x 0.4 ~ 0.3 x 0.4 = 0.08 ~ 0.12 mm
(0.0031 ~ 0.0047 in.)

4.5 TOOTH CONTACT OF SPIRAL BEVEL GEAR

INSPECTION

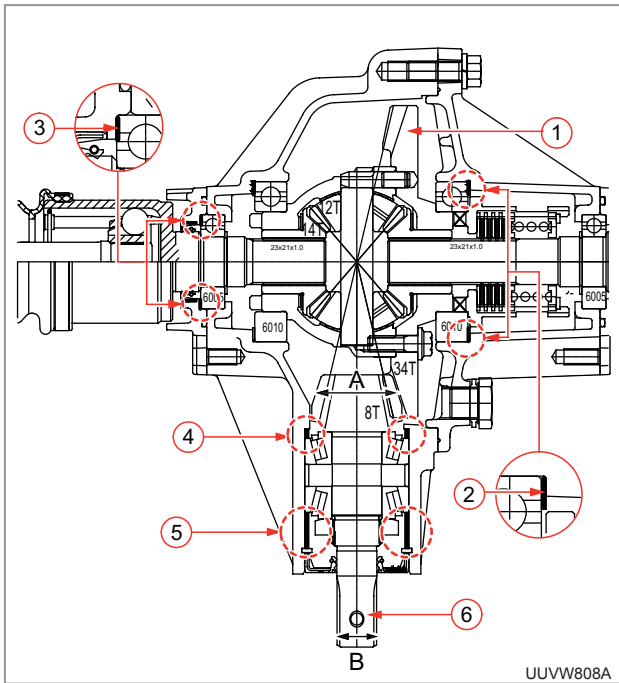

1. Remove the 8 bevel pinion shaft (6) and 34 spiral bevel gear (1) and clean the teeth thoroughly.
2. Coat all the teeth of the pinion shaft (3) with contact grease and reassemble it.
3. Turn the pinion shaft for approx. 10 rounds and check the contact area by a contact mark on the teeth of the 34 spiral bevel gear (1).
4. Adjust the teeth contact with the shim (2), (3), (4) and (5).

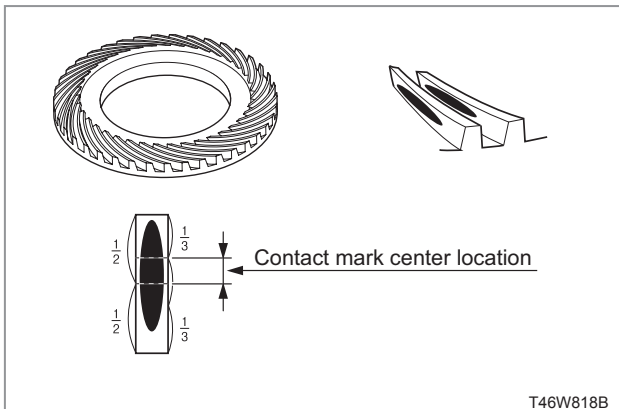

The contact area should be over 35 % of the entire teeth area and the center of the contact mark should be close to the center of the pinion in height. Also, the center of the contact mark should be located on the 1/3 spot from the toe of the teeth to the center of the teeth in length.

ADJUSTMENT

A. TOE CONTACT

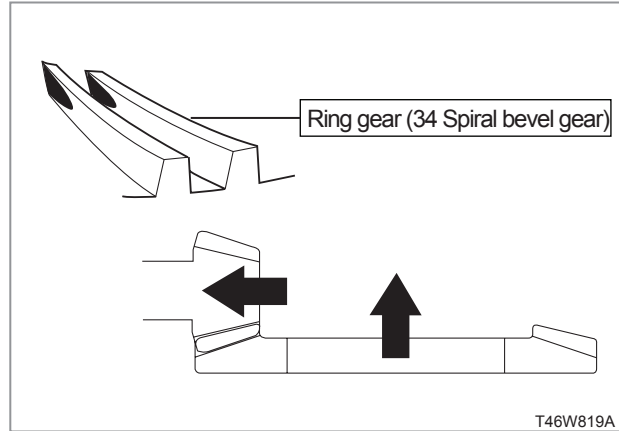

If the center of the contact mark is too close to the toe of the tooth, push back the pinion shaft and push in the ring gear to the pinion direction so that the back lash is maintained. Then, measure the backlash.

Increase in front shim (4) of pinion shaft (gear side)

- Decrease in rear shim (5)
- Increase in ring gear shim (2)
- Decrease in ring gear shim (3)

B. HEEL CONTACT

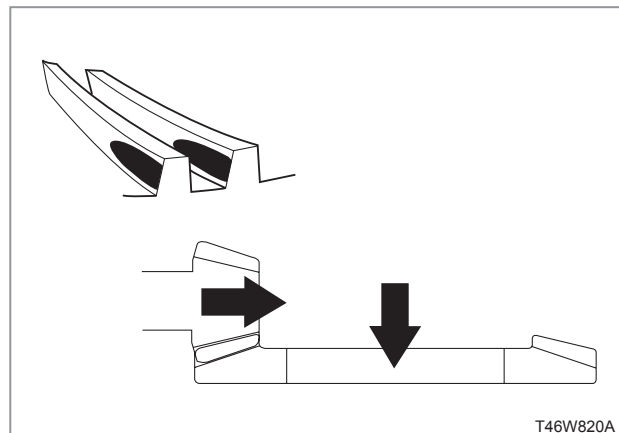

If the contact mark is close to the heel of the ring gear teeth, push the pinion shaft toward the ring gear and push the ring gear away from the pinion so that the backlash is maintained. Then, measure the backlash.

Decrease in front shim (4) of pinion shaft (gear side)

- Increase in rear shim (5)
- Decrease in ring gear shim (2)
- Increase in ring gear shim (3)

SAFETY FIRST
GENERAL
ENGINE
CVT
TRANSMISSION
CHASSIS
REAR AXLE
BRAKE
FRONT AXLE
STEERING
HYDRAULIC
ELECTRIC
INDEX

SAFETY FIRST

GENERAL

ENGINE

CVT

TRANSMISSION

CHASSIS

REAR AXLE

BRAKE

FRONT AXLE

STEERING

HYDRAULIC

ELECTRIC

INDEX

C. DEEP CONTACT

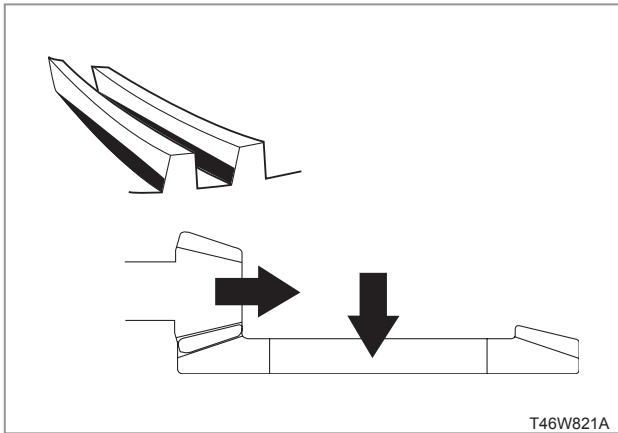

T46W821A

If the contact mark is deep into the ring gear teeth, push the ring gear away from the pinion. If necessary, push the pinion toward the ring gear to maintain the backlash. Then, measure the backlash for the final time.

- Decrease in ring gear shim (2)
- Increase in ring gear shim (3)
- Decrease in front shim (4) of pinion shaft (gear side)
- Increase in rear shim (5)

D. TIP CONTACT

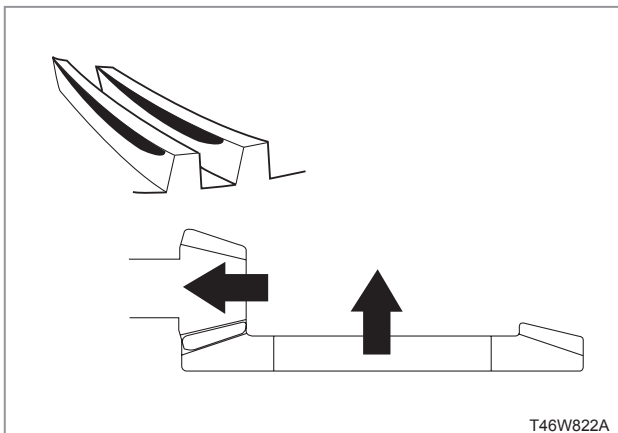

T46W822A

If the contact mark is on the tip of the ring gear teeth, pull the ring gear toward the pinion. If necessary, pull the pinion shaft backward to maintain the backlash. Then, measure the backlash for the final time.

- Increase in ring gear shim (2)
- Decrease in ring gear shim (3)
- Increase in front shim (4) of pinion shaft (gear side)
- Decrease in rear shim (5)

4.6 DIFFERENTIAL SYSTEM CLEARANCE CHECK

4.6.1 DIFFERENTIAL PINION AND DIFFERENTIAL PINION SHAFT



UUVW809A



UUVW810A

- Measure the outer diameter of the differential pinion shaft and the inner diameter of the differential pinion.
- Check the clearance by comparing the measurement. If the clearance is outside the allowable limit, replace the components with new ones.

Differential pinion shaft O.D.	15.966 ~ 15.984 mm 0.6286 ~ 0.6293 in.
Differential pinion I.D.	16,000 ~ 16.018 mm 0.6299 ~ 0.6306 in.
Standard clearance	0.016 ~ 0.052 mm 0.00063 ~ 0.00204 in.
Allowable clearance	0.25 mm (0.00984 in.)

4.6.2 DIFFERENTIAL CASE, SPIRAL BEVEL GEAR AND DIFFERENTIAL SIDE GEAR



UUVW811A



UUVW812A



UUVW813A

- Measure the inner diameter of the differential case and spiral bevel gear as well as the outer diameter of the differential side gear. Then, compare these measurements.
- Check the clearance. If it is out of the specified limit, replace the components with new ones.

Differential case I.D.	Φ32.025 ~ Φ32.050 mm Φ1.2608 ~ Φ1.2618 (in.)
Differential side gear O.D.	Φ31.959 ~ Φ31.975 mm Φ1.2582 ~ Φ1.2589 (in.)
Standard clearance	0.05 ~ 0.091 mm 0.00197 ~ 0.00358 in.
Allowable clearance	0.25 mm (0.00984 in.)

5. DISASSEMBLY, SERVICE AND ASSEMBLY

5.1 CV JOINT REMOVAL



M24W902A

1. Park the vehicle on firm and level ground, stop the engine and apply the parking brake. Then, unscrew the front axle drain plug (1) to drain the oil.



M24W903A

2. Support the bottom of the front frame with a hydraulic jack or stand and unscrew the mounting nuts (1) to remove the front wheel.

Front wheel (nut)
tightening torque 76.4 ~ 78.4 Nm
7.8 ~ 8.0 kgf-m
56.2 ~ 57.6 lb-ft

SAFETY FIRST
GENERAL
ENGINE
CVT
TRANSMISSION
CHASSIS
REAR AXLE
BRAKE
FRONT AXLE
STEERING
HYDRAULIC
ELECTRIC
INDEX

SAFETY FIRST

GENERAL

ENGINE

CVT

TRANSMISSION

CHASSIS

REAR AXLE

BRAKE

FRONT AXLE

STEERING

HYDRAULIC

ELECTRIC

INDEX



M24W904A



M24W906A

3. Unscrew the brake caliper mounting bolts (1) (M8, 2 EA) to remove the brake caliper (2).

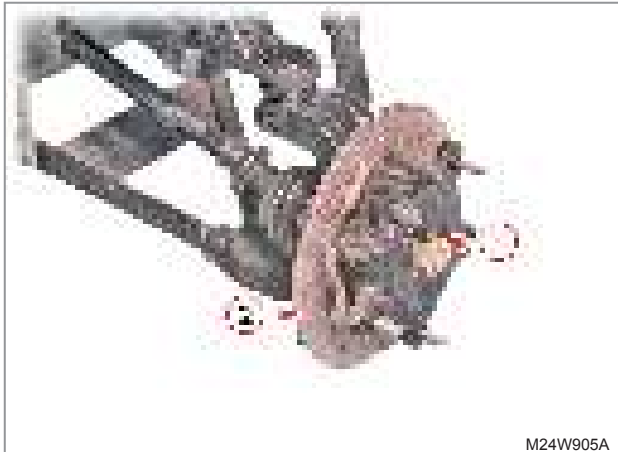

M24W905A



M24W907A

4. Remove the split pin and slotted nut (1). Then, tap the brake disc assembly (2) forward gently to remove it as one unit.

Slotted nut
tightening torque 93.1 ~ 98.0 Nm
9.5 ~ 10.0 kgf-m
68.4 ~ 72.0 lb-ft



M24W908A

5. Unscrew the nut (1) under the tie rod end mounting and the front knuckle mounting bolts (2) to separate the tie rod end and lower arm. Then, remove the knuckle arm (3).

5.2 CV JOINT BOOT REPLACEMENT

! IMPORTANT

- When installing the tie rod end mounting bolt, tighten the nut to the specified torque.

Slotted nut
tightening torque98.0 Nm
10.0 kgf-m
72.0 lb-ft

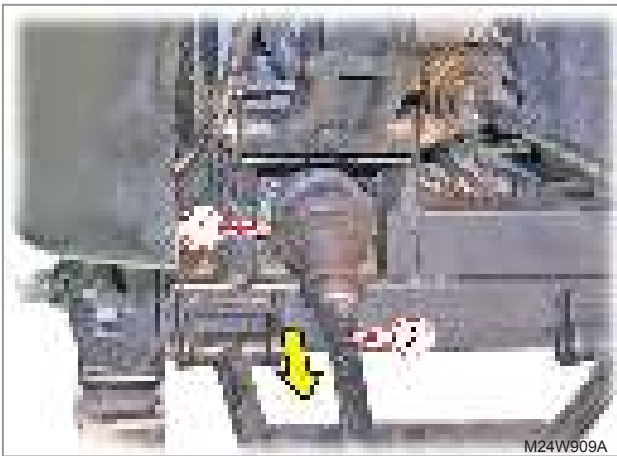

6. Unscrew the front axle drive shaft bearing holder mounting bolts (1) (M8, 3 EA) using the 12 mm socket wrench and pull the front axle drive shaft (2) to remove it as an assembly.



1. Remove the O-ring (1) and snap ring (2) from the front axle drive shaft assembly. Then, tap the bearing holder to remove the ball bearing (3) and bearing holder (4).

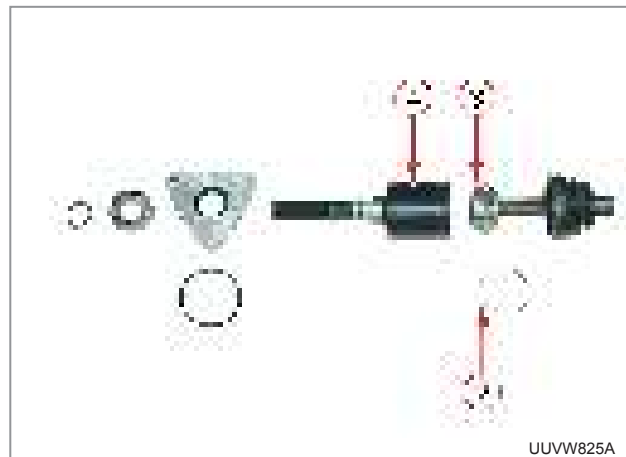

2. Undo the rubber bellows mounting band (1) and remove the rubber bellows. Then, remove the stop ring (2) from the opening of the drive shaft housing to remove the ball joint (3) as one unit.

SAFETY FIRST
GENERAL
ENGINE
CVT
TRANSMISSION
CHASSIS
REAR AXLE
BRAKE
FRONT AXLE
STEERING
HYDRAULIC
ELECTRIC
INDEX

! IMPORTANT

- During installation, make sure that the larger opening of the CV joint (3) cup is inserted into the housing (4) first. Otherwise, the bending angle of the joint is insufficient, leading to breakage.

REMARK

- Drive shaft boot band removal



1. The band can be disconnected by unfolding its bending section, unfolding its outer part and pushing it in the opposite direction of winding.



2. The band can be installed by aligning it with the boot groove, pulling and tightening its outer part, folding and inserting it to the bending section and folding the bending section to secure this outer part.

3. If necessary, pull out the snap ring and remove the ball joint guide, case, ball and rubber bellows in order. (Refer to "Rear axle drive shaft disassembly" in this chapter.)
4. For reassembly, fit the rubber boot to the shaft, insert the CV joint cup, fit the guide and fit the snap ring. Then, fit the ball into the hole, push it in along the housing groove and fit the stop ring.

! IMPORTANT

- During assembly, fill the drive shaft housing with a sufficient amount of grease. Make sure to apply grease to the ball not to miss it when installing it to the case.
- When installing the bearing holder, be careful not to damage the oil seal. If a new bearing holder is used, apply grease to its mating surface for the O-ring and oil seal.

5. Fit the rubber bellows to the housing and secure it with the band.

REMARK

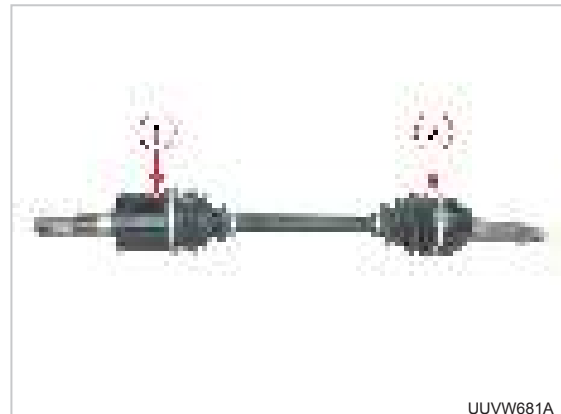

- Components of CV joint boot kit: boot, band and grease
- Each EV joint has two boot kits.
- The CV joint on the wheel side (1) is pressed in and cannot be removed.
- To replace the boot, remove the joint on the axle case side (2) and remove the two boots.

5.3 FRONT AXLE CASE REMOVAL

1. Remove the front wheels. Then, remove the front axle drive shaft assemblies (LH/RH). (For the removal procedures, refer to "5.1 Front axle disassembly.")

! IMPORTANT

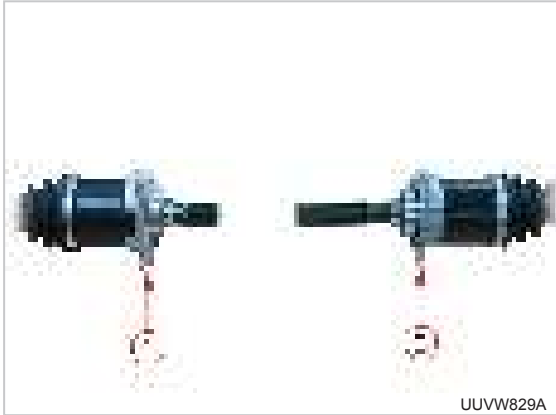

UUVW829A

- As the front axle drive shafts for the left (1) and right (2) are different, be careful not to mix them.

2. Remove the steering gearbox assembly. (Refer to the instruction for "Steering gearbox")

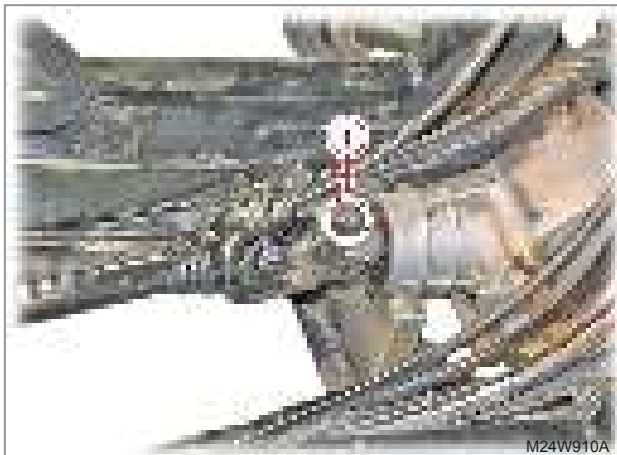

M24W910A

3. Remove the propeller shaft mounting spring pin (1) on the front axle case side by tapping it. Then, remove the propeller shaft (2) by pulling toward the transmission case.

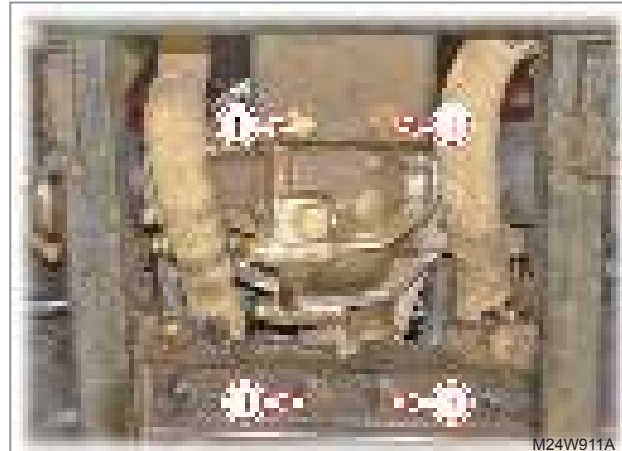

M24W911A

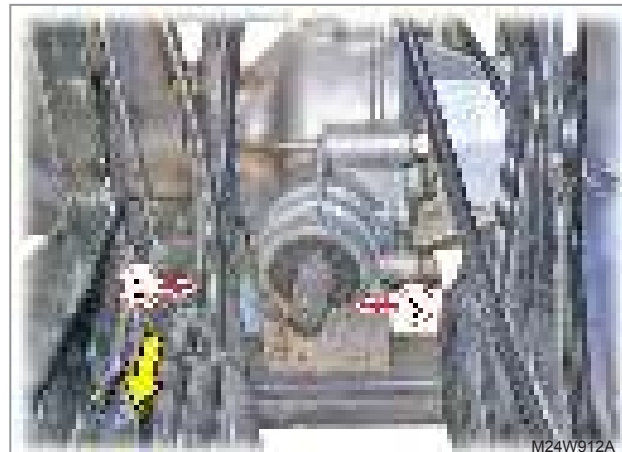

M24W912A



M24W913A

4. Unscrew the mounting bolts (1) (M10, 4 EA) from the lower section of the front axle case and disconnect the bleeder hose (2). Then, remove the front axle case assembly (3) by pulling toward the transmission case.

SAFETY FIRST

GENERAL

ENGINE

CVT

TRANSMISSION

CHASSIS

REAR AXLE

BRAKE

FRONT AXLE

STEERING

HYDRAULIC

ELECTRIC

INDEX

5.4 FRONT AXLE CASE DISASSEMBLY AND ASSEMBLY



1. Unscrew the front axle case mounting bolts (1) (M10, 7 EA). (14 mm socket wrench)

Bolt (1)
 specified torque..... 39.2 ~ 44.1 Nm
 4.0 ~ 4.5 kgf-m
 28.8 ~ 32.4 lb-ft

Bolt (2)
 specified torque..... 14.7 ~ 19.6 Nm
 1.5 ~ 2.0 kgf-m
 10.8 ~ 14.4 lb-ft

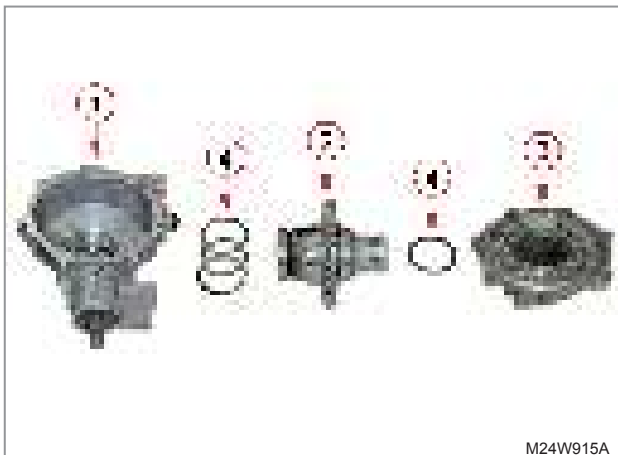
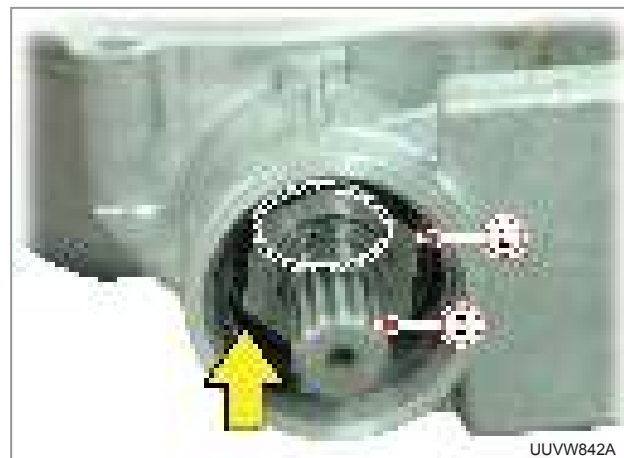

2. Remove the front axle case (1), differential system assembly (2), front axle case cover (3) and adjusting shim (4) in order. During assembly, make sure to keep the adjusting shim (4) in the original position.

REMARK

- When installing the front axle case and front axle case cover, apply DOW CORNING ® 737 or equivalent liquid gasket to the mating surfaces.

3. Pull out the oil seal (1) and unfold the staking part of the staking nut and unscrew the caulking nut (2). Then, tap the spiral bevel pinion shaft from outside inward to remove the bevel pinion shaft (3). If necessary, remove the taper roller bearing. When reassembling them, replace the oil seal with a new one and apply grease to its mating surface.
4. Assemble in the reverse order of disassembly.
5. When installing the spiral bevel pinion shaft, apply transmission oil to the taper roller bearing. Then, tighten the caulking nut to turning torque of the spiral bevel pinion shaft to 0.04 ~ 0.06 kgf-m.
6. Check the backlash and tooth contact between the spiral bevel gear and pinion, and use suitable adjusting collar.
7. When installing the oil seal, make sure to install it in the correct direction (lip should face inside). Apply grease to the lip of the oil seal and install it with a jig.

5.5 DIFFERENTIAL SYSTEM DISASSEMBLY AND ASSEMBLY

5.5.1 DIFFERENTIAL SYSTEM DISASSEMBLY



UUVW843A

1. Remove the clutch assembly (1) from the front differential assembly.



UUVW845A



UUVW844A

2. Remove the ball bearing (1) from the front differential assembly.



UUVW846A

3. Unscrew the spiral bevel gear mounting bolts (1) (M8, 6 EA) with the 12 mm socket wrench and remove the spiral bevel gear (2) and differential case (3) by tapping them with a rubber hammer.



UUVW847A

4. Pull out the differential pinion shaft (1) and remove the differential pinions (2) and differential pinion washers (3). Then, remove the side gear (5) and differential washer (6) from the spiral bevel gear (4) and the side gear (8) and differential washer (9) from the differential case (7).

SAFETY FIRST

GENERAL

ENGINE

CVT

TRANSMISSION

CHASSIS

REAR AXLE

BRAKE

FRONT AXLE

STEERING

HYDRAULIC

ELECTRIC

INDEX

5.5.2 DIFFERENTIAL SYSTEM ASSEMBLY



UUVW848A

1. Fit the straight pin (1) and knock pin (2) into the spiral bevel gear.



UUVW851A

4. Insert the differential washer (1) and side gear (2) into the spiral bevel gear.



UUVW849A

2. Insert the differential washer (1) and side gear (2) into the differential case.



UUVW852A

5. Install the spiral bevel gear to the differential case and tighten the mounting bolts (1) diagonally to the specified torque in several steps. Make sure to apply adhesive LOCTITE 271 (RED) or equivalent to their threads.

Bolt (M8) specified
 torque 29.4 ~ 34.3 Nm
 3.0 ~ 3.5 kgf-m
 21.6 ~ 25.2 lb-ft



UUVW850A

3. After inserting the differential pinion washer (1) and differential pinion (2) to the differential case, fit the differential pinion shaft (3) with its hole facing up. Then, insert the differential pinion (4) and differential pinion washer (5).

REMARK

- When installing the differential system, apply molybden disulphide to each moving part. (Three Bond 1901 or equivalent)

5.6 LSD DISASSEMBLY AND ASSEMBLY



6. Tap the ball bearings (1) onto the front and back.



1. Take out the snap ring (1).



7. Tap the clutch assembly into the case with a rubber hammer.

! IMPORTANT

UUVW856A

- When installing the snap ring to the clutch assembly, its opening should be between the protrusions of the case.

SAFETY FIRST
GENERAL
ENGINE
CVT
TRANSMISSION
CHASSIS
REAR AXLE
BRAKE
FRONT AXLE
STEERING
HYDRAULIC
ELECTRIC
INDEX

5.7 FRONT AXLE KNUCKLE ASSEMBLY
DISASSEMBLY AND ASSEMBLY

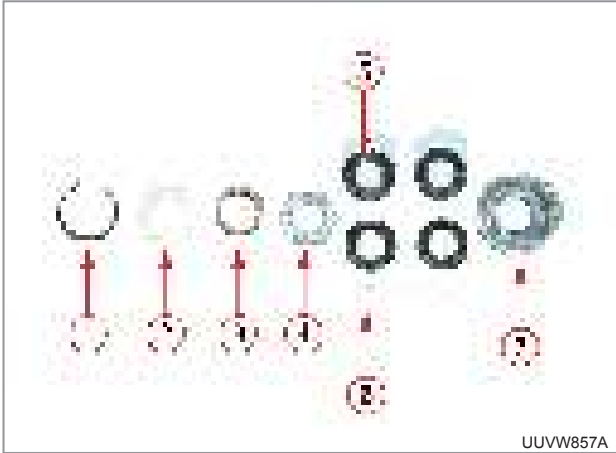

2. Remove the spring seating plate (2), spring (3), spring seating plate (4), clutch discs (5), clutch plates (6) and case (7) in order.
3. Assemble in the reverse order of disassembly.
4. When installing the clutch plates, align their spline grooves.

REMARK

- When disassembling the clutch assembly, proper tools, such as a spring compressor, should be used to remove the snap ring due to high spring tension.



1. Remove the front tires (1).

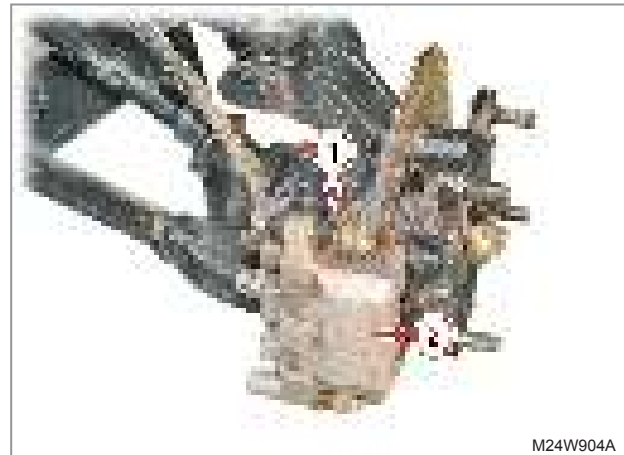

2. Unscrew the brake caliper mounting bolts (1) (M8, 2 EA) to remove the brake caliper (2).



3. Remove the split pin and slotted nut (1). Then, tap the brake disc assembly (2) forward gently to remove it as one unit.

Slotted nut

Tightening torque 93.1 ~ 98.0 Nm
9.5 ~ 10.0 kgf-m
68.4 ~ 72.0 lb-ft



M24W906A

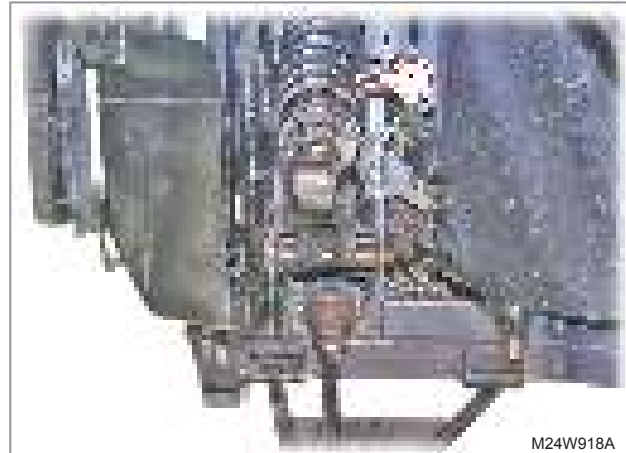

M24W918A



M24W908A



M24W919A

4. Unscrew the nut (1) under the tie rod end mounting and the front knuckle mounting bolt (2) to separate the tie rod end and lower arm. Then, remove the knuckle arm (3).

5. Remove the front strut assembly (1).
6. Install in the reverse order of removal.

SAFETY FIRST

GENERAL

ENGINE

CVT

TRANSMISSION

CHASSIS

REAR AXLE

BRAKE

FRONT AXLE

STEERING

HYDRAULIC

ELECTRIC

INDEX

! IMPORTANT



M24W923A

- During assembly, set the spring length "A" of the front strut assembly to be 401 ± 3 mm (15.79 ± 0.12 in.).

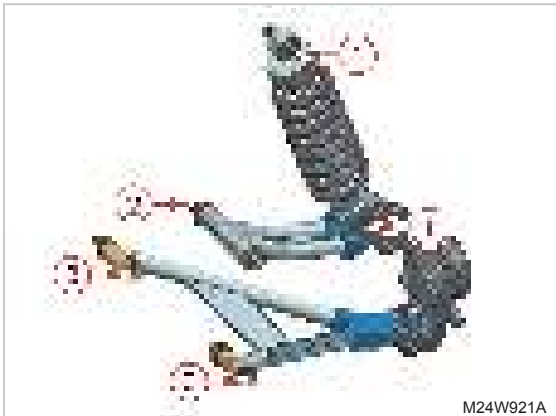

M24W921A

- When installing the front suspension, tighten each tightening section to the specified torque.
 - (1) 65 Nm, 6.6 kgf-m, 47.8 lb-ft
 - (2) 101 Nm, 10.3 kgf-m, 74.2 lb-ft
 - (3) 41 Nm, 4.2 kgf-m, 30.1 lb-ft

5.8 PROPELLER SHAFT (FRONT UNIVERSAL JOINT) REPLACEMENT

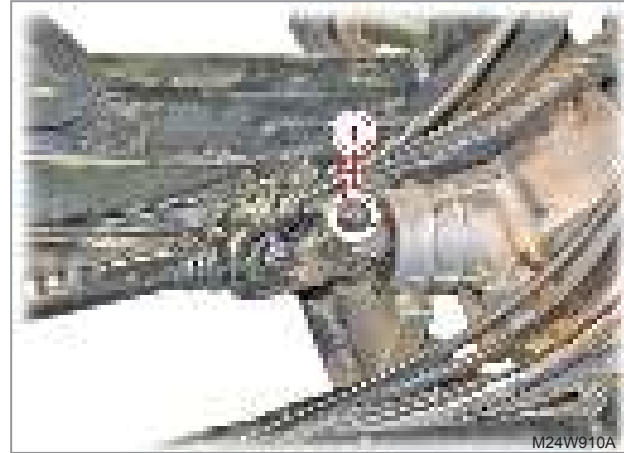

M24W910A

1. Tap the spring pin (1) of the propeller shaft joint which is connected to the front axle case shaft and remove the spring pin.



UUVW866A

2. Pull the propeller shaft toward the transmission to separate it from the front axle case. Then, remove it by pulling it toward the front axle case.

6. COMPONENTS AND JOB CODES

6.1 G250001 FRONT SUSPENSION GROUP (CVT)

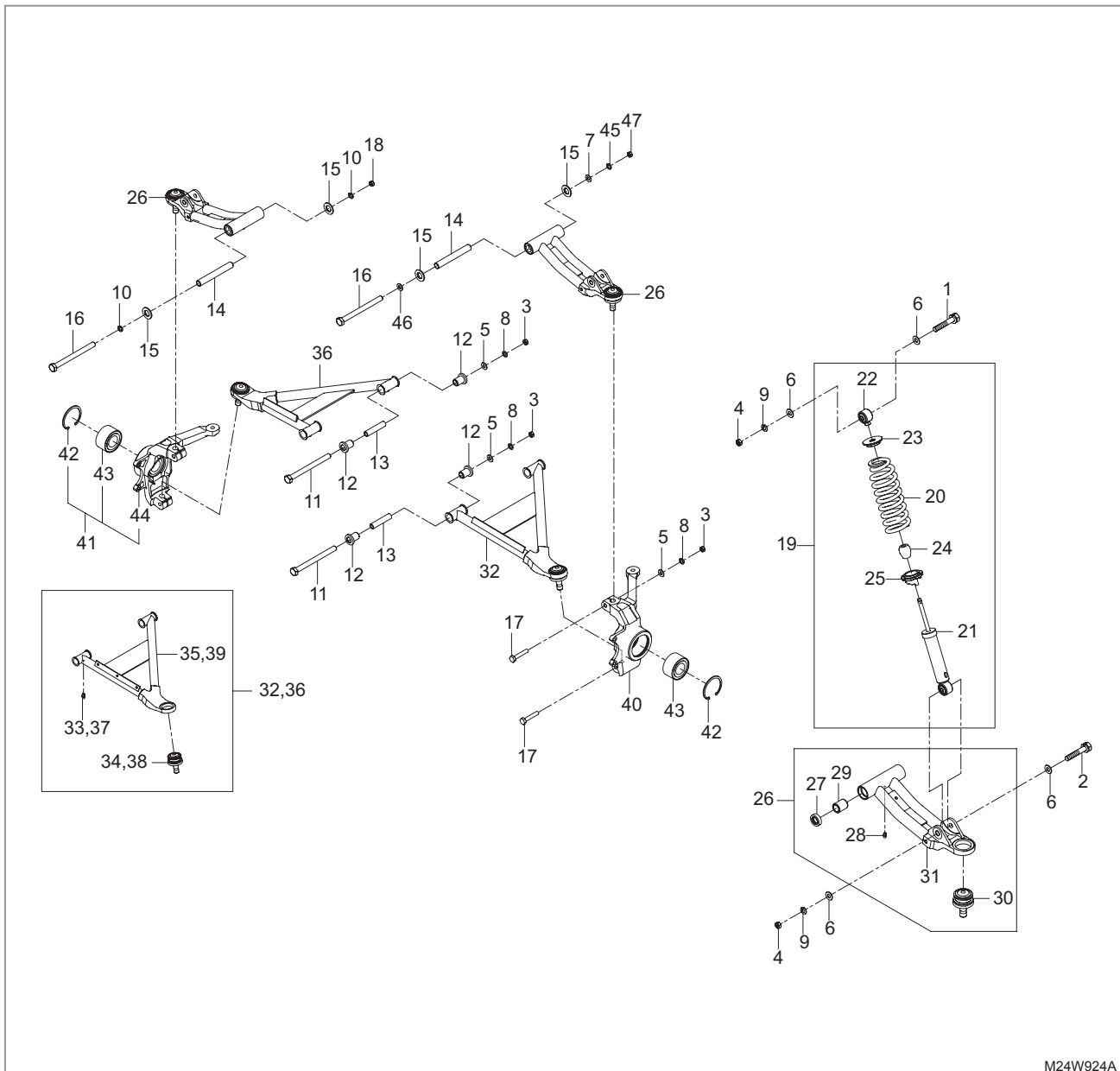

M24W924A

COMPONENTS AND JOB CODES

- | | | |
|-------------------------------|---|-------------------------------------|
| (1) Bolt, Washer | (17) Bolt | (33) Nipple (W040019) |
| (2) Bolt, Washer | (18) Nut, self Lock (M14x2.0) | (34) Ball Joint (W040020) |
| (3) Nut | (19) Strut Assy (W040005) | (35) LWR Arm Assy-LH (W040021) |
| (4) Nut | (20) Coil Spring, FRT (W040006) | (36) Arm Assy LWR, RH |
| (5) Plain_washer | (21) Strut Assy Complete, FRT (W040007) | (37) Nipple |
| (6) Plain_washer | (22) Shock UPR Bush Assy, FRT (W040008) | (38) Ball Joint |
| (7) Washer, Plain | (23) Spring Seat, UPR (W040009) | (39) LWR Arm Assy-RH |
| (8) Spring_washer | (24) Bumper Stopper (W040010) | (40) FRT Knuckle Assy, LH (W040026) |
| (9) Spring_washer | (25) Spring Seat, LWR (W040011) | (41) FRT Knuckle Assy-RH (W040027) |
| (10) Washer, Spring | (26) Arm Assy UPR, FRT (W040012) | (42) Ring, Snap |
| (11) Bolt | (27) Seal, Oil (W040013) | (43) Hub Bearing, FR (W040028) |
| (12) Bushing-arm (W040001) | (28) Nipple (W040014) | (44) Knuckle, RH |
| (13) Bush (W040002) | (29) UPR Arm Metal Bush (W040015) | (45) Washer, Spring |
| (14) Arm Pipe Bush UPR, Inner | (30) Ball Joint (W040016) | (46) Washer, Plain |
| (15) UPR Arm Spacer | (31) UPR Arm Knuckle Assy (W040017) | (47) Nut, self Lock (M14x2.0) |
| (16) Bolt (Strut UPR Arm) | (32) Arm Assy LWR, LH (W040018) | |

- SAFETY FIRST
- GENERAL
- ENGINE
- CVT
- TRANSMISSION
- CHASSIS
- REAR AXLE
- BRAKE
- FRONT AXLE**
- STEERING
- HYDRAULIC
- ELECTRIC
- INDEX

SAFETY FIRST

GENERAL

ENGINE

CVT

TRANSMISSION

CHASSIS

REAR AXLE

BRAKE

FRONT AXLE

STEERING

HYDRAULIC

ELECTRIC

INDEX

6.2 G130001 FRONT AXLE CASE GROUP

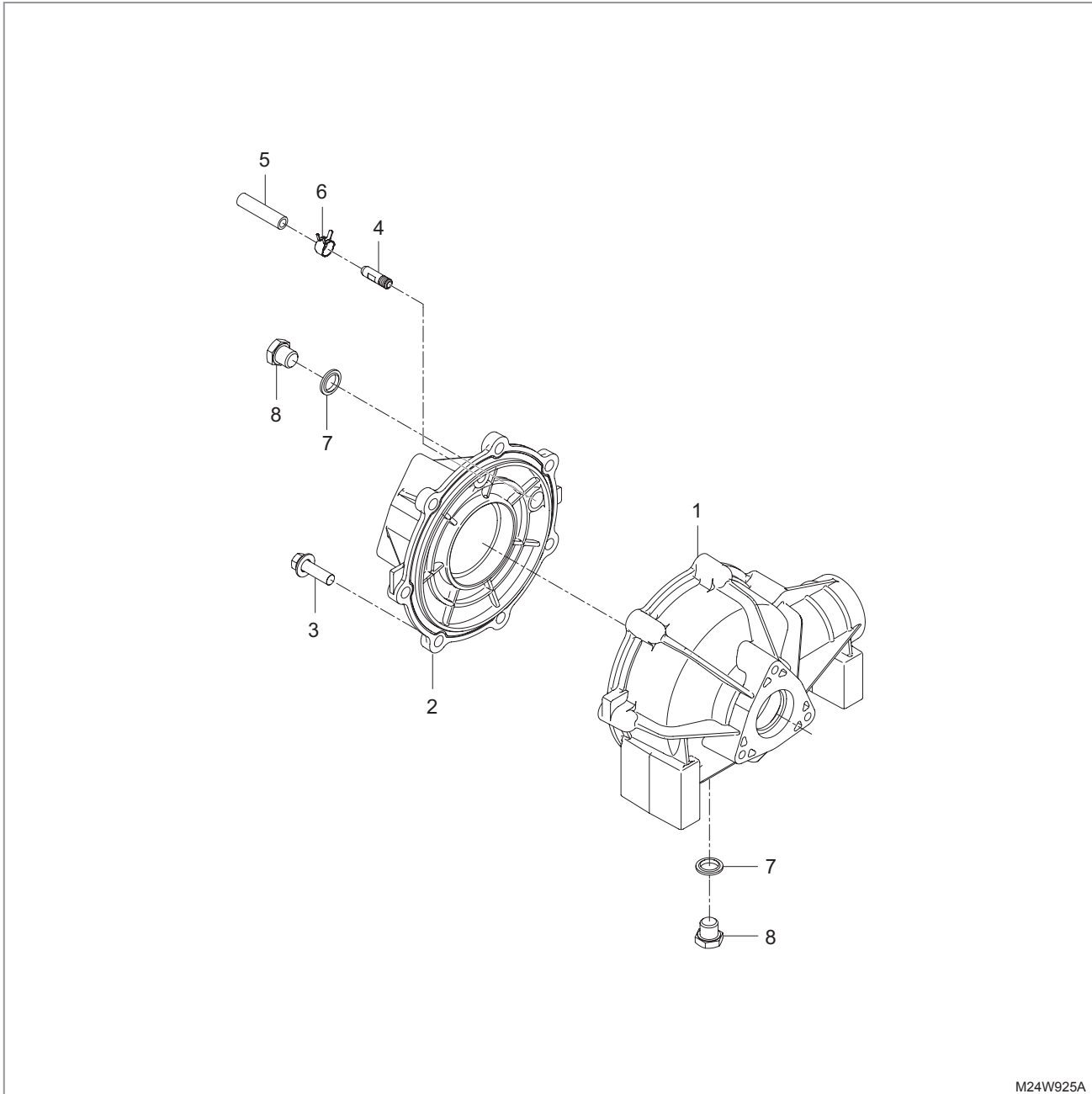

M24W925A

COMPONENTS AND JOB CODES

- | | |
|---------------------------------|------------------------------|
| (1) Case, Front Axle (M010002) | (5) Hose, Overflow (M010004) |
| (2) Cover, Front Case (M010003) | (6) Clip, Tube |
| (3) Bolt, Washer | (7) Washer, Seal |
| (4) Connector, Air Breather | (8) Plug (M010005) |

6.3 G132001 BEVEL PINION SHAFT GROUP

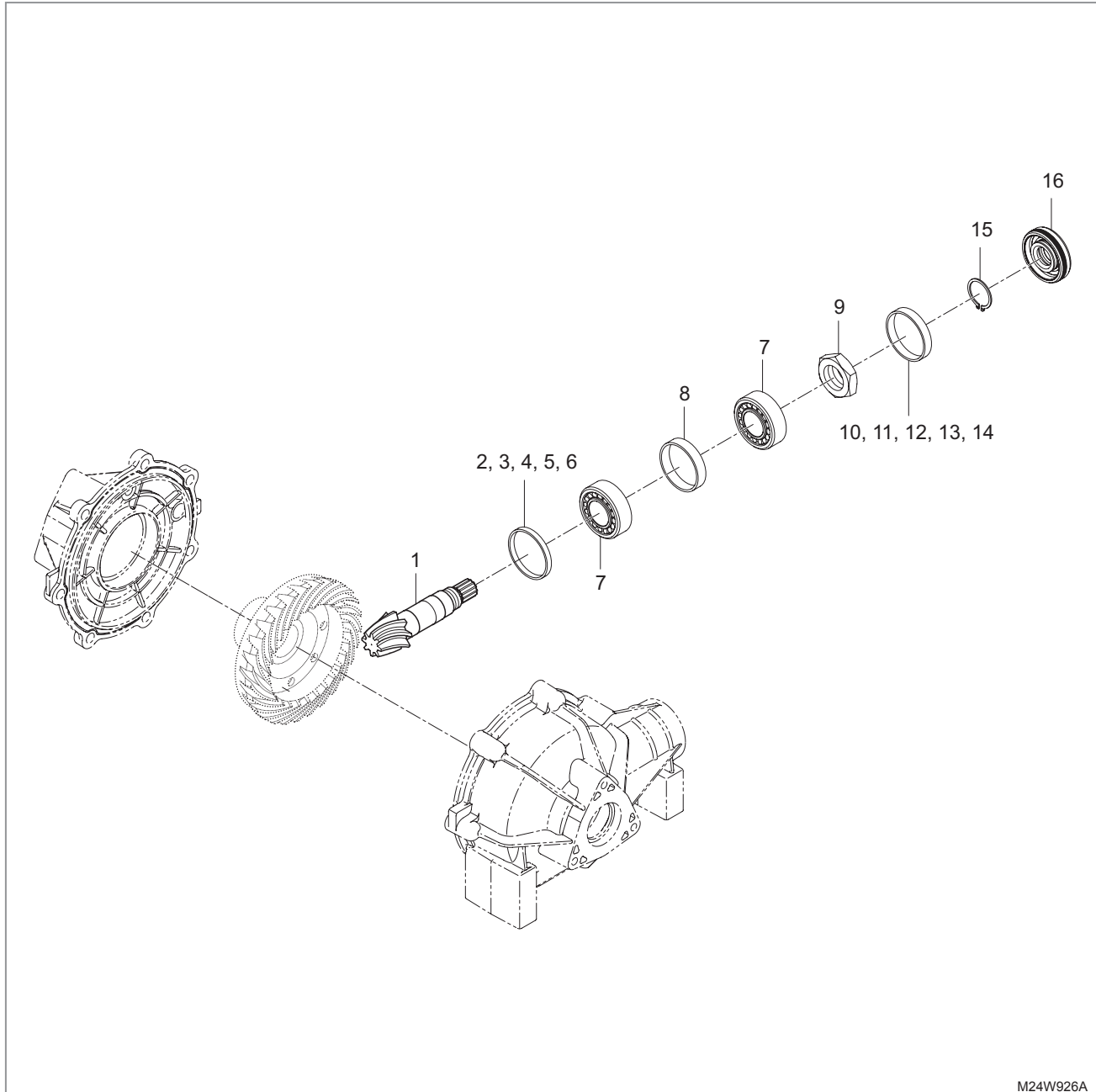

M24W926A

COMPONENTS AND JOB CODES

- | | |
|---|--|
| (1) Bevel Pinion Shaft 8 (M030001) | (9) Nut, 24 |
| (2) Collar, Axle Adjusting FR (M030002) | (10) Collar 2, Axle Adjusting FR (M030005) |
| (3) Collar, Axle Adjusting FR (M030002) | (11) Collar 2, Axle Adjusting FR (M030005) |
| (4) Collar, Axle Adjusting FR (M030002) | (12) Collar 2, Axle Adjusting FR (M030005) |
| (5) Collar, Axle Adjusting FR (M030002) | (13) Collar 2, Axle Adjusting FR |
| (6) Collar, Axle Adjusting FR (M030002) | (14) Collar 2, Axle Adjusting FR |
| (7) Bearing, Taper Roller (M030003) | (15) Snap Ring |
| (8) Spacer, 1 FR Axle (M030004) | (16) Seal, Oil |

SAFETY FIRST
GENERAL
ENGINE
CVT
TRANSMISSION
CHASSIS
REAR AXLE
BRAKE
FRONT AXLE
STEERING
HYDRAULIC
ELECTRIC
INDEX

SAFETY FIRST

GENERAL

ENGINE

CVT

TRANSMISSION

CHASSIS

REAR AXLE

BRAKE

FRONT AXLE

STEERING

HYDRAULIC

ELECTRIC

INDEX

6.4 G160001 4WD CV JOINT GROUP

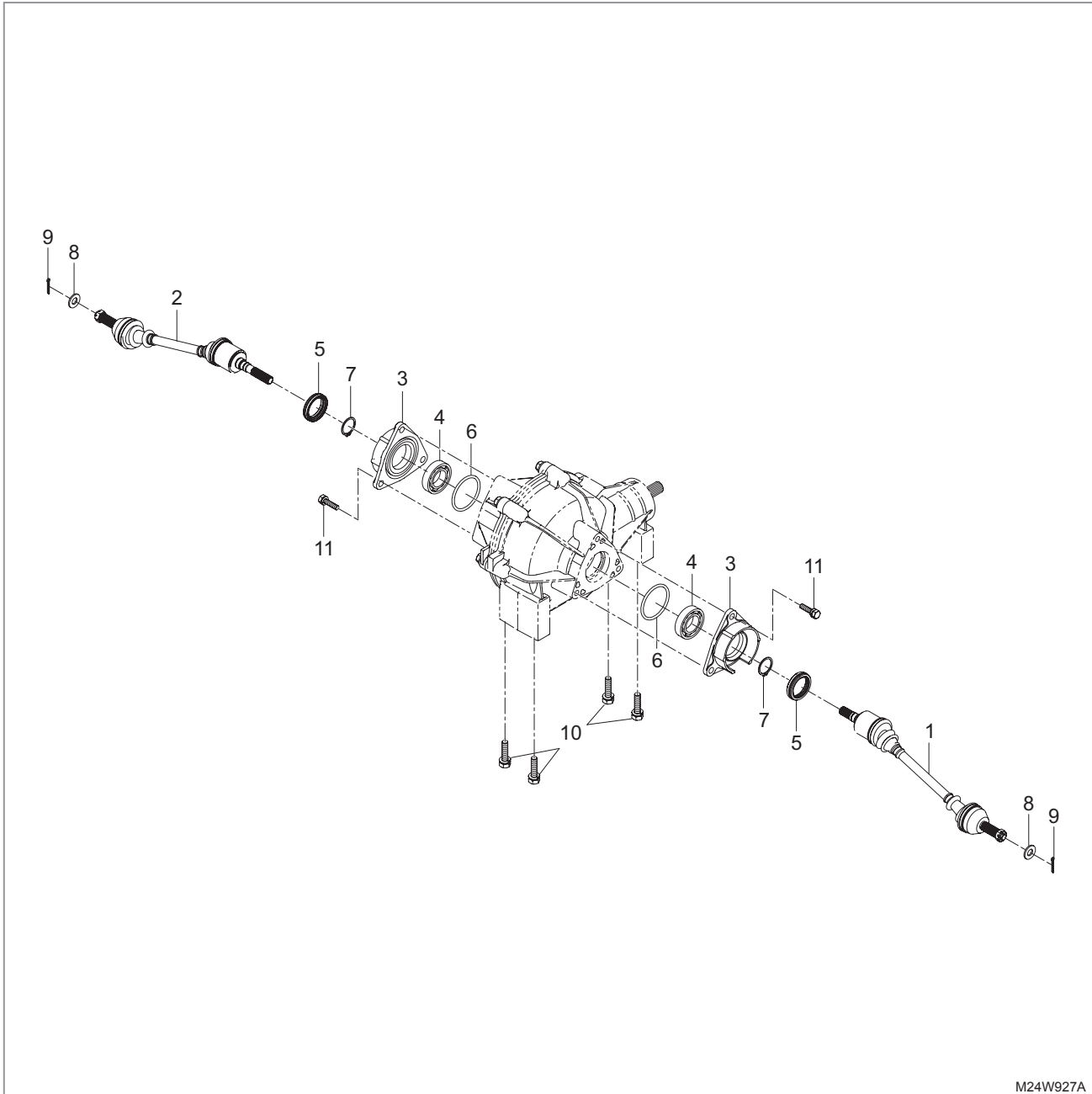

COMPONENTS AND JOB CODES

- | | |
|------------------------------------|-------------------|
| (1) Front Drive Shaft_LH (M180001) | (7) Snap Ring |
| (2) Front Drive Shaft_RH (M180002) | (8) Washer, Plain |
| (3) Holder, bearing (M180003) | (9) Pin, Split |
| (4) Ball Bearing (M180004) | (10) Bolt |
| (5) Oil Seal (30*40*8) (M180005) | (11) Bolt, Washer |
| (6) O Ring (M180006) | |

6.5 G131001 FRONT DIFF SYSTEM GROUP

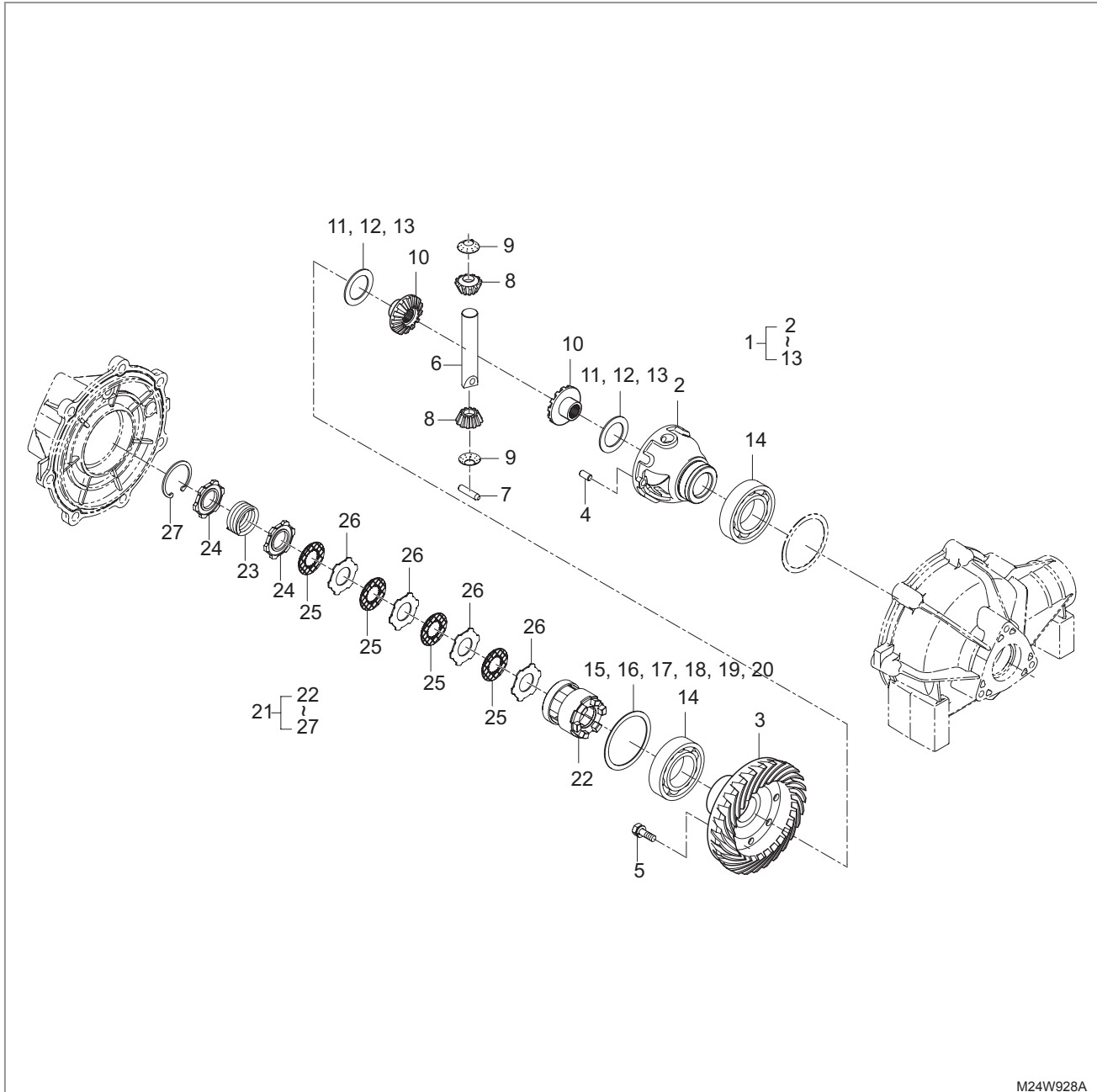

M24W928A

COMPONENTS AND JOB CODES

- | | |
|--|-------------------------------------|
| (1) Diff. Gear Case Assy, FR (M020001) | (15) Shim, 0.1 |
| (2) Case, Differential FR (M020002) | (16) Shim, 0.2 |
| (3) Gear, 34bevel (M020003) | (17) Shim, 0.4 |
| (4) Pin, Parallel | (18) Shim, 0.8 |
| (5) Bolt, Ubs | (19) Shim, 1.0 |
| (6) Shaft, Differential Pinion (M020004) | (20) Shim, 1.2 |
| (7) Pin, Parallel | (21) Clutch, LSD Assy (M020009) |
| (8) Pinion, Differential (M020005) | (22) Body, Clutch (M020010) |
| (9) Washer, Diff Pinion (M020006) | (23) Spring Clutch (M020011) |
| (10) Gear, Diff. Side (M020007) | (24) Sheet, Spring (T3.5) (M020012) |
| (11) Shim, 0.8 | (25) Disk, Clutch (M020013) |
| (12) Shim, 1.0 | (26) Plate, Clutch 1.5T (M020014) |
| (13) Shim, 1.2 (M020008) | (27) Snap Ring |
| (14) Ball Bearing | |

SAFETY FIRST
GENERAL
ENGINE
CVT
TRANSMISSION
CHASSIS
REAR AXLE
BRAKE
FRONT AXLE
STEERING
HYDRAULIC
ELECTRIC
INDEX

MEMO

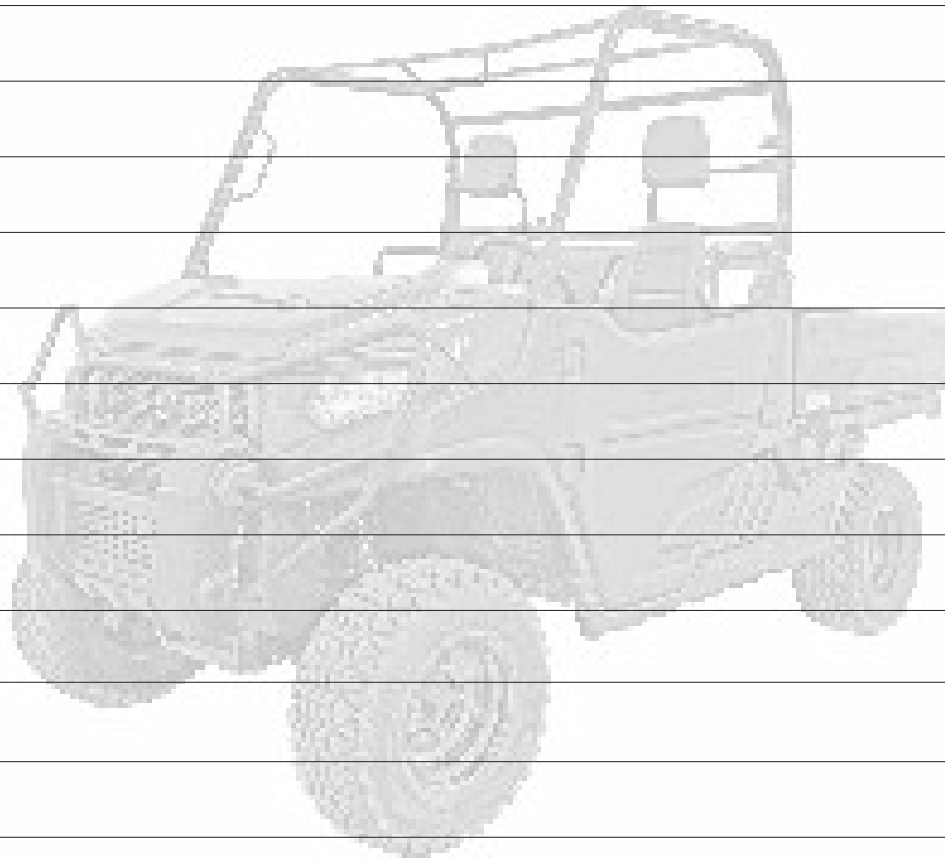



**K9 2400
K9 2440**

STEERING SYSTEM

CHAPTER 10

TABLE OF CONTENTS

1. SPECIFICATIONS	10-2	4. INSPECTION AND ADJUSTMENT	10-8
1.1 Steering gearbox	10-2	4.1 Tie-rod length adjustment	10-8
1.2 Tightening torque	10-2	4.2 Toe-in adjustment	10-8
2. STRUCTURE AND FUNCTION	10-3	5. DISASSEMBLY, SERVICE AND ASSEMBLY	10-9
2.1 Operating system diagram	10-3	5.1 Steering gearbox removal and disassembly	10-9
2.2 Structure in steering gearbox	10-4	6. COMPONENTS	10-16
2.3 Steering gearbox components	10-5	6.1 G220002 Steering group (USA)	10-16
2.4 Internal structure of torque generator ..	10-6	6.2 G531002 Power steering unit group	10-17
3. TROUBLESHOOTING	10-7		

SAFETY FIRST

1. SPECIFICATIONS

1.1 STEERING GEARBOX

Item	Specifications
Type	Hydraulic (Torque generator)
Distance from tie rod end to end (from center of ball)	934.8 ± 1.5 mm (36.803 ± 0.059 in.)
Average turning torque	1 ~ 1.5 Nm (0.102 ~ 0.153 kgf-m, 0.735 ~ 1.102 lb-ft)
Rotating ratio (rack moving distance / pinion shaft rotation)	32.52 mm/rev (1.28 in./rev)
Steering wheel revolution (factory spec.)	3.69 turns

GENERAL

ENGINE

CVT

TRANSMISSION

CHASSIS

REAR AXLE

1.2 TIGHTENING TORQUE

Position	Size	Tightening torque
Steering wheel mounting nut	M12	48.0 ~ 55.9 Nm 4.9 ~ 5.7 kgf-m 35.3 ~ 41.0 lb-ft
Slotted tie rod end mounting nut	-	98 Nm 10 kgf-m 72 lb-ft
Steering gearbox mounting bolt	M8	25.0 Nm 2.55 kgf-m 18.37 lb-ft

BRAKE

FRONT AXLE

STEERING

HYDRAULIC

ELECTRIC

INDEX

- SAFETY FIRST
- GENERAL
- ENGINE
- CVT
- TRANSMISSION
- CHASSIS
- REAR AXLE
- BRAKE
- FRONT AXLE
- STEERING**
- HYDRAULIC
- ELECTRIC
- INDEX

2.2 STRUCTURE IN STEERING GEARBOX

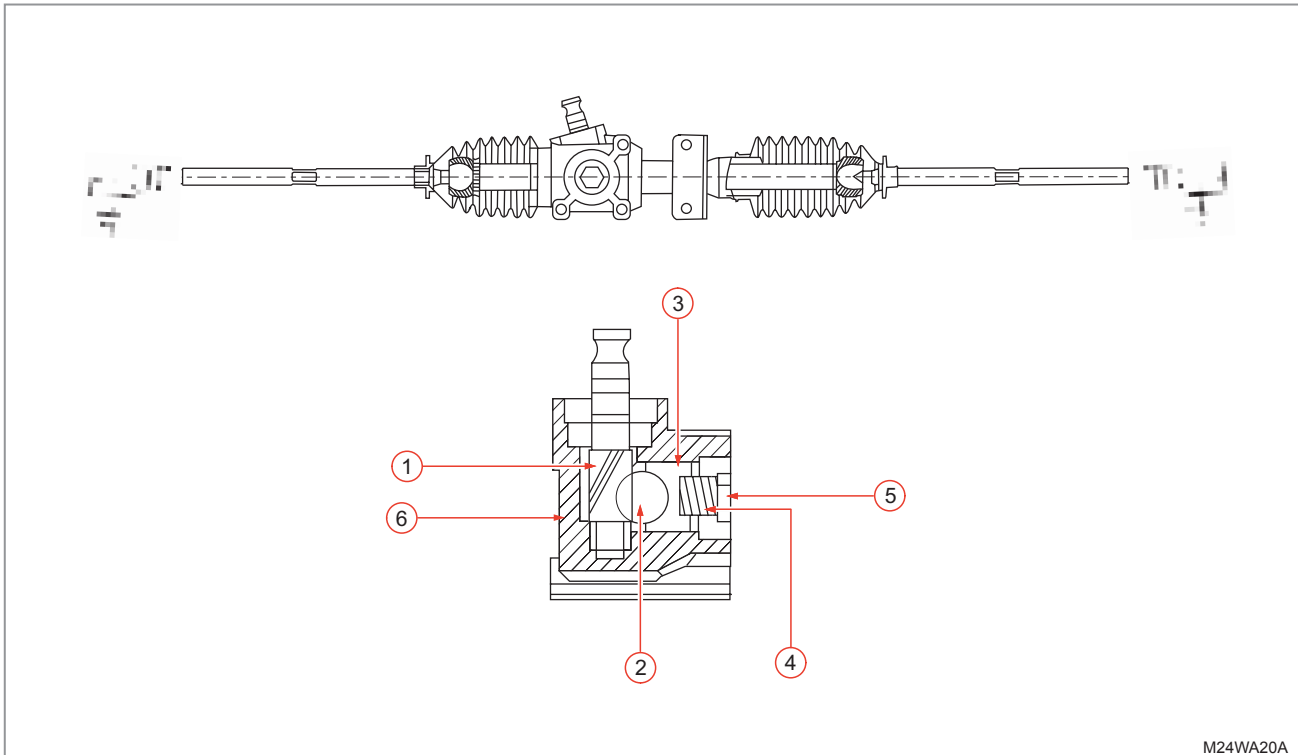

- | | | |
|------------------|------------------|------------------|
| (1) Pinion shaft | (3) Rack support | (5) Plug |
| (2) Rack | (4) Spring | (6) Gearbox body |

In the steering gearbox, the pinion is engaged with the rack. When the pinion rotates, the rack moves to the side in a linear motion.

2.3 STEERING GEARBOX COMPONENTS

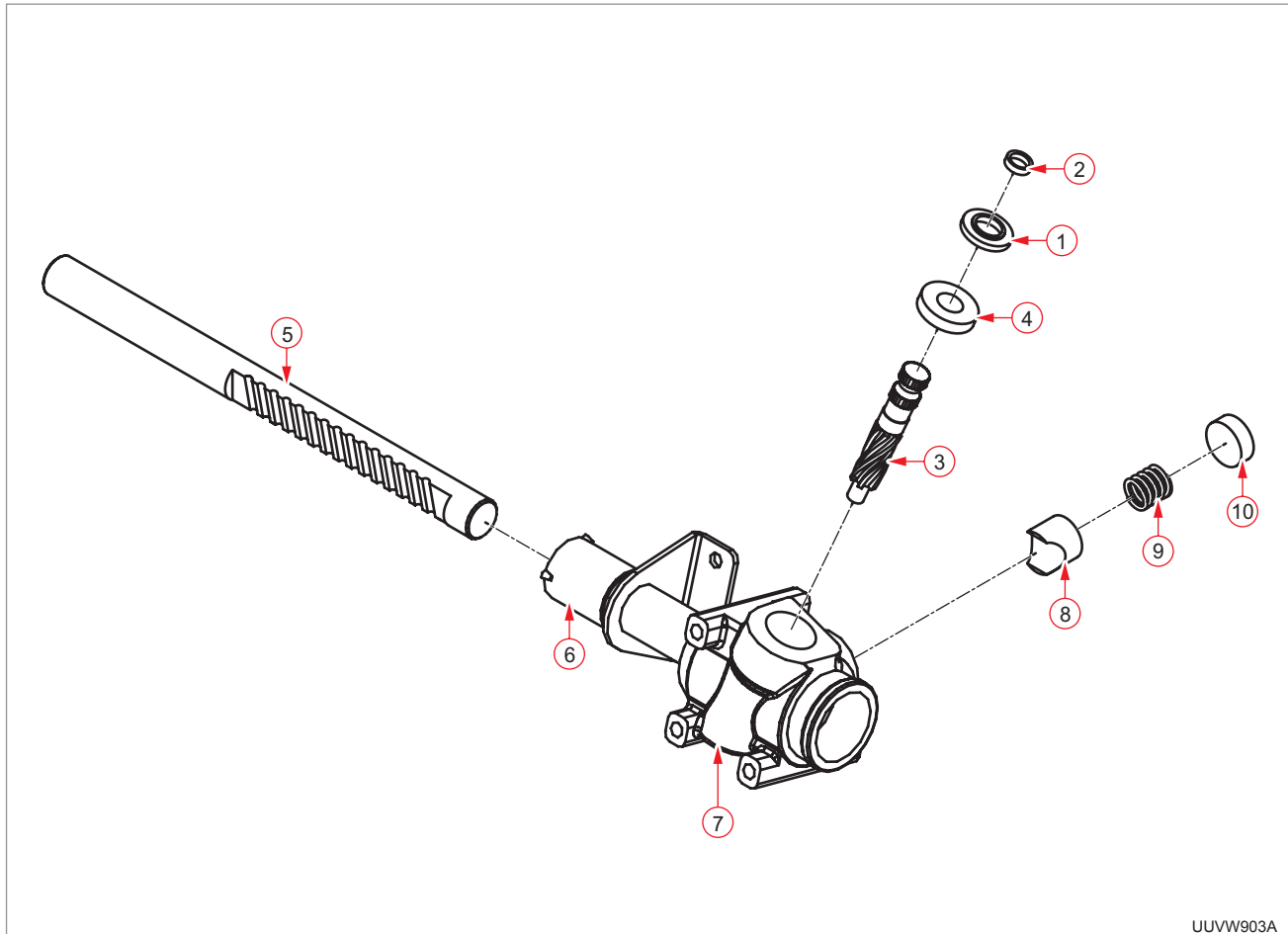

UUVW903A

- (1) Plug
- (2) Oil seal
- (3) Pinion shaft
- (4) Ball bearing

- (5) Rack
- (6) Rack guide
- (7) Steering gearbox
- (8) Rack support

- (9) Spring
- (10) Plug

SAFETY FIRST
GENERAL
ENGINE
CVT
TRANSMISSION
CHASSIS
REAR AXLE
BRAKE
FRONT AXLE
STEERING
HYDRAULIC
ELECTRIC
INDEX

2.4 INTERNAL STRUCTURE OF TORQUE GENERATOR

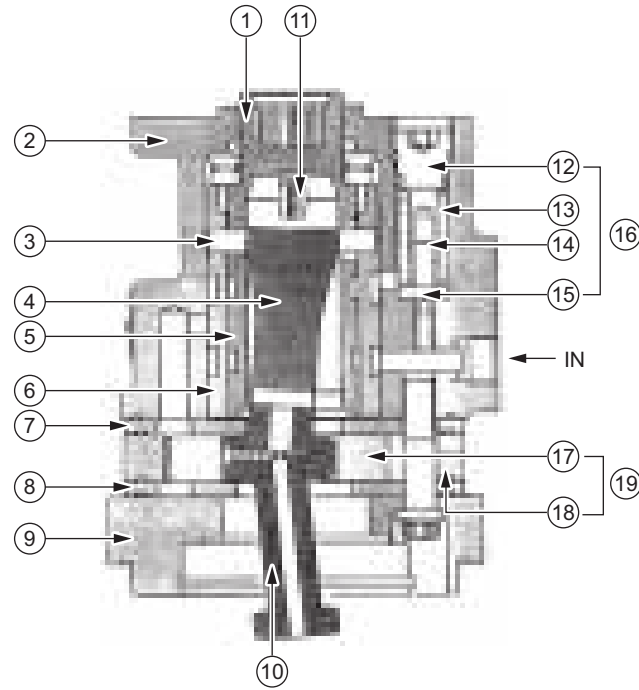

457W505A

- | | | |
|--------------------|-----------------------|-----------------------|
| (1) Input shaft | (8) Spacer plate 2 | (15) Relief poppet |
| (2) Valve housing | (9) Flange | (16) Relief valve |
| (3) Pin | (10) Power end drive | (17) Gerotor star |
| (4) Control drive | (11) Centering spring | (18) Gerotor ring |
| (5) Spool | (12) Adjust plug | (19) Gerotor assembly |
| (6) Sleeve | (13) Relief spring | |
| (7) Spacer plate 1 | (14) Damper collar | |

The control valve unit consists of the input shaft (spool), sleeve, housing, relief valve, etc. With a little operating force enough to displace the centering spring, it can switch the oil flow. As the control valve switches, hydraulic oil at high pressure supplied from the gear pump is delivered to the Gerotor through the inlet port. The Gerotor works as a hydraulic motor and generates a high torque value at the output shaft (power end drive). After achieving its goal, the hydraulic oil is delivered from the outlet port to the control valve. Also, even though the engine stops or the hydraulic pump is not working properly, manual operation is still possible without a hydraulic oil source since the power is mechanically transferred from the input shaft to the output shaft.

SAFETY FIRST

GENERAL

ENGINE

CVT

TRANSMISSION

CHASSIS

REAR AXLE

BRAKE

FRONT AXLE

STEERING

HYDRAULIC

ELECTRIC

INDEX

3. TROUBLESHOOTING

Symptom	Cause	Solution
Vehicle pulls to right or left	<ul style="list-style-type: none"> • Improper front tire size, inflation pressure or shape • Worn or damaged tie rod end • Improper toe-in 	<ul style="list-style-type: none"> • Adjust the inflation pressure or replace the tires • Replace • Adjust
Excessive steering wheel reaction	<ul style="list-style-type: none"> • Worn or damaged tie rod end • Improper toe-in • Damaged front axle 	<ul style="list-style-type: none"> • Replace • Adjust • Replace
Steering wheel vibrates	<ul style="list-style-type: none"> • Abnormally worn tire, abnormal size or low inflation pressure • Damaged gearbox bearing or gear 	<ul style="list-style-type: none"> • Repair and replace • Replace
Abnormal noise	<ul style="list-style-type: none"> • Worn steering gearbox gear • Insufficient hydraulic oil 	<ul style="list-style-type: none"> • Replace • Add oil.
Heavy steering wheel	<ul style="list-style-type: none"> • Seized, damaged or worn torque generator • Insufficient hydraulic oil 	<ul style="list-style-type: none"> • Replace • Add oil.

- SAFETY FIRST
- GENERAL
- ENGINE
- CVT
- TRANSMISSION
- CHASSIS
- REAR AXLE
- BRAKE
- FRONT AXLE
- STEERING**
- HYDRAULIC
- ELECTRIC
- INDEX

4. INSPECTION AND ADJUSTMENT

4.1 TIE-ROD LENGTH ADJUSTMENT

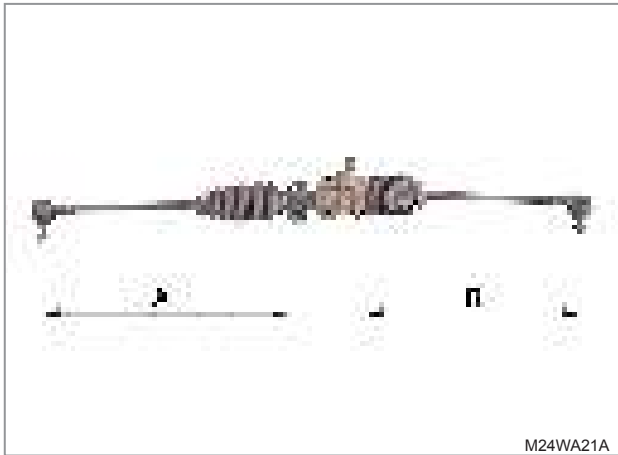

- When installing the steering gearbox assembly to the vehicle, the tie-rod length A and B should be set correctly in advance.
A : 436.6 mm (17.19 in.)
B : 398.3 mm (15.68 in.)

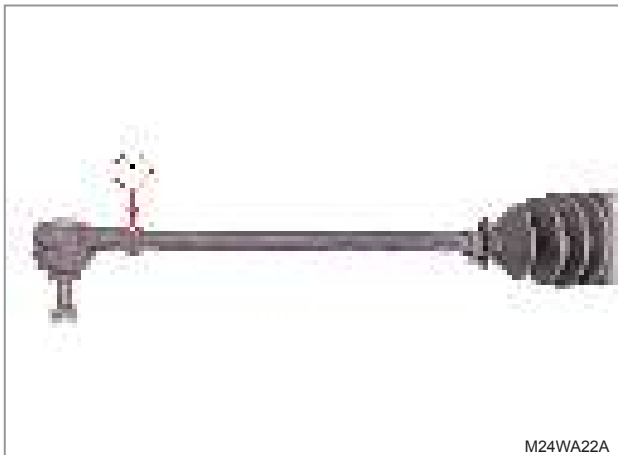

- Unscrew the tie-rod end mounting nut (1), turn the tie-rod end to set its length correctly, and tighten the mounting nut firmly.

4.2 TOE-IN ADJUSTMENT

- Adjust the toe-in so that the distance between the front of the front wheels is 2 ~ 8 mm (0.079 ~ 0.315 in.) shorter than the distance between the rear of the front wheels.
- To adjust the distance, unscrew the tie-rod end mounting nut and turn the tie-rod end.
- For detailed instructions, refer to "Toe-in adjustment" in chapter 9 "Front Axle."

5. DISASSEMBLY, SERVICE AND ASSEMBLY

5.1 STEERING GEARBOX REMOVAL AND DISASSEMBLY



1. After removing the steering wheel (1), remove the front wheel drive lever grip (2), differential lock lever grip (3) and shift lever grip (4).



2. Unscrew the screws (1) to remove the tilt cover (2). Then, unscrew the combination switch mounting bolts (3) to remove the combination switch (4).



3. Remove the instrument panel assembly (1) and glove block cover assembly (2). Then, disconnect the instrument panel connector (3) and emergency lamp connector (4).

SAFETY FIRST

GENERAL

ENGINE

CVT

TRANSMISSION

CHASSIS

REAR AXLE

BRAKE

FRONT AXLE

STEERING

HYDRAULIC

ELECTRIC

INDEX

SAFETY FIRST

GENERAL

ENGINE

CVT

TRANSMISSION

CHASSIS

REAR AXLE

BRAKE

FRONT AXLE

STEERING

HYDRAULIC

ELECTRIC

INDEX



4. Remove the main instrument panel (1).

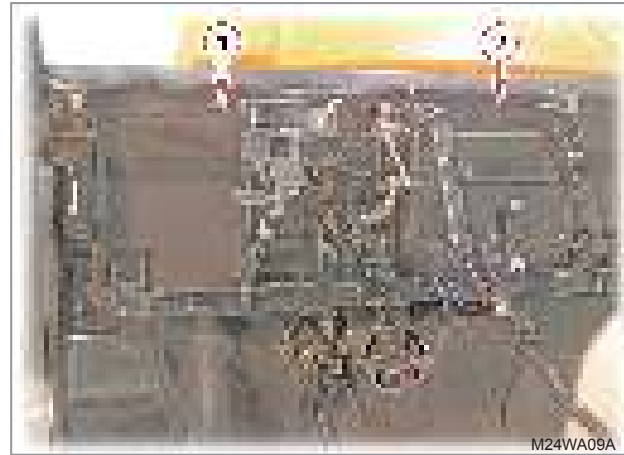

5. Disconnect the wiring (1) and remove the parking brake lever (2).



6. Unscrew the frame mounting bolt (1) to remove the frame assembly (2).

REMARK



- Remove the steering cover assembly (3) if necessary.



7. Remove the brake pedal assembly (1).



10. Unscrew the mounting nuts (1) of the tie rod ends (LH, RH) to remove the tie rod (2).



8. Unscrew the screw (1) to remove the main floor assembly (2).

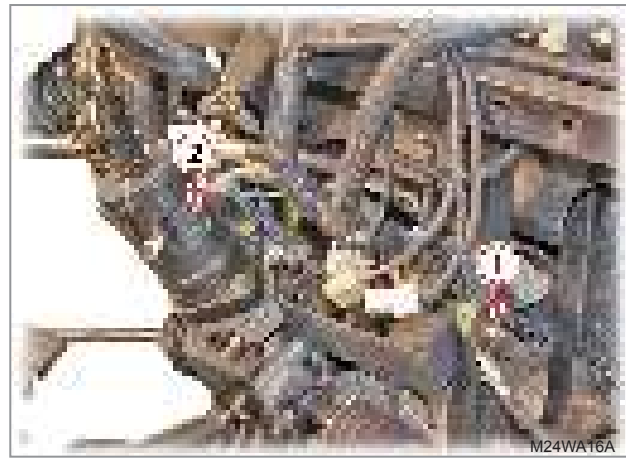

11. Unscrew the steering gearbox bracket mounting bolt (1) to remove the gearbox assembly (2).



9. Disconnect the torque generator hydraulic hose (1).

**Hydraulic hose
tightening torque 49 Nm
5 kgf-m
36 lb-ft**

SAFETY FIRST
GENERAL
ENGINE
CVT
TRANSMISSION
CHASSIS
REAR AXLE
BRAKE
FRONT AXLE
STEERING
HYDRAULIC
ELECTRIC
INDEX

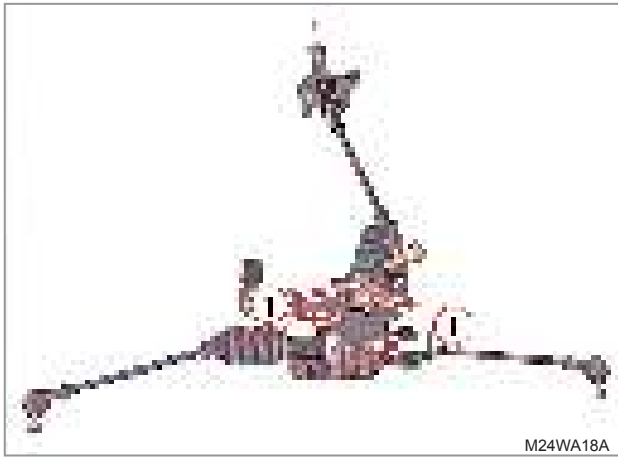

M24WA18A

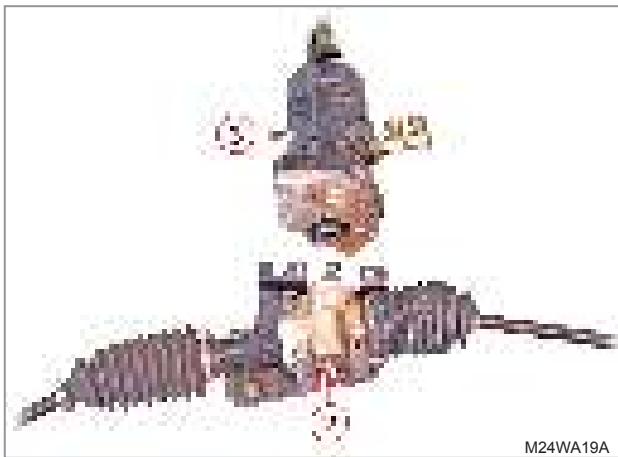

M24WA19A

12. Unscrew the bracket mounting bolts (1) to remove the steering gearbox (2) and torque generator (3).

! IMPORTANT

- When installing the steering gear box mounting bolt and bracket mounting bolt, apply **LOCTITE #242** or equivalent to its threads and tighten it to the specified.

Tightening torque **25.0 Nm**
2.55 kgf-m
18.37 lb-ft



UUVW906A

13. Undo the band (1) and remove the rubber boot bellows (2).

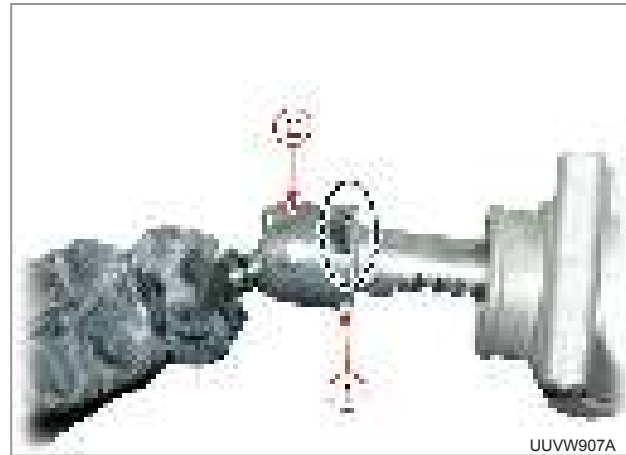

UUVW907A

14. Unfold the caulked part of the holder (1) and rotate the ball joint (2) to separate the left and right ball joint assemblies from the steering gearbox.

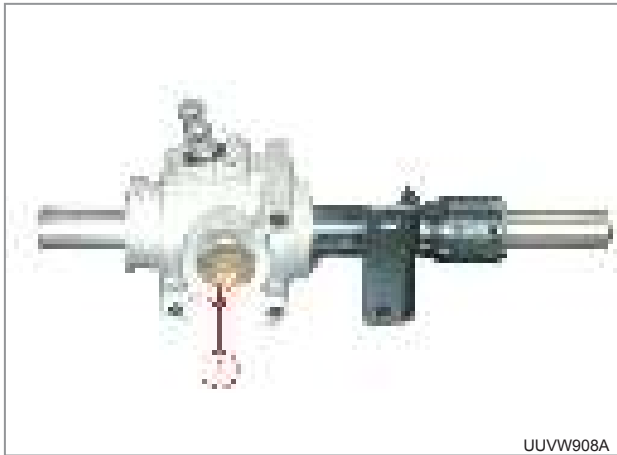

UUVW908A



UUVW909A

15. Unscrew the hexagon bolt (1) on the bottom using the 17 mm hex. wrench and remove the spring (2) and shaft guide (3).



UUVW910A

16. Remove the cap (1) and pull out the pinion shaft (2).



UUVW911A

17. Remove the rack (1) by pulling it to the side.



UUVW912A

18. Assemble in the reverse order of disassembly.

REMARK

- When removing the cap, be careful not to damage the oil seal. If a new oil seal is to be fitted, apply grease to its mating surface.
- During assembly, apply grease to the engaging sections of the gears and in the case sufficiently.

TORQUE GENERATOR COMPONENTS DISASSEMBLY



1. Remove the bearing holder (1: M8 bolt, 3 EA) and middle case (2: M10 bolt, 2 EA).

M8 bolt
tightening torque 17.6 ~ 20.6 Nm
1.8 ~ 2.1 kgf-m
13.0 ~ 15.1 lb-ft

M10 bolt
tightening torque 39.2 ~ 44.1 Nm
4.0 ~ 4.5 kgf-m
28.8 ~ 32.4 lb-ft

2. Pull out the snap ring (1) and remove the bearing (2) and shaft (3).



UT3WAB6A

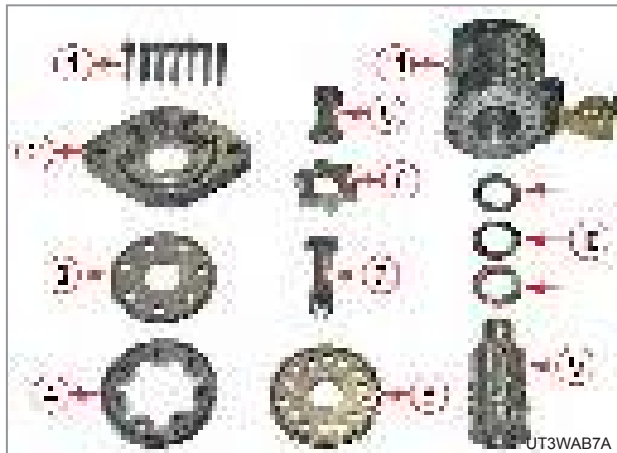

UT3WAB7A

3. Unscrew the hexagonal wrench bolts (1: M8 - 7 EA) and remove the end cap (2), spacer (3), Gerotor (4), drive shaft 1 (5), rotor (6), drive shaft 2 (7), spacer (8), spool (sleeve) assembly (9) and bearing (10) from the housing (11).

SAFETY FIRST
GENERAL
ENGINE
CVT
TRANSMISSION
CHASSIS
REAR AXLE
BRAKE
FRONT AXLE
STEERING
HYDRAULIC
ELECTRIC
INDEX

SAFETY FIRST

GENERAL

ENGINE

CVT

TRANSMISSION

CHASSIS

REAR AXLE

BRAKE

FRONT AXLE

STEERING

HYDRAULIC

ELECTRIC

INDEX

6. COMPONENTS AND JOB CODES

6.1 G220002 STEERING GROUP (USA)

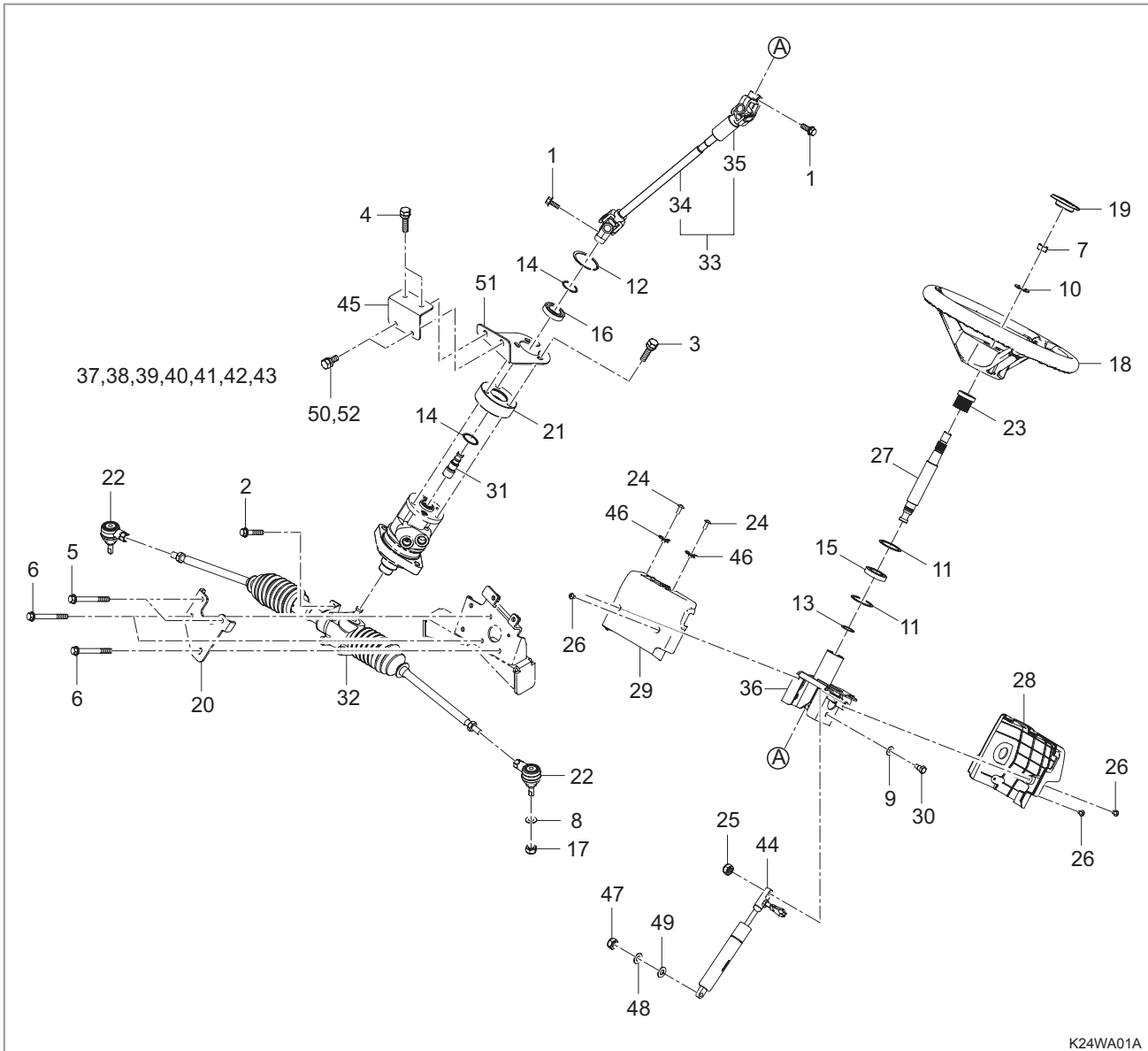

K24WA01A

COMPONENTS AND JOB CODES

- | | | |
|-------------------------------|---|---|
| (1) Bolt, Washer | (19) Cap, handle (W020002) | (37) Cobi Mounting Bracket |
| (2) Bolt, Washer | (20) Steering Brkt, front (W020003) | (38) Aircylinder Bracket, Handle |
| (3) Bolt, Washer | (21) Bearing Holder (W020004) | (39) Steering Shaft Pipe |
| (4) Bolt | (22) Tie Rod End Assy (W020005) | (40) Colume Mount Bracket, UPR |
| (5) Bolt | (23) Cushion, Rubber | (41) Column Mount Bracket, LWR |
| (6) Bolt | (24) Screw (Black) | (42) Steering Bracket Sub Assy |
| (7) Nut | (25) Lock Nut | (43) Tilt Shaft |
| (8) Washer, Plain | (26) Screw_meter Cluster (Tapping, Black) | (44) Air Cylinder Assy, Tilting (W020012) |
| (9) Plain_washer | (27) Steering Shaft Wheel (W020006) | (45) Bearing Holder Mount Assy (W020013) |
| (10) Spring_washer | (28) Steering Cover, LWR (W020007) | (46) Speed Nut (M6) |
| (11) Snap Ring | (29) Steering Cover, UPR | (47) Lock Nut |
| (12) Ring, Stopper | (30) Bolt | (48) Washer |
| (13) Snap Ring | (31) Steering Shaft (W020008) | (49) Washer |
| (14) Snap Ring | (32) Gear box ass'y (W020009) | (50) Flange Bolt |
| (15) Ball Bearing | (33) Colume, Universal Joint (W020010) | (51) Brkt, Holder Bearing (W020014) |
| (16) Ball Bearing | (34) Universal Shaft Assy, LWR | (52) Flange Bolt |
| (17) U-nut | (35) Universal Joint, up | |
| (18) Steering Wheel (W020001) | (36) Steering BRKT Assy (W020011) | |

6.2 G531002 POWER STEERING UNIT GROUP

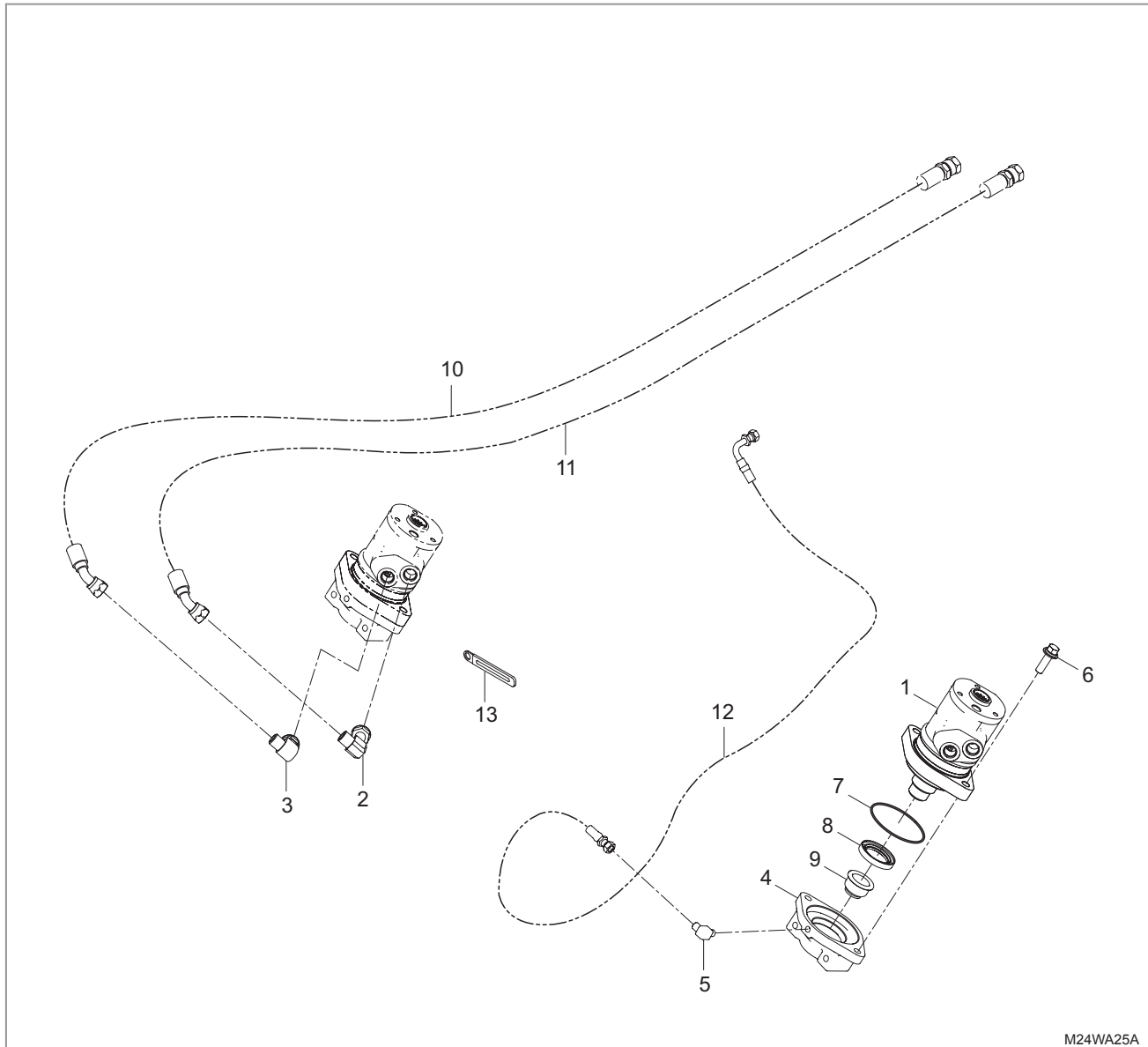

M24WA25A

COMPONENTS AND JOB CODES

- | | |
|---|------------------------------------|
| (1) Torque Generator (N050001, N050002) | (8) Seal, Oil (N050005) |
| (2) Elbow (N050003) | (9) Power End Shaft Boot (N050006) |
| (3) Elbow (N050003) | (10) Assy Hose, HYD-P2 (N050007) |
| (4) Case, middle (N050004) | (11) Assy Hose, HYD-C2 (N050008) |
| (5) Elbow | (12) Assy Hose, HYD-T (N050009) |
| (6) Bolt | (13) Clamp, cord |
| (7) O Ring | |

SAFETY FIRST
GENERAL
ENGINE
CVT
TRANSMISSION
CHASSIS
REAR AXLE
BRAKE
FRONT AXLE
STEERING
HYDRAULIC
ELECTRIC
INDEX

MEMO

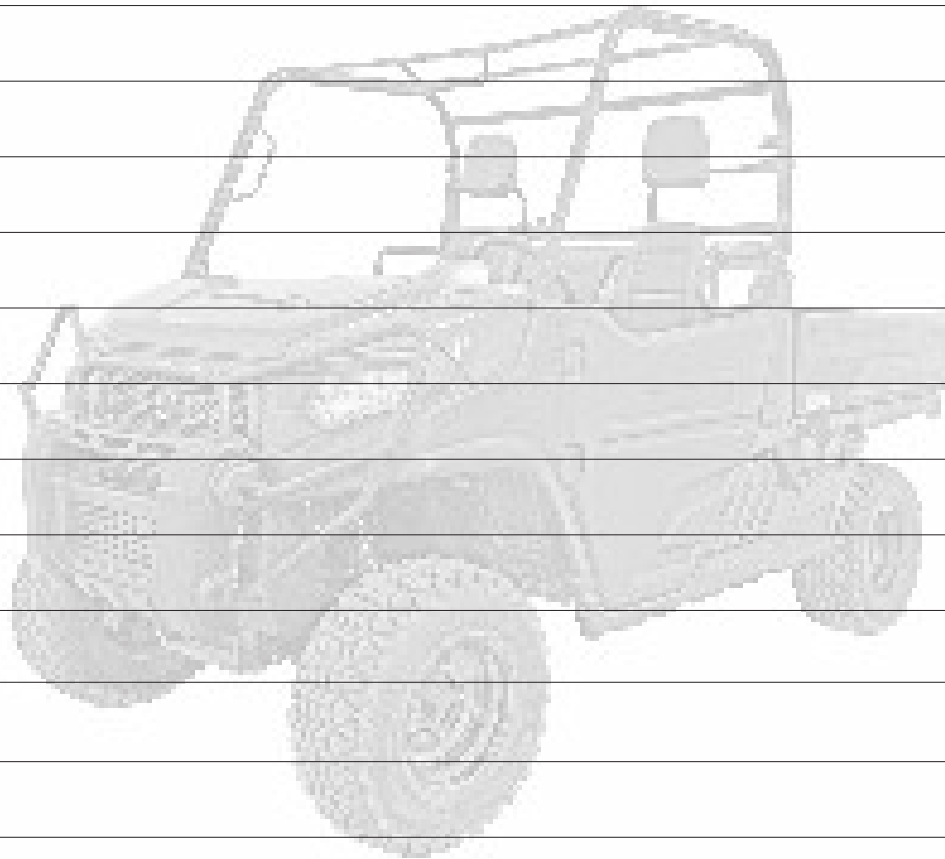



**K9 2400
K9 2440**

HYDRAULIC SYSTEM

CHAPTER 11

TABLE OF CONTENTS

1. SPECIFICATIONS	11-2		
2. OPERATING PRINCIPLE	11-3		
2.1 Hydraulic component layout	11-3		
2.2 Hydraulic circuit	11-5		
2.3 Hydraulic line	11-6		
2.3.1 Dumping operation.....	11-6		
2.3.2 External hydraulic oil operation (Optional)	11-8		
2.4 Gear pump.....	11-10		
2.5 Dumping cylinder (AU:STD, US/EU:OPT).....	11-12		
2.6 Control valve assembly.....	11-14		
2.7 Auxiliary hydraulic valve (Optional)....	11-16		
3. TROUBLESHOOTING	11-18		
4. INSPECTION AND ADJUSTMENT	11-19		
4.1 Main relief valve pressure.....	11-19		
4.2 External hydraulic pressure	11-20		
5. DISASSEMBLY, SERVICE AND ASSEMBLY ...	11-20		
5.1 Gear pump disassembly and assembly ...	11-20		
5.1.1 Gear pump removal	11-20		
5.1.2 Gear pump disassembly	11-21		
5.2 Auxiliary hydraulic valve, dumping valve and front block (relief valve) disassembly and assembly (Optional) ..	11-22		
5.2.1 Valve removal	11-22		
5.2.2 Auxiliary hydraulic valve disassembly	11-24		
5.2.3 Dumping valve disassembly (AU:STD, US/EU:OPT.)	11-27		
5.2.4 Front block (relief valve) disassembly	11-28		
5.3 Dumping cylinder disassembly and assembly (AU:STD, US/EU:OPT.).....	11-29		
5.3.1 Dumping cylinder removal	11-29		
5.3.2 Dumping cylinder disassembly	11-30		
6. EXPLODED VIEW	11-31		
6.1 G513002 Gear pump group	11-31		
6.2 G551004 Control valve group	11-32		
6.3 G591002 Dump cylinder group.....	11-33		
6.4 G511002 Oil tank group	11-34		

1. SPECIFICATIONS

Item	Specifications	Remarks
Operating oil	Daedong UTF55 Exxon Mobilfluid 423 or 424 BP Tractran UTH Shell DONAX-TD	
Oil tank capacity	15.0 ℓ (3.96 u.s.gal.)	
Gear pump capacity	24.1 ℓ/min (6.36 u.s.gal./min)	
Gear pump discharge flow	10 cc/rev	
Maximum pressure	210 kgf/cm ² (20.58 MPa, 2,986 psi)	
Rotating direction	Counterclockwise	
Dumping cylinder	Single rod, double acting type Cylinder outside diameter Ø 60 mm (2.362 in.) Cylinder inside diameter Ø 50 mm (1.969 in.) Rod outside diameter Ø 25 mm (0.984 in.) Stroke 212.5 mm (8.366 in.) Front block port PF3/8 Nipple PF1/4	
Relief valve pressure	<ul style="list-style-type: none"> • 105 ⁺⁵₀ kgf/cm² • 10.29 ^{+0.049}₀ MPa • 1,493 ⁺⁷¹₀ psi 	
External hydraulic port specification	1 valve (2 ports: flat face, self-sealing, 1-1/4)	
Dumping valve	Port PF3/8	
Valve mounting bolt tightening torque	24.5 ~ 27.4 Nm 2.5 ~ 2.8 kgf-m 18.0 ~ 20.2 lb-ft	
Torque generator capacity	• 76 cc/rev	
Torque generator relief setting pressure	• 50 ⁺⁵ ₀ kgf/cm ² / 4.9 ^{+0.049} ₀ MPa / 711 ⁺⁷¹ ₀ psi	
Torque generator type	• Open center non-load reaction	

SAFETY FIRST

GENERAL

ENGINE

CVT

TRANSMISSION

CHASSIS

REAR AXLE

BRAKE

FRONT AXLE

STEERING

HYDRAULIC

ELECTRIC

INDEX

2. OPERATING PRINCIPLE

2.1 HYDRAULIC COMPONENT LAYOUT

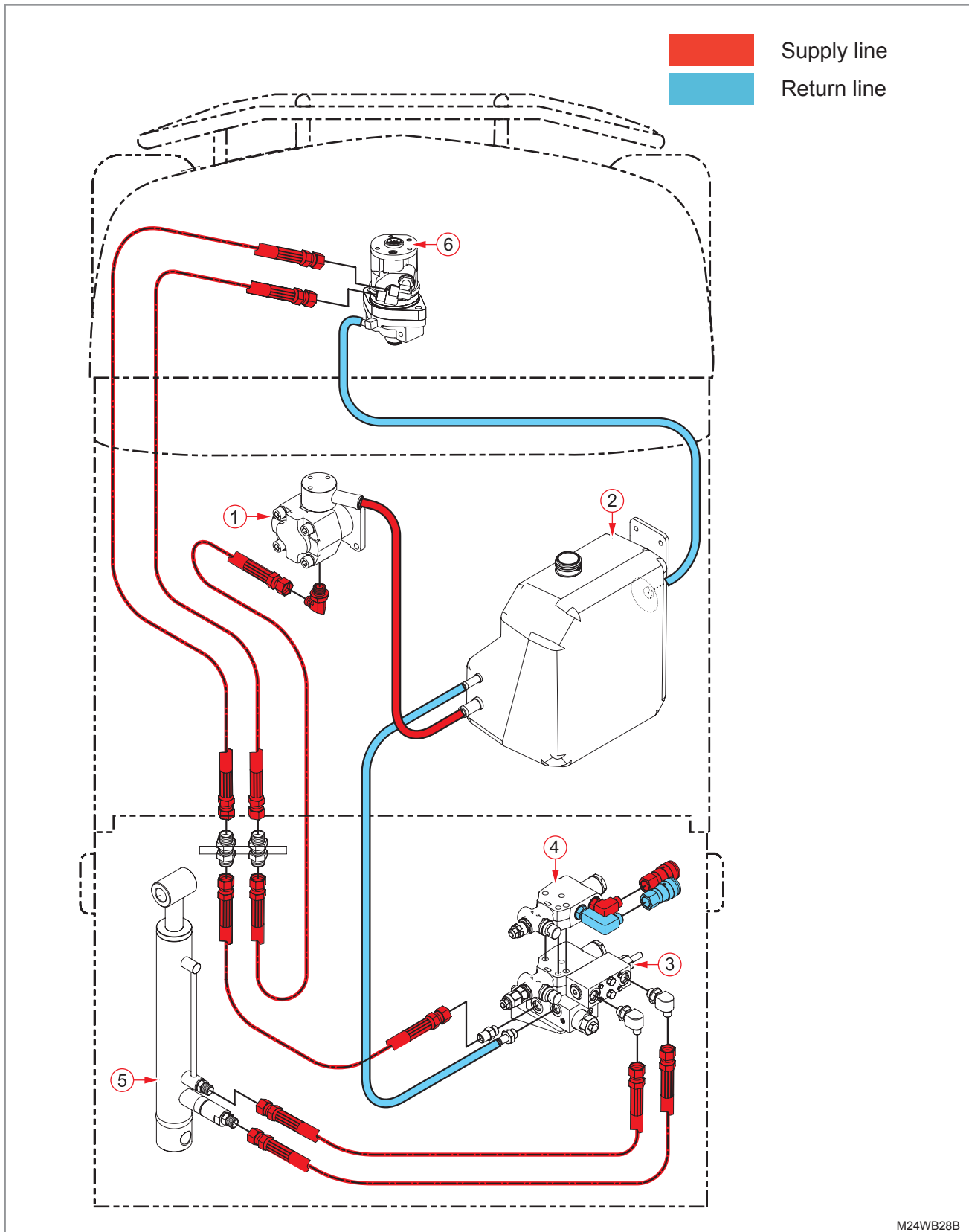

(1) Gear pump
(2) Oil tank

(3) Dumping valve (AU)
(4) Auxiliary hydraulic valve

(5) Dumping cylinder (AU)
(6) Torque generator

SAFETY FIRST
GENERAL
ENGINE
CVT
TRANSMISSION
CHASSIS
REAR AXLE
BRAKE
FRONT AXLE
STEERING
HYDRAULIC
ELECTRIC
INDEX

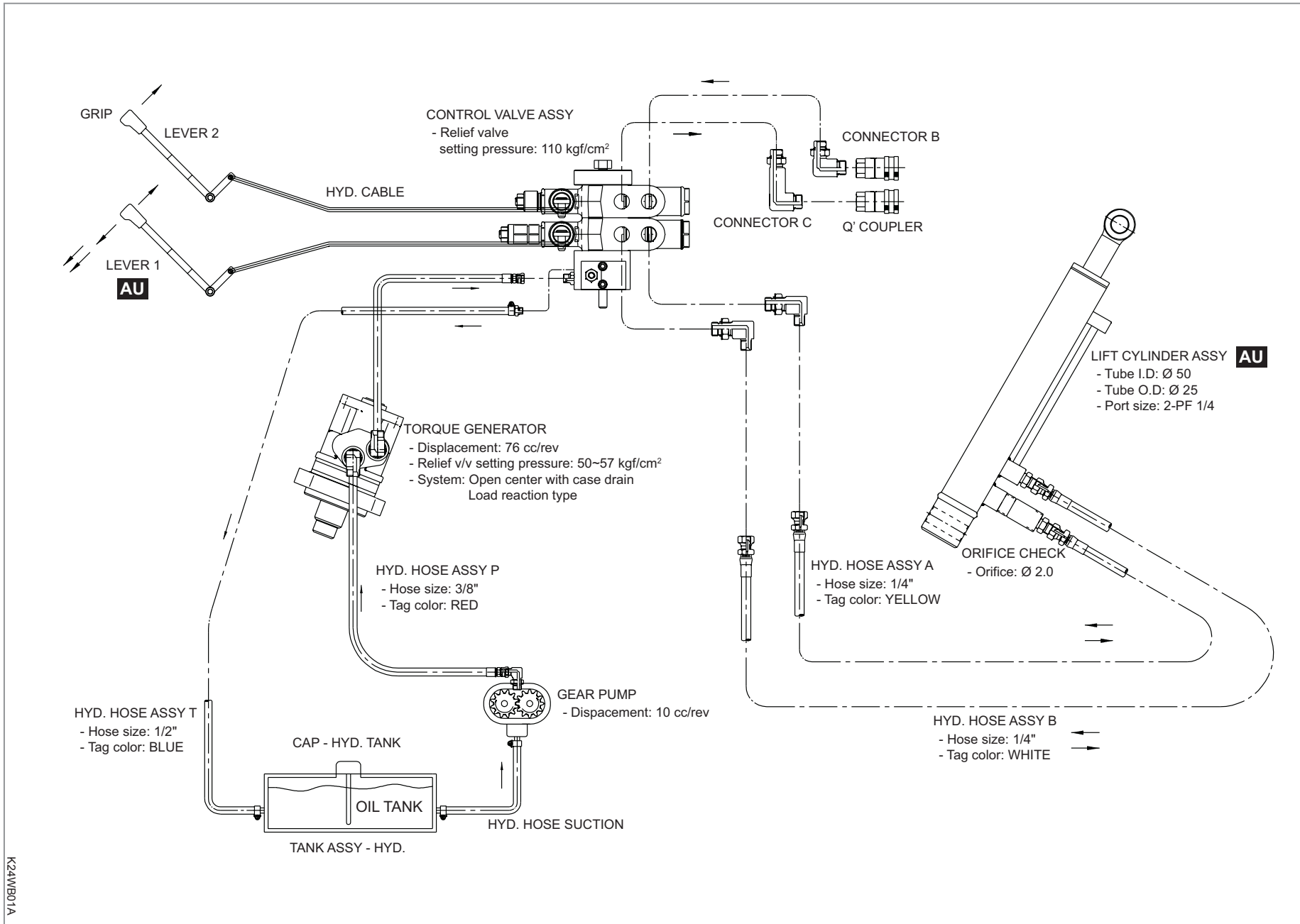

K24WB01A



2.2 HYDRAULIC CIRCUIT

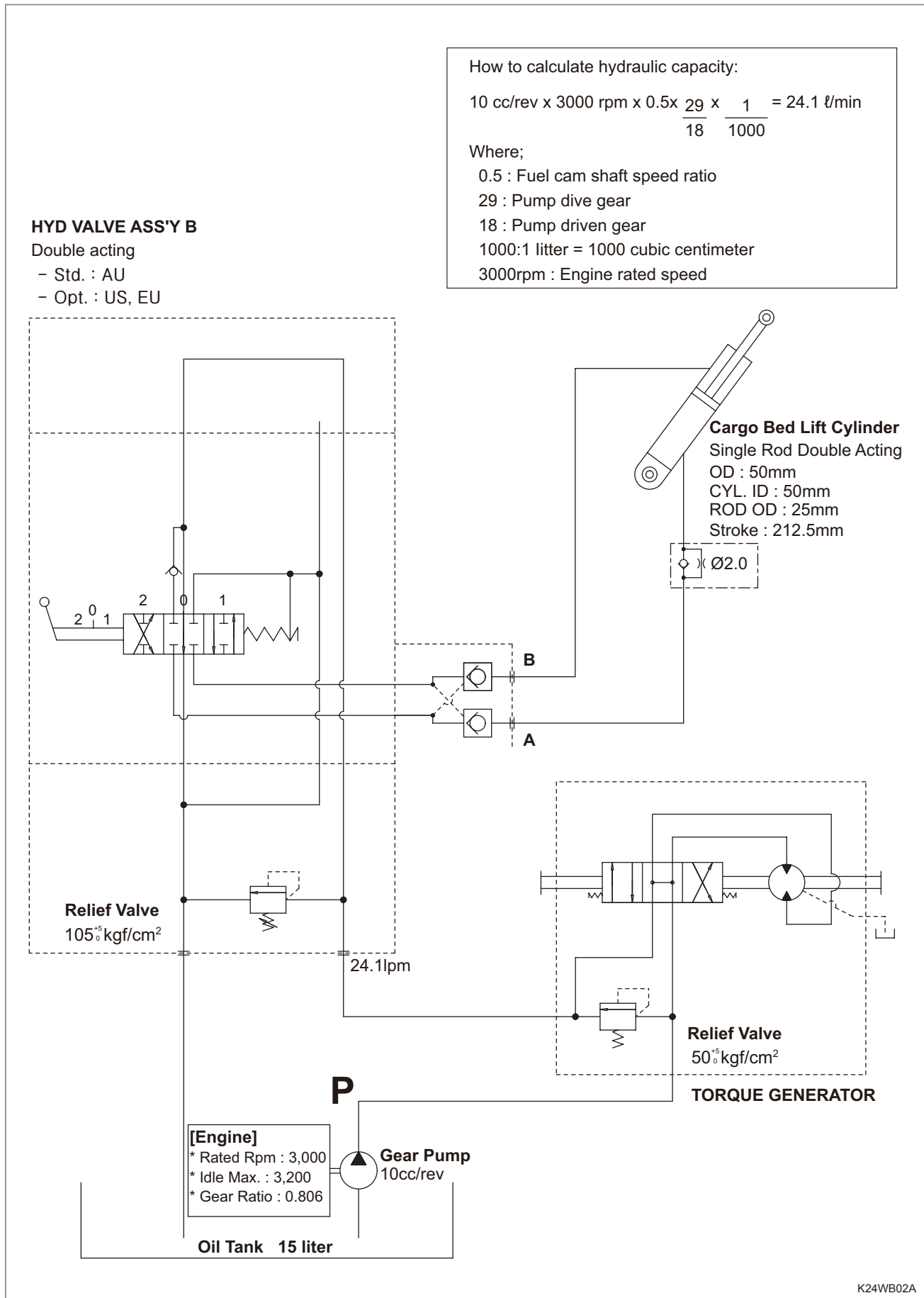

SAFETY FIRST
GENERAL
ENGINE
CVT
TRANSMISSION
CHASSIS
REAR AXLE
BRAKE
FRONT AXLE
STEERING
HYDRAULIC
ELECTRIC
INDEX

SAFETY FIRST

GENERAL

ENGINE

CVT

TRANSMISSION

CHASSIS

REAR AXLE

BRAKE

FRONT AXLE

STEERING

HYDRAULIC

ELECTRIC

INDEX

2.3 HYDRAULIC LINE

2.3.1 DUMPING OPERATION

HYDRAULIC OIL FLOW DIAGRAM

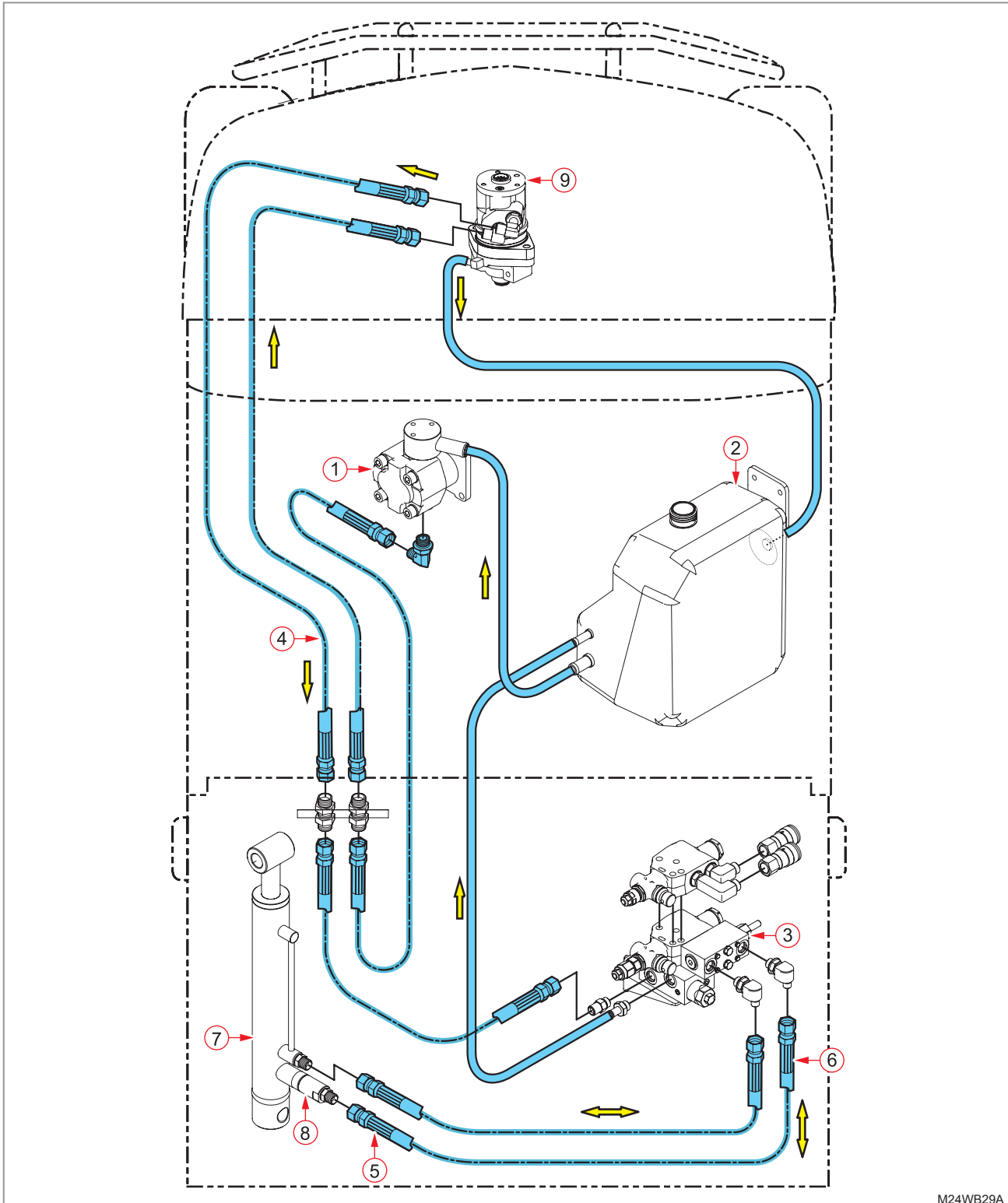

M24WB29A

- | | | |
|------------------------------|--|---------------------------|
| (1) Gear pump | (4) Hydraulic hose p | (7) Dumping cylinder |
| (2) Oil tank | (5) Hydraulic hose B (with white tag) | (8) Orifice & check valve |
| (3) Dumping valve (for dump) | (6) Hydraulic hose A (with yellow tag) | (9) Torque generator |

- For the power steering model, hydraulic oil flowing toward the dumping valve by the gear pump is led to the torque generator (9) first to be used for steering. Then, it is carried to the front block under the dumping valve. The setting pressure of the relief valve in the front block of the hydraulic circuit is 105 kgf/cm² for the power steering model.

2.3.2 EXTERNAL HYDRAULIC OIL OPERATION (OPTIONAL)

HYDRAULIC OIL FLOW DIAGRAM

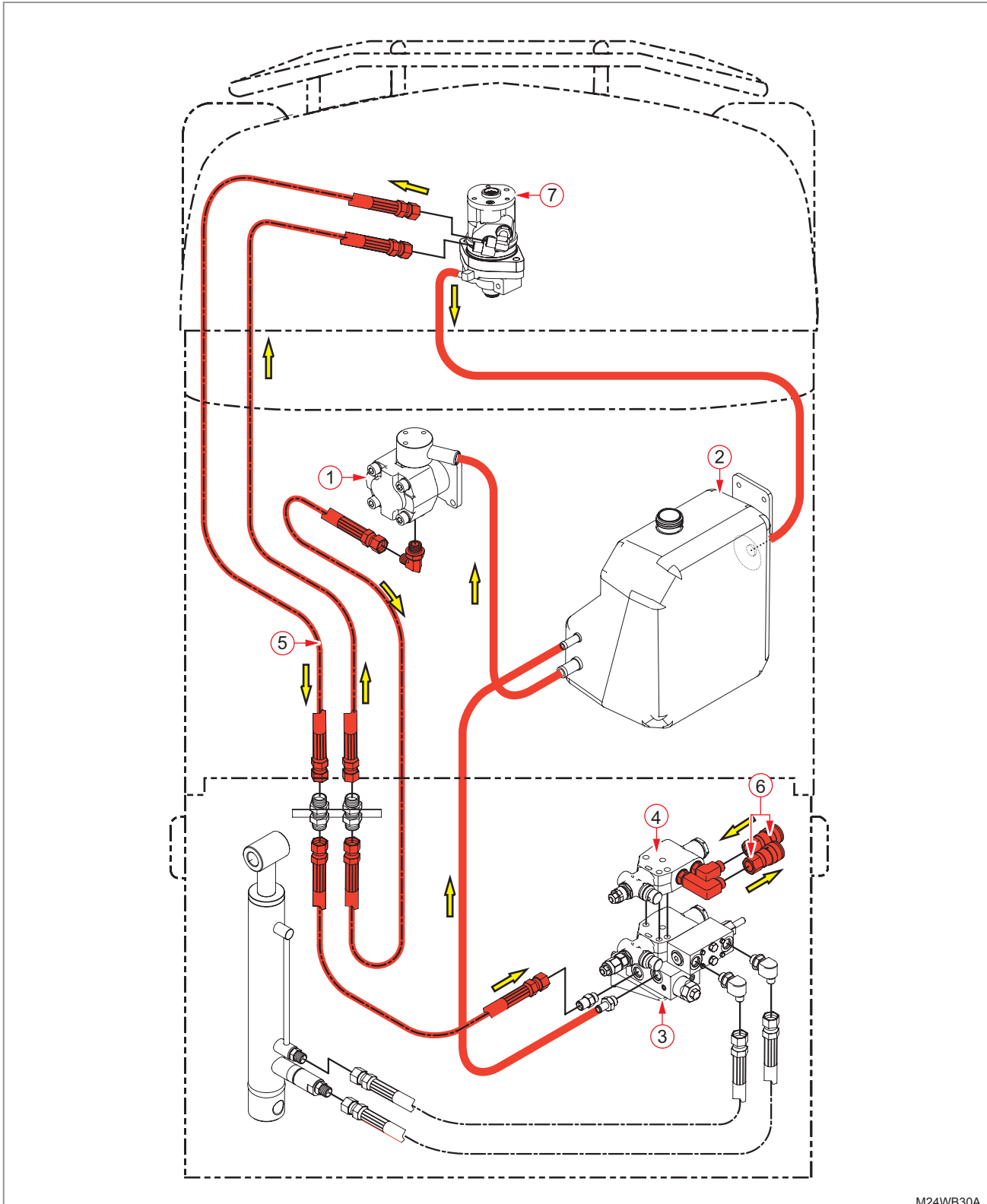

M24WB30A

- | | | | |
|---------------|----------------------------|----------------------------|----------------------|
| (1) Gear pump | (3) Control valve assembly | (5) Hydraulic hose P | (7) Torque generator |
| (2) Oil tank | (4) Remote hydraulic valve | (6) Quick coupler (parker) | |

- Hydraulic oil is supplied to the control valve assembly from the gear pump (1) after it passes through the torque generator (7). After the external hydraulic implement is operated by this hydraulic oil through the remote hydraulic valve, it is returned to the oil tank, forming one cycle.

CIRCUIT

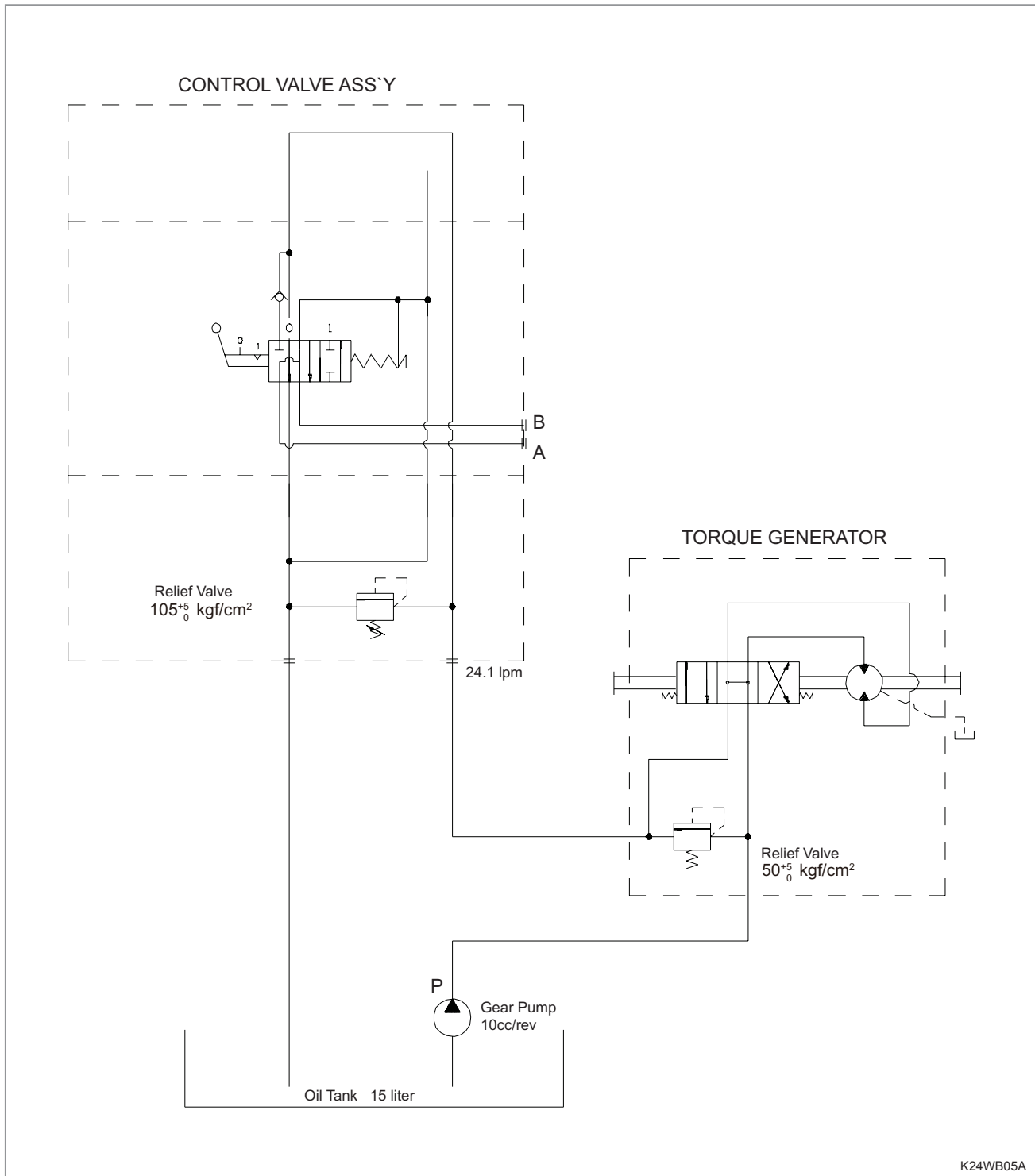

SAFETY FIRST
GENERAL
ENGINE
CVT
TRANSMISSION
CHASSIS
REAR AXLE
BRAKE
FRONT AXLE
STEERING
HYDRAULIC
ELECTRIC
INDEX

SAFETY FIRST

GENERAL

ENGINE

CVT

TRANSMISSION

CHASSIS

REAR AXLE

BRAKE

FRONT AXLE

STEERING

HYDRAULIC

ELECTRIC

INDEX

2.4 GEAR PUMP

MOUNTING LOCATION AND STRUCTURE

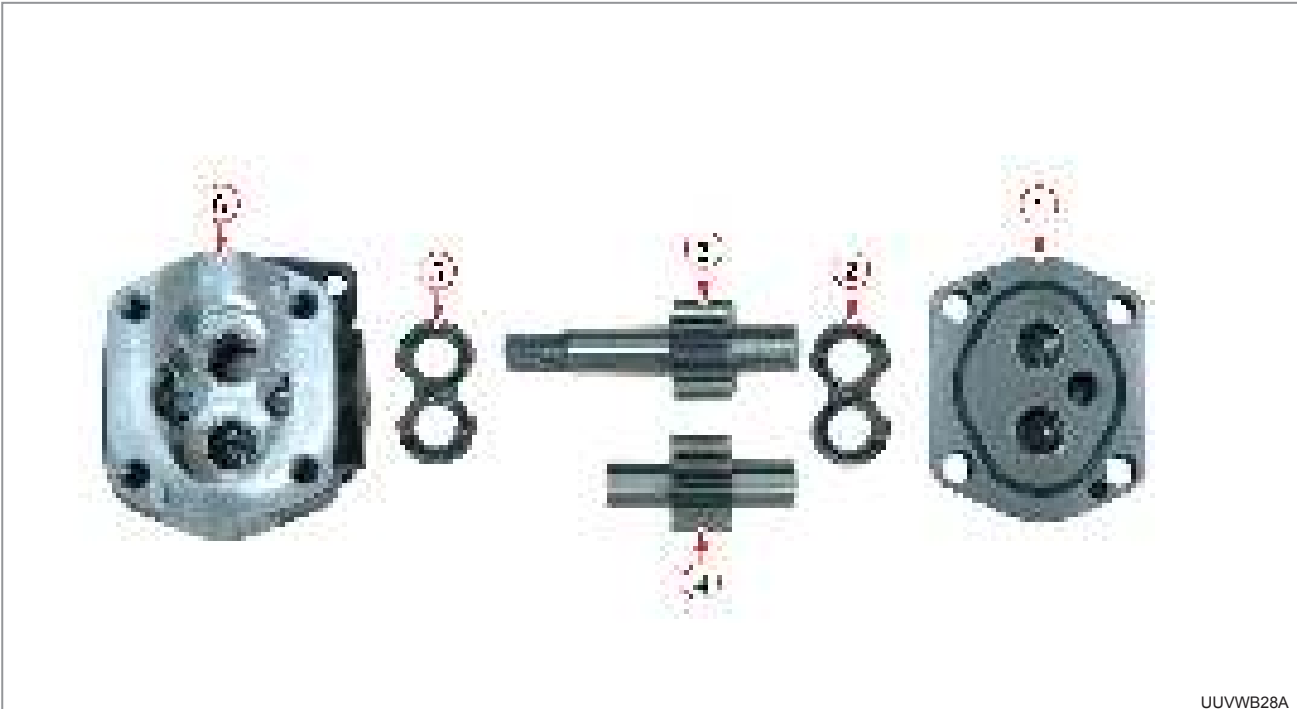
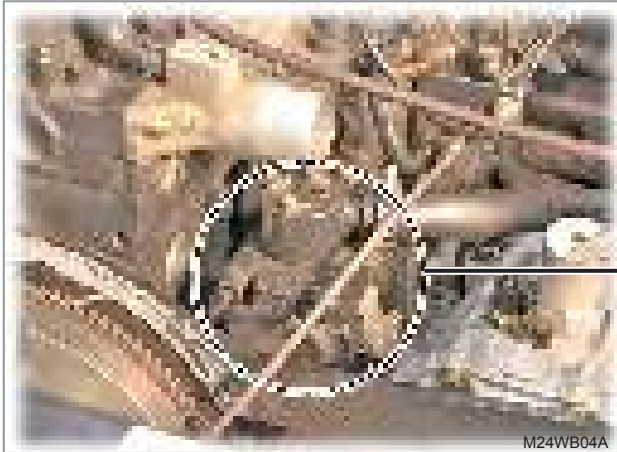

(1) REAR COVER
(2) SEAL BLOCK

(3) DRIVE GEAR SHAFT
(4) DRIVEN GEAR

(5) SEAL BLOCK
(6) CASE

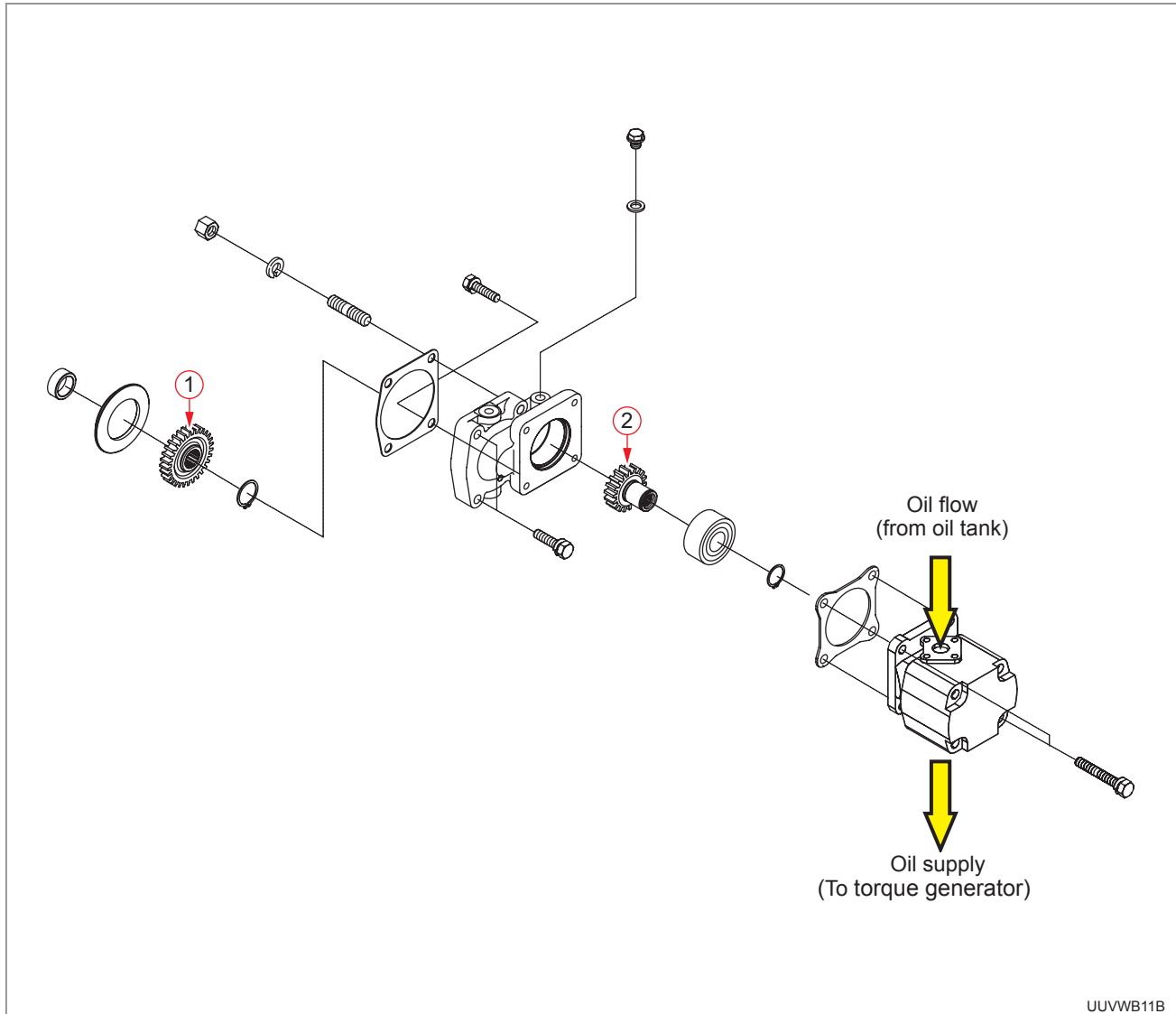

- The hydraulic pump is driven by the fuel camshaft in the engine. The fuel camshaft rotates at half speed of the engine. However, the rotating speed is increased by the 29 gear (1) and 18 gear (2) to drive the hydraulic pump.

Engine 3000rpm

Engine and gear pump speed ratio 1: 0.805

$3000 \times 1/2 \times 29/18 = 2417 \text{ rpm}$

- The hydraulic pump is always driven as long as the engine is running to draw the oil from the oil tank through its top and supply it to the torque generator through its bottom port.

SAFETY FIRST
GENERAL
ENGINE
CVT
TRANSMISSION
CHASSIS
REAR AXLE
BRAKE
FRONT AXLE
STEERING
HYDRAULIC
ELECTRIC
INDEX

SAFETY FIRST

GENERAL

ENGINE

CVT

TRANSMISSION

CHASSIS

REAR AXLE

BRAKE

FRONT AXLE

STEERING

HYDRAULIC

ELECTRIC

INDEX

2.5 DUMPING CYLINDER (AU:STD, US/EU:OPT)

MOUNTING LOCATION AND STRUCTURE

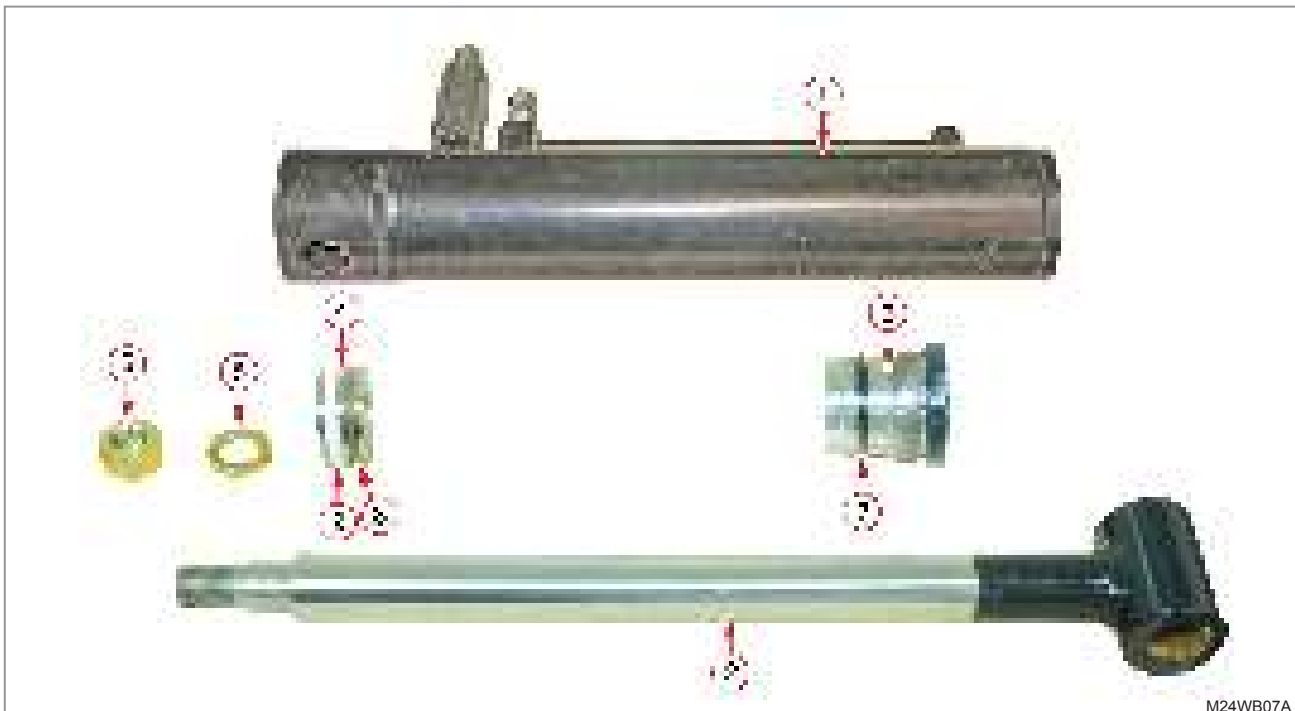

- | | | |
|----------------|-------------------|--------------------|
| (1) Tube | (4) Piston | (7) O ring |
| (2) Rod | (5) Spring washer | (8) Piston packing |
| (3) Head cover | (6) Nut | (9) Wear ring |

The dumping cylinder is a double acting single-rod cylinder. Its rod outside diameter is 25mm (0.984 in.), its inside diameter is 50mm (1.97 in.), its outside diameter is 60mm (2.36 in.) and its stroke is 212.5mm (8.37 in.).

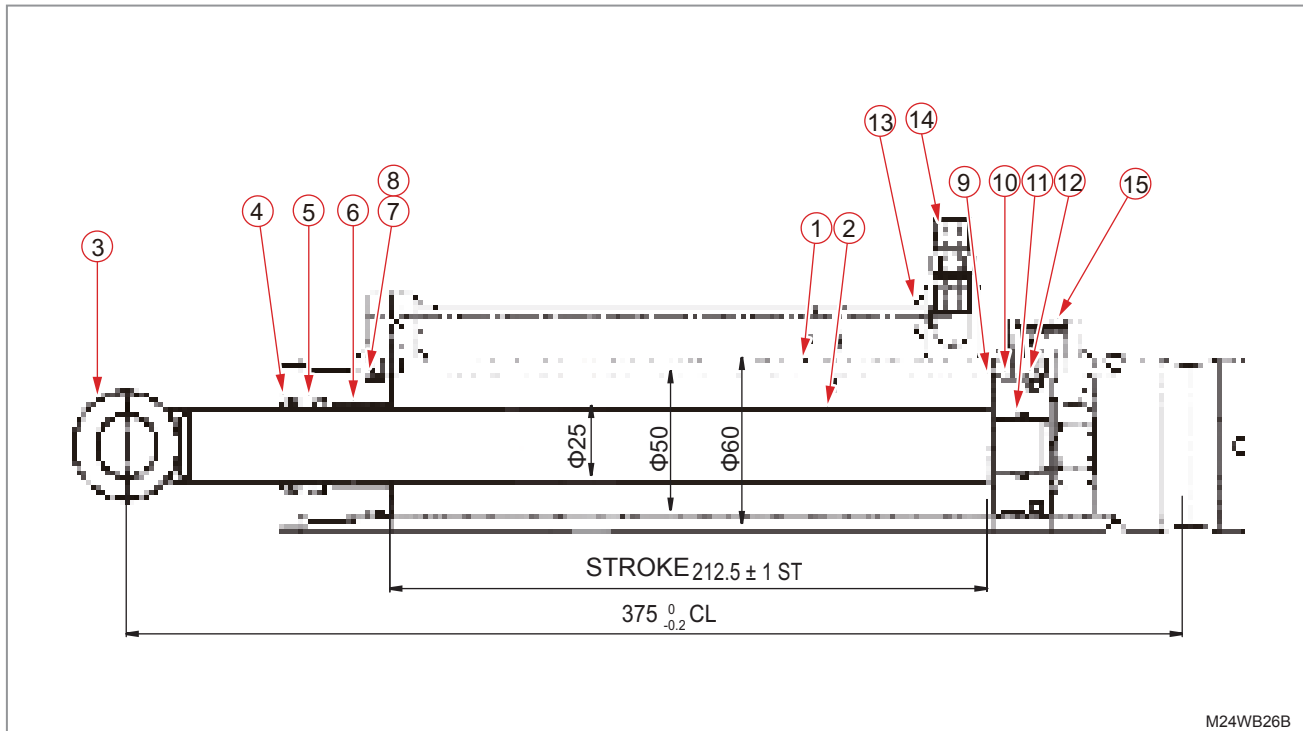

- | | | | |
|---------------|---------------|------------------|------------------------|
| (1) Tube | (5) Rod seal | (9) Piston | (13) PT 1/4 socket (S) |
| (2) Rod | (6) DU bush | (10) Wear ring | (14) Nipple |
| (3) Rod end | (7) O-ring | (11) O-ring | (15) PF 3/8 socket |
| (4) Dust seal | (8) Back ring | (12) Piston seal | |

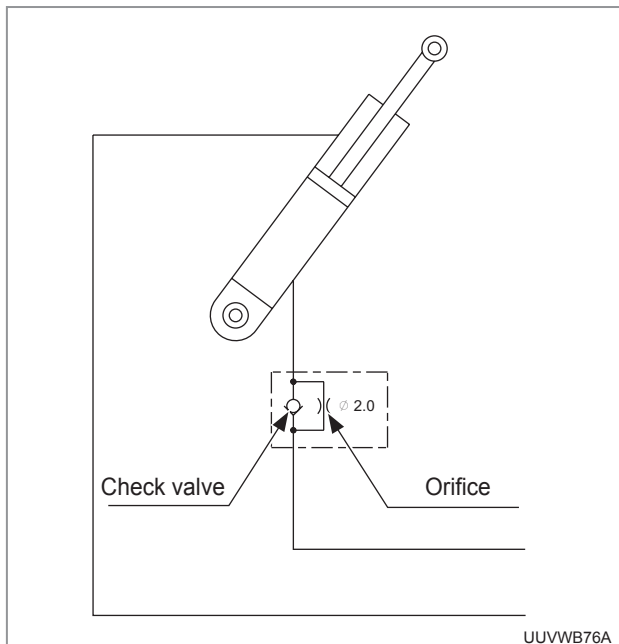

The hydraulic line on the lifting side of the dumping cylinder is equipped with the orifice and check valve. When the cylinder is extended (lifting), the check valve is opened to draw more oil into the cylinder. On the other hand, when the cylinder is retracted (lowering), the check valve is closed and the discharged oil passes through the orifice to slow the flow in order to slow down the lowering speed of the cargo bed.

SAFETY FIRST

GENERAL

ENGINE

CVT

TRANSMISSION

CHASSIS

REAR AXLE

BRAKE

FRONT AXLE

STEERING

HYDRAULIC

ELECTRIC

INDEX

2.6 CONTROL VALVE ASSEMBLY

MOUNTING LOCATION AND STRUCTURE



M24WB14A

FRONT BLOCK (RELIEF VALVE)

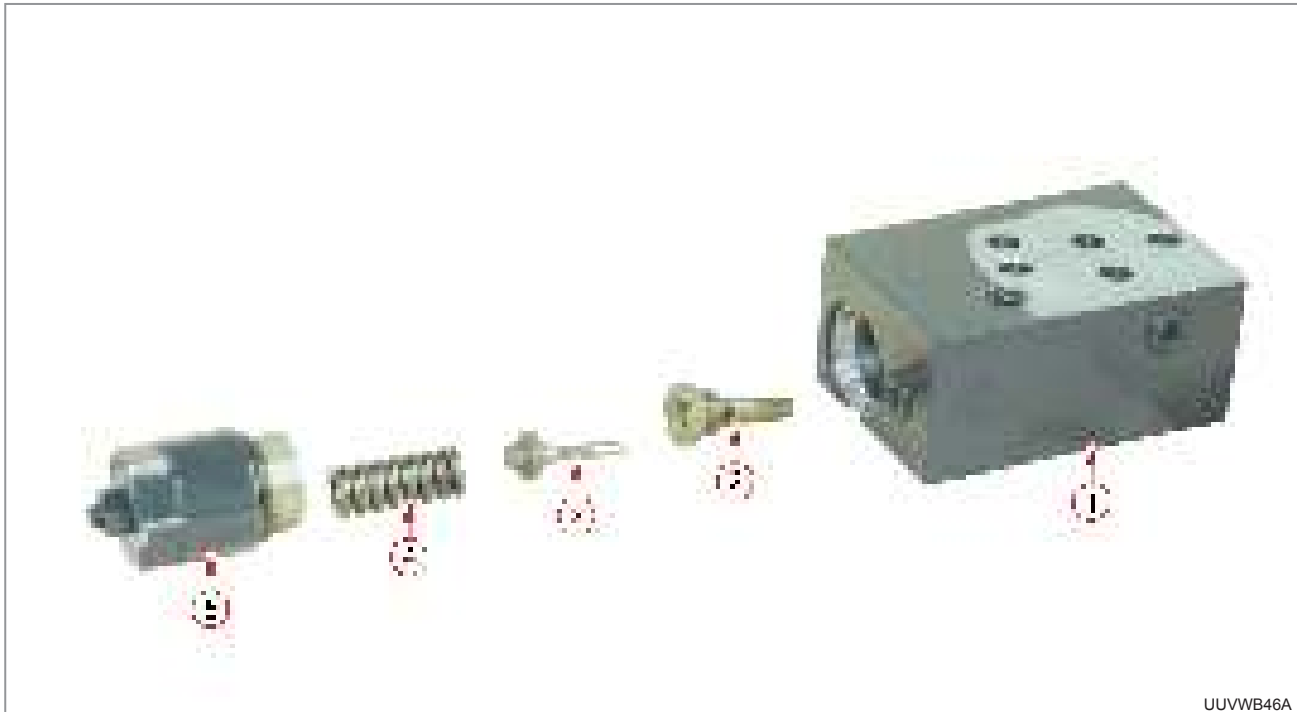

UUVWB46A

- (1) Body
- (2) Spool
- (3) Poppet
- (4) Spring
- (5) Cover

A relief valve is integrated in the front block and its setting pressure is 105^{+5}_0 kgf/cm². Therefore, when the internal pressure is over the setting pressure due to overload for the external implement or dump, the relief valve is open to protect the hydraulic system.

DUMPING VALVE (AU)

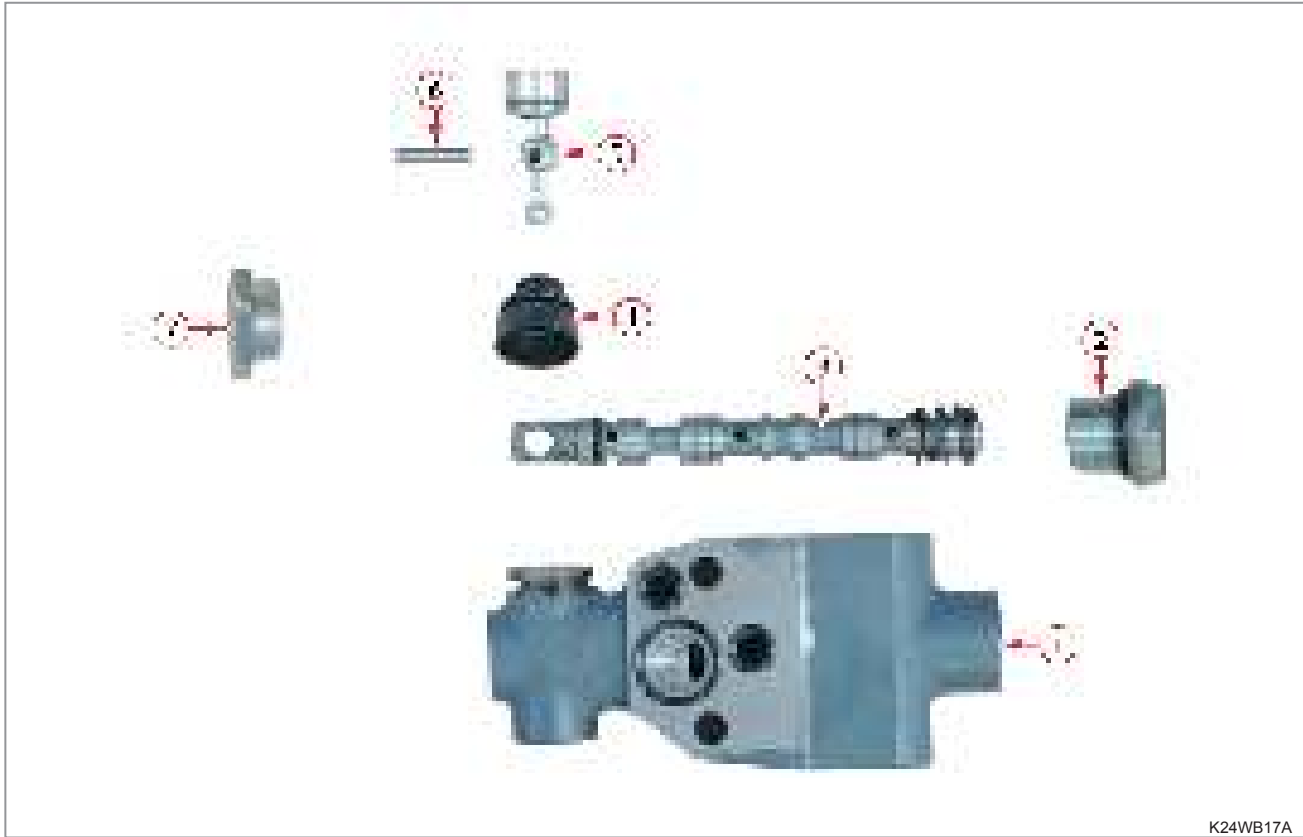

K24WB17A

- (1) Body
- (2) Plug
- (3) Spool Assembly
- (4) Bellows
- (5) Lever
- (6) Pin
- (7) Plug

SIDE BLOCK

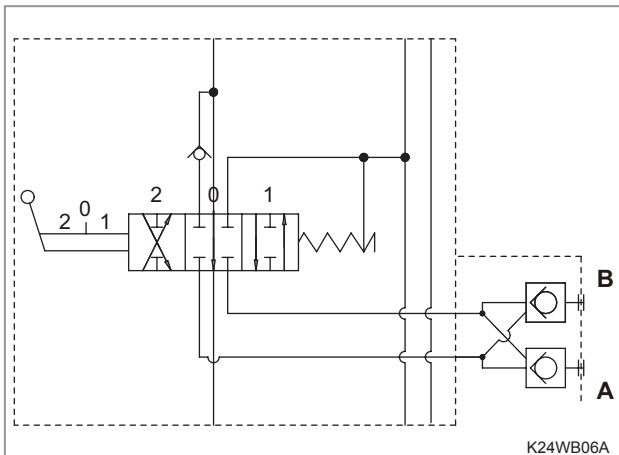

K24WB06A



UT3WBA4A

The dumping valve is a double acting type. When the valve lever is operated to the cylinder extending direction, the cargo bed is lifted. Operating the valve lever to the cylinder retracting direction lowers the cargo bed.

SAFETY FIRST
GENERAL
ENGINE
CVT
TRANSMISSION
CHASSIS
REAR AXLE
BRAKE
FRONT AXLE
STEERING
HYDRAULIC
ELECTRIC
INDEX

SAFETY FIRST

GENERAL

ENGINE

CVT

TRANSMISSION

CHASSIS

REAR AXLE

BRAKE

FRONT AXLE

STEERING

HYDRAULIC

ELECTRIC

INDEX

2.7 AUXILIARY HYDRAULIC VALVE (OPTIONAL)

MOUNTING LOCATION AND STRUCTURE

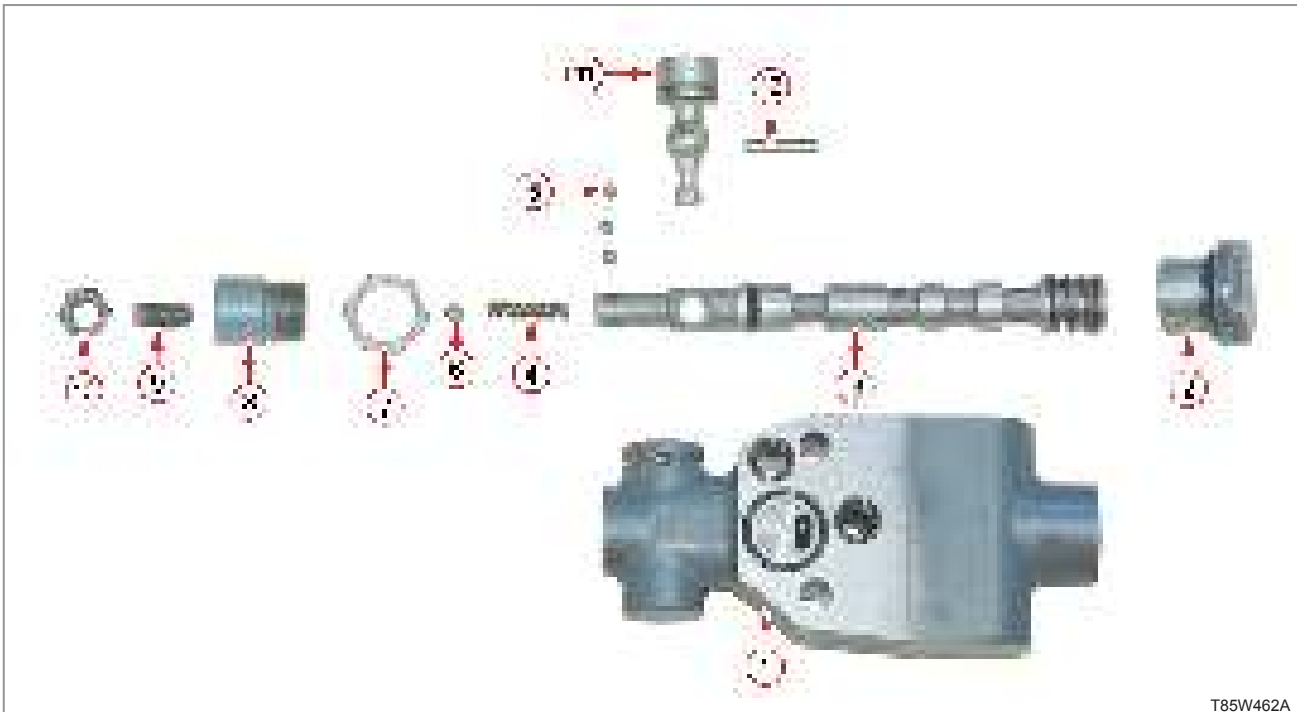

- | | | |
|--------------------|--------------------|------------------|
| (1) Body | (5) Ball | (9) Adjust screw |
| (2) Plug | (6) Detent ball | (10) Adjust nut |
| (3) Spool Assembly | (7) Nut | (11) Lever |
| (4) Spring | (8) Detent housing | (12) Pin |

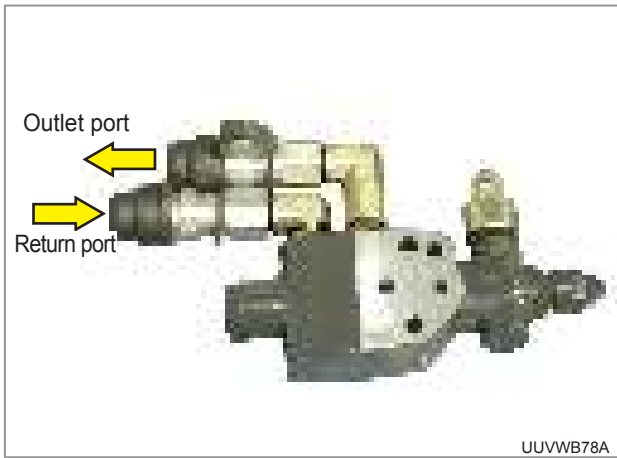

Even though the auxiliary hydraulic valve is a single acting type valve, it is equipped with one outlet port and one return port, which is distinct from the single acting valve in the tractor. This means that this single acting valve can operate the hydraulic motor by the hydraulic oil from its outlet port while the returning oil is returned to the oil tank through its return port.

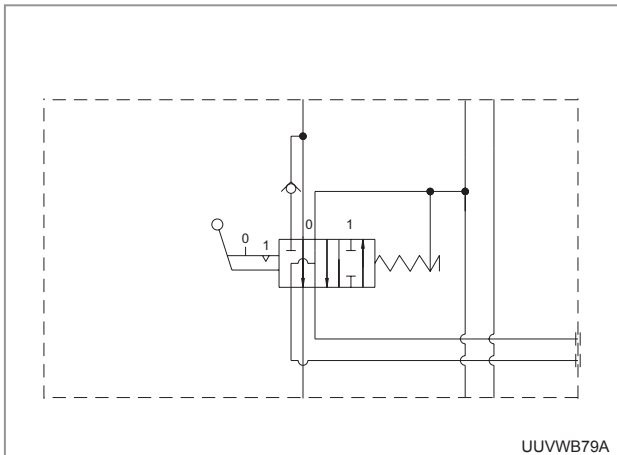

The auxiliary hydraulic valve is a add-on type which can be assembled with the dumping kit installed.

SAFETY FIRST

GENERAL

ENGINE

CVT

TRANSMISSION

CHASSIS

REAR AXLE

BRAKE

FRONT AXLE

STEERING

HYDRAULIC

ELECTRIC

INDEX

3. TROUBLESHOOTING

Symptom	Possible cause	Remedy
Impossible to extend dumping cylinder or slow extending speed	<ul style="list-style-type: none"> Faulty hydraulic pump Broken control valve or incorrect installation Faulty relief valve Faulty hydraulic piston seal Insufficient operating oil 	<ul style="list-style-type: none"> Replace Inspect or replace Inspect or replace Replace Add oil
Impossible to retract dumping cylinder	<ul style="list-style-type: none"> Faulty control valve or foreign material entered 	<ul style="list-style-type: none"> Inspect or, clean replace
Dumping cylinder retracted with no operation	<ul style="list-style-type: none"> Faulty control valve Faulty hydraulic piston seal Worn cylinder 	<ul style="list-style-type: none"> Inspect or replace Replace Replace
Vibration and noise	<ul style="list-style-type: none"> Insufficient operating oil Relief valve operated 	<ul style="list-style-type: none"> Add oil Adjust
Excessively hot oil temperature	<ul style="list-style-type: none"> Insufficient operating oil Faulty hydraulic pump High relief pressure 	<ul style="list-style-type: none"> Add oil Replace Adjust

SAFETY FIRST

GENERAL

ENGINE

CVT

TRANSMISSION

CHASSIS

REAR AXLE

BRAKE

FRONT AXLE

STEERING

HYDRAULIC

ELECTRIC

INDEX

4. INSPECTION AND ADJUSTMENT

4.1 MAIN RELIEF VALVE PRESSURE

CAUTION

- Make sure to check the oil level and add oil if necessary before the test as an insufficient oil level can cause malfunction in the hydraulic device during the test.



UUVWB14A

1. Prepare the pressure gauge that its measurable pressure is over 200 kgf/cm² and is equipped with the connector.
2. Disconnect the dumping cylinder hose of the dumping valve.
3. Attach the pressure gauge to the connector of the lifting side on the dumping valve hydraulic outlet port.

REMARK

- Stop the engine so that the pressure gauge can be easily attached. Then, move the double acting lever (dumping operation lever) forward and backward to remove pressure from the hydraulic line.

4. Place the selector shift lever in the neutral position, start the engine and speed up the engine to its maximum.
5. Move the dumping operation lever to the operating position and check the pressure during the relief open with the pressure gauge
6. As the main relief valve is open, complete the measurement within 20 to 30 seconds and return the lever to the neutral position.

Main relief setting pressure.....105 kgf/cm²
10.3 MPa
1,493 psi

7. If the main relief valve pressure is below the specified pressure, it is possible that the main relief valve is malfunctioning and the pump efficiency is deteriorated.

REMARK

HOW TO ADJUST RELIEF VALVE PRESSURE

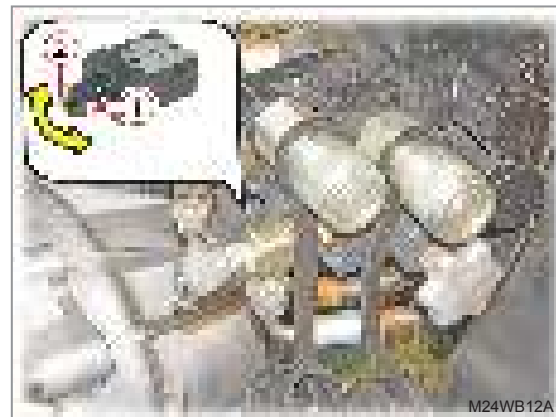

M24WB12A

- Adjust the relief valve pressure by unscrewing the adjusting nut (1) and turning the adjusting screw (2).
- Turning the adjusting screw clockwise with a hex. wrench increases the set pressure while turning it clockwise decreases the set pressure.

SAFETY FIRST

GENERAL

ENGINE

CVT

TRANSMISSION

CHASSIS

REAR AXLE

BRAKE

FRONT AXLE

STEERING

HYDRAULIC

ELECTRIC

INDEX

4.2 EXTERNAL HYDRAULIC PRESSURE

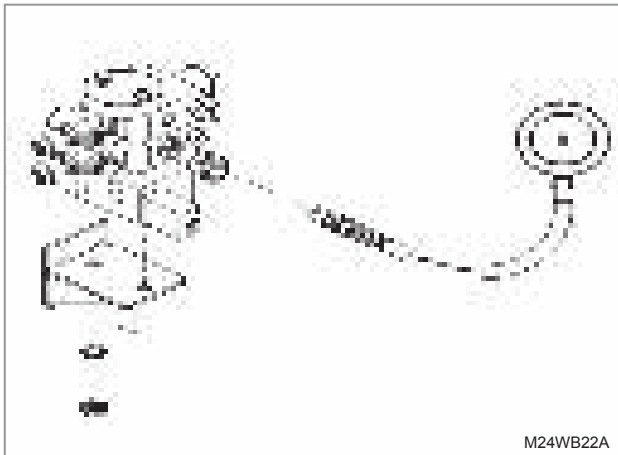

1. Connect the pressure gauge (0 ~ 250 kgf/cm²) to the hydraulic coupler socket as shown in the figure.
2. Start the engine and warm up the hydraulic system until the hydraulic oil gets warm properly.
3. Set the engine rpm to the maximum level and operate the external hydraulic control lever. Then, check the pressure.
 - Proper pressure : 100 ~ 110 kgf/cm²

5. DISASSEMBLY, SERVICE AND ASSEMBLY

5.1 GEAR PUMP DISASSEMBLY AND ASSEMBLY

5.1.1 GEAR PUMP REMOVAL

1. Park the vehicle on level ground and apply the parking brake.
2. Lift the cargo bed using the dumping operation lever and stop the engine.

⚠ CAUTION

- To prevent an injury by the falling cargo bed accidentally, set the support between the cargo bed and frame.



3. Disconnect the hose on the hydraulic flange side from the oil tank as well as the hydraulic hose P on the bottom of the gear pump. Then, unscrew the mounting bolt (1) to remove the hydraulic flange.

📖 REMARK

HYDRAULIC HOSE P (UNDER THE GEAR PUMP) TIGHTENING TORQUE

- Hydraulic hose P.....49.0 Nm
5.0 kgf-m
36.0 lb-ft
- Elbow nut.....24.5 Nm
2.5 kgf-m
18.0 lb-ft



UUVWB16A

4. Unscrew the gear pump mounting bolts (1) to remove the gear pump assembly.

REMARK

- Inspect the gasket. If it is not intact, replace it with a new one.

5.1.2 GEAR PUMP DISASSEMBLY



UUVWB18A

1. Unscrew the gear pump assembly mounting bolts (1).

REMARK



UUVWB20A

- Before disassembling the gear pump, mark a mating line between the rear cover and case to avoid faulty installation.

SAFETY FIRST

GENERAL

ENGINE

CVT

TRANSMISSION

CHASSIS

REAR AXLE

BRAKE

FRONT AXLE

STEERING

HYDRAULIC

ELECTRIC

INDEX

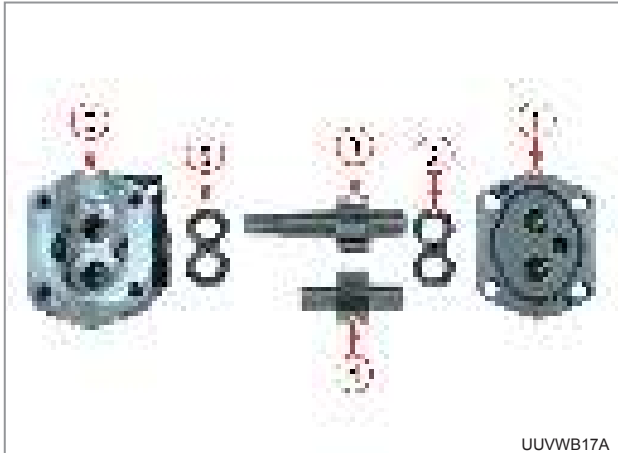

UUVWB17A

- Remove the rear cover (1), seal block (2), drive gear shaft (3), driven gear (4), seal block (5) and case (6) in order. If necessary, remove the snap ring and oil seal in the case.
- Assemble in the reverse order of disassembly.



UUVWB19A

- When installing the seal block, make sure that its opening is toward the mark "IN" (marked on the back of the rear case) and the seal attaching surface is toward the opposite of the gear.

5.2 AUXILIARY HYDRAULIC VALVE, DUMPING VALVE AND FRONT BLOCK (RELIEF VALVE) DISASSEMBLY AND ASSEMBLY (OPTIONAL)

5.2.1 VALVE REMOVAL

- Park the vehicle on level ground, stop the engine and apply the parking brake.



M24WB08A



UUVWB39A

- Disconnect the double acting cable (2), dump cable (3) and dumping cylinder hose (4) from the adapter (1). Then, unscrew the mounting bolts (5) (M10, 2 EA) to remove the cover (6) and double acting valve.

REMARK



- The hydraulic port for the auxiliary hydraulic valve is a flat-face type to prevent any foreign material from entering the hydraulic circuit through the hydraulic coupler during operation.

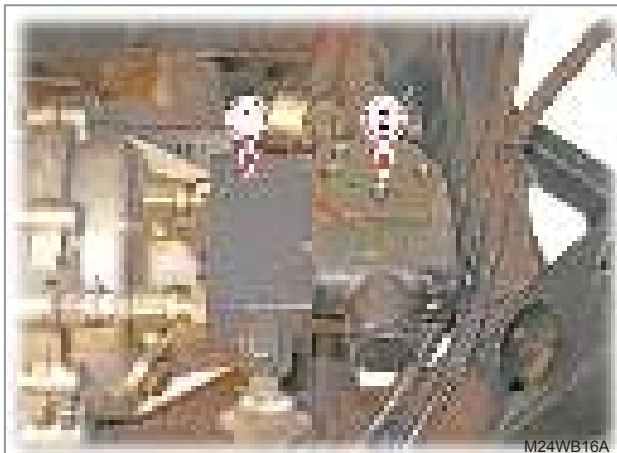

3. Remove the side block (1) and dumping valve (2).

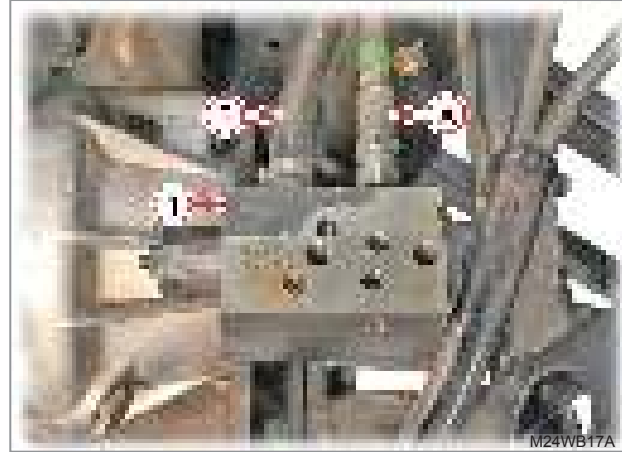

4. Disconnect the hydraulic hose P (A) and hydraulic hose T (B) on the front block side and remove the front block (1).

CAUTION

- When disassembling or assembling the hydraulic valve or cover, be careful not to damage the O-ring and make sure to apply a sufficient amount of oil to the surface of the O-ring before installation.

SAFETY FIRST

GENERAL

ENGINE

CVT

TRANSMISSION

CHASSIS

REAR AXLE

BRAKE

FRONT AXLE

STEERING

HYDRAULIC

ELECTRIC

INDEX

5.2.2 AUXILIARY HYDRAULIC VALVE DISASSEMBLY



UUVWB24A

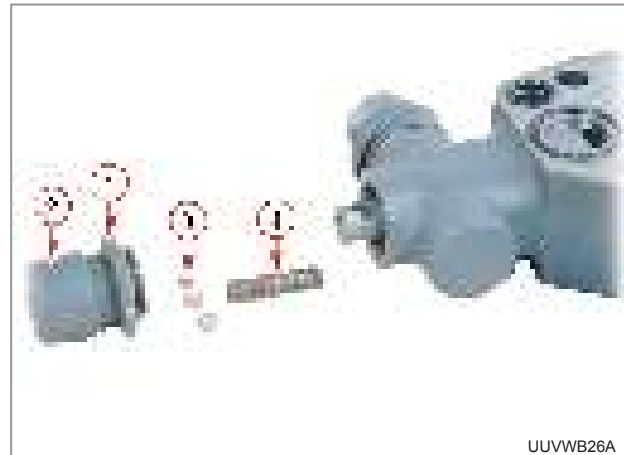

UUVWB26A

2. Unscrew the detent housing mounting nut (1) and remove the detent housing (2), ball (3) and spring (4).



UUVWB25A

1. Unscrew the adjusting nut (1) and remove the adjusting screw (3) with the detent ball (2). Count the number of threads of the adjusting screw protruded from the nut (for later installation).

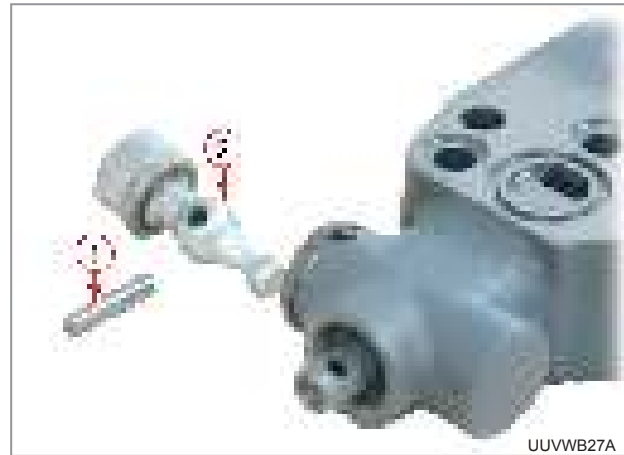

UUVWB27A

3. Pull out the lever fixing pin (1) and pull up the lever (2) to remove it.

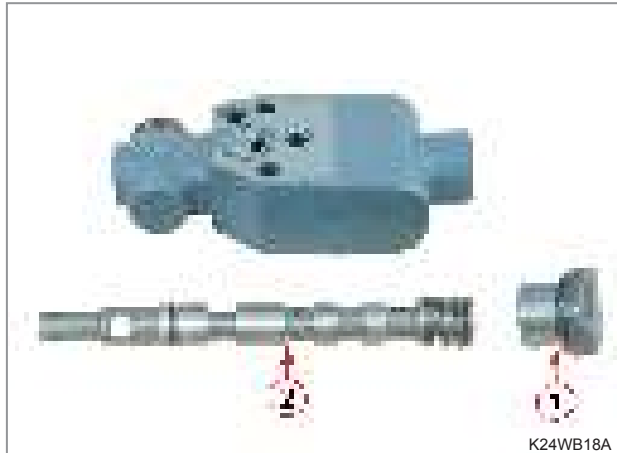

4. Unscrew the plug (1) and pull out the spool (2).

! IMPORTANT

- During disassembly and assembly, be careful not to damage the O-ring. If it is not intact, replace with a new one and apply a sufficient amount of oil on the new one before installation.



5. Assemble in the reverse order of disassembly.

SAFETY FIRST

GENERAL

ENGINE

CVT

TRANSMISSION

CHASSIS

REAR AXLE

BRAKE

FRONT AXLE

STEERING

HYDRAULIC

ELECTRIC

INDEX

● ASSEMBLY



1. When installing the detent ball, insert the spring into the spool, apply grease to the balls (1) and insert them to the three holes of the spool. Then, place the detent ball (2) onto the spring.



2. After installing the detent housing (1), press the detent ball into the position below the three balls in the spool with a tool to lower down the detent housing.



3. Fit the tool into the hole of the lever (1) as shown in the figure to fix the spool in position. Then, tap the detent housing with a hammer to screw it to the valve body.

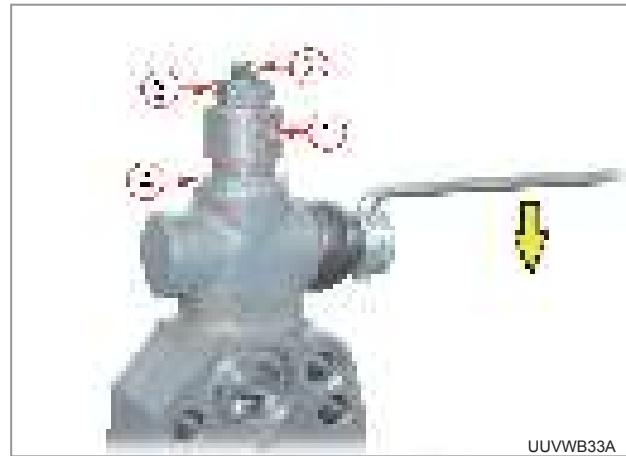

4. After screwing the detent housing (1) into the valve body, install the adjusting screw (2) and adjusting nut (3) and lower the lever in the arrow direction to the detent position (lever fixing (not returning) position). Then, tighten the detent housing mounting nut (4) to secure the housing. At this time, set the number of the adjusting screw threads protruded from the adjusting nut to be the same before its removal.

5.2.3 DUMPING VALVE DISASSEMBLY (AU:STD, US/EU:OPT.)



1. Unscrew the plug (1).



2. Pull out the lever fixing pin (1) and pull up the lever (2) to remove it with the bellows (3).

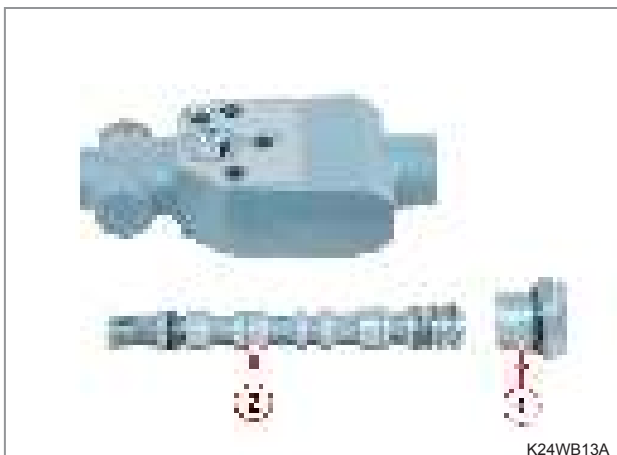

3. Unscrew the plug (1) and pull out the spool (2).

CAUTION

- During disassembly and assembly, be careful not to damage the O-ring. If it is not intact, replace with a new one and apply a sufficient amount of oil on the new one before installation.

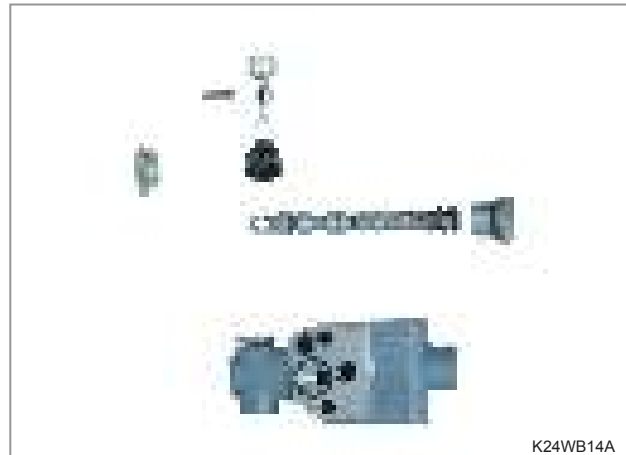

4. Assemble in the reverse order of disassembly.

SAFETY FIRST

GENERAL

ENGINE

CVT

TRANSMISSION

CHASSIS

REAR AXLE

BRAKE

FRONT AXLE

STEERING

HYDRAULIC

ELECTRIC

INDEX

5.2.4 FRONT BLOCK (RELIEF VALVE) DISASSEMBLY



UUVWB55A

1. Unscrew the plug (1) on the relief adjusting screw.



UUVWB56A

2. Remove the cover plug (1), spring (2), tappet (3) and spool (4) in order.

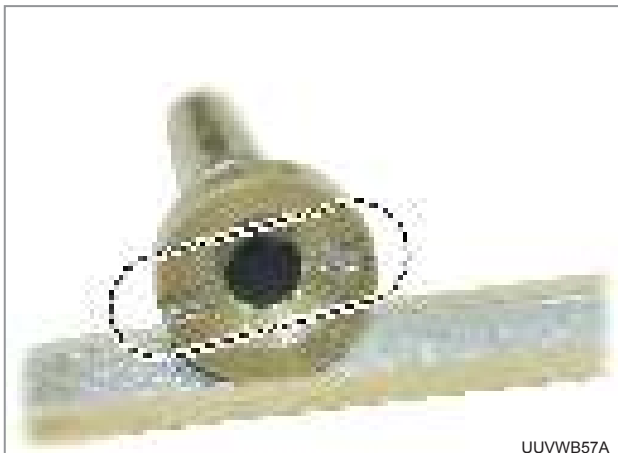

UUVWB57A

3. Remove the spool by turning it with a flat-bladed screwdriver.

REMARK

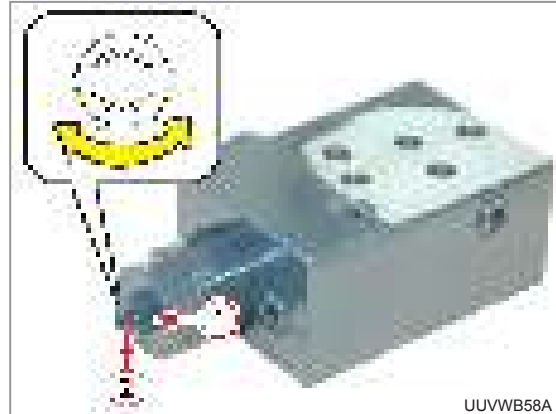

UUVWB58A

- Adjust the relief valve pressure by unscrewing the adjusting nut (1) and turning the adjusting screw (2).
- Turning the adjusting screw clockwise with a hex. wrench increases the set pressure while turning it counterclockwise decreases the set pressure.

4. Assemble in the reverse order of disassembly.

5.3 DUMPING CYLINDER DISASSEMBLY AND ASSEMBLY (AU:STD, US/EU:OPT.)

5.3.1 DUMPING CYLINDER REMOVAL

1. Park the vehicle on level ground and apply the parking brake.
2. Lift the cargo bed using the dumping operation lever and stop the engine.
3. Place the support between the cargo bed and frame so that the cargo bed does not fall down accidentally.



4. Remove the pin (1) and dumping cylinder hose from the dumping cylinder boss mounting bracket to separate the dumping cylinder.

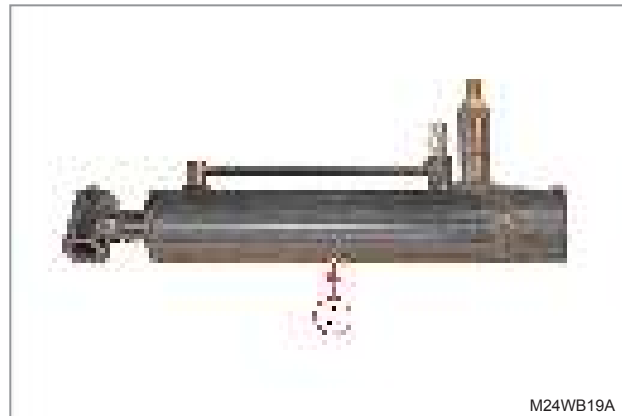

5. Remove the snap pin from the outside of the frame bracket. Then, remove the washer pin (2) to remove the dumping cylinder (3).

REMARK

Dumping cylinder - Lifting port, Lowering port and Connector

Tightening torque 34.3 Nm
3.5 kgf-m
25.2 lb-ft

SAFETY FIRST

GENERAL

ENGINE

CVT

TRANSMISSION

CHASSIS

REAR AXLE

BRAKE

FRONT AXLE

STEERING

HYDRAULIC

ELECTRIC

INDEX

5.3.2 DUMPING CYLINDER DISASSEMBLY

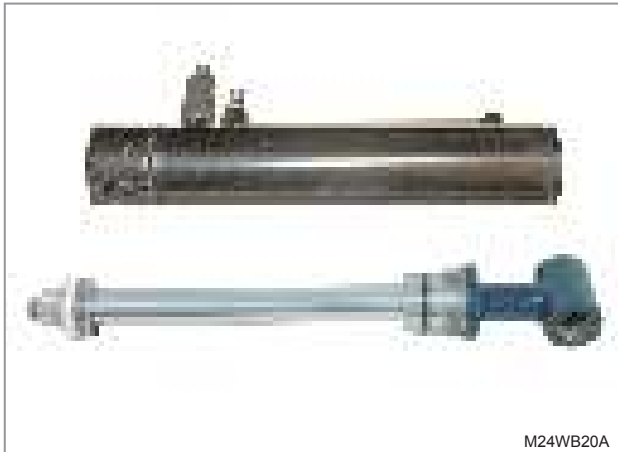

1. Turn the head cover (1) counterclockwise from the dumping cylinder to remove the piston rod assembly (using the notched groove).

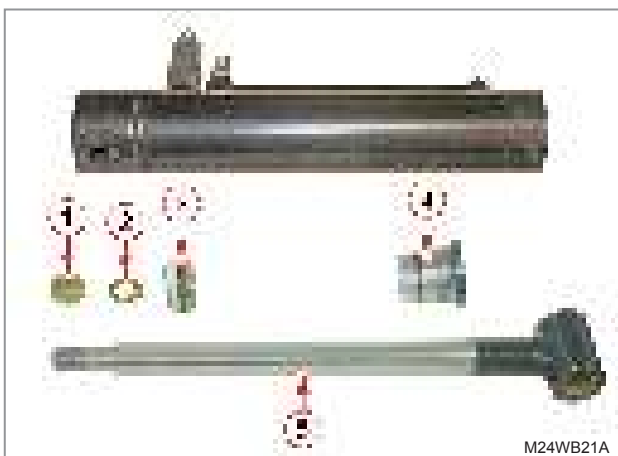

2. Secure the piston rod assembly in a vise and unscrew the nut to remove the nut (1), spring washer (2), piston assembly (3), head cover (4) and piston rod (5) in order.

! IMPORTANT



- When installing the head cover, check the condition of the O-ring (1). If it is not intact, replace with a new one and apply a sufficient amount of oil on the new one before installation.

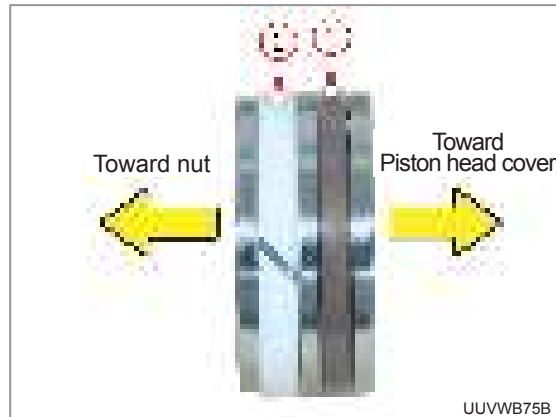

- When installing the piston, be careful not to switch the mounting locations of the piston packing (1) and wear ring (2). Also, be sure to install them in the correct direction.

6. EXPLODED VIEW

6.1 G513002 GEAR PUMP GROUP

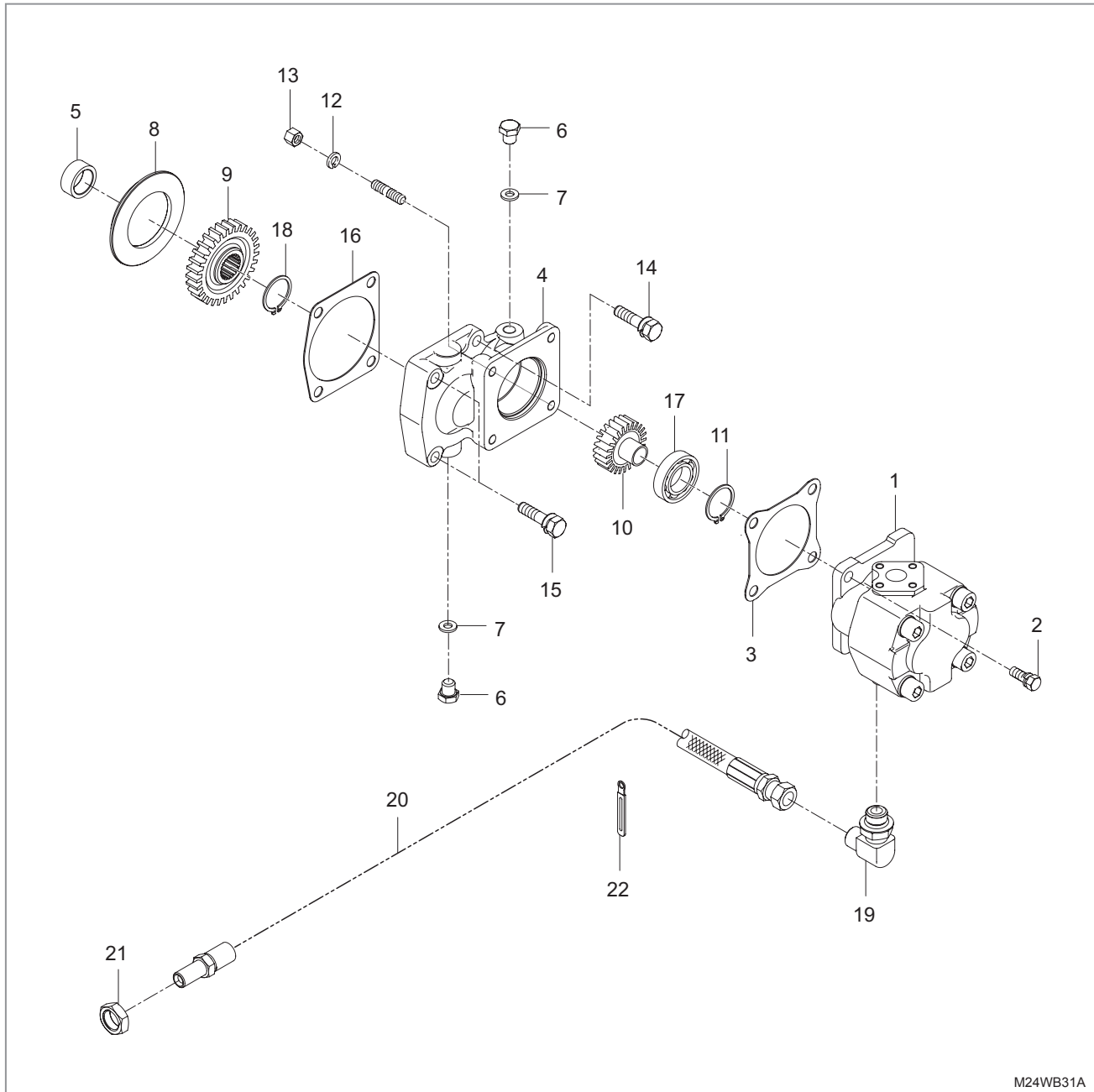

M24WB31A

COMPONENTS AND JOB CODES

- | | |
|---|----------------------------------|
| (1) Hydraulic Pump Assy (N030001) | (12) Spring Washer |
| (2) Bolt | (13) Nut |
| (3) Gasket | (14) Bolt |
| (4) Holder, HYD. Pump (N030002) | (15) Bolt, Washer |
| (5) Spacer, Gear Pump | (16) Gasket, Fuel Camshaft Cover |
| (6) Plug | (17) Ball Bearing |
| (7) Packing | (18) Ring, Snap |
| (8) Bush | (19) Elbow |
| (9) Gear, 29 Pump (N030005) | (20) Assy Hose, HYD-P1 (N030009) |
| (10) Shaft, Gear 18 Gear Pump (N030006) | (21) Nut |
| (11) Snap Ring | (22) Wirg Clamp |

SAFETY FIRST

GENERAL

ENGINE

CVT

TRANSMISSION

CHASSIS

REAR AXLE

BRAKE

FRONT AXLE

STEERING

HYDRAULIC

ELECTRIC

INDEX

- SAFETY FIRST
- GENERAL
- ENGINE
- CVT
- TRANSMISSION
- CHASSIS
- REAR AXLE
- BRAKE
- FRONT AXLE
- STEERING
- HYDRAULIC**
- ELECTRIC
- INDEX

6.2 G551004 CONTROL VALVE GROUP

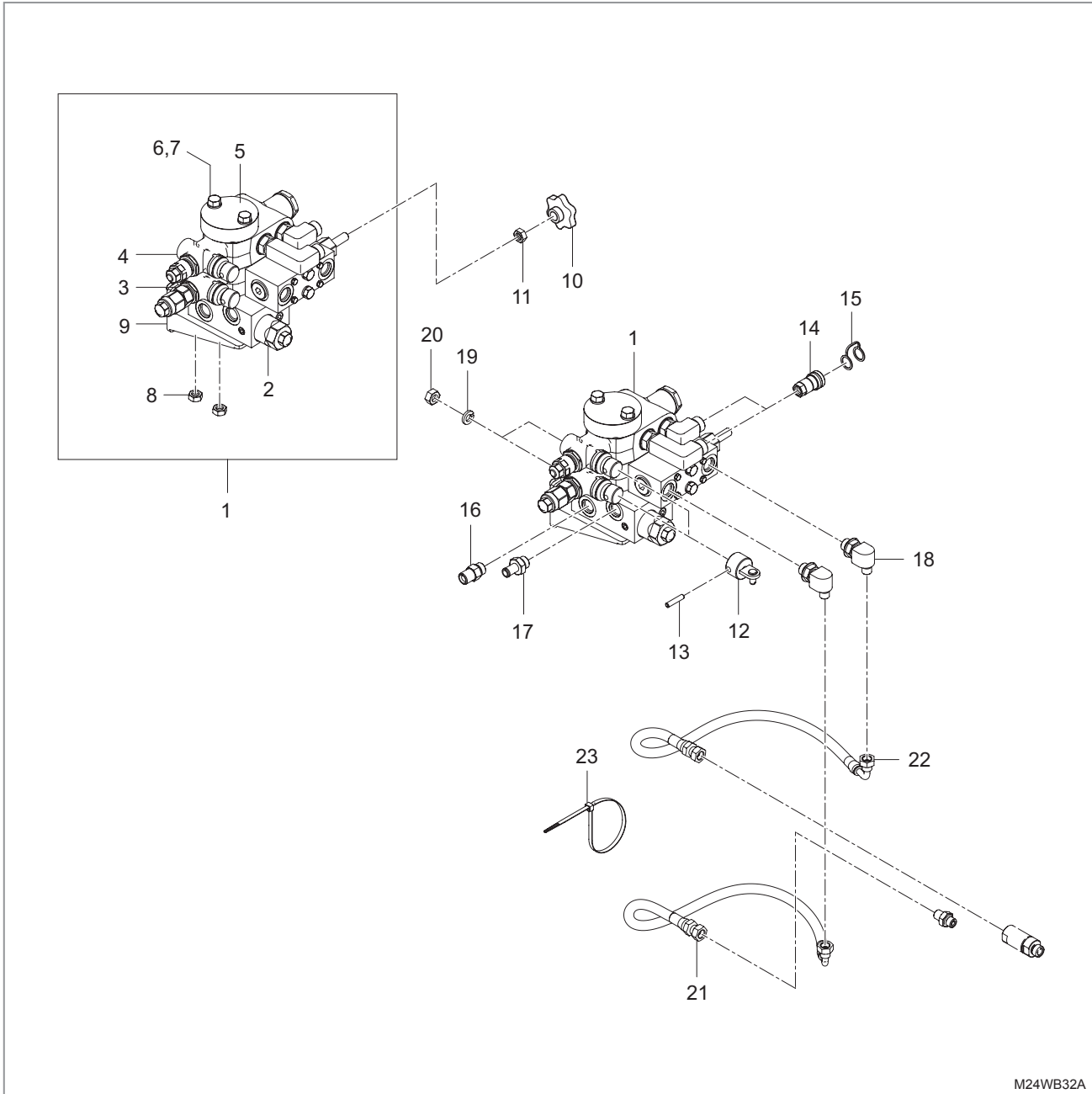

M24WB32A

COMPONENTS AND JOB CODES

- | | |
|---------------------------------------|---------------------------|
| (1) Hyd Valve Ass'y D | (13) Pin, Spring |
| (2) Front Block Assy | (14) Coupler (N070003) |
| (3) Detent Floating Valve | (15) Cap (N070004) |
| (4) Du-sectional Valve (N070001) | (16) Tube, Connecting |
| (5) Cover | (17) Connector |
| (6) Bolt | (18) Elbow |
| (7) Washer | (19) Spring_washer |
| (8) U-nut | (20) Nut |
| (9) Bracket - Cont. Valve (Bracket 2) | (21) Assy Hose, Cyl HYD-A |
| (10) Grip | (22) Assy Hose, Cyl HYD-B |
| (11) Nut | (23) Band, Cord |
| (12) Adaptor - Control Valve | |

6.3 G591002 DUMP CYLINDER GROUP

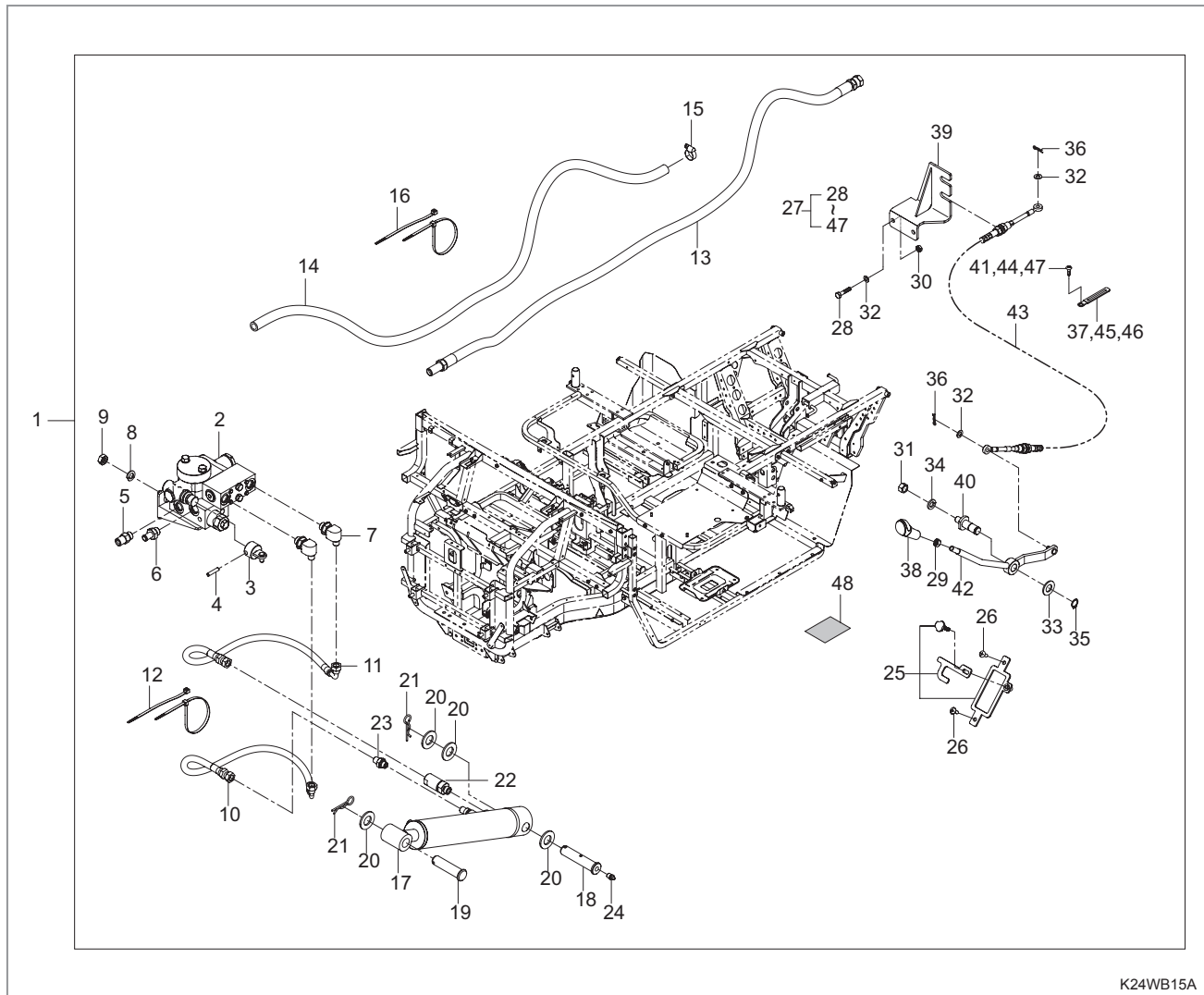

K24WB15A

COMPONENTS AND JOB CODES

- | | |
|--|---|
| (1) Assy, Hyd Kit(2) | (25) Hyd Lever Cover Assy (N060011) |
| (2) Hyd Valve Ass'y B (N060001, N060002) | (26) Screw (Black) |
| (3) Adaptor - Control Valve | (27) Dump Lever Assy, Complete |
| (4) Pin, Spring | (28) Bolt |
| (5) Tube, Connecting | (29) Nut |
| (6) Connector | (30) Nut |
| (7) Elbow | (31) Nut |
| (8) Spring_washer | (32) Washer |
| (9) Nut | (33) Washer, Plain |
| (10) Assy Hose, Cyl HYD-A (N060003) | (34) Spring_washer |
| (11) Assy Hose, Cyl HYD-B (N060004) | (35) Snap Ring |
| (12) Band, Cord | (36) Pin, Snap |
| (13) Assy Hose, HYD-C1 (N060005) | (37) Clamp, Wire |
| (14) Hose, Drain (N060006) | (38) Grip (N060014) |
| (15) Band, Hose | (39) Bracket Assy - Control Valve Cable (Brack) (N060015) |
| (16) Band, Cord | (40) Shaft Lever Mtg. Hyd.(Pin) (N060016) |
| (17) Assy Cylinder, HYD-dump (N060007) | (41) Screw (Black) |
| (18) Pin, Cyl | (42) Dump Lever Assy (N060017) |
| (19) Pin, Joint | (43) Dump Cable Assy (N060018) |
| (20) Washer, Plain | (44) Screw (Black) |
| (21) Pin, Snap | (45) Clamp, Wire |
| (22) Orifice (N060009) | (46) Wirg Clamp |
| (23) Tube, Connecting | (47) Screw (Black) |
| (24) Nipple, Grease (N060010) | (48) Label Warning, Hyd Lever Lock |

SAFETY FIRST

GENERAL

ENGINE

CVT

TRANSMISSION

CHASSIS

REAR AXLE

BRAKE

FRONT AXLE

STEERING

HYDRAULIC

ELECTRIC

INDEX

SAFETY FIRST

GENERAL

ENGINE

CVT

TRANSMISSION

CHASSIS

REAR AXLE

BRAKE

FRONT AXLE

STEERING

HYDRAULIC

ELECTRIC

INDEX

6.4 G511002 OIL TANK GROUP

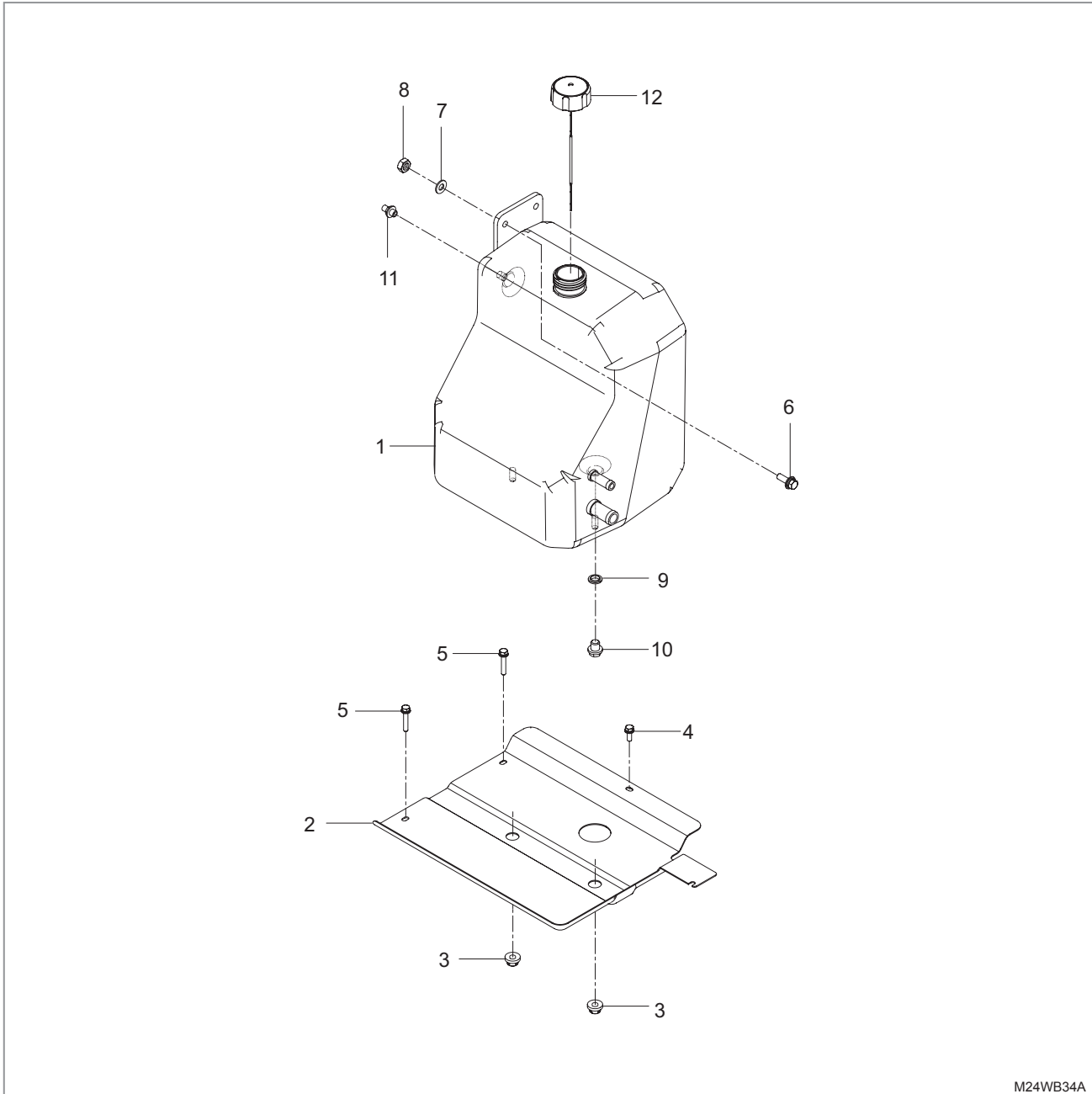

COMPONENTS AND JOB CODES

- | | |
|---------------------------------|-------------------------------|
| (1) Tank Assy - HYD. (N010001) | (7) Washer |
| (2) Bracket HYD. Tank (N010002) | (8) Nut |
| (3) Bushing-radiator | (9) Washer, Seal |
| (4) Bolt | (10) Plug (N010004) |
| (5) Bolt | (11) Connector |
| (6) Bolt, Washer | (12) Tank Cap Ass'y (N010005) |



K9 2400
K9 2440

ELECTRIC SYSTEM

CHAPTER 12

TABLE OF CONTENTS

1. SPECIFICATION	12-3	5.10 Coolant temperature sensor.....	12-39
2. CIRCUIT DIAGRAM	12-4	5.11 Fuel sender.....	12-42
2.1 Color code of wire.....	12-4	5.12 Alternator	12-43
2.2 Cross section of wire	12-4	5.13 Speed sensor.....	12-44
2.3 Symbols for electric components.....	12-5	5.14 Key switch.....	12-47
2.4 Overall circuit diagram	12-7	5.15 Combination switch.....	12-48
3. LOCATION OF ELECTRICAL DEVICES..	12-11	5.16 Flasher unit [K9 2400SW(GW) only]...	12-51
4. OPERATING PRINCIPLE	12-13	5.17 Power relay / glow relay.....	12-52
4.1 When the key switch is		5.18 Instrument panel.....	12-53
turned to "on" position.....	12-13	5.19 Power outlet.....	12-56
4.2 Preheating and post heating.....	12-16	5.20 Fuse & relay box.....	12-56
4.3 When the key switch is		5.20.1 Fuse box	12-56
turned to "start" position.....	12-19	5.20.2 Relay box	12-58
4.4 Fan motor operation	12-21	5.21 Brake lamp switch.....	12-61
4.5 ECU	12-23	5.22 ECU [K9 2400 SW(GW)].....	12-62
5. ELECTRICAL COMPONENTS	12-26	5.22.1 ECU diagnostic connector	12-63
5.1 Display unit	12-26	5.23 Actuator [K9 2400 SW(GW)].....	12-64
5.1.1 External wiring diagram		5.24 MPU(Magnetic Pick Up) sensor	
for display unit.....	12-27	[K9 2400 SW(GW)].....	12-65
5.2 Cooling fan motor	12-30	5.25 Atmospheric pressure sensor	
5.3 Bulb replacement.....	12-32	[K9 2400 SW(GW)].....	12-65
5.3.1 Headlamp.....	12-32		
5.3.2 Rear combination lamp	12-33	6. WIRING	12-67
5.4 Slow-blow fuse.....	12-35	6.1 Main harness	12-67
5.5 Glow plug.....	12-35		
5.6 Engine stop solenoid	12-36	7. DIAGNOSIS AND	
5.7 Parking brake switch.....	12-37	TROUBLESHOOTING	12-77
5.8 Neutral switch	12-38	7.1 General troubleshooting	12-77
5.9 Engine oil pressure switch.....	12-39	7.1.1 Battery.....	12-77
		7.1.2 Wiring.....	12-78
		7.1.3 General	12-80

TABLE OF CONTENTS

7.2 Troubleshooting	12-83	8. EXPLODED VIEW FOR THE COMPONENTS.....	12-95
7.2.1 When the engine cannot be started	12-83	8.1 G633001 Group for display control ...	12-95
7.2.2 When the system is not charged	12-85	8.2 G611001 Engine electrical components group (1).....	12-96
7.2.3 Check the charge warning lamp for malfunction.	12-86	8.3 G632001 Power socket group	12-97
7.2.4 When the system is not preheated manually	12-87	8.4 G631004 Wire harness group	12-98
7.2.5 When the system is not preheated automatically...	12-88	8.5 G633501 Fuel sender group	12-99
7.2.6 When high and low beams cannot be operated	12-91	8.6 G622502 Tail lamp group.....	12-100
7.2.7 Speedometer operation with the engine running.....	12-92	8.7 G615503 Safety starter group	12-101
7.2.8 Fuel gauge operation	12-94	8.8 G614501 Glow control group	12-102
7.2.9 Hour meter operation	12-95	8.9 G621001 Head light group	12-103

1. SPECIFICATION

Item	Specification
Battery	12V, 80AH Cold Cranking Ampere at -18°C : 630CCA Reserve capacity : 135 minutes L x W x H = 259 x 172 x 240mm
Start motor	12V, 1.7kW, Overall lengt : 240mm Pinion : spur, Module 3, 9 teeth
Alternator	12V, 50A Practical voltage output : 13.5V Pulley diameter : 64.3mm, (crank shaft pulley : 139mm) IC regulator installed in the alternator.
Slow blow fuse (Main, Power)	80A
Engine start relay	5P, 12V, 40~60A
Preheating relay, Power relay	4P, 12V, 70A
Pull coil relay for engine stop solenoid	5P, 12V, 20~30A
Glow plug	12V, 20A, Resistance at room temperature : 430Ω
Micro switch for parking brake	N.O type
Brake lamp switch	N.C type
Neutral switch	N.C type
Coolant temperature sensor	For temp gauge : approx. 2.45kΩ at 20°C For preheating : approx. 125Ω at 60°C
Engine oil pressure switch	On at 0.5 ± 0.1 kgf/cm ² (7 ± 1.4PSI) or below
Head lamp	12V, High beam:35W, Low beam:35W
Turn signal lamp	12V, 21W
Tail lamp	12V, 5W
Brake lamp	12V, 21W
Dash board bulbs	12V,1.4W
Fan motor	100W ± 10% (Max), 2060 rpm ± 10%
Fuel sender	"EMPTY" Position in 103 ~ 117 Ω "FULL" Position in 1 ~ 5 Ω
Speed sensor	Resistance between terminals : 2.2 ± 0.2 kΩ at 15°C
Flasher unit (US)	5P
Display unit	12V
Fan motor relay	5P, 12V, 40A
Power outlet	12 V, 10 A, Return time : 13 ± 5 sec. after pressing plug

SAFETY FIRST

GENERAL

ENGINE

CVT

TRANSMISSION

CHASSIS

REAR AXLE

BRAKE

FRONT AXLE

STEERING

HYDRAULIC

ELECTRIC

INDEX

2. CIRCUIT DIAGRAM

2.1 COLOR CODE OF WIRE

Code	Color	Code	Color	Code	Color
B	Black	BrR	Brown/Red	BY	Black/Yellow
L	Blue	RW	Red/White	LgR	Light green/Red
W	White	YR	Yellow/Red	LgW	Light green/White
Br	Brown	YW	Yellow/White	BL	Black/Blue
G	Green	WY	White/Yellow	LW	Blue/White
R	Red	Y	Yellow	GW	Green/White
BW	Black/White	Lg	Light green	RB	Red/Black
BR	Black/Red	Gr	Gray	LR	Blue/Red
YG	Yellow/Green	O	Orange	LB	Blue/Black
YBr	Yellow/Brown	P	Pink	RL	Red/Blue

The following figures are examples for colors according to the codes.

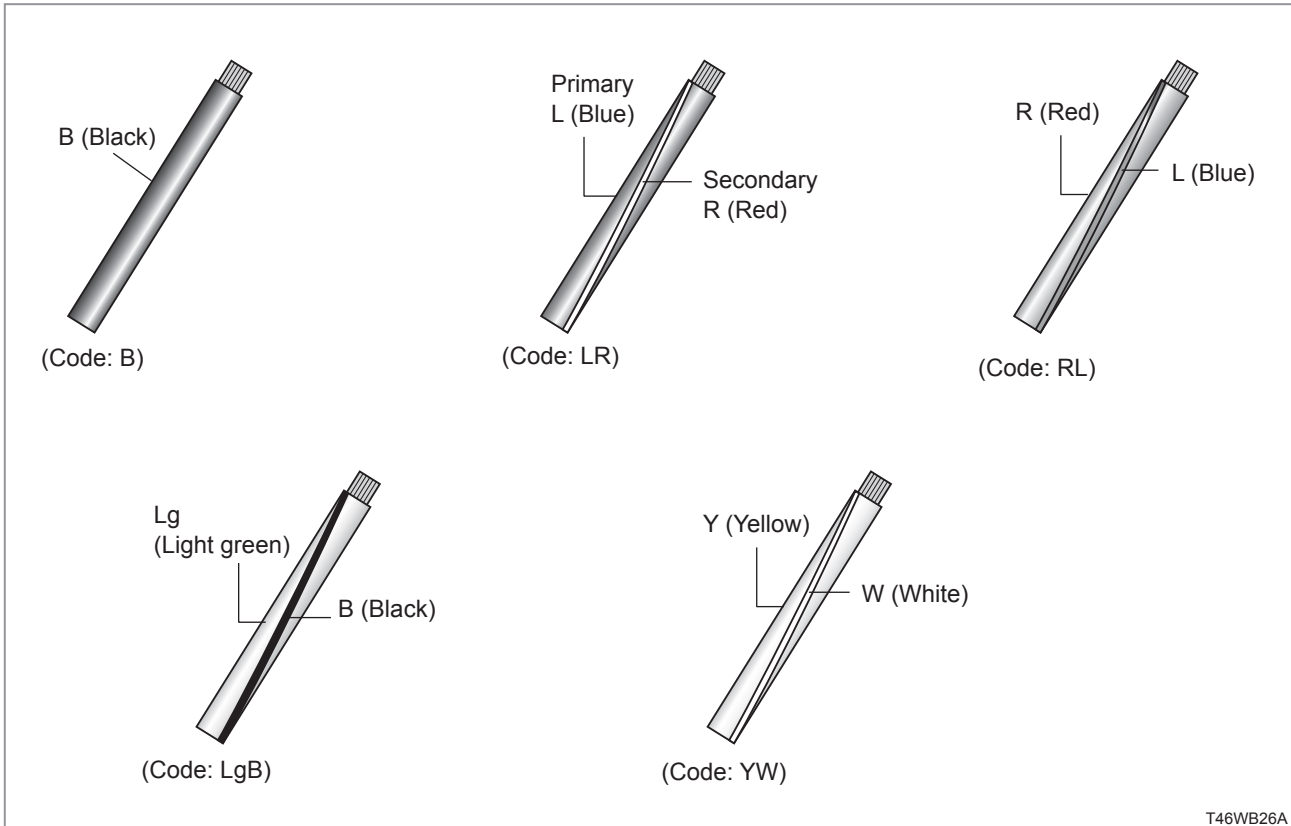

2.2 CROSS SECTION OF WIRE

1. Every wire has its own number for easy understanding and communication.
2. Every wire has its cross section area with color code ;
3. For instance "5.0 R" means red wire with 5 mm² cross section area, where, 5 mm²=π D² / 4, D= 2.523mm

2.3 SYMBOLS FOR ELECTRIC COMPONENTS

Symbol	Description	Symbol	Description
	Fuse		Single bulb
	Slow-blow fuse		Lamp
	Motor		Double bulb
	Switch (Normally Open Type)		Diode
	Switch (Normally Close Type)		Zener-diode
	Compressor		LED (Light Emitting Diode)
	Ground (Wire)		Photo Diode
	Ground (Chassis)		N.P.N Transistor
	Condenser/Capacitor		P.N.P Transistor
	Resistor		Meter
	Coil		Thermistor
	Battery		Speaker
	Disconnected wire		Pick up sensor
	Connected wire		Solenoid
	Connected wire	-	-

SAFETY FIRST
GENERAL
ENGINE
CVT
TRANSMISSION
CHASSIS
REAR AXLE
BRAKE
FRONT AXLE
STEERING
HYDRAULIC
ELECTRIC
INDEX





2.4 OVERALL CIRCUIT DIAGRAM

K9 2400SW / K9 2400GW

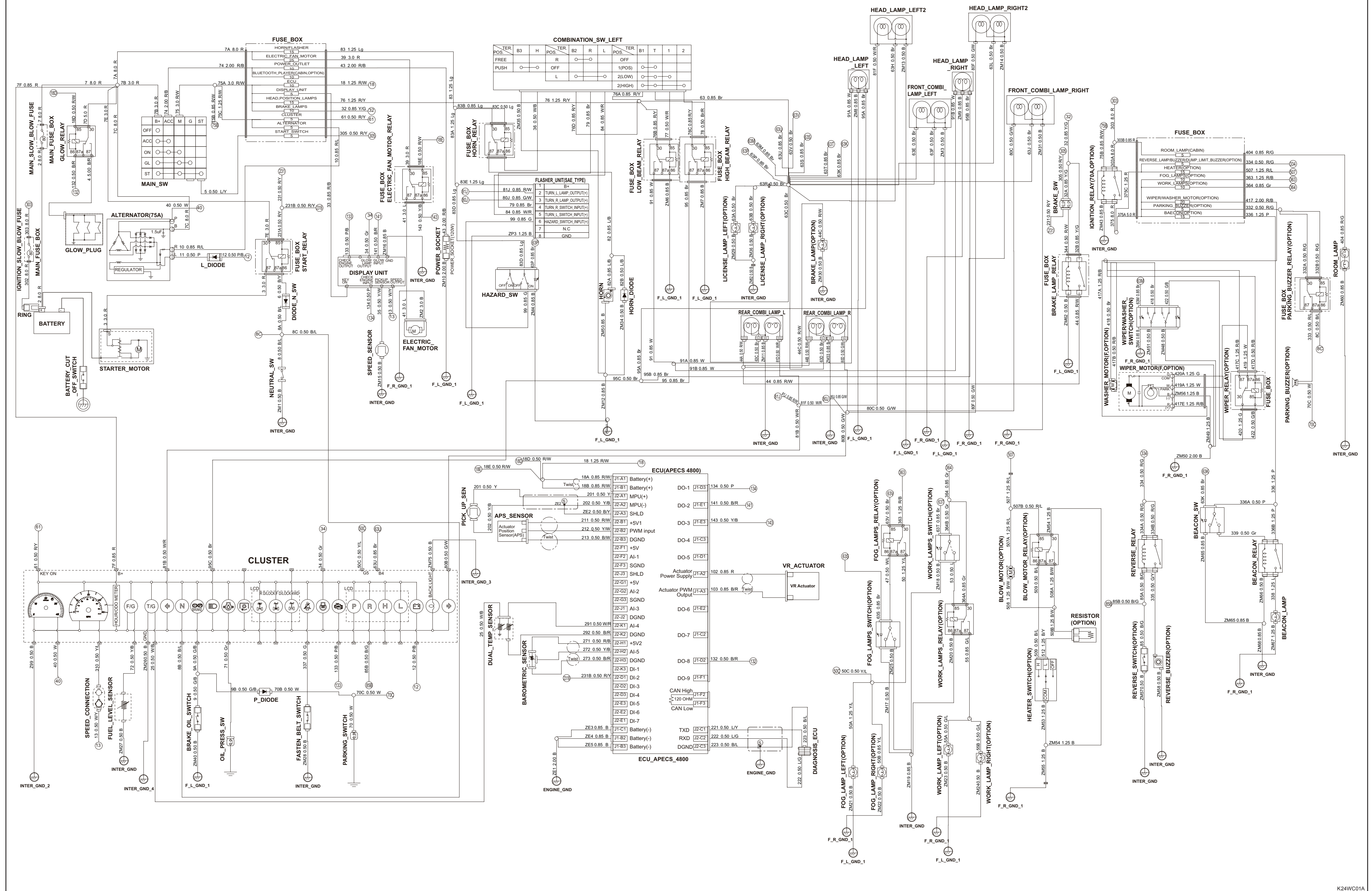

SAFETY FRST
GENERAL
ENGINE
CVT
TRANSMISSION
CHASSIS
REAR AXLE
BRAKE
FRONT AXLE
STEERING
HYDRAULIC
ELECTRIC
INDEX

K9 2400- EU

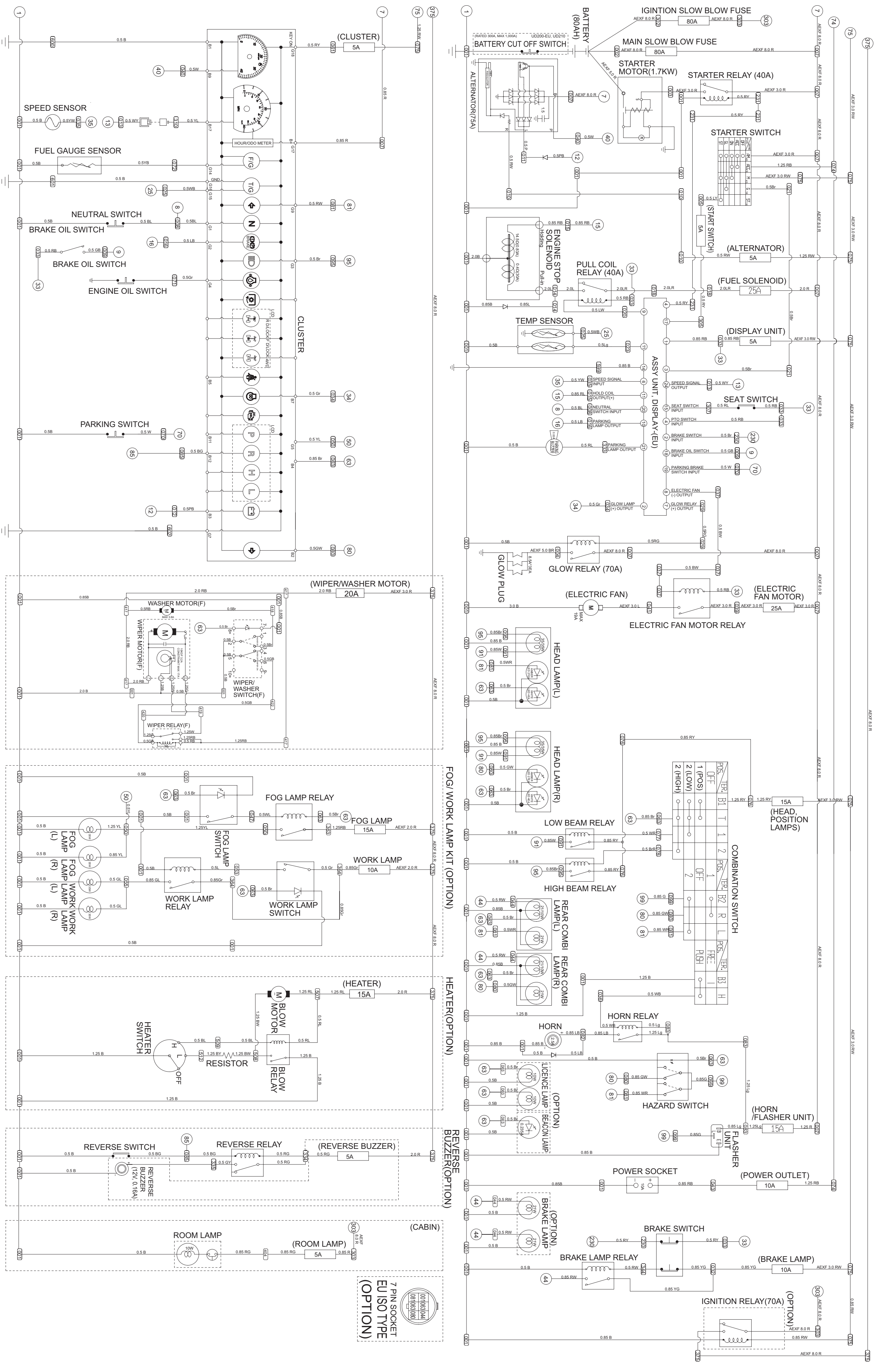





- SAFETY FIRST
- GENERAL
- ENGINE
- CVT
- TRANSMISSION
- CHASSIS
- REAR AXLE
- BRAKE
- FRONT AXLE
- STEERING
- HYDRAULIC
- ELECTRIC**
- INDEX

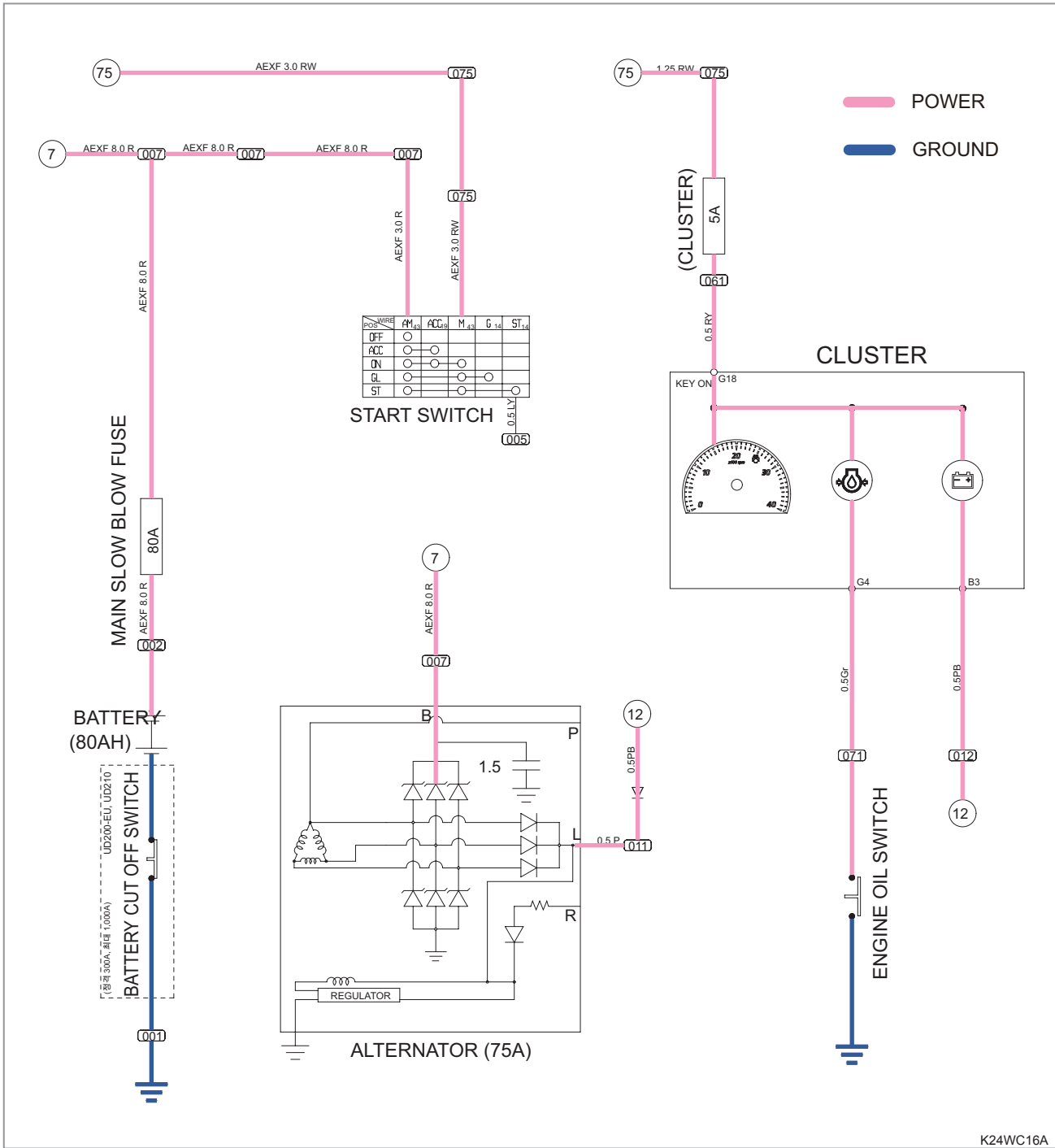

- Power supplied to the combi-meter flows through the charge warning lamp and diode on through to ground in the alternator to turn the charge warning lamp on. This ground circuit changes to 12V when the alternator is operating.

- Power supplied to the engine oil pressure switch (engine oil switch) will turn on the engine oil pressure warning lamp on the dash board because the pressure switch circuit is closed when the oil pressure is 7 psi (0.5 ± 0.1 kg/cm²) or less.

K9 2400 SW(GW)

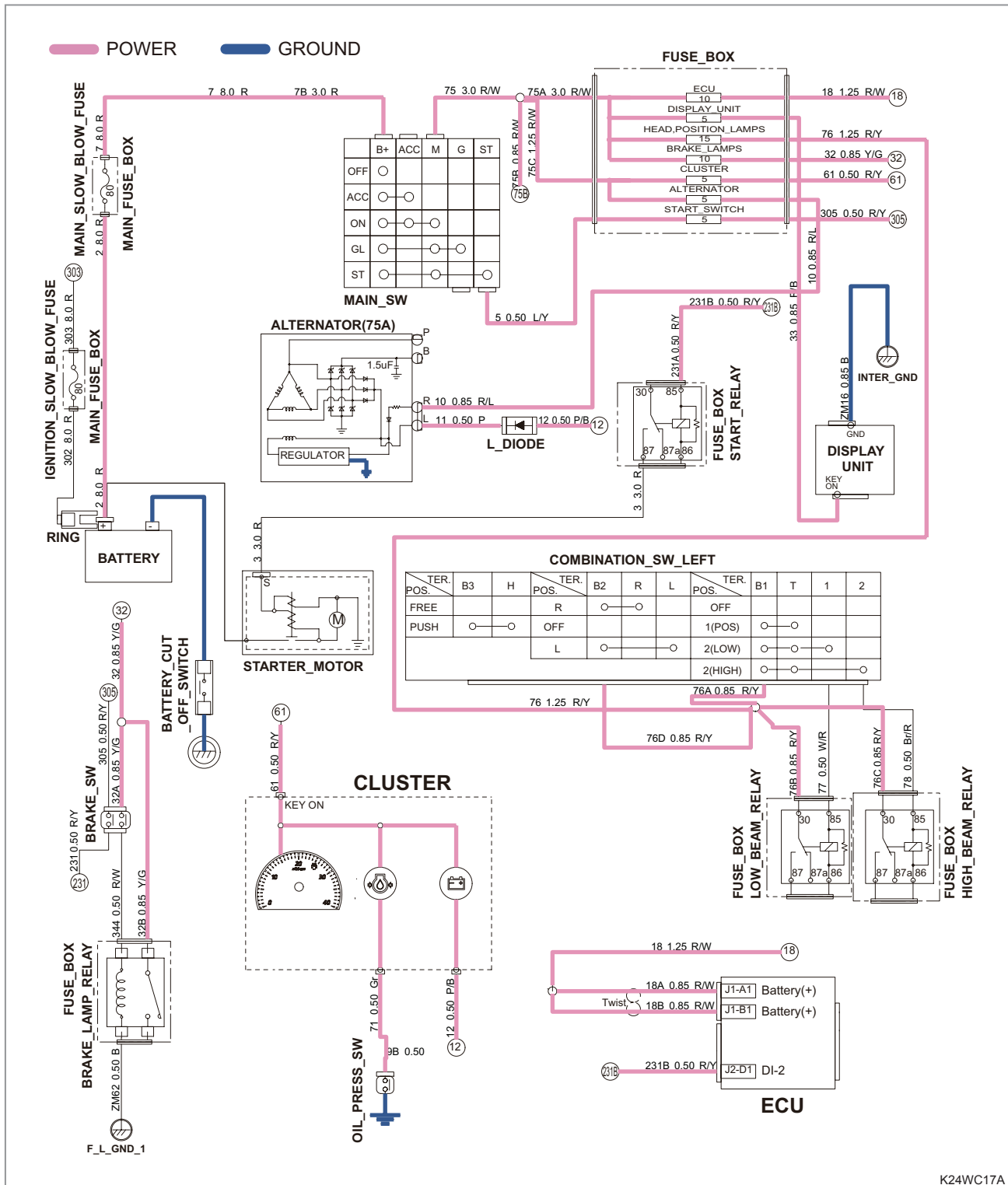

- SAFETY FIRST
- GENERAL
- ENGINE
- CVT
- TRANSMISSION
- CHASSIS
- REAR AXLE
- BRAKE
- FRONT AXLE
- STEERING
- HYDRAULIC
- ELECTRIC**
- INDEX

- When the ignition switch is turned to the "ON" position, power is supplied to the ECU, display unit, head lamp, brake lamp, cluster and alternator through the fuse box. ECU supplies power to the start relay, combination switch supplies power to the high-beam and low-beam relay in the fuse box, and brake supplies power to the brake lamp relay as standby power.

Main power supplied from the instrument panel supplies to the ground through the diode of the alternator and turns on the charge warning lamp of instrument panel. When engine oil pressure is below the specified value, the engine oil pressure switch is closed and turns on the engine oil pressure warning lamp of instrument panel.

4.2 PREHEATING AND POST HEATING

K9 2400D - AU, K9 2400 -EU

- SAFETY FIRST
- GENERAL
- ENGINE
- CVT
- TRANSMISSION
- CHASSIS
- REAR AXLE
- BRAKE
- FRONT AXLE
- STEERING
- HYDRAULIC
- ELECTRIC**
- INDEX

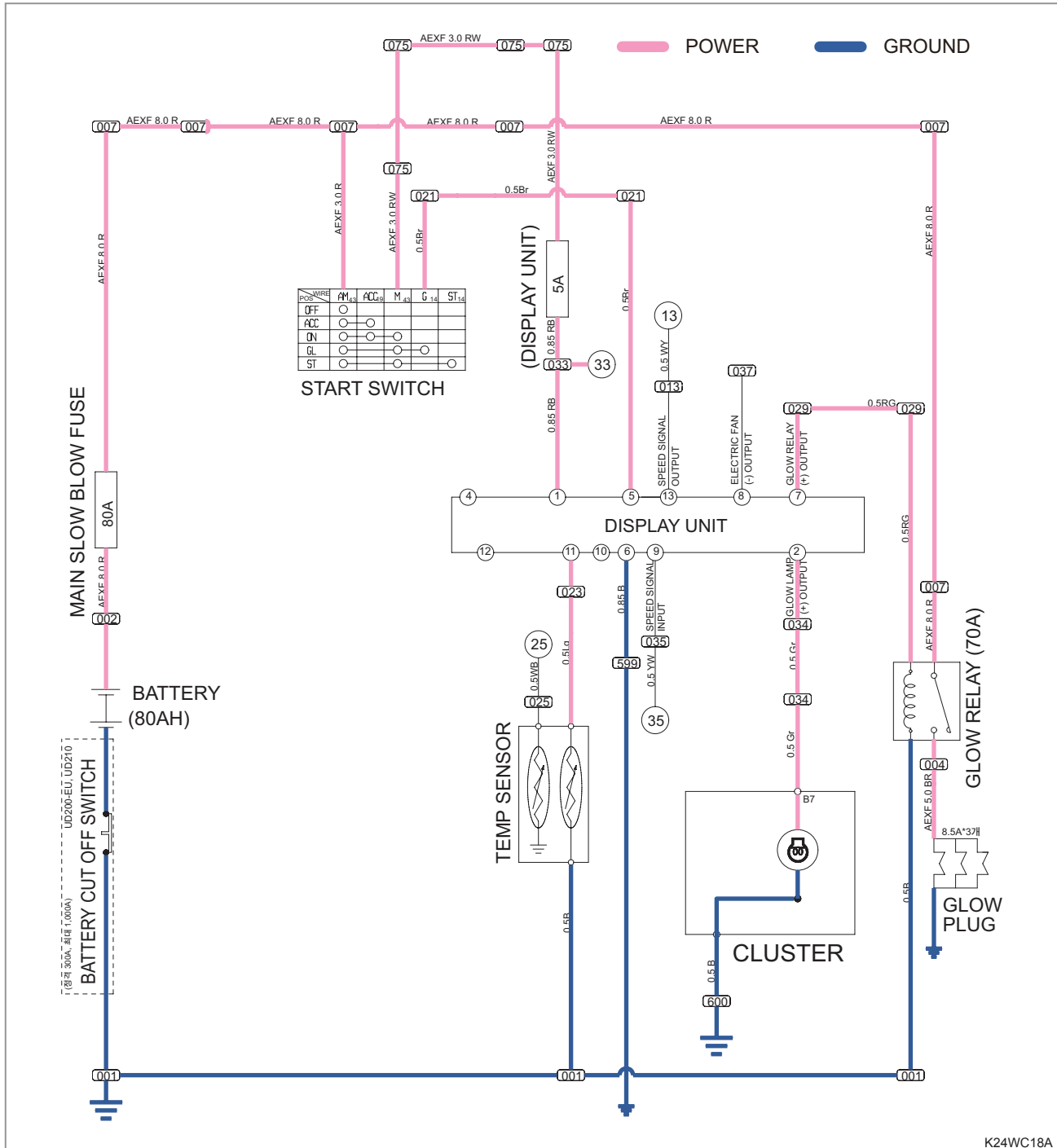

- When the key switch is turned to "ON" position, the display unit determines whether the preheating(or post heating) is necessary or not using temperature input signal from coolant temperature sensor. If the coolant is less than 30°C (86°F), the display unit gives the signal to glow relay to activate glow plugs for 15 seconds of preheating time. At the same time, the display unit also gives the power to glow indication lamp on the dash board for 8 seconds.
- The preheating seconds and indication seconds can be shortened by turning the key switch to start position and another 15 seconds of post heating starts when the key is returned to "ON" position. The indication lamp is not activated during the post heating period.

- The glow plugs can be activated manually by holding the key in between "ON" and "START" position.

REMARK

- The post heating process makes the combustion condition of engine better to reduce harmful emissions which can be produced a lot right after engine start in cold weather. It also helps engine to reach its normal running condition faster by expediting the warm-up process.

K9 2400 SW(GW)

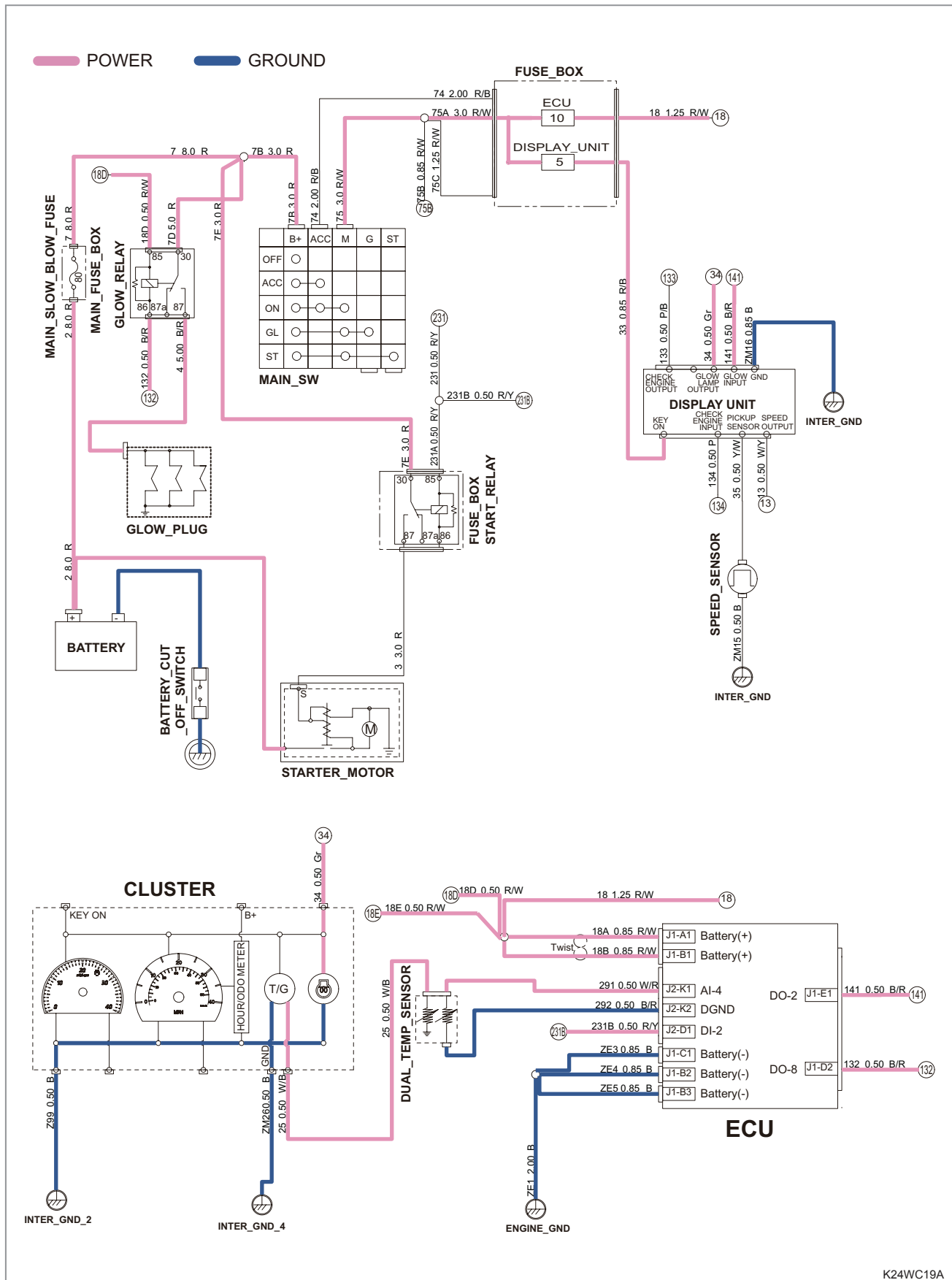

- SAFETY FIRST
- GENERAL
- ENGINE
- CVT
- TRANSMISSION
- CHASSIS
- REAR AXLE
- BRAKE
- FRONT AXLE
- STEERING
- HYDRAULIC
- ELECTRIC**
- INDEX

- SAFETY FIRST
- GENERAL
- ENGINE
- CVT
- TRANSMISSION
- CHASSIS
- REAR AXLE
- BRAKE
- FRONT AXLE
- STEERING
- HYDRAULIC
- ELECTRIC**
- INDEX

When the ignition switch is turned to the "ON" position and the coolant temperature is below 30°C, the preheating system is automatically activated. As the dual temperature sensor installed to the coolant flange sends the temperature signal to the ECU, the ECU determines the necessity of the preheating operation according to the key on power and temperature signals and sends an electric signal to the glow relay as necessary to start the preheating operation. Also, the ECU sends an electric signal to the display unit and the display unit turns on the preheat indicator on the combi-meter as soon as the preheating operation is activated. It is programmed to turn on the preheat indicator and perform the preheating operation as below. However, when the ignition switch is turned to the "START" position, the preheating operation is deactivated immediately. When the ignition switch is released from the "START" position, it is returned to the "ON" position and the post-heating operation is activated for 15 seconds. This post-heating operation is also controlled by the ECU. The post-heat operation is performed for 15 seconds unless the ignition switch is turned to the "OFF" or "START" position within this period. The post-heat operation is to eliminate possible incomplete combustion and excessive emission after the engine is started. This operation is not activated when the coolant temperature is over 30°C.

When ECU is installed, pre-heating is automatically controlled by ambient temperature. Therefore manual-heating is not activated.

Coolant temperature (Ambient temperature)	Pre-heating time	Pre-heating operation	Post-heating time
-15°C (5°F) or less	20 sec.	20 sec.	15 sec.
-15°C ~ 30°C (5°F ~ 86°F)	9 sec.	9 sec.	15 sec.
30°C (86°F) or more	N/A	N/A	N/A

► PRE-HEATING / POST-HEATING FLOW CHART

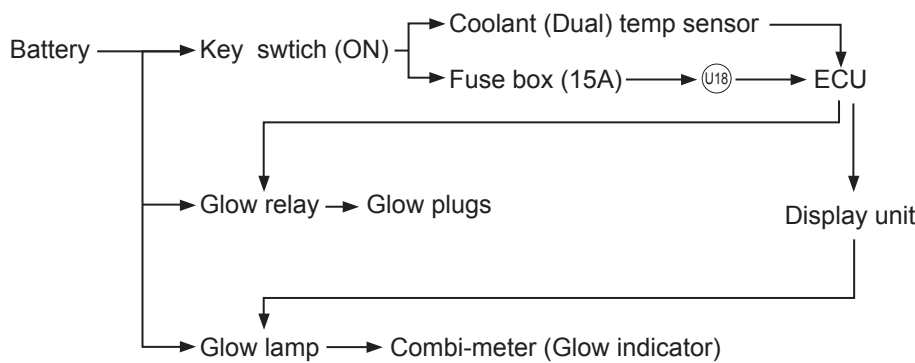

4.3 WHEN THE KEY SWITCH IS TURNED TO "START" POSITION

K9 2400D - AU, K9 2400 -EU

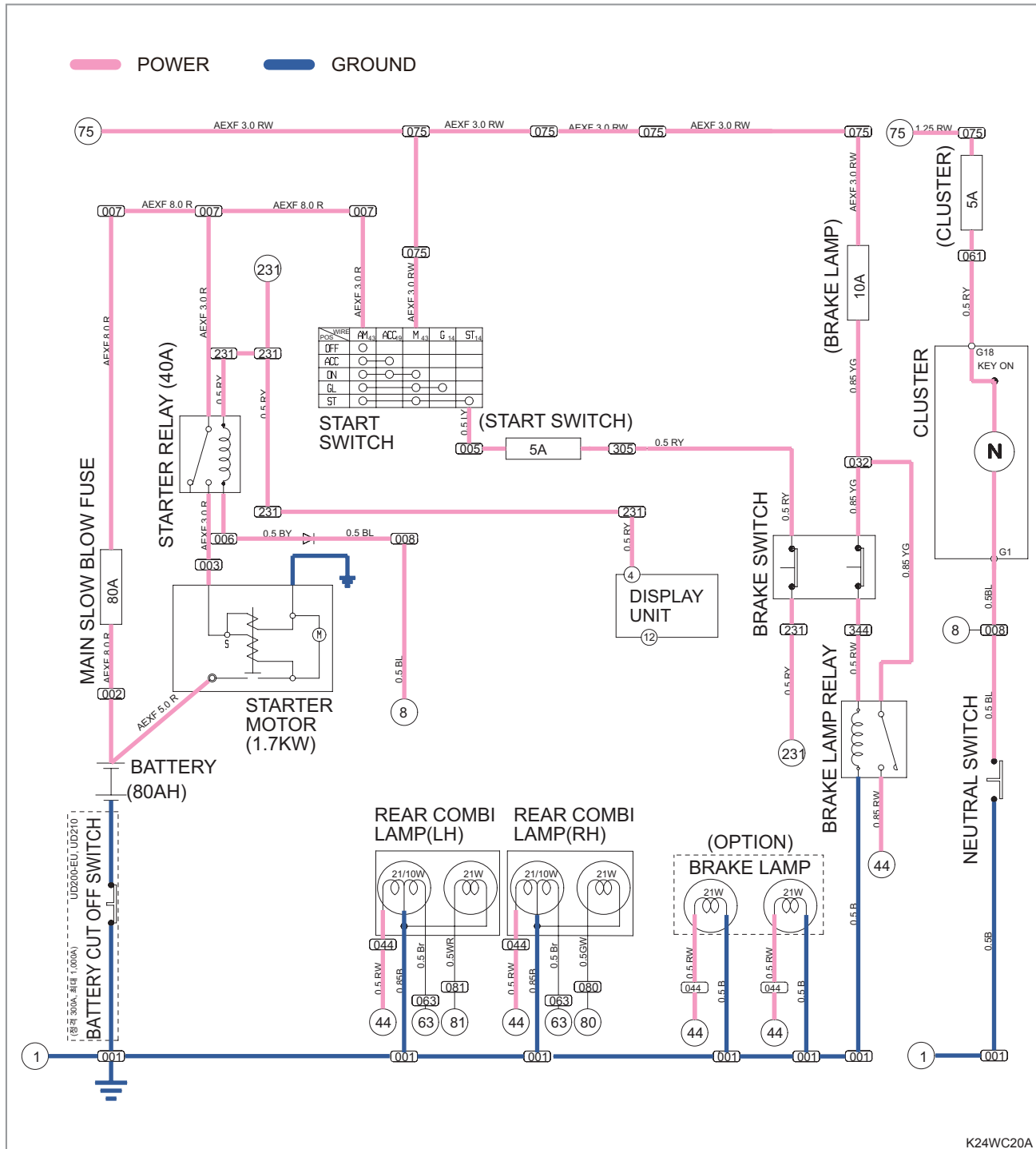

- The start signal from key switch activates start relay to engage start motor. However the start relay can not be activated when the negative line of start signal is open by the neutral switch which is mounted on the gear shift lever. The neutral switch is normally open and closed only when the gear shift lever is in its neutral position. Also, the start relay is connected when depressing the brake pedal and being brake switch "ON" and the starter motor is operated.

- SAFETY FIRST
- GENERAL
- ENGINE
- CVT
- TRANSMISSION
- CHASSIS
- REAR AXLE
- BRAKE
- FRONT AXLE
- STEERING
- HYDRAULIC
- ELECTRIC**
- INDEX

K9 2400 SW(GW)

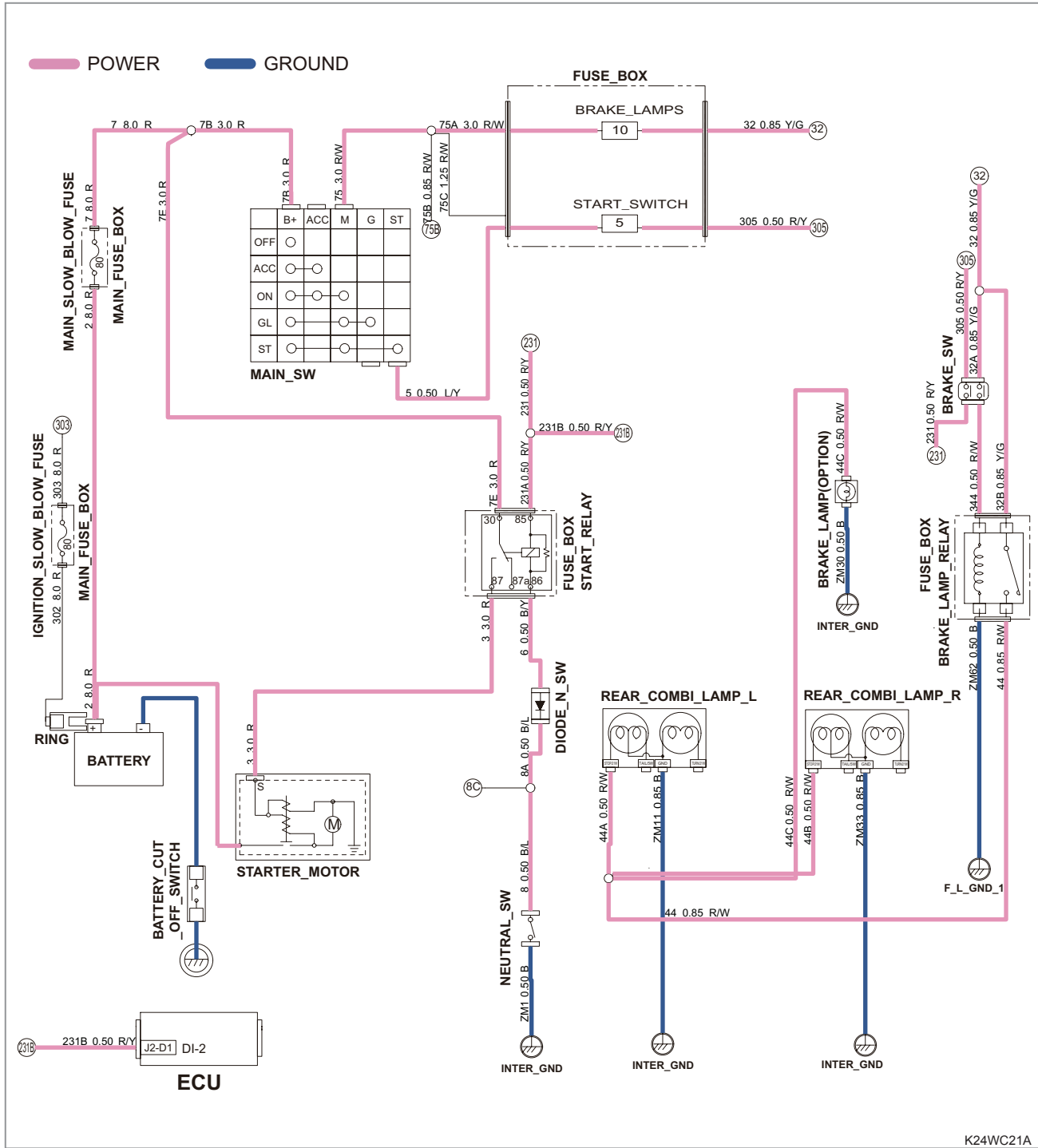

K24WC21A

- When the ignition switch is turned to the "ST" position, power is supplied to the brake switch through the starter switch fuse in the fuse box. As this power is supplied to brake switch and brake lamp relay through the brake lamp fuse in the fuse box. Also, battery power is supplied to the start relay and it will be standby mode.

When the engine start signal is detected on the ECU, power is supplied to the start relay. At this moment, the starter motor is operated when brake switch is "ON" and neutral switch is "N" position for continuity. On the other hand, brake switch is "ON" and it makes brake lamp relay is continuity. Then, the brake lamp of the rear combination lamp is turned on.

4.4 FAN MOTOR OPERATION

K9 2400D - AU, K9 2400 -EU

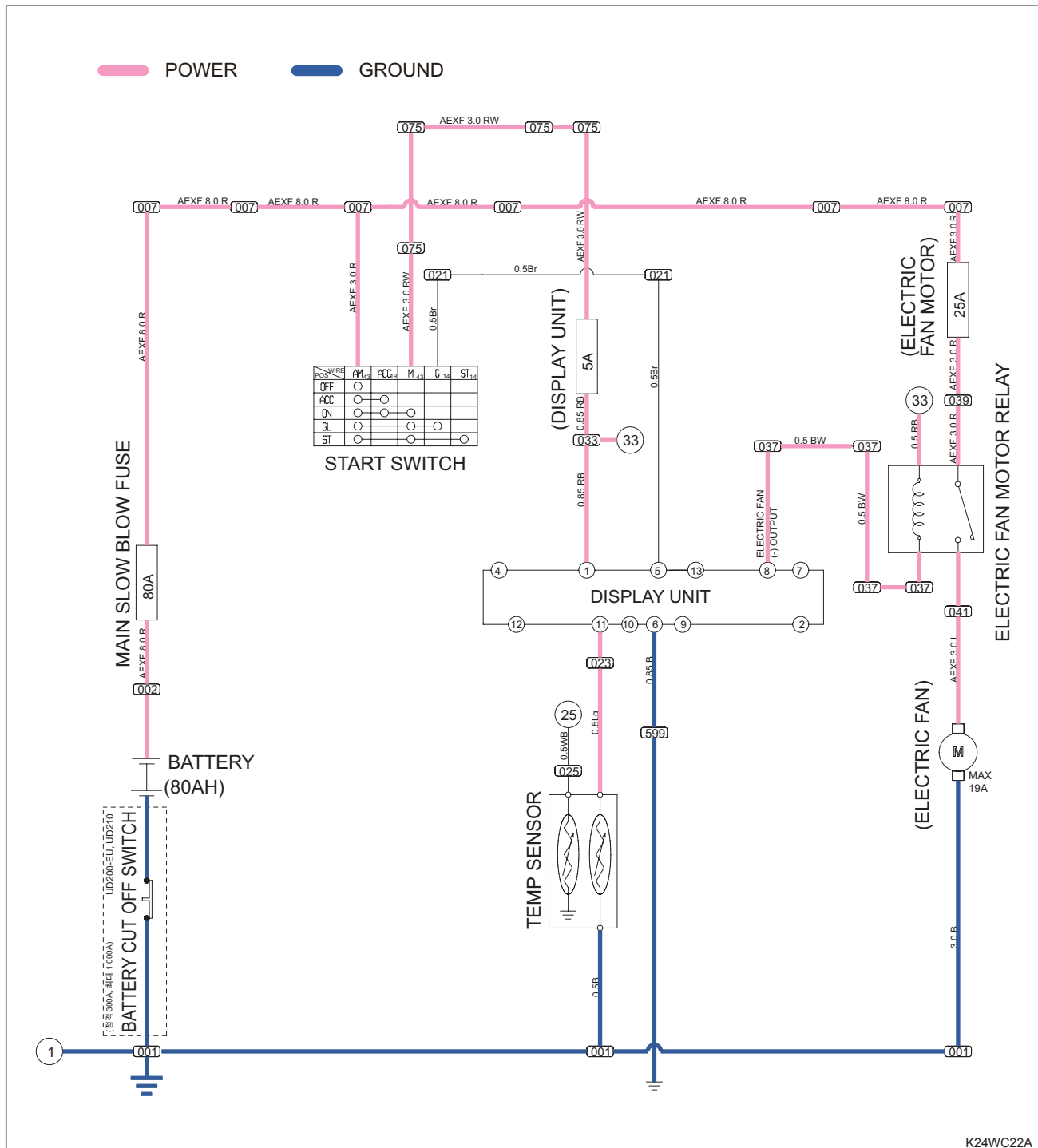

- When the key is in the "ON" position, the display unit controls radiator cooling fan motor in accordance with coolant temperature. It runs the fan motor when the coolant temperature raises over 80°C (176°F) and stops the fan motor when the coolant temperature drops below 75°C (167°F). The 5°C (41°F) gap between two points is to prevent continual "ON" and "OFF" operation of fan motor. The fan motor can run even when the engine is stopped if the key is in "ON" position and the coolant is still hot.

To prevent engine failure, the display unit keeps running fan motor even if there is any short-circuit (023) or disconnected wire on the temperature signal circuit.

- SAFETY FIRST
- GENERAL
- ENGINE
- CVT
- TRANSMISSION
- CHASSIS
- REAR AXLE
- BRAKE
- FRONT AXLE
- STEERING
- HYDRAULIC
- ELECTRIC**
- INDEX

4.5 ECU

K9 2400 SW(GW)

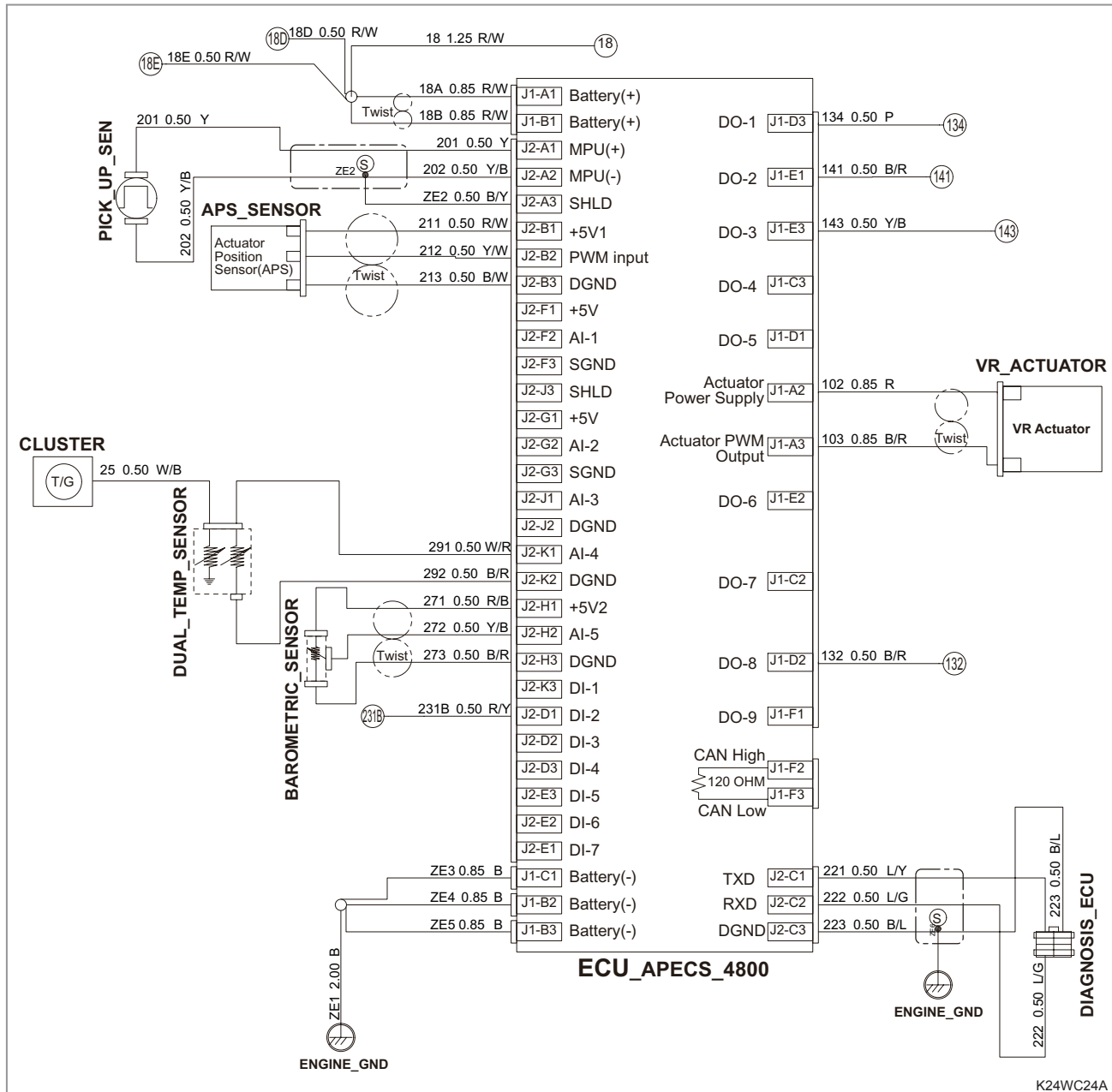

The ECU uses 12 V and 5 V. The ECU terminal using 12 V is marked with J1 while the ECU terminal using 5 V is marked with J2.

1. Input power (0.85 R/W)

The ECU receives 12 V through two terminals on the top left section shown in the circuit diagram. As it uses two identical input power wirings, their resistance is reduced.

2. Pick-up sensor

There are pick-up sensor wirings below the power lines as shown in the circuit diagram. The wiring 0.50 Y is to supply output voltage (5 V) to the pick-up sensor while one of the wirings 0.50 Y/B is the negative connecting wiring for the pick-up sensor. The other wiring 0.50 R/Y is the shield terminal connecting line to prevent any noise.

- SAFETY FIRST
- GENERAL
- ENGINE
- CVT
- TRANSMISSION
- CHASSIS
- REAR AXLE
- BRAKE
- FRONT AXLE
- STEERING
- HYDRAULIC
- ELECTRIC**
- INDEX

SAFETY FIRST

3. APS (Actuator Position Sensor)

The APS is a position control sensor located in the governor actuator and its terminals are located right below the pick-up sensor in the upper left section of the ECU circuit diagram. The wiring 0.50 R/W supplies 5 V to the APS and the wiring 0.50 Y/W is the analog input wiring to detect a position signal while the wiring 0.50 B/W is the negative wiring for the APS.

GENERAL

ENGINE

4. Water temperature sensor

The water temperature sensor terminals are located in the middle left section of the ECU circuit diagram. This sensor detects the coolant temperature and supplies this information to the ECU. The wiring 0.50 W/R supplies 5 V to the sensor while the wiring 0.50 B/R is the negative wiring for the sensor.

CVT

TRANSMISSION

5. Barometric pressure sensor

The barometric pressure sensor terminals are located in the middle left section of the ECU circuit diagram. This sensor supplies barometric pressure information to the ECU. The wiring 0.50 R/B supplies 5 V to the sensor while one of the wirings 0.50 Y/B G/W is the analog signal wiring to detect the barometric pressure and send this information to the ECU. The other wiring 0.50 B/R is the negative wiring for the sensor.

CHASSIS

6. Engine start signal input (231B, 0.50 R/Y)

This terminal is located in the lower left section of the ECU circuit diagram. It is to detect the start signal from the ignition switch (engine start signal) and this signal is used to determine the timing of preheat duration control.

REAR AXLE

BRAKE

7. ECU ground (0.85 B)

There are three ground wirings in the left bottom section of the ECU circuit diagram. Using three wirings is to reduce their resistance.

FRONT AXLE

STEERING

8. Check lamp (134, 0.50 P)

This terminal is located in the right top section of the ECU circuit diagram and it is connected to the display unit and this sends the signal to the check lamp on the combi-meter. If any faulty condition related to the governor control is occurred by the ECU, the negative wiring of the combi-meter cluster check lamp is connected to turn on the lamp.

HYDRAULIC

ELECTRIC

9. Preheat indicator (141, 0.50 B/R)

This terminal is located in the right top section of the ECU circuit diagram and it is connected to the display unit and this sends the signal to the preheat indicator on the combi-meter cluster. When the preheat operation is activated, the negative wiring is connected to turn on the preheat indicator.

INDEX

10. Blow relay (143, 0.50 Y/B)

This terminal is located right below the preheat indicator in the right top section of the ECU circuit diagram. The blow-motor is activated while the wiring 0.50 Y/B negative wiring for the blow relay.

11. VR actuator

This terminal is located in the middle right section of the ECU circuit diagram to control the actuator in order to control the fuel injection amount according to the barometric pressure information. The wiring 0.85 R supplies 12 V to the VR actuator while the wiring 0.85 B/R is the negative wiring for the actuator.

12. Preheat relay (132 0.50 B/R)

This terminal is located in the right bottom section of the ECU circuit diagram and it is connected to the pre-heat relay signal wiring. When the preheat operation is activated, the negative relay signal wiring is connected to operate the preheat relay.

13. TXD, RXD and DGND

These are located in the right bottom section of the ECU circuit diagram and these terminals are to perform diagnosis and program uploading through the interface with the diagnostic tool and laptop computer.

SAFETY FIRST

GENERAL

ENGINE

CVT

TRANSMISSION

CHASSIS

REAR AXLE

BRAKE

FRONT AXLE

STEERING

HYDRAULIC

ELECTRIC

INDEX

5. ELECTRICAL COMPONENTS

5.1 DISPLAY UNIT



The display unit is installed to the right side of the main frame under the passenger seat.

FUNCTION

1. Automatic preheat control:

When the coolant temperature is below 30°C (86° F), it operates the preheat relay to control the preheat operation as well as the preheat indicator on the instrument cluster. When the ignition switch is turned to the “ON” position, the preheat indicator on the instrument cluster comes on 8 seconds and the preheat relay is operated for up to 15 seconds to preheat the engine. The preheat operation is completed when the ignition switch is turned to the “ST” position and then released. Then, immediately, the post-heating operation is performed for 15 seconds. Therefore, the preheat time can be less than 15 seconds on occasion while the post-heating time is always 15 seconds.

2. Preheat system protection:

If the voltage becomes over 16 V, the preheat and post-heating operations are stopped to protect the preheat system.

3. Manual preheating:

When the ignition switch is turned to the “HEAT (GLOW)” position, between the “ON” and “ST” positions, and held in that position, the display unit operates the preheat relay and preheat indicator on the instrument cluster to heat the engine manually.

4. Stop solenoid pull-coil operation:

When the ignition switch is turned to the “ON” position to start the engine, the display unit operates the pull coil (32 A) for 1 second to pull the stop solenoid. As the stop solenoid is pulled, the injection pump rack in the engine is moved from the stop position to the engine starting position. Once the stop solenoid is pulled, it is held in the fuel supply status by the hold coil (0.77 A) which is powered directly by the ignition switch.

5. Cooling fan operation:

When the coolant temperature sensor detects the coolant temperature over 80 degrees, the cooling fan relay is operated to operate the cooling fan. When the coolant temperature drops below 75 degrees, the relay is stopped. The 5-degree difference between the activation and deactivation temperatures is set to protect the cooling fan from turning “ON” and “OFF” too frequently.

6. Vehicle speed detecting :

The vehicle speed sensor detects the RPM of the transmission drive gear and converts the signal to the voltage to operate the speedometer on the instrument panel.

5.1.1 EXTERNAL WIRING DIAGRAM FOR DISPLAY UNIT

US

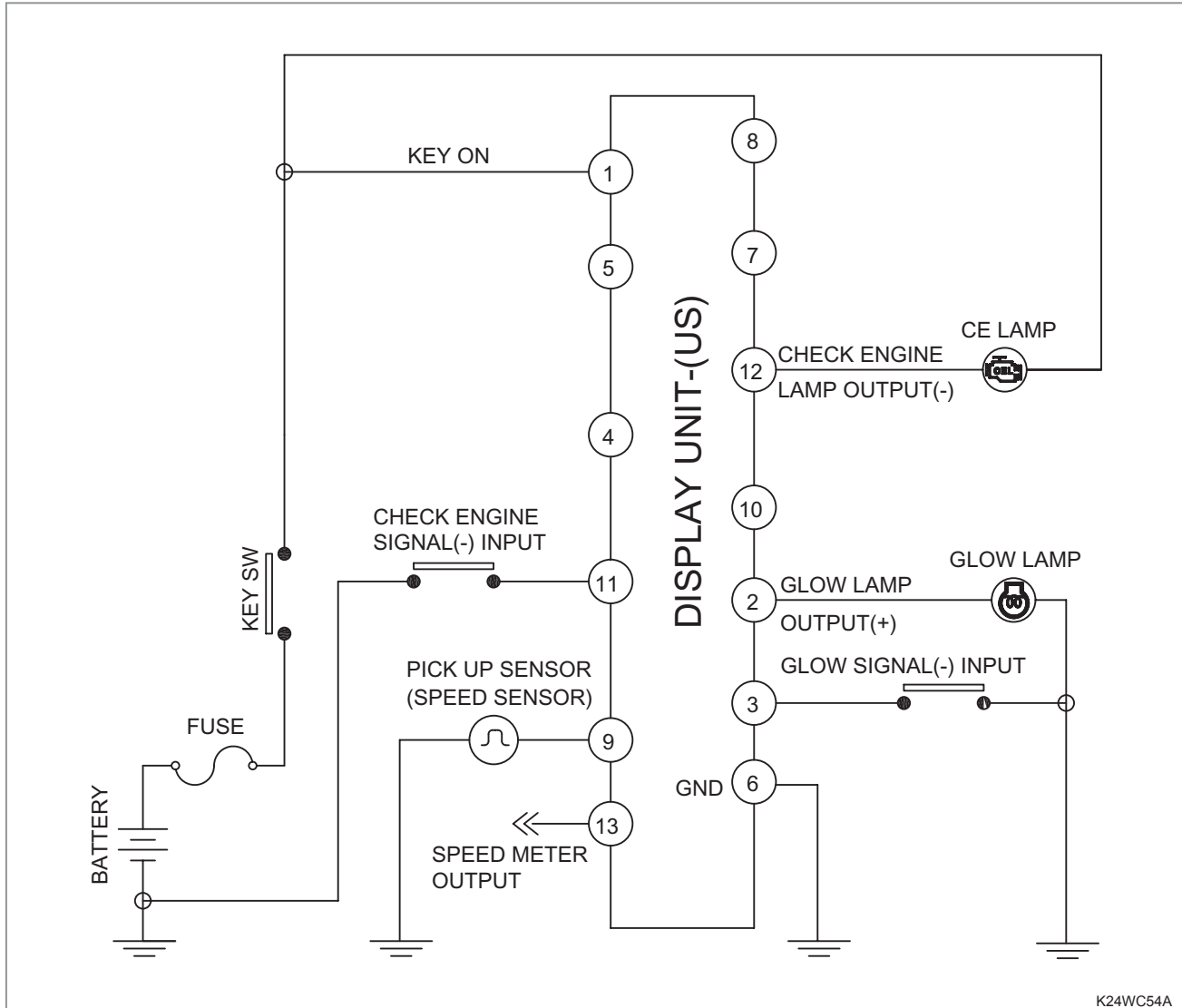

DISPLAY UNIT CONNECTOR DESCRIPTION

6	5	4	X	3	2	1
13	12	11	10	9	8	7

No.	Signal
1	KEY ON +12V
2	GLOW LAMP OUTPUT(+)
3	GLOW SIGNAL(-) INPUT
6	GND
9	PICK UP SENSOR
11	CE SIGNAL(-) INPUT
12	CE LAMP OUTPUT(-)
13	SPEED METER OUTPUT

- SAFETY FIRST
- GENERAL
- ENGINE
- CVT
- TRANSMISSION
- CHASSIS
- REAR AXLE
- BRAKE
- FRONT AXLE
- STEERING
- HYDRAULIC
- ELECTRIC**
- INDEX

EU

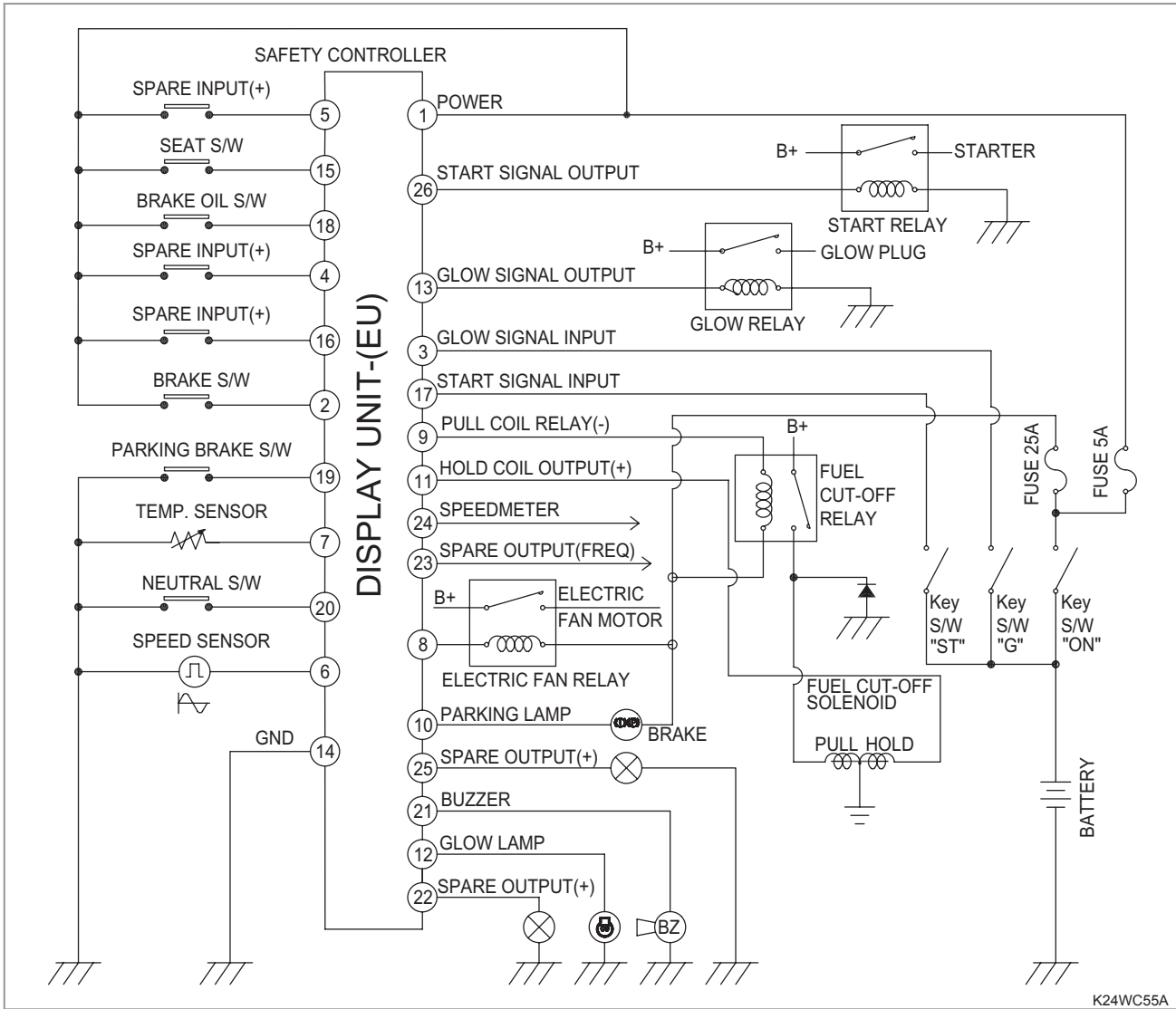

K24WC55A

DISPLAY UNIT CONNECTOR DESCRIPTION

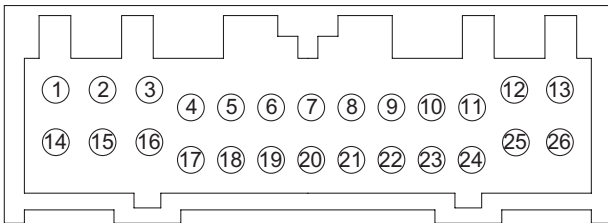

No.	Signal
1	KEY ON +12V
2	BRAKE S/W(+)
3	GLOW SIGNAL INPUT(+)
4	SPARE INPUT(+)
5	SPARE INPUT(+)
6	SPEED SENSOR INPUT
7	TEMP SENSOR
8	ELECTRIC FAN RELAY(-)
9	PULL COIL RELAY(-)
10	PARKING LAMP(-)

No.	Signal
11	HOLD COIL OUTPUT(+)
12	GLOW LAMP(+)
13	GLOW SIGNAL OUTPUT(+)
14	GND
15	SEAT S/W(+)
16	SPARE INPUT(+)
17	START SIGNAL INPUT(+)
18	BRAKE OIL SW(+)
19	PARKING BRAKE S/W(-)
20	NEUTRAL S/W(-)
21	BUZZER(+)
22	SPARE OUTPUT(+)
23	SPARE OUTPUT(Freq)
24	SPEEDMETER
25	SPARE OUTPUT(+)
26	START SIGNAL OUTPUT(+)

AU

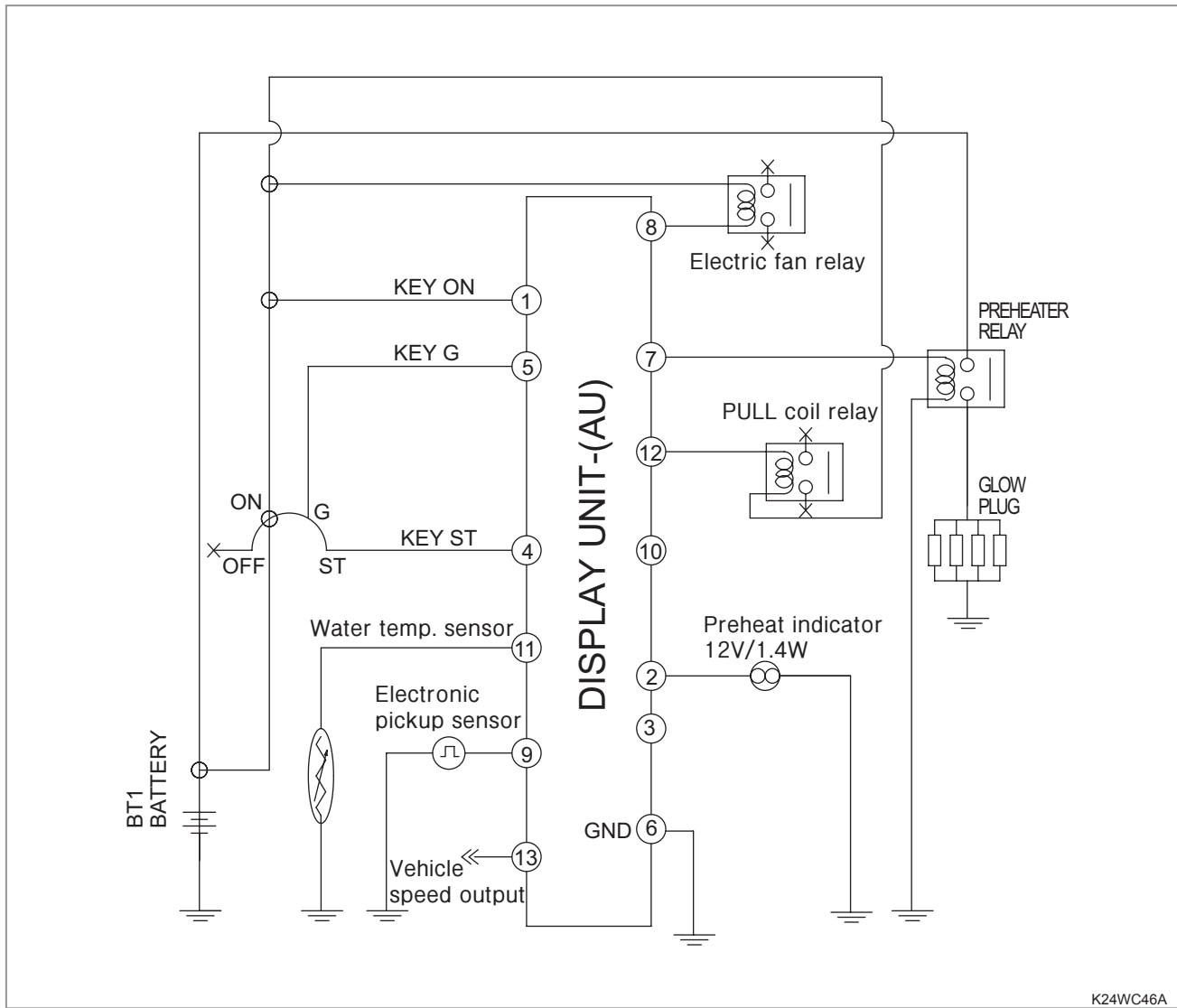

K24WC46A

DISPLAY UNIT CONNECTOR DESCRIPTION

6	5	4	X	3	2	1
13	12	11	10	9	8	7

No.	Signal
1	Key on + 12V
2	Preheat lamp output
4	Key switch ST input
5	Manual preheat signal input
6	GND
7	Preheat relay output
8	Fan motor output
9	Electronic pickup signal from ground speed
11	Coolant temperature sensor signal input
12	1 sec. output for pull coil
13	Speed signal output

- SAFETY FIRST
- GENERAL
- ENGINE
- CVT
- TRANSMISSION
- CHASSIS
- REAR AXLE
- BRAKE
- FRONT AXLE
- STEERING
- HYDRAULIC
- ELECTRIC**
- INDEX

5.2 COOLING FAN MOTOR

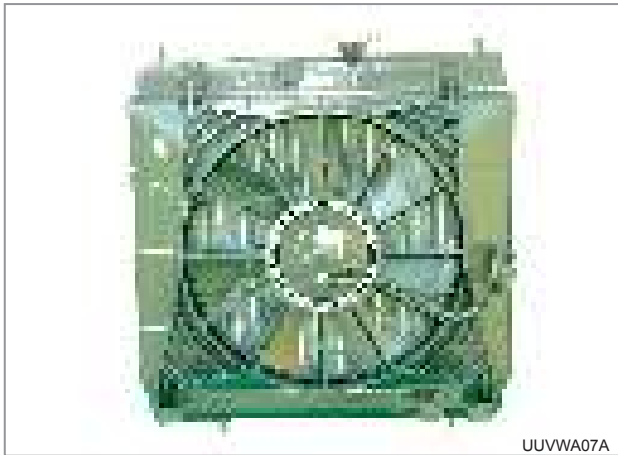

UUVWA07A

The cooling fan motor is installed on the back of the radiator under the hood.

MOTOR SPECIFICATIONS

Power	100W ± 10% (Max)
Rated speed	2060 rpm ± 10%
Rated voltage	DC 12V
Rated current	5 ~ 10A
Rotating direction	Counterclockwise (seen from front)
Free play in motor shaft direction	0.1 ~ 0.3 mm

OPERATION

- The cooling fan motor is operated and stopped according to the preset coolant temperature.

FAN MOTOR operated	Coolant temperature over 80°C (176°F)
FAN MOTOR stopped	Coolant temperature below 75°C (167°F)

FAN MOTOR TEST

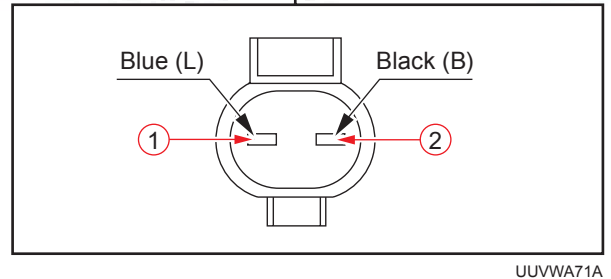

UUVWA71A

- Turn the ignition switch to the "OFF" position and disconnect the electric motor connector.
- Connect the terminal (1) to the positive battery terminal and the terminal (2) to the negative battery terminal using a jump leads.
- If the fan motor does not operate, replace it with a new one.

REMOVAL

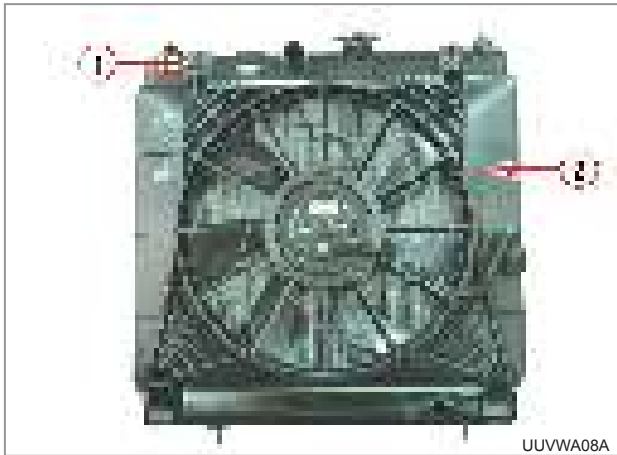

1. Unscrew the radiator cover mounting bolts (1) (M6, 2 EA) using the 10 mm socket wrench to remove the cover assembly (2).

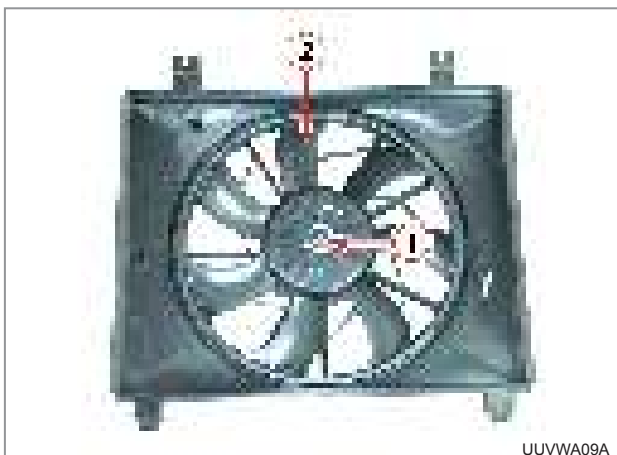

2. Remove the clip (1) from the cooling fan side. Then, remove the cooling fan (2) by pulling it up.

3. Turn the connector (1) to disconnect it. Then, unscrew the cooling fan motor mounting screws (2) to remove the cooling fan motor (3).

SAFETY FIRST

GENERAL

ENGINE

CVT

TRANSMISSION

CHASSIS

REAR AXLE

BRAKE

FRONT AXLE

STEERING

HYDRAULIC

ELECTRIC

INDEX

SAFETY FIRST

GENERAL

ENGINE

CVT

TRANSMISSION

CHASSIS

REAR AXLE

BRAKE

FRONT AXLE

STEERING

HYDRAULIC

ELECTRIC

INDEX

5.3 BULB REPLACEMENT

5.3.1 HEADLAMP



1. Remove the head lamp rear cap (1) by turning it.

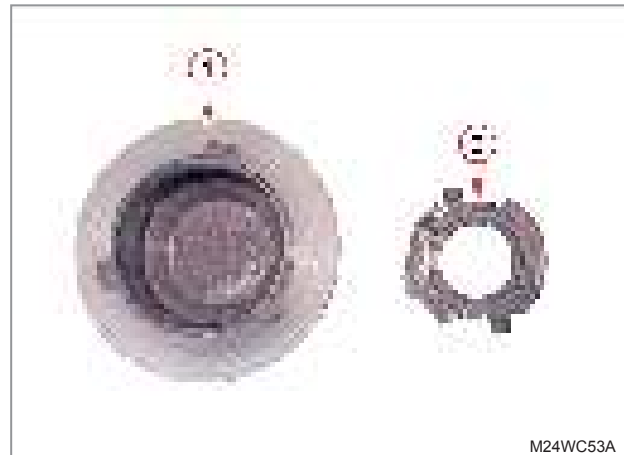

2. Pull out the connector (2).

3. Remove the retaining plate (3) of the bulb by turning it.



4. Remove the bulb (4) and replace the bulb with a new one if necessary
- Head lamp bulb specification : 12V 35W/35W

5.3.2 REAR COMBINATION LAMP

K9 2400 SW(GW)

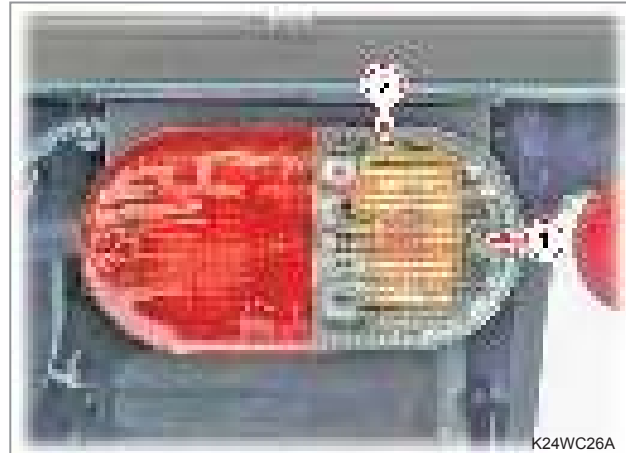

1. Unscrew the combination lamp lens mounting screws (1) and pull the lens (2) to remove it.



2. Remove the bulb (3), (4) by pressing and turning it. And replace the bulb with a new one if necessary.
- Bulb specification :
Brake lamp (3) - 12V 21W
Turn signal & position lamp (4) - 12V 21W/5W

SAFETY FIRST

GENERAL

ENGINE

CVT

TRANSMISSION

CHASSIS

REAR AXLE

BRAKE

FRONT AXLE

STEERING

HYDRAULIC

ELECTRIC

INDEX

SAFETY FIRST

GENERAL

ENGINE

CVT

TRANSMISSION

CHASSIS

REAR AXLE

BRAKE

FRONT AXLE

STEERING

HYDRAULIC

ELECTRIC

INDEX

K9 2400D - AU, K9 2400 -EU

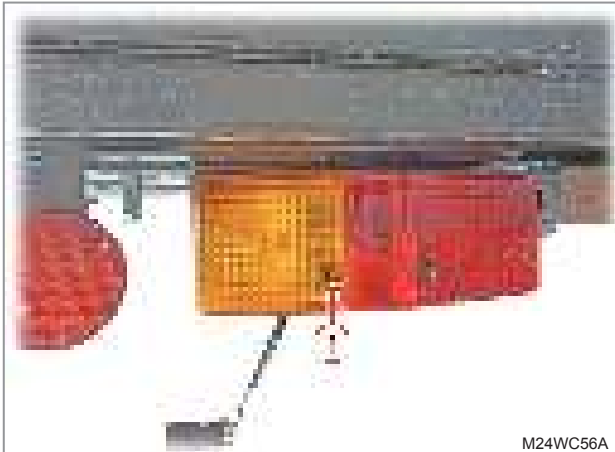

M24WC56A

1. Unscrew the combination lamp lens mounting screws (1) on the rear of the tractor.



M24WC57A

2. Press and turn each bulb of the brake lamp (2), turn signal lamp (3) and tail lamp (4) to remove it.
3. Replace the bulb with a new one if necessary
 - Bulb specification :
 - Brake lamp & Turn signal lamp : 12V 21W
 - Tail lamp : 12V 10W

5.4 SLOW-BLOW FUSE



(1) Main fuse (2) Ignition fuse

The slow-blow fuse is attached on the frame under the seat.

Capacity : 80A

If the slow-blow fuse is blown, all electric systems in the vehicle stop their operation.

If any electric system does not operate while the battery status good, the slow-blow fuse should be checked.

If the fuse is blown repeatedly, it is probable that B+ line (battery power) has a short circuit to body.

5.5 GLOW PLUG



The glow plug is installed in the engine cylinder head.

The glow plugs are used to warm the air in the combustion chamber before the engine is started.

- Current: Max. 20 A of current flows through the glow plug in 4 seconds after voltage is engaged. The glow plug temperature rises up to 800° C (1,472°F) in 4 seconds.

- Continuity test:



Disconnect the leads and measure the resistance between the terminal and body. If the measurement is over the specification (approx. 0.43 Ω), replace the glow plug.

- Circuit test:

SAFETY FIRST
GENERAL
ENGINE
CVT
TRANSMISSION
CHASSIS
REAR AXLE
BRAKE
FRONT AXLE
STEERING
HYDRAULIC
ELECTRIC
INDEX

- SAFETY FIRST
- GENERAL
- ENGINE
- CVT
- TRANSMISSION
- CHASSIS
- REAR AXLE
- BRAKE
- FRONT AXLE
- STEERING
- HYDRAULIC
- ELECTRIC**
- INDEX



UUVWA84A

Disconnect the glow plug connector and connect the positive test lead to the wiring connector terminal (red with black stripe) and negative test lead to the body. Check that the voltage is 12 V when the ignition switch is in the "HEAT" position (manual preheating condition).

5.6 ENGINE STOP SOLENOID



UUVWA20A

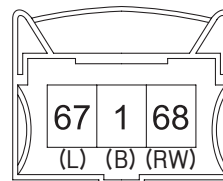

Wiring connector

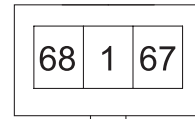

Solenoid connector

UUVWA89A

The engine stop solenoid is installed on the engine gear case.

The resistance of the engine stop solenoid should be measured when the wiring connector is disconnected.



UUVWA85A

Tester selector	Tester's measuring point		Remarks	Result
	Red lead	Black lead		
Resistance	Connector ⑥8	Connector ① (GND)	Hold coil	Approx. 13.8 Ω
	Connector ⑥7	Connector ① (GND)	Pull coil	Approx. 0.4 Ω

- The voltage should be measured when turning the key switch to ON position when the wiring connector is installed.



Tester selector	Tester's measuring point		Remarks	Result
	Red lead	Black lead		
VDC	Connector ⑥⑧ (RW)	Connector ① (GND) (B)	Key switch ON	DC 12V
	Connector ⑥⑦ (L)	Connector ① (GND) (B)	Key switch OFF → ON : voltage generated for 1 second	DC 12V

5.7 PARKING BRAKE SWITCH



The parking brake switch is installed to the front of the parking brake lever on the left side from the steering wheel.

- N.O (Normally open) type:
It is normally open (OFF) but it is closed (ON) when contact point is pressed.

CONTINUITY TEST

Disconnect the parking brake switch connector and measure the resistance between the switch terminal and chassis (ground).

Measure the resistance separately with the parking brake lever applied and released.

Tester selector	Tester's measuring point		Remarks	Result
	Red lead	Black lead		
Continuity	Switch terminal	Body (GND)	Parking brake released (switch Released)	No continuity
			Parking brake applied (switch pressed)	Continuity (beeping)

- SAFETY FIRST
- GENERAL
- ENGINE
- CVT
- TRANSMISSION
- CHASSIS
- REAR AXLE
- BRAKE
- FRONT AXLE
- STEERING
- HYDRAULIC
- ELECTRIC**
- INDEX

SAFETY FIRST

GENERAL

ENGINE

CVT

TRANSMISSION

CHASSIS

REAR AXLE

BRAKE

FRONT AXLE

STEERING

HYDRAULIC

ELECTRIC

INDEX

5.8 NEUTRAL SWITCH

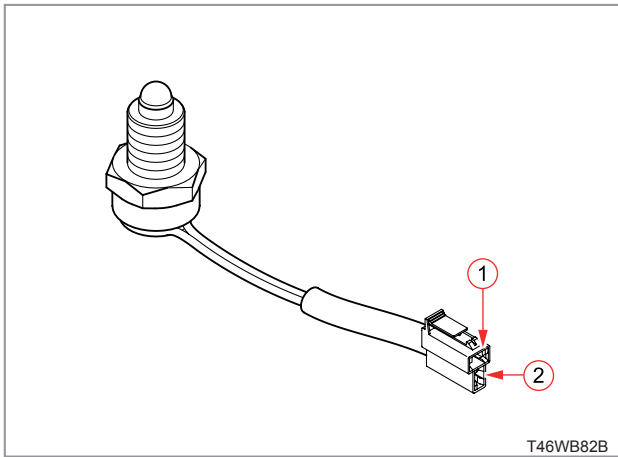
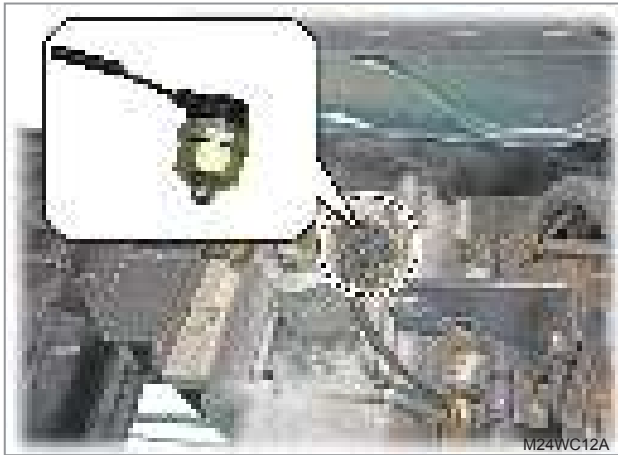

The neutral switch is installed on the transmission case.

This switch is installed to prevent the engine from starting when the shift lever is not in the neutral position.

1. N.C (Normal Closed) Type
2. It means that it is normally closed (ON), but it is open (OFF) when the contact point is pressed.

CONTINUITY TEST



Range	Tester's measuring point		Remarks	Result
	Red lead	Black lead		
Continuity	No. 1 connector	No. 2 connector	Switch Released	Continuity (beeping)
	No. 1 connector	No. 2 connector	Switch Pushed	No continuity

5.9 ENGINE OIL PRESSURE SWITCH



The engine oil pressure switch is installed on the cylinder block.

If the engine oil pressure drops below $0.5 \pm 0.1 \text{ kg/cm}^2$ (7 psi \pm 1.4 psi), the circuit in the sensor closed to send a signal to the oil pressure warning lamp on the instrument panel.



Disconnect the engine oil pressure switch connector and disassemble the engine oil pressure switch to measure its resistance.

Tester selector	Tester's measuring point		Remarks	Result
	Red lead	Black lead		
Resistance	Oil switch (+)	Body (GND)	No pressure applied	Continuity (0.5 Ω)

5.10 COOLANT TEMPERATURE SENSOR



The coolant temperature sensor is installed on the coolant flange.

It is not recommended to measure the resistance of temperature sensor separately. Measure the V(DC) on the display unit while the key is "ON" with the wire connected.

TEST



Disassemble the coolant temperature sensor and soak it in water in a test container. Prepare the water with its temperature according to the value in the table below, Make sure that only the tip of the sensor is soaked in water.

Temp. ($^{\circ}\text{C}$)	15 $^{\circ}$	30 $^{\circ}$	60 $^{\circ}$	Remarks
To display unit input (VDC)	Approx. 3.2 V	Approx. 2.5 V	Approx. 1.4 V	Preheating or fan operation
To instrument cluster input (VDC)	Approx. 10 V	Approx. 10 V	Approx. 10 V	Temp. gauge operation

- SAFETY FIRST
- GENERAL
- ENGINE
- CVT
- TRANSMISSION
- CHASSIS
- REAR AXLE
- BRAKE
- FRONT AXLE
- STEERING
- HYDRAULIC
- ELECTRIC**
- INDEX

- SAFETY FIRST
- GENERAL
- ENGINE
- CVT
- TRANSMISSION
- CHASSIS
- REAR AXLE
- BRAKE
- FRONT AXLE
- STEERING
- HYDRAULIC
- ELECTRIC**
- INDEX

Connect the positive test lead to the pin No. G25 and the negative test lead to the pin No. G601 of the instrument panel wire connector and measure the VDC with the ignition switch in the "ON" position.

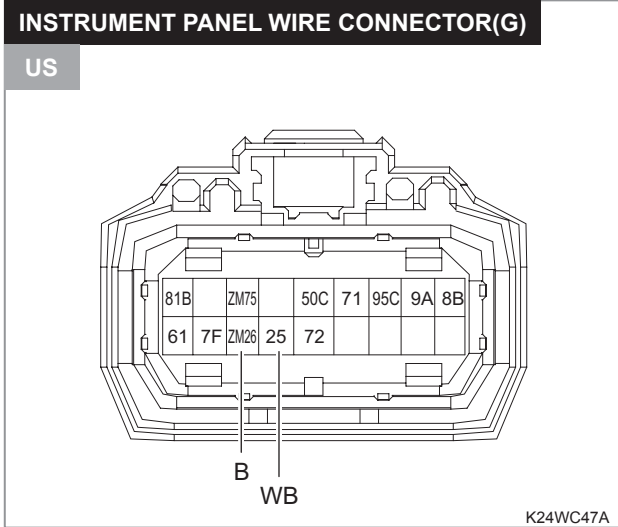

- 25: Temp. gauge sig.
- ZM26: GND

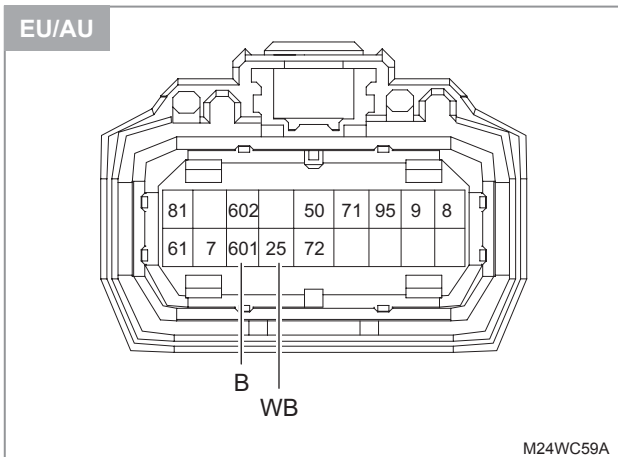

- 25: Temp. sensor
- 601: GND

Connect the positive test lead to the pin No. 23 and the negative test lead to the pin No. 599 of the display unit wire connector and measure the VDC with the ignition switch in the "ON" position.

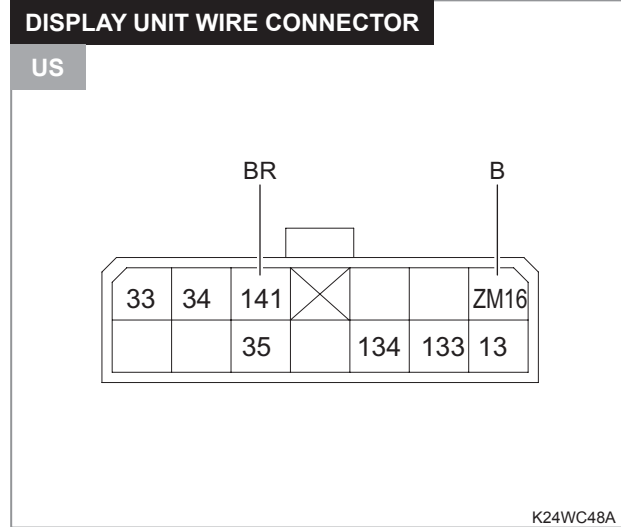

- 141: Display unit glow input
- ZM16: GND

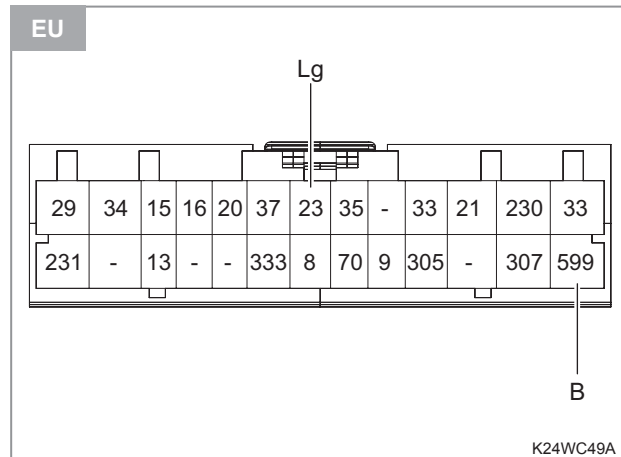

- 23: Temp. switch (Glow)
- 599: GND

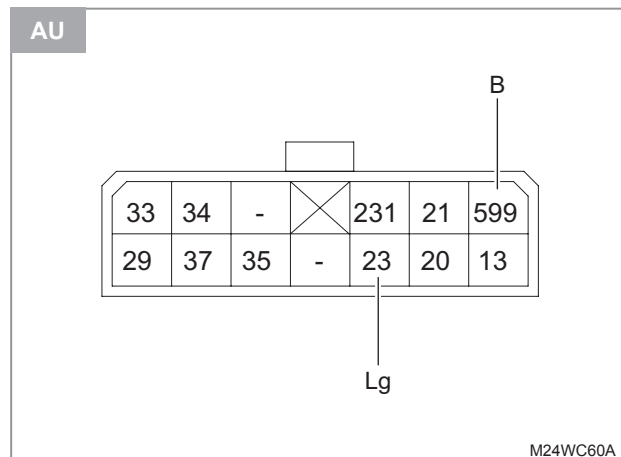

- 23: Temp. switch (Glow)
- 599: GND

REMARK

- The temperature sensor is a dual sensor and it has two purposes.

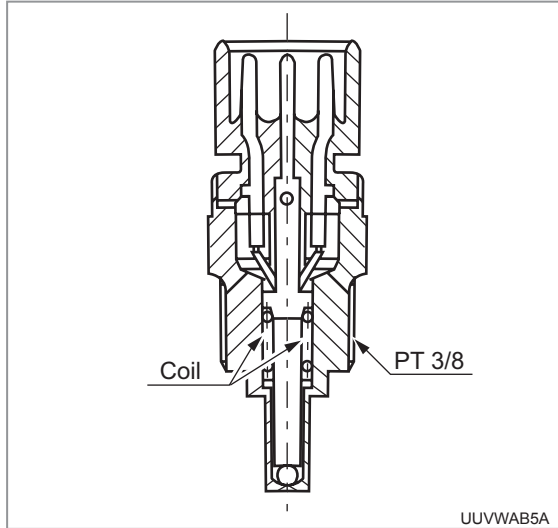

The coil with low resistance in the sensor is for temp. gauge. Therefore the voltage value does not change a lot as shown in the table above. However, the other coil with high resistance in the sensor is for supplying the signal to display unit so that it can determine when the fan motor or preheat relay should be activated. Therefore a voltages measurement is recommended for preheating and fan motor sensor testing as shown in the table above. A resistance measurement is recommended for temp. gauge check as below table.

1. SENSOR FOR TEMP. GAUGE

- Resistance

Temp. (°C)	60	85	110	125
Resistance (Ω)	(125)	48.4 ± 5.8	24 ± $\frac{2.2}{1.9}$	(15.2)

- () : Reference value

2. SENSOR FOR PRE-HEATING AND FAN MOTOR.

- Resistance

Temp. (°C)	- 40	- 20	0	20	40
Resistance (kΩ)	(48.14)	15.48 ± 1.35	(5.790)	2.45 ± 0.14	(1.148)
Temp. (°C)	60	80	100	110	120
Resistance (kΩ)	(0.5865)	(0.3222)	(0.1884)	0.1471 ± 0.002	(0.1163)

- () : Reference value

- SAFETY FIRST
- GENERAL
- ENGINE
- CVT
- TRANSMISSION
- CHASSIS
- REAR AXLE
- BRAKE
- FRONT AXLE
- STEERING
- HYDRAULIC
- ELECTRIC**
- INDEX

SAFETY FIRST

GENERAL

ENGINE

CVT

TRANSMISSION

CHASSIS

REAR AXLE

BRAKE

FRONT AXLE

STEERING

HYDRAULIC

ELECTRIC

INDEX

5.11 FUEL SENDER



Disconnect the fuel sender connector and disassemble the fuel sender to measure its resistance.

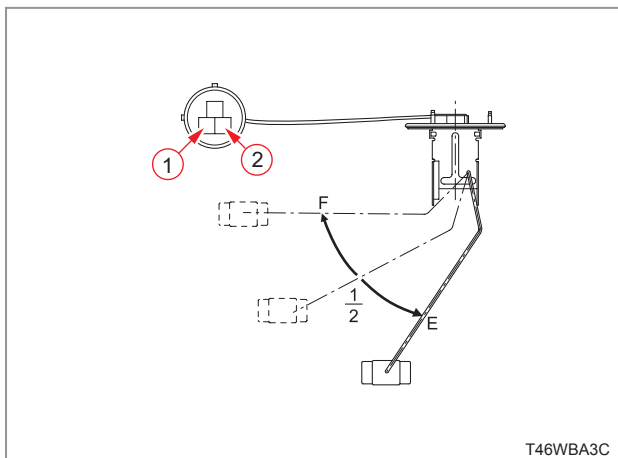

The fuel sender is installed on the top of the fuel tank.

The sender float moves with the fuel level in the fuel tank, changing resistance in the circuit of the fuel gauge.

Level	Full	1/2	Empty
Resistance (Ω)	2.5	(32.5)	110
Tolerance (Ω)	± 2	-	± 7

Tester selector	Tester's measuring point		Remarks	Result
	Red lead	Black lead		
Resistance	Connector ①	Connector ②	By fuel sender float position	See table above

5.12 ALTERNATOR



M24WC16A

There are some components, such as headlamp, start motor, engine stop solenoid and glow plugs, which need a lot of electricity. The alternator supplies power to such components and charges the battery which stores electricity for the vehicle.

Therefore, the alternator correlates with the battery and electric loads and it is an original source of electricity for the entire vehicle.

TEST

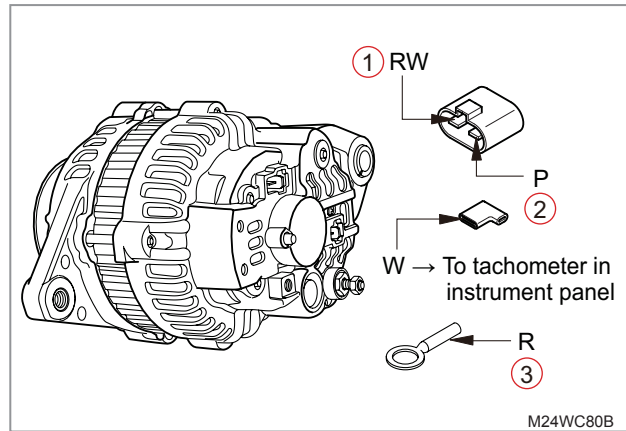

M24WC80B



UUVWA98A

Tester selector	Tester's measuring point		Operation	Result
	Red lead	Black lead		
DC Voltage	No. 3 (R)	Body (GND)	OFF	DC 12.4 V
			ON	DC 12.3 V
			RUN	DC 14.5 V
	No. 1 (RW)	Body (GND)	OFF	DC 0 V
			ON	DC 12.1 V
			RUN	DC 14.4 V
	No. 2 (P)	Body (GND)	OFF	DC 0 V
			ON	DC 1.9 V
			RUN	DC 14.6 V

- SAFETY FIRST
- GENERAL
- ENGINE
- CVT
- TRANSMISSION
- CHASSIS
- REAR AXLE
- BRAKE
- FRONT AXLE
- STEERING
- HYDRAULIC
- ELECTRIC**
- INDEX

● PERFORMANCE CURVE OF ALTERNATOR

As shown in the performance curve below, the alternator does not generate the power until its speed reaches 1,200 rpm.

This minimum revolution speed is called "Cut In Speed".

If the alternator's speed is below the cut in speed, the alternator does not generate the power and the charge warning lamp does not go off.

Also, the power performance changes as the output current (A) changes according to the coil's temperature (cold and hot). Therefore, the average curve for the cold and hot conditions is presented as guaranteed performance.

In general, the alternator's pulley ratio is determined to maximize the alternator power in the rated speed of the engine.

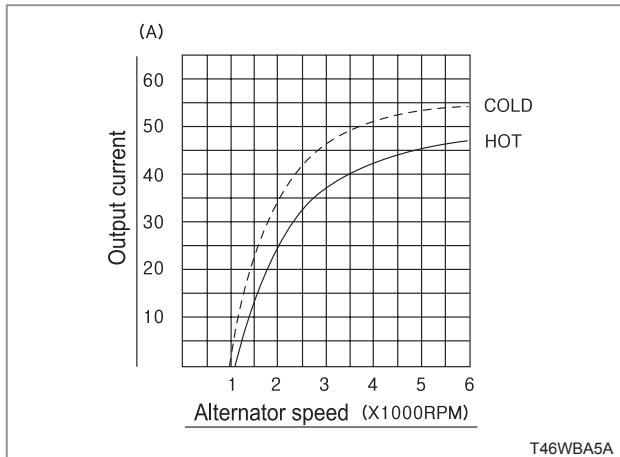

This engine's speed ratio between alternator pulley to crank shaft pulley is 2.16.

Therefore, the alternator pulley speed will be over 1800rpm while the engine is idling.

However, for the fast charge of battery run the engine at 1500rpm or faster.

* Maximum output ampere : 50A

5.13 SPEED SENSOR



The vehicle speed sensor is attached to the side of the transmission case.

It detects the turning speed of the 31 bevel gear and sends this information to the speedometer on the instrument cluster through the display unit.

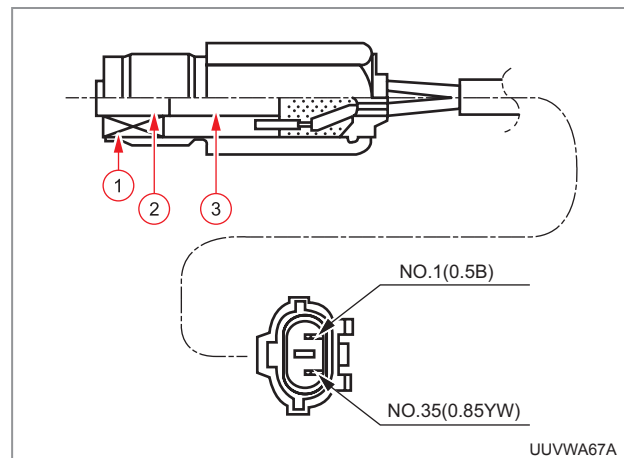

(1) COIL (2) CORE (3) MAGNET

As the 31 bevel gear rotates, the voltage waveform is generated in the coil in the vehicle speed sensor. Then, the waveform signal, which is proportional to the gear speed, is sent to the display unit which then converts this to the voltage and operates the speedometer on the instrument cluster.

SPECIFICATIONS

Resistance between terminals	2.2 ± 0.2 KΩ (at 15°C)
------------------------------	------------------------

TEST

1. Connect the positive test lead to the pin No. B 310 and the negative test lead to the pin No. B 600 of the instrument panel wire connector and measure the VDC. The measurement should be approx. 7 V at high ground speed and 0 V or approx. 14 V when the wheel is standing still.

INSTRUMENT PANEL WIRE CONNECTOR (B)

US

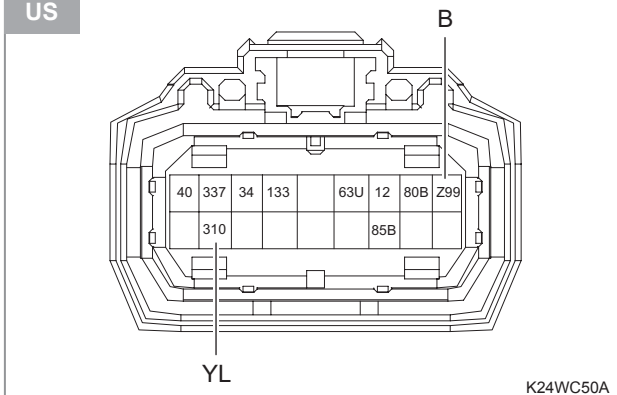

K24WC50A

- 310: Speedmeter sig.
- Z99: GND

EU/AU

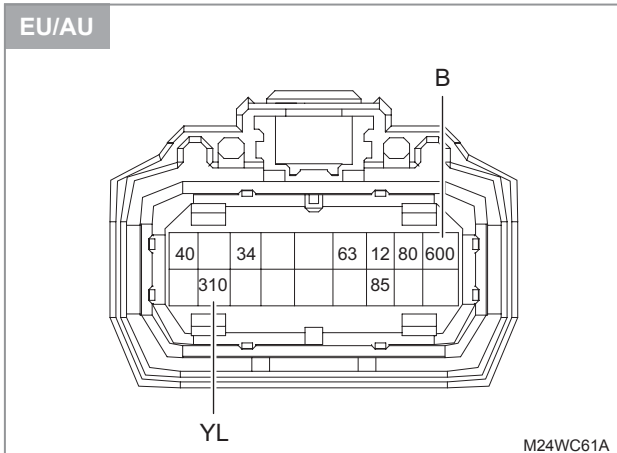

M24WC61A

- 310: Speed sensor input
- 600: GND

! IMPORTANT

- This test should be performed while the vehicle is supported by a stand, the four wheels are off ground and the shift lever is in the "H" position.

REMARK

SPEED SIGNAL OUTPUT FROM DISPLAY UNIT

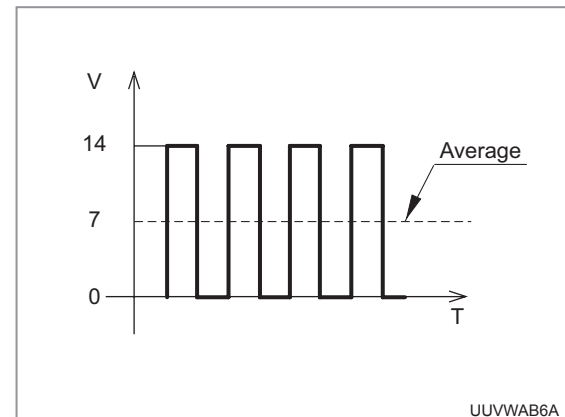

UUWVAB6A

- As the multi tester can not read exact voltage which is fluctuate with high frequency, it just shows average value(7V) as shown in the picture when the wheel is turning while it shows 0V or 14V when the wheel is stopped.
- The speed change can not be read by multi tester as the speedometer in the dash can read it according to the frequency(Hz) change.

SAFETY FIRST

GENERAL

ENGINE

CVT

TRANSMISSION

CHASSIS

REAR AXLE

BRAKE

FRONT AXLE

STEERING

HYDRAULIC

ELECTRIC

INDEX

- SAFETY FIRST
- GENERAL
- ENGINE
- CVT
- TRANSMISSION
- CHASSIS
- REAR AXLE
- BRAKE
- FRONT AXLE
- STEERING
- HYDRAULIC
- ELECTRIC**
- INDEX

2. Connect the positive test lead to the pin No. 13 and the negative test lead to the pin No. 599 of the display unit wire connector and measure the VDC. The measurement should be approx. 0 V at full speed and at idle.

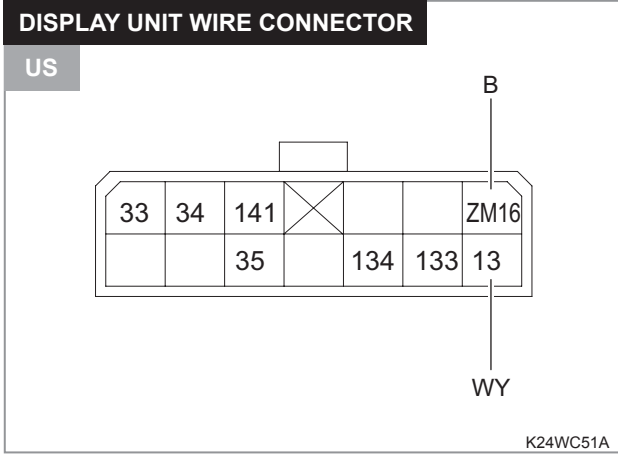

- 13: Speedmeter sig.
- ZM16: GND

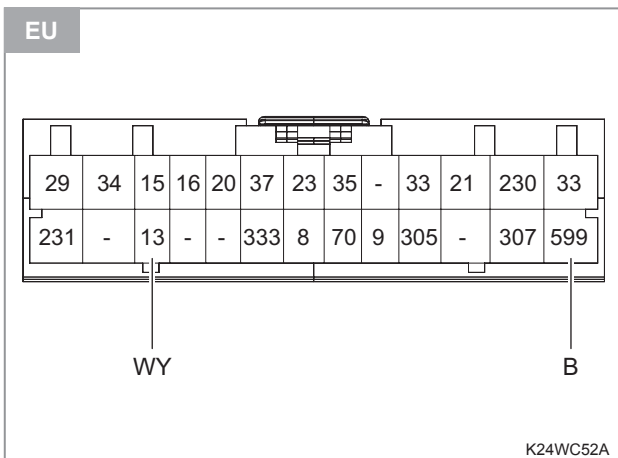

- 13: Speed sensor output
- 599: GND

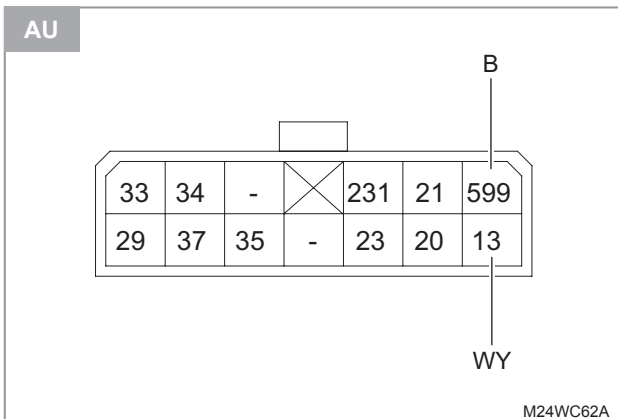

- 13: Speed sensor output
- 599: GND

REMARK

SPEED SIGNAL OUTPUT FROM SPEED SENSOR

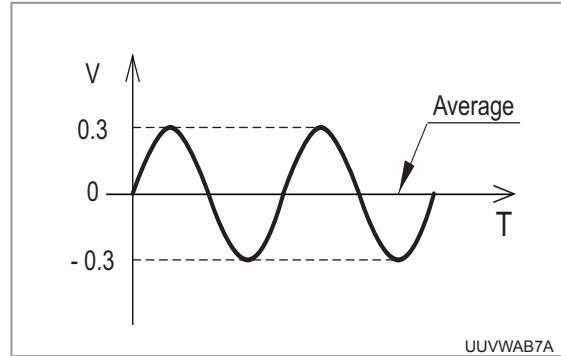

- The output voltage from speed sensor is shown in the graph above. However, it is hard to read with normal multi tester as its average is zero and its peak voltage capacity is small due to its curved top and bottom. Therefore, it is recommended to measure the display unit output voltage or instrument panel input signal. Because the display unit amplifys this input signal to 0 ~ 14V and modulates the sine curve to a square wave as shown in the former remark box.

5.14 KEY SWITCH



The key switch is installed on the right side of the steering wheel.

1. KEY SWITCH'S POSITION

1. OFF
 2. ACC
 3. ON
 4. HEAT(GL) : Manual preheat
 5. START
- The "START" position is spring loaded to return to the "ON" position.
 - The "HEAT(GL)" position is spring loaded to return to the "ON" position.

2. KEY SWITCH TEST



Disconnect the key switch from the wiring harness connector.

Use an ohmmeter (Ω) to test the switch.

- With the key in "OFF" position, the continuity will not exist between any of the terminals. (resistance : ∞)
 - With the key in "ACC" position, there will be continuity between the (AM) and (ACC) terminals. (resistance : 0Ω)
 - With the key in "ON" position, there will be continuity between the (AM), (ACC) and (M) terminals. (resistance : 0Ω)
 - With the key in "GL" position, there will be continuity between the (AM), (M) and (G) terminals. (resistance : 0Ω)
 - With the key in "ST" position, there will be continuity between the (AM), (M) and (ST) terminals. (resistance : 0Ω)
- ※ If the test results are not as outlined above, replace the key switch.

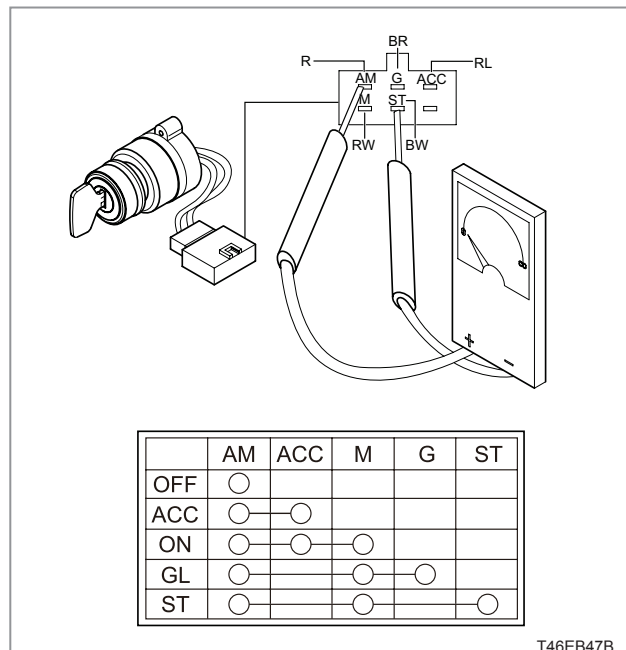

- SAFETY FIRST
- GENERAL
- ENGINE
- CVT
- TRANSMISSION
- CHASSIS
- REAR AXLE
- BRAKE
- FRONT AXLE
- STEERING
- HYDRAULIC
- ELECTRIC**
- INDEX

SAFETY FIRST

GENERAL

ENGINE

CVT

TRANSMISSION

CHASSIS

REAR AXLE

BRAKE

FRONT AXLE

STEERING

HYDRAULIC

ELECTRIC

INDEX

5.15 COMBINATION SWITCH



The combination switch is installed on the left side from the steering wheel on the main instrument panel.

Seven switch positions:

- OFF
- Position lamp
- Tail/Head lamp (low beam)
- Head lamp (high beam)
- Turn signal lamp (LH)
- Turn signal lamp (RH)
- Horn

FUNCTION

- Turning the lever forward once with the ignition switch in the "ON" position turns on the tail lamps.
- Turning the lever forward to the 2nd stop with the ignition switch in the "ON" position turns on the tail lamps and headlamps (low beam).
- Pulling the switch lever up with the headlamp illuminated turns on the high beam. Pulling the lever down turns on the low beam.
- The left turn signal lamp comes on when pulling the lever toward the seat. The right turn signal lamp comes on when pushing the lever toward the opposite side.
- Press the tip of the lever to sound the horn.

DIAGRAM FOR COMBINATION SWITCH CONNECTION

Combination switch connector side

TER. POS.	49	31	TER. POS.	30	57/58	56b	56a	TER. POS.	L	54D	54S
FREE			OFF					1	○—○		
PUSH	●—●		1	○—○	○—○			OFF			
			2	○—○		○—○		2	○—○		○—○

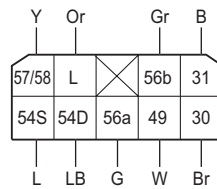

T85WB31A

TEST



A40WB07A

Range	Operation	Tester's measuring point		Result
		Red lead	Black lead	
Resistance	Moving lever to 1st position	Connector No. 30 (Br)	Connector No. 57/58 (Y)	Continuity
DC voltage		Connector No. 57/58 (Y)	Ground (B)	DC12 V
Resistance	Moving lever to 2nd position	Connector No. 30 (Br)	Connector No. 57/58 (Y)	Continuity
			Connector No. 56b (Gr)	Continuity
DC voltage		Connector No. 56b (Gr)	Ground (B)	DC11 V
Resistance	Operating headlamp switch for high beam	Connector No. 56a (G)	Connector No. 57/58 (Y)	Continuity
DC voltage			Connector No. 30 (Br)	DC11 V
Resistance	Pulling lever	Connector L (Or)	Connector No. 54S (L)	Continuity
DC voltage		Connector No. 54S (L)	Body ground (B)	DC8.7 V

- SAFETY FIRST
- GENERAL
- ENGINE
- CVT
- TRANSMISSION
- CHASSIS
- REAR AXLE
- BRAKE
- FRONT AXLE
- STEERING
- HYDRAULIC
- ELECTRIC**
- INDEX

- SAFETY FIRST
- GENERAL
- ENGINE
- CVT
- TRANSMISSION
- CHASSIS
- REAR AXLE
- BRAKE
- FRONT AXLE
- STEERING
- HYDRAULIC
- ELECTRIC**
- INDEX

Range	Operation	Tester's measuring point		Result
		Red lead	Black lead	
Resistance	Pushing lever	Connector L (Or)	Connector No. 54D (LB)	Continuity
DC voltage		Connector No. 54D (LB)	Body ground (B)	DC7.5 V
Resistance	Pushing tip of lever	Connector No. 49 (W)	Connector No. 31 (B)	Continuity

The voltage should be measured when the key switch is in the "ON" position.

When measuring the resistance with a tester, it is OK to switch the leads (red and black).

※ If the test results are not as outlined above, replace the combination switch.

5.16 FLASHER UNIT [K9 2400SW(GW) ONLY]



The flasher unit is attached to the main frame under the seat

The flasher unit flashes the turn signal lamp or emergency lamp when lamp is operated.

* When you press the hazard switch while the turn signal lamp is ON, the turn signal lamp (LH or RH) blinks faster.

CONNECTOR

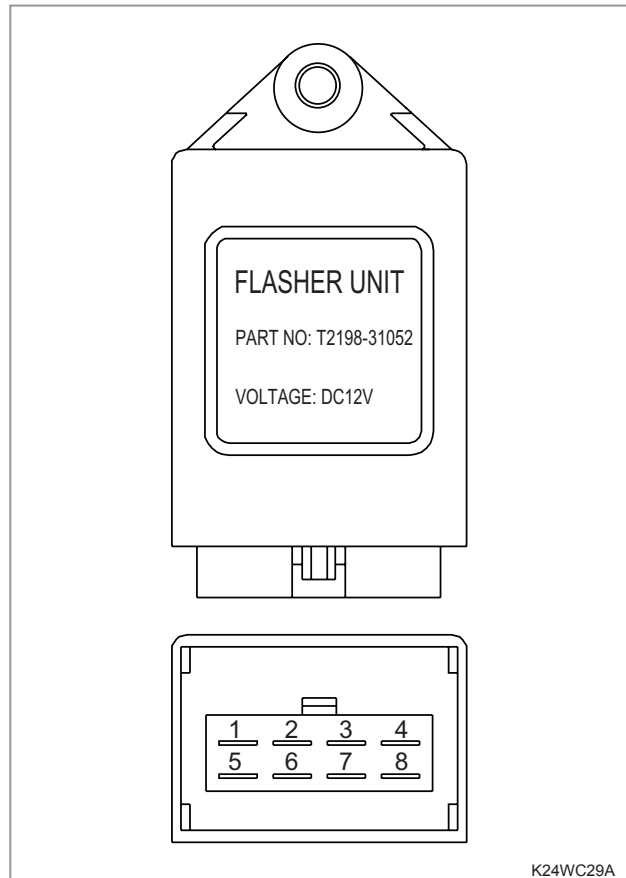

K24WC29A

CIRCUIT DIAGRAM

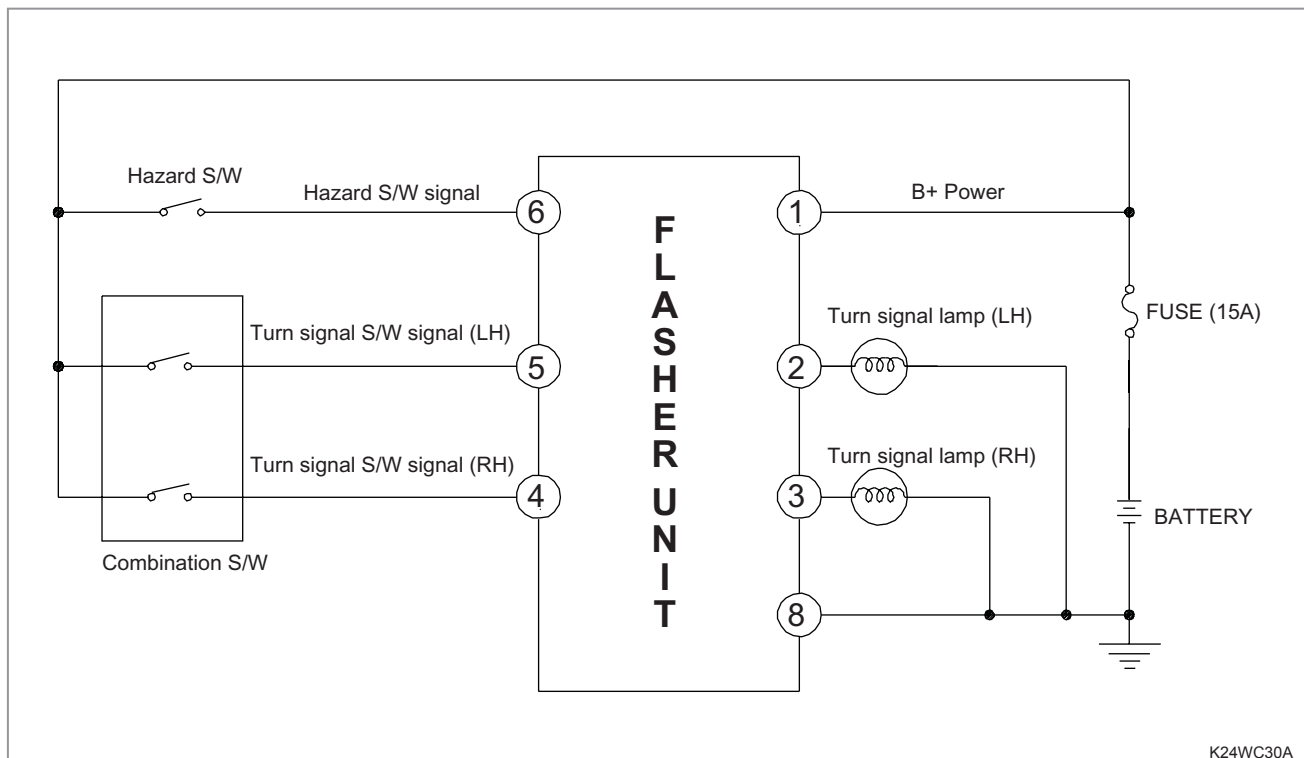

K24WC30A

SAFETY FIRST

GENERAL

ENGINE

CVT

TRANSMISSION

CHASSIS

REAR AXLE

BRAKE

FRONT AXLE

STEERING

HYDRAULIC

ELECTRIC

INDEX

5.17 POWER RELAY / GLOW RELAY



M24WC20A

(1) Power relay

(2) Glow relay

The power relay (1) and glow relay (2) are attached on the center of the main frame under the seat.

The glow relay operates the glow plug and power relay supplies power to the electric components such as wiper motor.

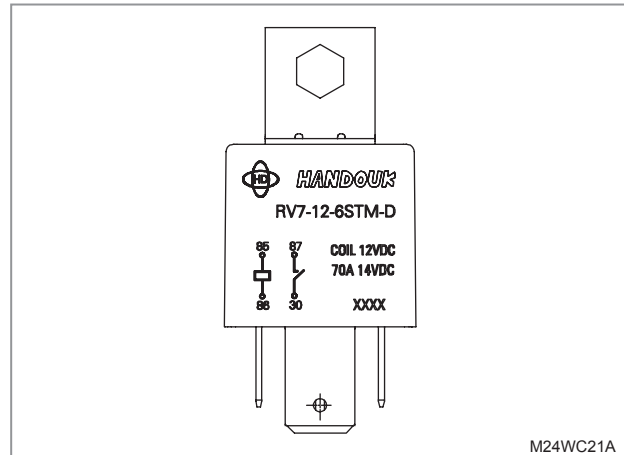

M24WC21A

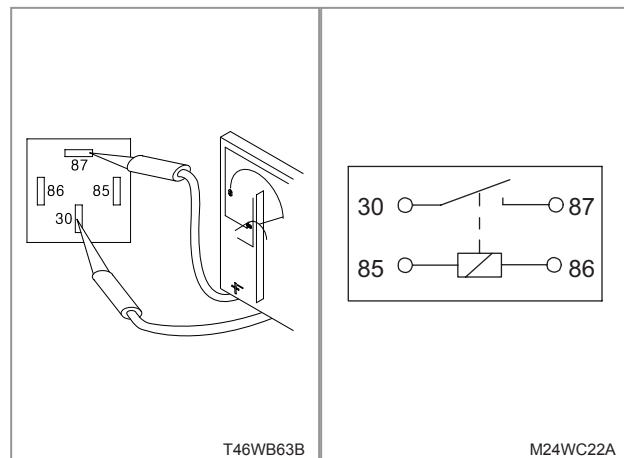

To perform the relay test, disconnect and remove the relay from the wiring.

Check the resistance and continuity within the resistance range (Ω) of a tester.

Numbers on the auxiliary relay terminals indicate corresponding coil and contact.

- Capacity: 13.5 V, 70 A

5.18 INSTRUMENT PANEL

COMPONENTS

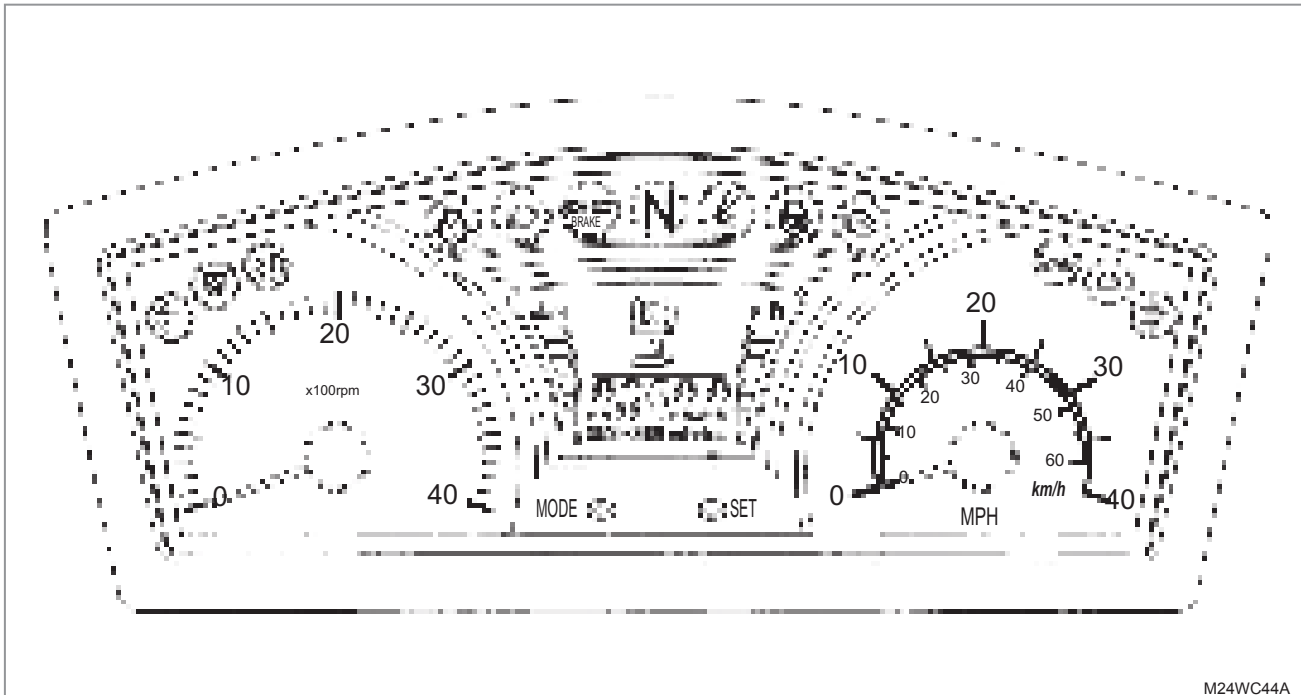

M24WC44A

CONNECTORS AND SYMBOLS

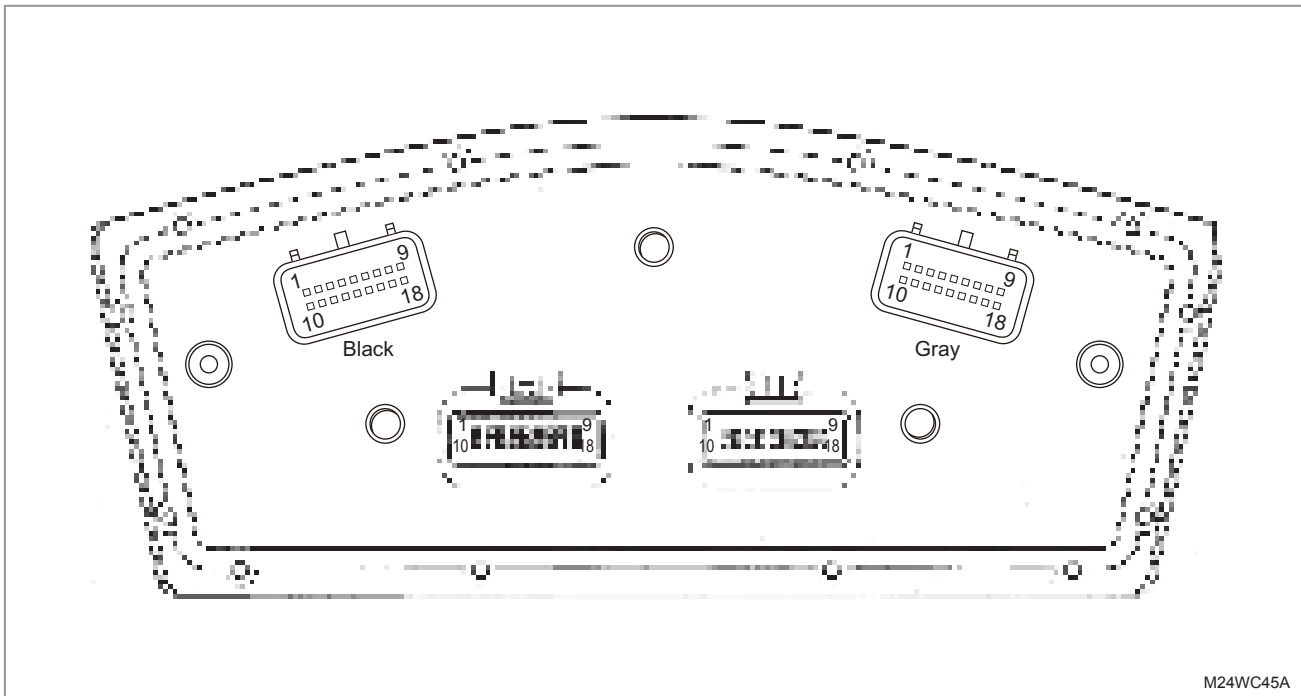

M24WC45A

- SAFETY FIRST
- GENERAL
- ENGINE
- CVT
- TRANSMISSION
- CHASSIS
- REAR AXLE
- BRAKE
- FRONT AXLE
- STEERING
- HYDRAULIC
- ELECTRIC**
- INDEX

- SAFETY FIRST
- GENERAL
- ENGINE
- CVT
- TRANSMISSION
- CHASSIS
- REAR AXLE
- BRAKE
- FRONT AXLE
- STEERING
- HYDRAULIC
- ELECTRIC**
- INDEX

No.	B1	B2	B3	B4	B5	B6	B7	B8	B9
Function	GND	Turn/R	CHARGE	Turn signal lamp		CHECK	GLOW	Seat belt warning	Engine speed
Condition		(+)	(-)	(+)		(-)	(+)	(-)	12V Wave form signal
Symbol									

No.	B10	B11	B12	B13	B14	B15	B16	B17	B18
Function		P - Gear	R - Gear	H - Gear	L - Gear			Vehicle speed signal	Vehicle mileage signal, power
Condition		(-)	(-)	(-)	(-)			Wave form signal	9V Electric components
Symbol		P	R	H	L				

No.	G1	G2	G3	G4	G5	G6	G7	G8	G9
Function	N - Gear	Parking brake	Headlamp	Engine oil pressure	Fog lamp		GND		Turn/L
Condition	(-)	(-)	(+)	(-)	(+)				(+)
Symbol	N								

No.	G10	G11	G12	G13	G14	G15	G16	G17	G18
Function		PTO	ECU error code		Fuel lever	Coolant temp.	GND	Rated current	Switch current
Condition		(+)	Wave form signal		Resistance	Resistance		12V	12V
Symbol									

GAUGES AND SETTING

Tachometer	RPM	1000	1500	2000	3000	3-WAY Hall type sensor
	Hz	236.5	354.75	473	709.5	

Speedometer	Km/h	30	60	2-WAY Electronic sensor
	Hz	128.6	257.2	

Hourmeter	After starting the engine, timer operates when receiving the 12V input of the instrument panel to integrate mileage					
-----------	---	--	--	--	--	--

Fuel level parameter	Stages	6	5	4	3	2	1st
	Stages value ± 1	$\leq 5\Omega$	$\leq 20\Omega$	$\leq 42\Omega$	$\leq 77\Omega$	$\leq 107\Omega$	$> 107\Omega$

Coolant parameter	Stages	6 (125°C)	5	4	3	2	1 (55°C)
	Stages value ± 1	$< 29\Omega$	≥ 30	≥ 33	≥ 39	≥ 88	$\geq 181\Omega$

MODE BUTTON / SET BUTTON

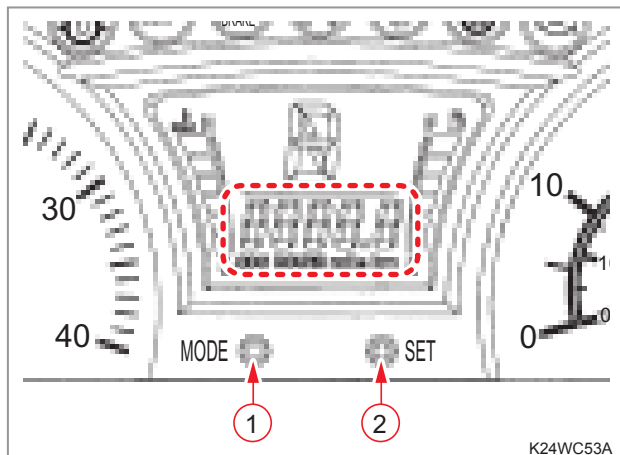

(1) Mode selection button (2) Set button

MODE SELECTION BUTTON	DISPLAY	NOTE
Push once	Odometer	Total mileage
Push twice	Hourmeter	Total time used
Push three times	Clock	Current Time

※ Press the Set button to switch the speed unit to Km or Mile.

- SAFETY FIRST
- GENERAL
- ENGINE
- CVT
- TRANSMISSION
- CHASSIS
- REAR AXLE
- BRAKE
- FRONT AXLE
- STEERING
- HYDRAULIC
- ELECTRIC**
- INDEX

SAFETY FIRST

GENERAL

ENGINE

CVT

TRANSMISSION

CHASSIS

REAR AXLE

BRAKE

FRONT AXLE

STEERING

HYDRAULIC

ELECTRIC

INDEX

5.19 POWER OUTLET



The power outlet (12 V) is installed to the lower side on the center of the main instrument panel.

SPECIFICATIONS

Rated voltage	DC 12V
Max. operating current (at rated voltage)	10A

5.20 FUSE & RELAY BOX

5.20.1 FUSE BOX



The fuse & relay box is attached to the left-front side in the hood.

- Function: It protects devices from excessive electric load.
- Operating principle: If the current through the fuse is over the specified capacity, the conductor of the fuse is blown to protect controller and circuit.

Conditions	Results
110% of rated current is applied	The fuse is not blown.
130% of rated current is applied	The fuse is blown within 60 seconds.
150% of rated current is applied	The regular fuse is blown within 15 seconds and the fuse for over 30 A is blown within 30 seconds.

K9 2400 SW(GW)

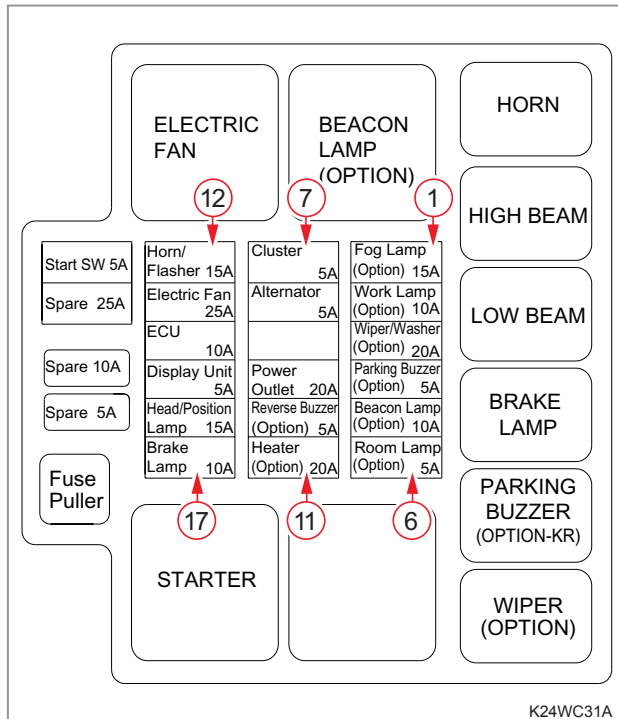

- Fuse 1 (15 A): Fog lamp (Option)
- Fuse 2 (10 A): Work lamp (Option)
- Fuse 3 (20 A): Wiper / Washer (Option)
- Fuse 4 (5 A): Parking buzzer (Option)
- Fuse 5 (10 A): Beacon lamp (Option)
- Fuse 6 (5 A): Room lamp (Option)
- Fuse 7 (5 A): Cluster
- Fuse 8 (5 A): Alternator
- Fuse 9 (20 A): Power outlet
- Fuse 10 (5 A): Reverse buzzer (Option)
- Fuse 11 (20 A): Heater (Option)
- Fuse 12 (15 A): Horn / Flasher
- Fuse 13 (25 A): Electric fan
- Fuse 14 (10 A): ECU
- Fuse 15 (5 A): Display unit
- Fuse 16 (15 A): Head lamp / Position lamp
- Fuse 17 (10 A): Brake lamp
- Spare fuse: 5 A, 10 A, 25 A

K9 2400D - AU, K9 2400 -EU

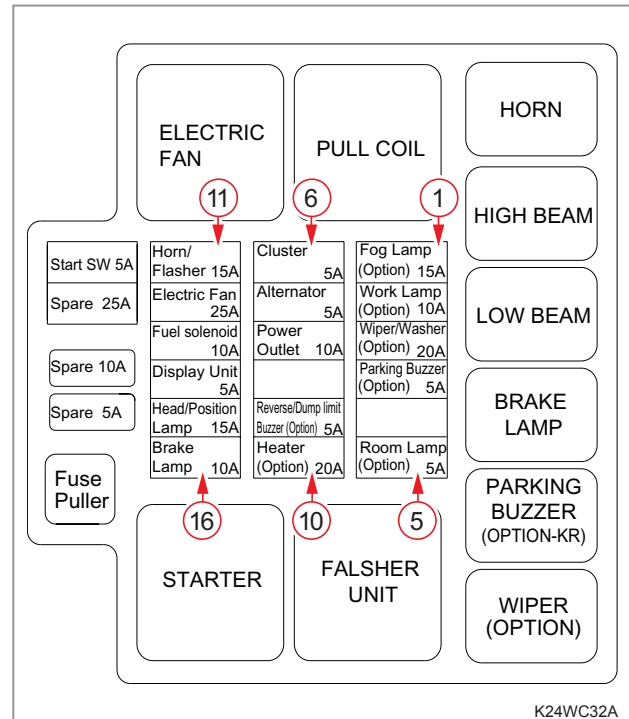

- Fuse 1 (15 A): Fog lamp (Option)
- Fuse 2 (10 A): Work lamp (Option)
- Fuse 3 (20 A): Wiper / Washer motor (Option)
- Fuse 4 (5 A): Parking buzzer (Option)
- Fuse 5 (5 A): Room lamp (Option)
- Fuse 6 (5 A): Cluster
- Fuse 7 (5 A): Alternator
- Fuse 8 (10 A): Power outlet
- Fuse 9 (5 A): Reverse / Dump limit buzzer (Option)
- Fuse 10 (20 A): Heater (Option)
- Fuse 11 (15 A): Horn / Flasher
- Fuse 12 (25 A): Electric fan
- Fuse 13 (25 A): Fuel solenoid
- Fuse 14 (5 A): Display unit
- Fuse 15 (15 A): Head lamp / Position lamp
- Fuse 16 (10 A): Brake lamp
- Spare fuse: 5 A, 10 A, 25 A

SAFETY FIRST
GENERAL
ENGINE
CVT
TRANSMISSION
CHASSIS
REAR AXLE
BRAKE
FRONT AXLE
STEERING
HYDRAULIC
ELECTRIC
INDEX

SAFETY FIRST

GENERAL

ENGINE

CVT

TRANSMISSION

CHASSIS

REAR AXLE

BRAKE

FRONT AXLE

STEERING

HYDRAULIC

ELECTRIC

INDEX

5.20.2 RELAY BOX

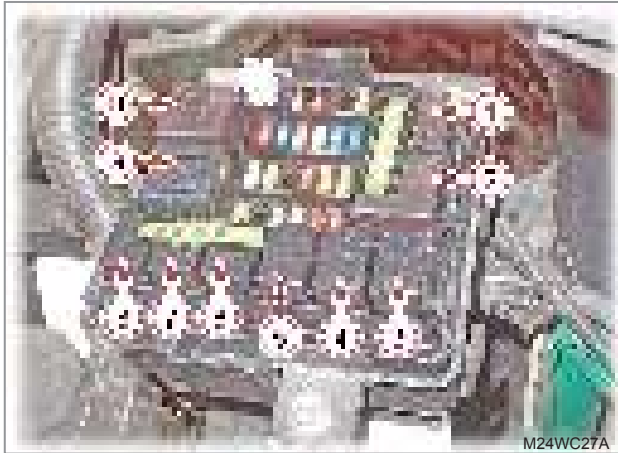

- (1) Electric fan relay
- (2) Beacon lamp relay (Option) : K9 2400 SW(GW)
Pull coil relay : K9 2400D - AU, K9 2400 -EU
- (3) Horn relay
- (4) High beam relay
- (5) Low beam relay
- (6) Brake lamp relay
- (7) Parking buzzer relay (Option-KR)
- (8) Wiper relay (Option)
- (9) Flasher unit : K9 2400D - AU, K9 2400 -EU
- (10) Starter relay

The type of relays are 4P or 5P, it supply power to the each components.

5P RELAY (1, 2, 9, 10)

- (1) Fan motor relay (5P)

The electric fan relay supply power to the electric fan motor.

- (2) Engine stop (pull coil) relay (5P)

This relay supply power to the pull coil of the engine stop solenoid.

- (9) Flasher unit

The flasher unit flashes the turn signal lamp or emergency lamp when lamp is operated.

- (10) Ignition relay (5P)

This relay supply power to the magnet coil of the starter motor, when the ignition switch is turned to the "ST" position.

► CONNECTOR AND TERMINAL DIAGRAM

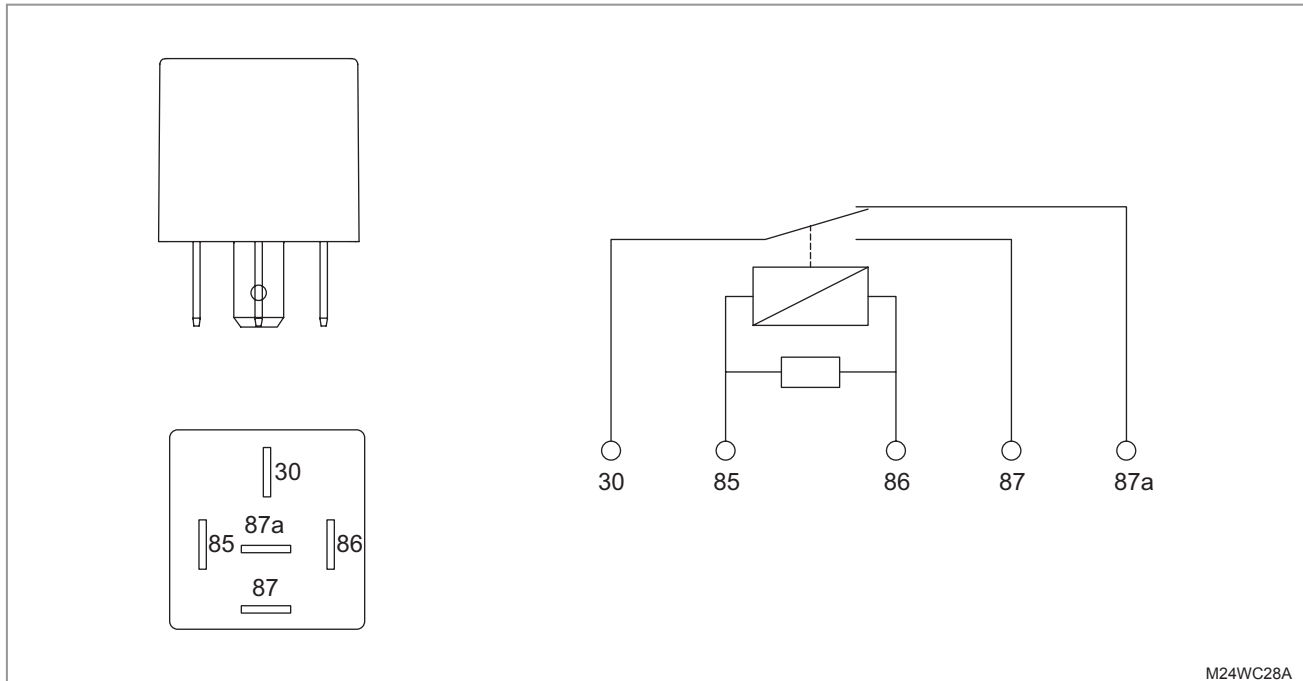

► RELAY TEST

Terminal diagram

T85WB36A

UUVWAB4A

To perform the relay test, remove the relay from the connector.

Check the resistance and continuity within the resistance range (Ω) of a tester.

Numbers on the auxiliary relay terminals indicate corresponding coil and contact.

- Capacity: 40A

Tester selector	Tester's measuring point		Result
	Red lead	Black lead	
Resistance	Relay No. 85	Relay No. 86	Approx. 86.5 ~ 87.0 Ω (15°C) Approx. 105 Ω
	Relay No. 30	Relay No. 87a	Continuity
	Relay No. 30	Relay No. 87	No continuity

※ When measuring the resistance with a tester, it is OK to switch the leads (red and black).

SAFETY FIRST

GENERAL

ENGINE

CVT

TRANSMISSION

CHASSIS

REAR AXLE

BRAKE

FRONT AXLE

STEERING

HYDRAULIC

ELECTRIC

INDEX

SAFETY FIRST

GENERAL

ENGINE

CVT

TRANSMISSION

CHASSIS

REAR AXLE

BRAKE

FRONT AXLE

STEERING

HYDRAULIC

ELECTRIC

INDEX

MICRO 4P RELAY (3, 4, 5, 6)

▶ CONNECTOR AND TERMINAL DIAGRAM

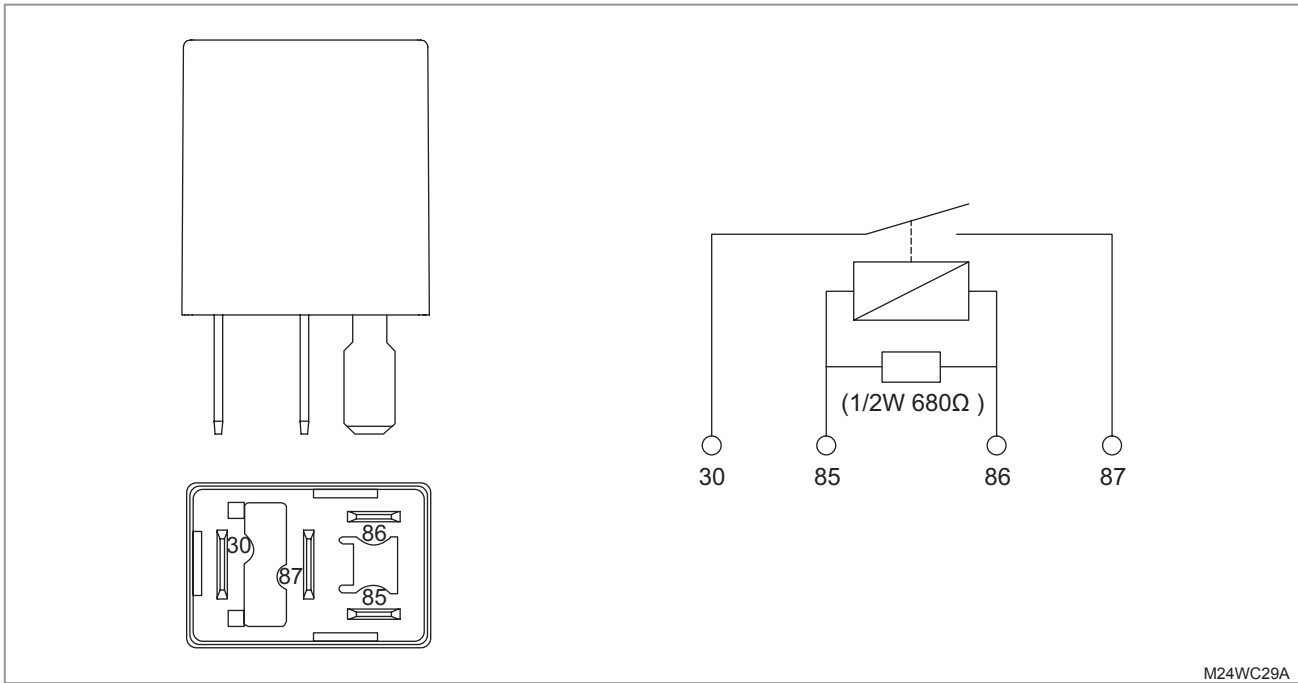

MICRO 5P RELAY (7, 8)

▶ CONNECTOR AND TERMINAL DIAGRAM

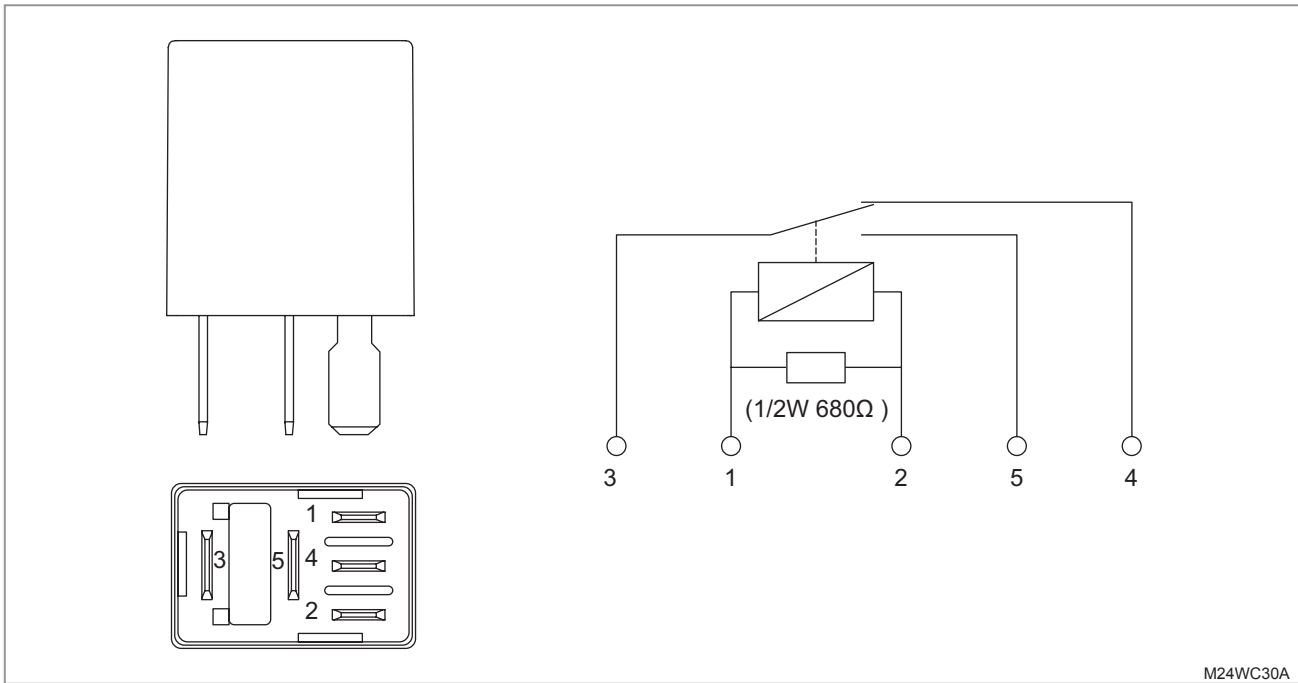

5.21 BRAKE LAMP SWITCH



The brake lamp switch is attached on the brake pedal.

The brake switch turns on the brake lamps of the tail lamps on the rear cargo bed when the brake pedal is depressed.

- N.C (Normally Closed) type:
It is normally closed (ON) but it is open (OFF) when contact point is pressed.

The brake pedal presses the switch when the brake is not applied.

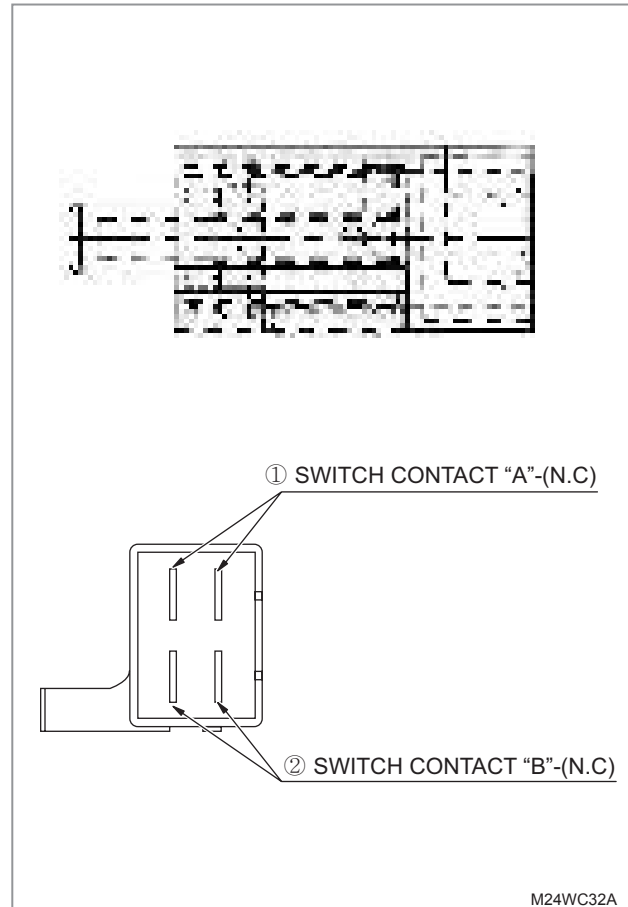

Tester selector	Tester's measuring point		Result	Remarks
	Red lead	Black lead		
Resistance	Connector ①	Connector ②	No operation (ON)	Continuity
	Connector ①	Connector ②	In operation (OFF)	No continuity

※ When measuring the resistance with a tester, it is OK to switch the leads (red and black).

SAFETY FIRST
GENERAL
ENGINE
CVT
TRANSMISSION
CHASSIS
REAR AXLE
BRAKE
FRONT AXLE
STEERING
HYDRAULIC
ELECTRIC
INDEX

SAFETY FIRST

GENERAL

ENGINE

CVT

TRANSMISSION

CHASSIS

REAR AXLE

BRAKE

FRONT AXLE

STEERING

HYDRAULIC

ELECTRIC

INDEX

5.22 ECU [K9 2400 SW(GW)]

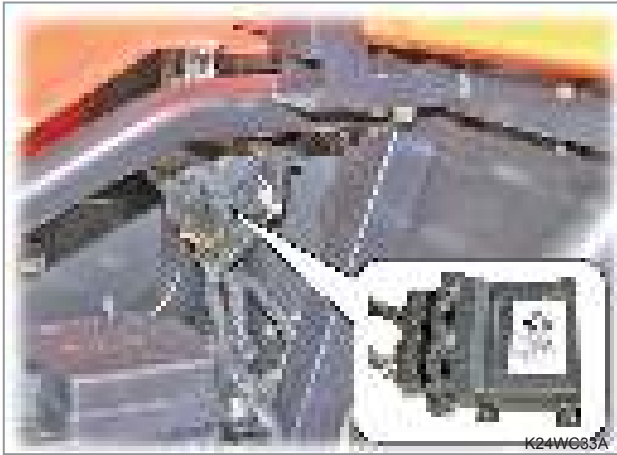

The ECU is installed in the hood. The ECU (Engine Control Unit) receives signals from various engine sensors, analyzes them and operates actuators accordingly to control the engine in the optimal condition.

- Operating temp : -40°C ~ +85°C (-40°F ~ +185°F)
- Nominal operating voltage : 14.5 VDC / 28.5 VDC

* For diagnosis, refer to the page of "3-44".

CONNECTOR

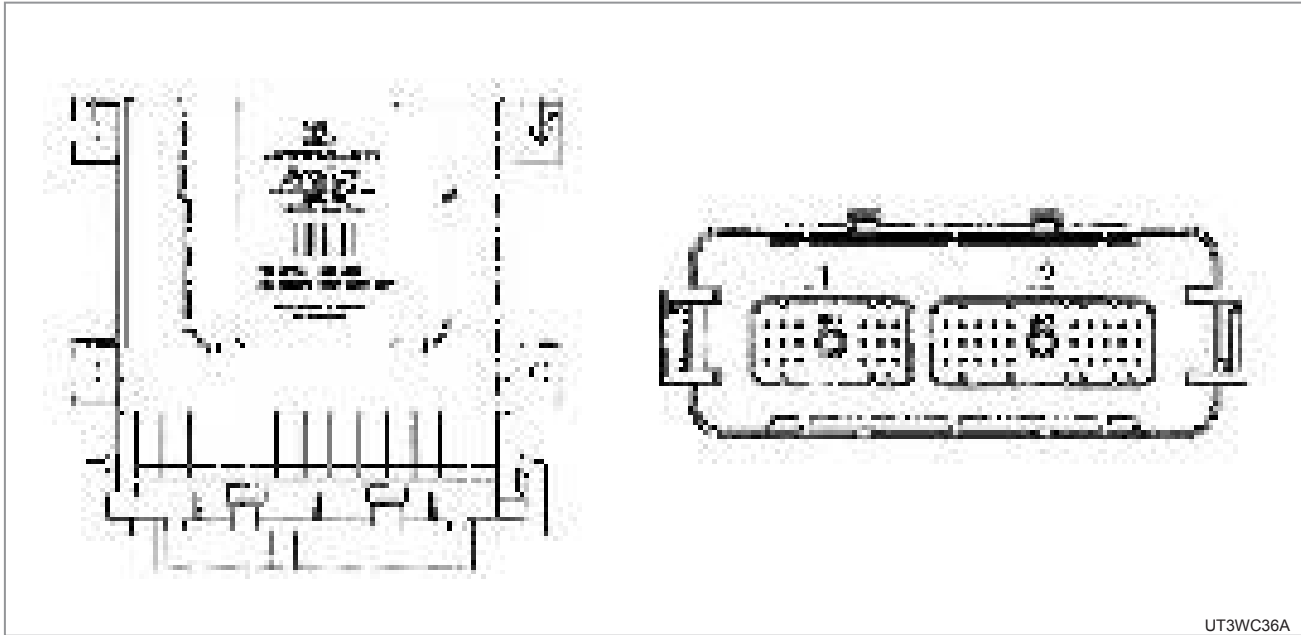

UT3WC36A

J1

	A	B	C	D	E	F
1	BAT +	BAT +	BAT -	D0_2	D0_2	D0_9
2	ACT +	BAT -	D0_7	D0_8	D0_6	CAN H1
3	ACT -	BAT -	D0_4	D0_1	D0_3	CAN H0

J2

	A	B	C	D	E	F	G	H	J	K
1	MPU +	APS +	SERIAL TXD	D1_2	D1_7	RSP +	DSP +	AirPS +	UNUSED	ECT +
2	MPU -	APS IN	SERIAL RXD	D1_3	D1_6	RSP IN	DSP IN	AirPS IN	UNUSED	ECT -
3	MPU SHIELD	APS -	SERIAL COM	D1_4	D1_5	RSP -	DSP -	AirPS -	RSP SHIELD	D1_1

5.22.1 ECU DIAGNOSTIC CONNECTOR

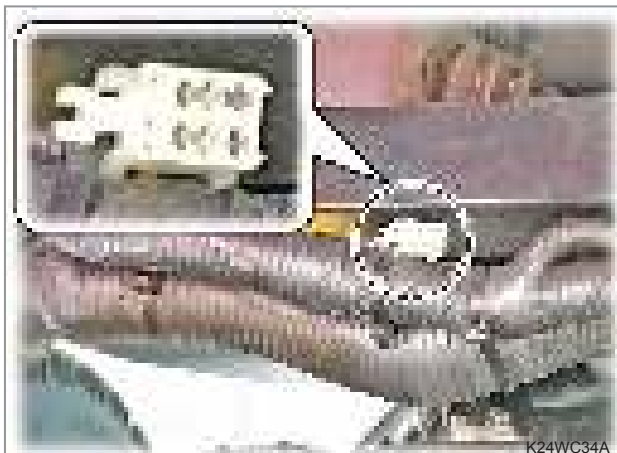

K24WC34A

The ECU diagnostic connector (1) is installed beside the ECU in the hood. It is connected to the ECU diagnostic device to check for any malfunction in the engine and correct any fault.

SAFETY FIRST

GENERAL

ENGINE

CVT

TRANSMISSION

CHASSIS

REAR AXLE

BRAKE

FRONT AXLE

STEERING

HYDRAULIC

ELECTRIC

INDEX

- SAFETY FIRST
- GENERAL
- ENGINE
- CVT
- TRANSMISSION
- CONNECTOR
- CHASSIS
- REAR AXLE
- BRAKE
- FRONT AXLE
- STEERING
- HYDRAULIC
- ELECTRIC**
- INDEX

5.23 ACTUATOR [K9 2400 SW(GW)]

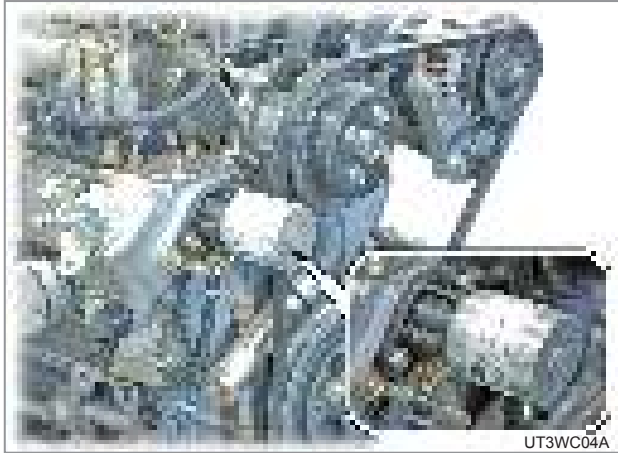

The actuator (position sensor) is installed to the engine gear case (where the engine stop solenoid is also installed) and it is controlled by the ECU to control the fuel feed amount of the engine.

- Rated voltage: 9 ~ 16 VDC
- Rated current: 4.3 A
- Temperature range: -30°C ~ 105°C (-22°F ~ 221°F)
- Pin stroke: 16 ± 0.81 mm (0.63 ± 0.032 in.)
- Sensor supply voltage: 5 VDC ± 10 %
- Sensor output voltage: 0.25 ~ 4.75 VDC

CONNECTOR

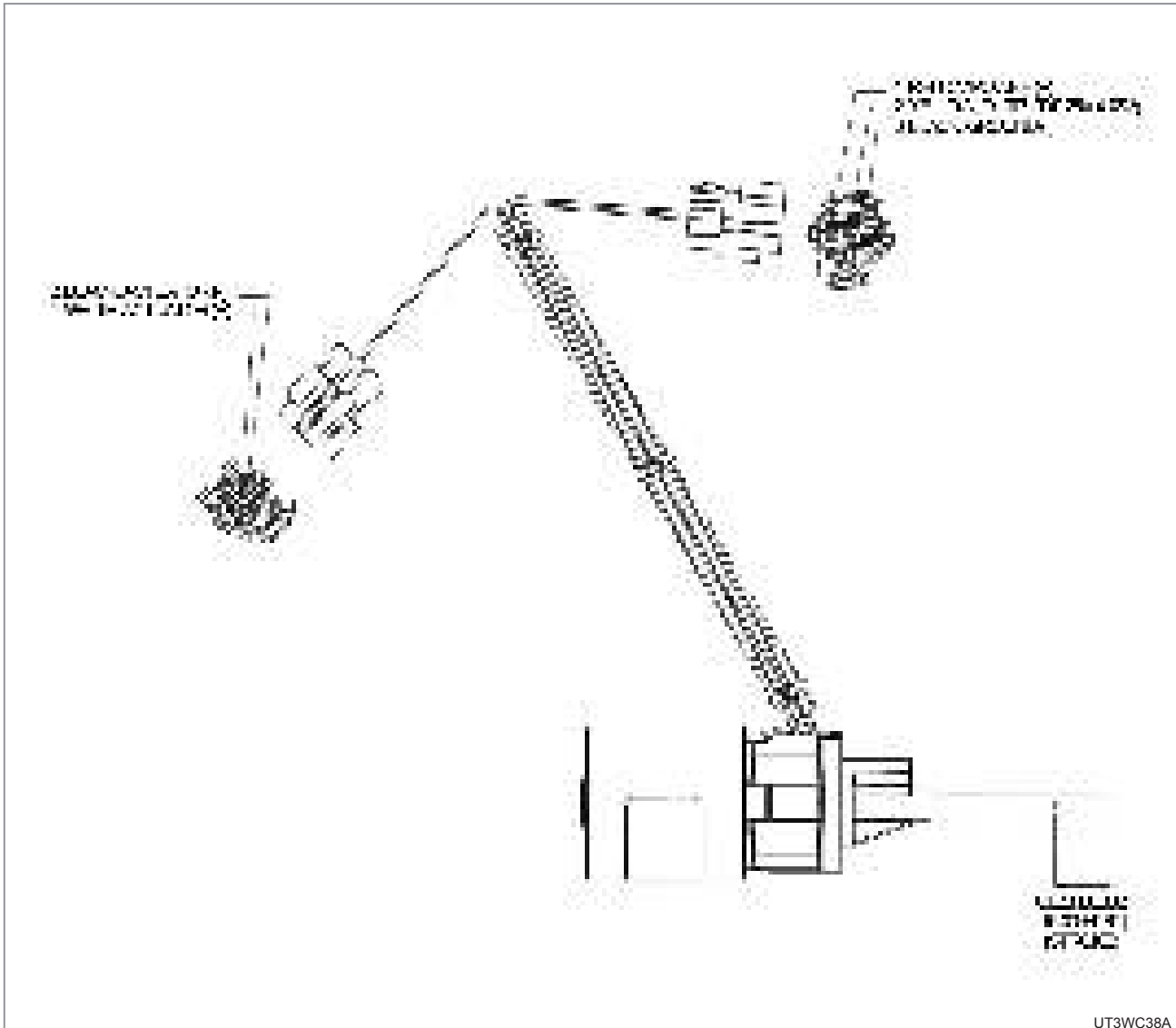

5.24 MPU(MAGNETIC PICK UP) SENSOR
[K9 2400 SW(GW)]



The MPU sensor is installed on the engine gear case. The pickup sensor detects the engine rpm signal. A signal from the pickup sensor is firstly supplied to the ECU and then determines ON/OFF operation of the hourmeter according to this signal.

5.25 ATMOSPHERIC PRESSURE SENSOR
[K9 2400 SW(GW)]



The atmospheric pressure sensor is installed. The atmospheric pressure sensor detects atmospheric pressure at the current location and sends this information to the ECU which then controls the fuel amount for proper fuel combustion.

- Sensor input voltage : 5 V
- Sensor output voltage : 0.25 ~ 4.7 V

CONNECTOR

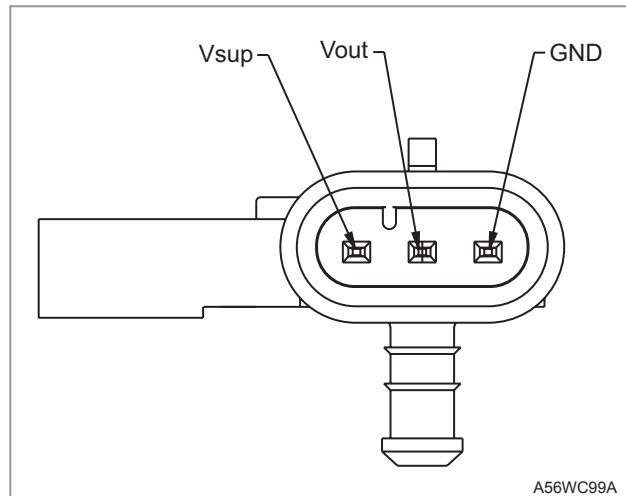

SAFETY FIRST
GENERAL
ENGINE
CVT
TRANSMISSION
CHASSIS
REAR AXLE
BRAKE
FRONT AXLE
STEERING
HYDRAULIC
ELECTRIC
INDEX



6. WIRING
6.1 MAIN HARNESS

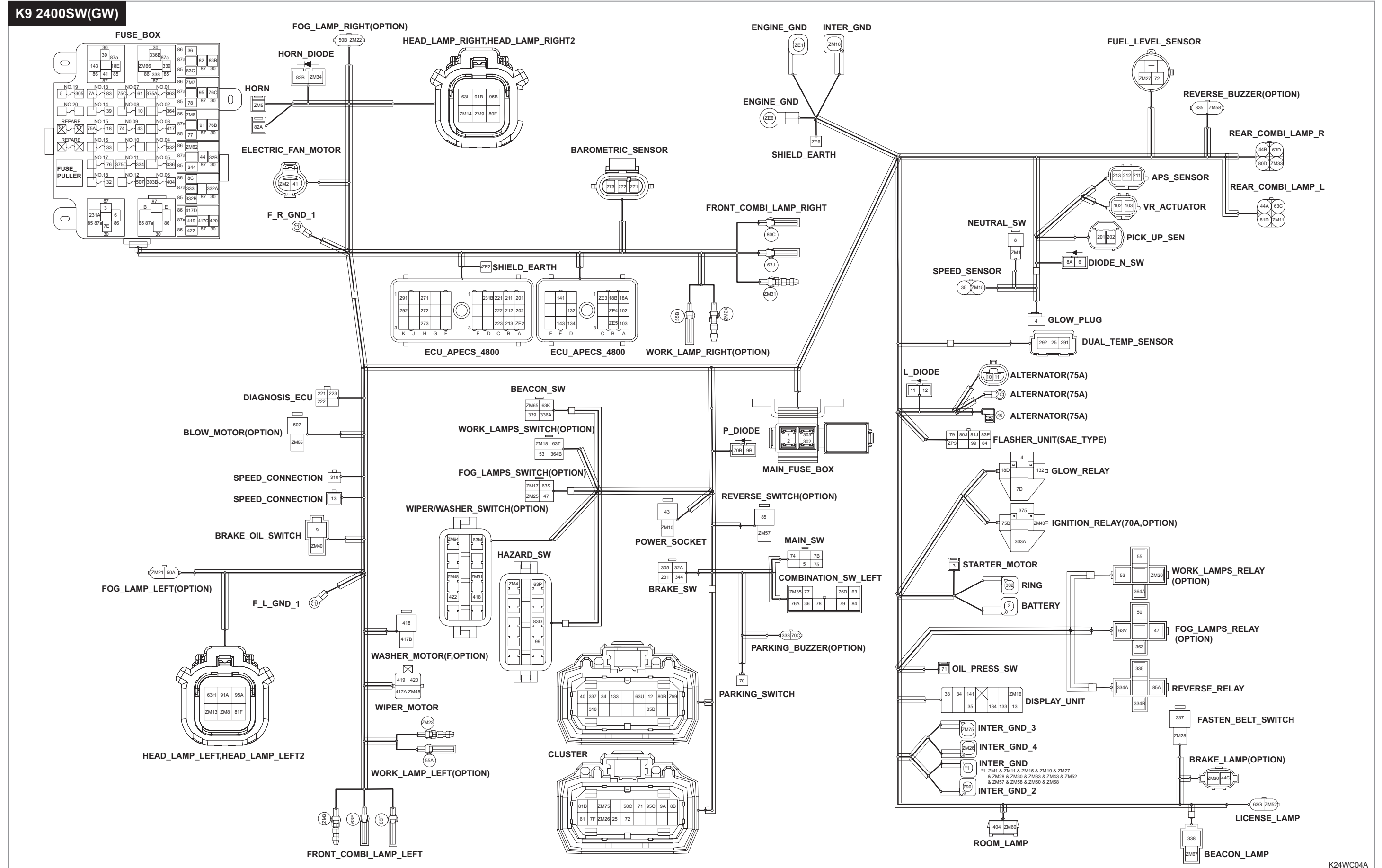

SAFETY FIRST
GENERAL
ENGINE
CVT
TRANSMISSION
CHASSIS
REAR AXLE
BRAKE
FRONT AXLE
STEERING
HYDRAULIC
ELECTRIC
INDEX

K9 2400SW(GW)

Wire Label	Size mm ²	Color	Wire Kind	Signal Name	Wire Label	Size mm ²	Color	Wire Kind	Signal Name	Wire Label	Size mm ²	Color	Wire Kind	Signal Name	Wire Label	Size mm ²	Color	Wire Kind	Signal Name
2	8	R	AEXF	B+12V	63J	0.5	Br	AVSS	POSITION_RH_OPTION	134	0.5	P	AVSS	DISPLAY_UNIT_CE_INPUT	ZE1	2	B	AVSS	ECU GND
3	3	R	AEXF	Start_M/S Signal	63K	0.85	Br	AVSS	BEACON_SW	141	0.5	B/R	AVSS	DISPLAY_UNIT_GLOW_INPUT	ZE2	0.5	B/Y	AVSS	PICK_UP(SHIELD_GND)(201,202,ZE2SHIELD)
4	5	B/R	AVS	Glow Plug	63L	0.5	Br	AVSS	POSITION_LAMPS	143	0.5	Y/B	AVSS	ELECTRIC_FAN_MOTOR_RELAY(-)OUTPUT	ZE3	0.85	B	AVSS	ECU GND
5	0.5	L/Y	AVSS	START_SWITCH	63M	0.85	Br	AVSS	WIPER_WASHER_SW	201	0.5	Y	AVSS	PICK_UP(+)(201,202,203SHIELD)	ZE4	0.85	B	AVSS	ECU GND
6	0.5	B/Y	AVSS	START_RELAY_COIL(-)	63P	0.85	Br	AVSS	HAZARD_SW_LAMP	202	0.5	Y/B	AVSS	PICK_UP(-)(201,202,203SHIELD)	ZE5	0.85	B	AVSS	ECU GND
7	8	R	AEXF	B+12V	63S	0.85	Br	AVSS	FOG_LAMP_SW	211	0.5	R/W	AVSS	APS_SENSOR(5V)(211,212,213TWIST)	ZE6	0.5	B	AVSS	RS232_SHIELD_GND(221,222,223SHIELD)
7A	8	R	AEXF	B+12V	63T	0.85	Br	AVSS	WORK_LAMP_SW	212	0.5	Y/W	AVSS	APS_SENSOR(SIGNAL)(211,212,213TWIST)	ZM1	0.5	B	AVSS	Start Signal +12V
7B	3	R	AEXF	B+12V	63U	0.85	Br	AVSS	TAIL_LAMP	213	0.5	B/W	AVSS	APS_SENSOR(GND)(211,212,213TWIST)	ZM2	3	B	AEXF	GND
7C	8	R	AEXF	B+12V	63V	0.5	Br	AVSS		221	0.5	L/Y	AVSS	RS232_TXD(221,222,223SHIELD)	ZM3	0.5	B	AVSS	GND
7D	5	R	AEXF	B+12V	70	0.5	W	AVSS	PARKING_SWITCH	222	0.5	L/G	AVSS	RS232_RXD(221,222,223SHIELD)	ZM4	0.85	B	AVSS	GND
7E	3	R	AEXF	Power_Start +12V	70B	0.5	W	AVSS	PARKING_SWITCH	223	0.5	B/L	AVSS	RS232_GND(221,222,223SHIELD)	ZM5	0.85	B	AVSS	GND
7F	0.85	R	AVSS	B+12V	70C	0.5	W	AVSS	PARKING_SWITCH	231	0.5	R/Y	AVSS	START_RELAY_COIL(+)	ZM6	0.85	B	AVSS	GND
8	0.5	B/L	AVSS	NEUTRAL SIG	71	0.5	Gr	AVSS	Oil Pressure Signal	231A	0.5	R/Y	AVSS	START_RELAY_COIL(+)	ZM7	0.85	B	AVSS	GND
8A	0.5	B/L	AVSS	NEUTRAL SIG	72	0.5	Y/B	AVSS	FUEL GAUGE SENSOR	231B	0.5	R/Y	AVSS	Start Relay (+) coil	ZM8	0.85	B	AVSS	GND
8B	0.5	B/L	AVSS	NEUTRAL LAMP SIG	74	2	R/B	AVSS	ACC power	271	0.5	R/B	AVSS	BAROMETRIC_SENSOR_5V(271,272,273TWIST)	ZM9	0.85	B	AVSS	GND
8C	0.5	B/L	AVSS	NEUTRAL_SWITCH	75	3	R/W	AEXF	KEY-ON	272	0.5	Y/B	AVSS	BAROMETRIC_SENSOR_SIGNAL(271,272,273TWIST)	ZM10	2	B	AVSS	GND
9	0.5	G/B	AVSS	BRAKE_OIL_SWITCH	75A	3	R/W	AEXF	KEY-ON	273	0.5	B/R	AVSS	BAROMETRIC_SENSOR_GND(271,272,273TWIST)	ZM11	0.85	B	AVSS	GND
9A	0.5	G/B	AVSS	BRAKE_OIL_SWITCH	75B	0.85	R/W	AVSS	KEY-ON	291	0.5	W/R	AVSS	TEMP_SENSOR(GLOW)	ZM12	0.85	B	AVSS	GND
9B	0.5	G/B	AVSS	BRAKE_OIL_SWITCH	75C	1.25	R/W	AVSS	KEY-ON	292	0.5	B/R	AVSS	TEMP_SENSOR(GLOW)GND	ZM13	0.5	B	AVSS	GND
10	0.85	R/L	AVSS	ALTERNATOR_R	76	1.25	R/Y	AVSS	HEAD_LAMPS_POWER	302	8	R	AEXF	IGN_B+	ZM14	0.5	B	AVSS	GND
11	0.5	P	AVSS	ALTERNATOR_L	76A	0.85	R/Y	AVSS	POSITION_LAMPS_POWER	303	8	R	AEXF	F_IGN_B+	ZM15	0.5	B	AVSS	GND
12	0.5	P/B	AVSS	Charge signal	76B	0.85	R/Y	AVSS	LOW_BEAM_RELAY_POWER	303A	8	R	AEXF	F_IGN_B+	ZM16	0.85	B	AVSS	GND
13	0.5	W/Y	AVSS	SPEEDMETER SIG	76C	0.85	R/Y	AVSS	HIGH_BEAM_RELAY_POWER	303B	0.85	R	AVSS	F_IGN_B+	ZM17	0.5	B	AVSS	GND
18	1.25	R/W	AVSS	ECU_Power(KEY ON)	76D	0.85	R/Y	AVSS	COMBI_SW_B2	305	0.5	R/Y	AVSS	F_START_SWITCH	ZM18	0.5	B	AVSS	GND
18A	0.85	R/W	AVSS	ECU_POWER(KEY_ON)(18A,18B_TWIST)	77	0.5	W/R	AVSS	LOW_BEAM_SWITCH	310	0.5	Y/L	AVSS	SPEEDMETER SIG	ZM19	0.85	B	AVSS	GND
18B	0.85	R/W	AVSS	ECU_POWER(KEY_ON)(18A,18B_TWIST)	78	0.5	Br/R	AVSS	HIGH_BEAM_SWITCH	332	0.5	R/G	AVSS	PARKING_BUZZER(OPTION)POWER	ZM20	0.5	B	AVSS	GND
18D	0.5	R/W	AVSS	GLOW_RELAY_COIL(+)	79	0.85	Br	AVSS	Turn Signal RH	332A	0.5	R/G	AVSS	PARKING_BUZZER(OPTION)POWER	ZM21	0.5	B	AVSS	GND
18E	0.5	R/W	AVSS	ELECTRIC_FAN_MOTOR_RELAY_POWER	80B	0.5	G/W	AVSS	Turn Signal RH	332B	0.5	R/G	AVSS	PARKING_BUZZER(OPTION)POWER	ZM22	0.5	B	AVSS	GND
25	0.5	W/B	AVSS	Temp. Gauge Signal	80C	0.5	G/W	AVSS	TURN_SIGNAL_RH_OPTION	333	0.5	R/L	AVSS	PARKING_BUZZER(OPTION)	ZM23	0.5	B	AVSS	GND
32	0.85	Y/G	AVSS	BRAKE_LAMPS_POWER	80D	0.5	G/W	AVSS	Turn Signal RH	334	0.5	R/G	AVSS	REVERSE_LAMP/BUZZER/DUMP_LIMIT_BUZZER(OPTION)POWER	ZM24	0.5	B	AVSS	GND
32A	0.85	Y/G	AVSS	BRAKE_LAMPS_POWER	80F	0.5	G/W	AVSS	Turn Signal RH	334A	0.5	R/G	AVSS	REVERSE_LAMP/BUZZER/DUMP_LIMIT_BUZZER(OPTION)POWER	ZM25	0.5	B	AVSS	GND
32B	0.85	Y/G	AVSS	BRAKE_LAMPS_POWER	80J	0.85	G/W	AVSS	FLASHER_TURN_RH	334B	0.5	R/G	AVSS	REVERSE_LAMP/BUZZER/DUMP_LIMIT_BUZZER(OPTION)	ZM26	0.5	B	AVSS	GND
33	0.85	R/B	AVSS	DISPLAY_UNIT_POWER	81B	0.5	W/R	AVSS	Turn Signal LH	335	0.5	G/Y	AVSS	REVERSE_BUZZER_POWER	ZM27	0.5	B	AVSS	GND
34	0.5	Gr	AVSS	GLOW LAMP(+)	81D	0.5	W/R	AVSS	Turn Signal LH	336	1.25	P	AVSS	BEACON_SIGNAL	ZM28	0.5	B	AVSS	FASTEN_BELT_SWITCH_GND
35	0.5	Y/W	AVSS	SPEED SENSOR SIGNAL	81F	0.5	W/R	AVSS	Turn Signal LH	336A	0.5	P	AVSS	BEACON_SW	ZM30	0.5	B	AVSS	GND
36	0.5	W/B	AVSS	HORN_SWITCH	81J	0.85	R/W	AVSS	FLASHER_TURN_L	336B	1.25	P	AVSS	BEACON_RELAY	ZM31	0.5	B	AVSS	GND
39	3	R	AEXF	ELECTRIC_FAN_MOTOR_POWER	82	0.85	L/B	AVSS	Horn signal	337	0.5	G	AVSS	FASTEN_BELT_SWITCH	ZM32	2	B	AVSS	GND
40	0.5	W	AVSS	ALTERNATOR_P_SIGNAL	82A	0.85	L/B	AVSS	Horn signal	338	1.25	L	AVSS	BEACON_LAMP	ZM33	0.85	B	AVSS	GND
41	3	L	AEXF	Start_M/S Signal	82B	0.5	L/B	AVSS	HORN_DIODE	339	0.5	Gr	AVSS	BEACON_SW-RELAY	ZM34	0.5	B	AVSS	HORN_DIODE_GND
43	2	R/B	AVSS	POWER_OUTLET_POWER	83	1.25	Lg	AVSS	HORN_FLASHER_POWER	344	0.5	R/W	AVSS	BRAKE_LAMP_SWITCH	ZM35	0.5	B	AVSS	HORN_SWITCH_GND
44	0.85	R/W	AVSS	Stop_lamp_Signal	83A	1.25	Lg	AVSS	Flasher power(B+ 15A)	363	1.25	R/B	AVSS	FOG_LAMPS(OPTION)POWER	ZM40	0.5	B	AVSS	BRAKE_OIL_SWITCH_GND
44A	0.5	R/W	AVSS	BRAKE_LAMP_L	83B	0.85	Lg	AVSS	HORN POWER	364	0.85	Gr	AVSS	WORK_LAMPS(OPTION)POWER	ZM43	0.85	B	AVSS	IGN_RELAY_COIL_GND
44B	0.5	R/W	AVSS	BRAKE_LAMP_R	83C	0.5	Lg	AVSS	HORN POWER	364A	0.85	Gr	AVSS	WORK_LAMPS(OPTION)POWER	ZM48	0.5	B	AVSS	WIPER_SWITCH(OPTION)GND
44C	0.5	R/W	AVSS	BRAKE_LAMP2_L(OPTION)	83D	0.85	Lg	AVSS	HAZARD_SW	364B	0.5	Gr	AVSS	WORK_LAMPS(OPTION)POWER	ZM49	1.25	B	AVSS	WIPER_MOTOR(OPTION)GND
47	0.5	W/L	AVSS		83E	1.25	Lg	AVSS	Flasher power(B+ 15A)	375	8	R	AEXF	IGN_OPTION_POWER	ZM50	2	B	AVSS	WIPER/WASHER_MOTOR(OPTION)GND
50	1.25	Y/L	AVSS	FOG_LAMPS(OPTION)	84	0.85	W/R	AVSS	Turn Signal LH	375A	5	R	AEXF	IGN_OPTION_POWER	ZM51	0.5	B	AVSS	WASHER_SWITCH(OPTION)GND
50A	1.25	Y/L	AVSS	FOG_LAMP_LEFT(OPTION)	85	0.5	B/G	AVSS	REVERSE_SWITCH(OPTION)	375C	1.25	R	AVSS	IGN_OPTION_POWER	ZM52	0.5	B	AVSS	LEICENSE_LAMP_RIGHT_GND
50B	0.85	Y/L	AVSS	FOG_LAMP_RIGHT(OPTION)	85A	0.5	B/G	AVSS	REVERSE_SWITCH(OPTION)	404	0.85	R/G	AVSS	ROOM LAMP POWER	ZM55	1.25	B	AVSS	HEATER(OPTION)GND
50C	0.5	Y/L	AVSS	FOG_LAMP	85B	0.5	B/G	AVSS	REVERSE_SWITCH(OPTION)	417	2	R/B	AVSS	WIPER/WASHER_MOTOR(OPTION)POWER	ZM57	0.5	B	AVSS	REVERSE_LAMP/BUZZER/DUMP_LIMIT_BUZZER(OPTION)GND
53	0.5	L	AVSS	WORK_LAMPS(OPTION)SWITCH	91	0.85	W	AVSS	HEADLAMP LOW	417A	1.25	R/B	AVSS	WIPER_MOTOR(OPTION)POWER	ZM58	0.5	B	AVSS	REVERSE_LAMP/BUZZER/DUMP_LIMIT_BUZZER(OPTION)GND
55	0.85	G/L	AVSS	WORK_LAMPS(OPTION)	91A	0.85	W	AVSS	LOW_BEAM_LEFT	417B	0.5	R/B	AVSS	WASHER_MOTOR(OPTION)POWER	ZM60	0.85	B	AVSS	ROOM_LAMP_GND
55A	0.5	G/L	AVSS	WORK_LAMP_LEFT(OPTION)	91B	0.85	W	AVSS	LOW_BEAM_RIGHT	417C	1.25	R/B	AVSS	WIPER_MOTOR(OPTION)POWER	ZM62	0.5	B	AVSS	BRAKE_LAMP_RELAY_GND
55B	0.5	G/L	AVSS	WORK_LAMP_RIGHT(OPTION)	95	0.85	Br	AVSS	HEADLAMP HIGH	417D	0.5	R/B	AVSS	WIPER_RELAY_COIL(OPTION)POWER	ZM64	0.85	B	AVSS	WIPER_GND
61	0.5	R/Y	AVSS	CLUSTER_POWER	95A	0.85	Br	AVSS	HEADLAMP HIGH	418	0.5	Br	AVSS	WASHER_SWITCH(OPTION)	ZM65	0.85	B	AVSS	BEACON_GND
63	0.85	Br	AVSS	POSITION_LAMP_SWITCH	95B	0.85	Br	AVSS	HEADLAMP HIGH	419	1.25	W	AVSS	WIPER_MOTOR(OPTION)PARK	ZM66	0.5	B	AVSS	BEACON_GND
63C	0.5	Br	AVSS	POSITION_LAMPS	95C	0.5	Br	AVSS	HEADLAMP HIGH	420	1.25	G	AVSS	WIPER_MOTOR(OPTION)COM	ZM67	1.25	B	AVSS	BEACON_LAMP_GND
63D	0.5	Br	AVSS	POSITION_LAMPS	99	0.85	G	AVSS	Flasher Signal	422	0.5	G/B	AVSS	WIPER_SWITCH(OPTION)	ZM68	0.85	B	AVSS	BEACON_GND
63E	0.5	Br	AVSS	TURN_SIGNAL_LH_OPTION	102	0.85	R	AVSS	VR_ACTUATOR_POWER(102,103TWIST)	507	1.25	R/L	AVSS	HEATER(OPTION)POWER	ZM75	0.5	B	AVSS	CLUSTER_GND_B_2
63F	0.5	Br	AVSS	POSITION_LH_OPTION	103	0.85	B/R	AVSS	VR_ACTUATOR_OUTPUT(102,103TWIST)	Z99	0.5	B	AVSS	TACHO GND	ZP3	1.25	B	AVSS	GND
63G	0.5	Br	AVSS	POSITION_LAMPS	132	0.5	B/R	AVSS	GLOW_SIGNAL										
63H	0.5	Br	AVSS	POSITION_LAMPS	133	0.5	P/B	AVSS	CEL_LAMP(-)										

K24WC05A

K9 2440SW(GW)

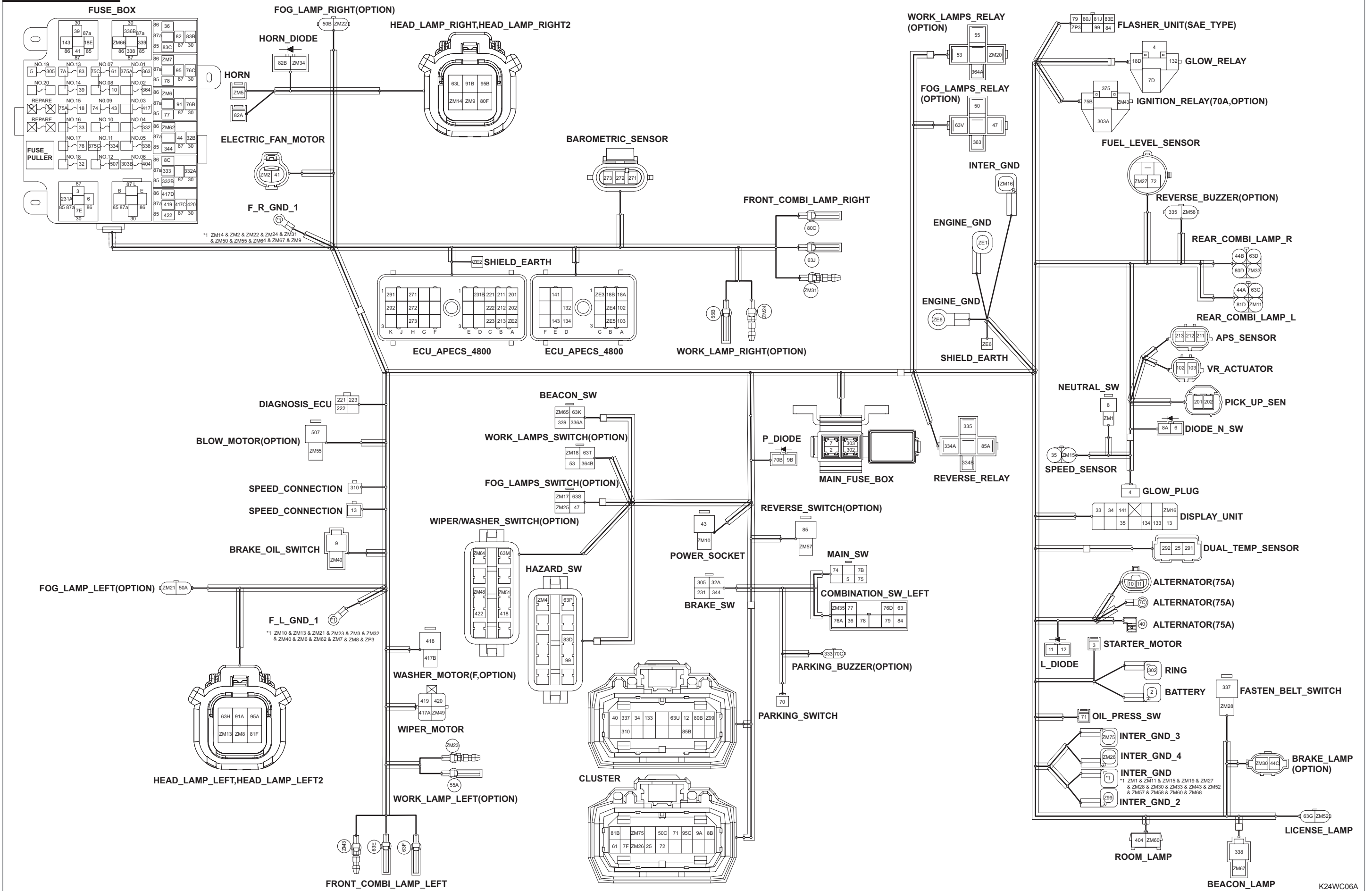

- SAFETY FIRST
- GENERAL
- ENGINE
- CVT
- TRANSMISSION
- CHASSIS
- REAR AXLE
- BRAKE
- FRONT AXLE
- STEERING
- HYDRAULIC
- ELECTRIC
- INDEX

K9 2440SW(GW)

Wire Label	Size mm ²	Color	Wire Kind	Signal Name	Wire Label	Size mm ²	Color	Wire Kind	Signal Name	Wire Label	Size mm ²	Color	Wire Kind	Signal Name	Wire Label	Size mm ²	Color	Wire Kind	Signal Name
2	8	R	AEXF	B+12V	63J	0.5	Br	AVSS	POSITION_RH_OPTION	134	0.5	P	AVSS	DISPLAY_UNIT_CE_INPUT	ZE1	2	B	AVSS	ECU GND
3	3	R	AEXF	Start_M/S Signal	63K	0.85	Br	AVSS	BEACON_SW	141	0.5	B/R	AVSS	DISPLAY_UNIT_GLOW_INPUT	ZE2	0.5	B/Y	AVSS	PICK_UP(SHIELD_GND)(201,202,ZE2SHIELD)
4	5	B/R	AVS	Glow Plug	63L	0.5	Br	AVSS	POSITION_LAMPS	143	0.5	Y/B	AVSS	ELECTRIC_FAN_MOTOR_RELAY(-)OUTPUT	ZE3	0.85	B	AVSS	ECU GND
5	0.5	L/Y	AVSS	START_SWITCH	63M	0.85	Br	AVSS	WIPER_WASHER_SW	201	0.5	Y	AVSS	PICK_UP(+)(201,202,203SHIELD)	ZE4	0.85	B	AVSS	ECU GND
6	0.5	B/Y	AVSS	START_RELAY_COIL(-)	63P	0.85	Br	AVSS	HAZARD_SW_LAMP	202	0.5	Y/B	AVSS	PICK_UP(-)(201,202,203SHIELD)	ZE5	0.85	B	AVSS	ECU GND
7	8	R	AEXF	B+12V	63S	0.85	Br	AVSS	FOG_LAMP_SW	211	0.5	R/W	AVSS	APS_SENSOR(5V)(211,212,213TWIST)	ZE6	0.5	B	AVSS	RS232_SHIELD_GND(221,222,223SHIELD)
7A	8	R	AEXF	B+12V	63T	0.85	Br	AVSS	WORK_LAMP_SW	212	0.5	Y/W	AVSS	APS_SENSOR(SIGNAL)(211,212,213TWIST)	ZM1	0.5	B	AVSS	Start Signal +12V
7B	3	R	AEXF	B+12V	63U	0.85	Br	AVSS	TAIL_LAMP	213	0.5	B/W	AVSS	APS_SENSOR(GND)(211,212,213TWIST)	ZM2	3	B	AEXF	GND
7C	8	R	AEXF	B+12V	63V	0.5	Br	AVSS		221	0.5	L/Y	AVSS	RS232_TXD(221,222,223SHIELD)	ZM3	0.5	B	AVSS	GND
7D	5	R	AEXF	B+12V	70	0.5	W	AVSS	PARKING_SWITCH	222	0.5	L/G	AVSS	RS232_RXD(221,222,223SHIELD)	ZM4	0.85	B	AVSS	GND
7E	3	R	AEXF	Power_Start +12V	70B	0.5	W	AVSS	PARKING_SWITCH	223	0.5	B/L	AVSS	RS232_GND(221,222,223SHIELD)	ZM5	0.85	B	AVSS	GND
7F	0.85	R	AVSS	B+12V	70C	0.5	W	AVSS	PARKING_SWITCH	231	0.5	R/Y	AVSS	START_RELAY_COIL(+)	ZM6	0.85	B	AVSS	GND
8	0.5	B/L	AVSS	NEUTRAL SIG	71	0.5	Gr	AVSS	Oil Pressure Signal	231A	0.5	R/Y	AVSS	START_RELAY_COIL(+)	ZM7	0.85	B	AVSS	GND
8A	0.5	B/L	AVSS	NEUTRAL SIG	72	0.5	Y/B	AVSS	FUEL GAUGE SENSOR	231B	0.5	R/Y	AVSS	Start_Relay (+) coil	ZM8	0.85	B	AVSS	GND
8B	0.5	B/L	AVSS	NEUTRAL LAMP SIG	74	2	R/B	AVSS	ACC power	271	0.5	R/B	AVSS	BAROMETRIC_SENSOR_5V(271,272,273TWIST)	ZM9	0.85	B	AVSS	GND
8C	0.5	B/L	AVSS	NEUTRAL_SWITCH	75	3	R/W	AEXF	KEY-ON	272	0.5	Y/B	AVSS	BAROMETRIC_SENSOR_SIGNAL(271,272,273TWIST)	ZM10	2	B	AVSS	GND
9	0.5	G/B	AVSS	BRAKE_OIL_SWITCH	75A	3	R/W	AEXF	KEY-ON	273	0.5	B/R	AVSS	BAROMETRIC_SENSOR_GND(271,272,273TWIST)	ZM11	0.85	B	AVSS	GND
9A	0.5	G/B	AVSS	BRAKE_OIL_SWITCH	75B	0.85	R/W	AVSS	KEY-ON	291	0.5	W/R	AVSS	TEMP_SENSOR(GLOW)	ZM12	0.85	B	AVSS	GND
9B	0.5	G/B	AVSS	BRAKE_OIL_SWITCH	75C	1.25	R/W	AVSS	KEY-ON	292	0.5	B/R	AVSS	TEMP_SENSOR(GLOW)GND	ZM13	0.5	B	AVSS	GND
10	0.85	R/L	AVSS	ALTERNATOR_R	76	1.25	R/Y	AVSS	HEAD_LAMPS_POWER	302	8	R	AEXF	IGN_B+	ZM14	0.5	B	AVSS	GND
11	0.5	P	AVSS	ALTERNATOR_L	76A	0.85	R/Y	AVSS	POSITION_LAMPS_POWER	303	8	R	AEXF	F_IGN_B+	ZM15	0.5	B	AVSS	GND
12	0.5	P/B	AVSS	Charge signal	76B	0.85	R/Y	AVSS	LOW_BEAM_RELAY_POWER	303A	8	R	AEXF	F_IGN_B+	ZM16	0.85	B	AVSS	GND
13	0.5	W/Y	AVSS	SPEEDMETER SIG	76C	0.85	R/Y	AVSS	HIGH_BEAM_RELAY_POWER	303B	0.85	R	AVSS	F_IGN_B+	ZM17	0.5	B	AVSS	GND
18	1.25	R/W	AVSS	ECU_Power(KEY ON)	76D	0.85	R/Y	AVSS	COMBI_SW_B2	305	0.5	R/Y	AVSS	F_START_SWITCH	ZM18	0.5	B	AVSS	GND
18A	0.85	R/W	AVSS	ECU_POWER(KEY_ON)(18A,18B_TWIST)	77	0.5	W/R	AVSS	LOW_BEAM_SWITCH	310	0.5	Y/L	AVSS	SPEEDMETER SIG	ZM19	0.85	B	AVSS	GND
18B	0.85	R/W	AVSS	ECU_POWER(KEY_ON)(18A,18B_TWIST)	78	0.5	Br/R	AVSS	HIGH_BEAM_SWITCH	332	0.5	R/G	AVSS	PARKING_BUZZER(OPTION)POWER	ZM20	0.5	B	AVSS	GND
18D	0.5	R/W	AVSS	GLOW_RELAY_COIL(+)	79	0.85	Br	AVSS	Turn Signal RH	332A	0.5	R/G	AVSS	PARKING_BUZZER(OPTION)POWER	ZM21	0.5	B	AVSS	GND
18E	0.5	R/W	AVSS	ELECTRIC_FAN_MOTOR_RELAY_POWER	80B	0.5	G/W	AVSS	Turn Signal RH	332B	0.5	R/G	AVSS	PARKING_BUZZER(OPTION)POWER	ZM22	0.5	B	AVSS	GND
25	0.5	W/B	AVSS	Temp. Gauge Signal	80C	0.5	G/W	AVSS	TURN_SIGNAL_RH_OPTION	333	0.5	R/L	AVSS	PARKING_BUZZER(OPTION)	ZM23	0.5	B	AVSS	GND
32	0.85	Y/G	AVSS	BRAKE_LAMPS_POWER	80D	0.5	G/W	AVSS	Turn Signal RH	334	0.5	R/G	AVSS	REVERSE_LAMP/BUZZER/DUMP_LIMIT_BUZZER(OPTION)POWER	ZM24	0.5	B	AVSS	GND
32A	0.85	Y/G	AVSS	BRAKE_LAMPS_POWER	80F	0.5	G/W	AVSS	Turn Signal RH	334A	0.5	R/G	AVSS	REVERSE_LAMP/BUZZER/DUMP_LIMIT_BUZZER(OPTION)POWER	ZM25	0.5	B	AVSS	GND
32B	0.85	Y/G	AVSS	BRAKE_LAMPS_POWER	80J	0.85	G/W	AVSS	FLASHER_TURN_RH	334B	0.5	R/G	AVSS	REVERSE_LAMP/BUZZER/DUMP_LIMIT_BUZZER(OPTION)	ZM26	0.5	B	AVSS	GND
33	0.85	R/B	AVSS	DISPLAY_UNIT_POWER	81B	0.5	W/R	AVSS	Turn Signal LH	335	0.5	G/Y	AVSS	REVERSE_BUZZER_POWER	ZM27	0.5	B	AVSS	GND
34	0.5	Gr	AVSS	GLOW LAMP(+)	81D	0.5	W/R	AVSS	Turn Signal LH	336	1.25	P	AVSS	BEACON_SIGNAL	ZM28	0.5	B	AVSS	FASTEN_BELT_SWITCH_GND
35	0.5	Y/W	AVSS	SPEED SENSOR SIGNAL	81F	0.5	W/R	AVSS	Turn Signal LH	336A	0.5	P	AVSS	BEACON_SW	ZM30	0.5	B	AVSS	GND
36	0.5	W/B	AVSS	HORN_SWITCH	81J	0.85	R/W	AVSS	FLASHER_TURN_L	336B	1.25	P	AVSS	BEACON_RELAY	ZM31	0.5	B	AVSS	GND
39	3	R	AEXF	ELECTRIC_FAN_MOTOR_POWER	82	0.85	L/B	AVSS	Horn signal	337	0.5	G	AVSS	FASTEN_BELT_SWITCH	ZM32	2	B	AVSS	GND
40	0.5	W	AVSS	ALTERNATOR_P_SIGNAL	82A	0.85	L/B	AVSS	Horn signal	338	1.25	L	AVSS	BEACON_LAMP	ZM33	0.85	B	AVSS	GND
41	3	L	AEXF	Start_M/S Signal	82B	0.5	L/B	AVSS	HORN_DIODE	339	0.5	Gr	AVSS	BEACON_SW-RELAY	ZM34	0.5	B	AVSS	HORN_DIODE_GND
43	2	R/B	AVSS	POWER_OUTLET_POWER	83	1.25	Lg	AVSS	HORN_FLASHER_POWER	344	0.5	R/W	AVSS	BRAKE_LAMP_SWITCH	ZM35	0.5	B	AVSS	HORN_SWITCH_GND
44	0.85	R/W	AVSS	Stop_lamp_Signal	83A	1.25	Lg	AVSS	Flasher power(B+ 15A)	363	1.25	R/B	AVSS	FOG_LAMPS(OPTION)POWER	ZM40	0.5	B	AVSS	BRAKE_OIL_SWITCH_GND
44A	0.5	R/W	AVSS	BRAKE_LAMP_L	83B	0.85	Lg	AVSS	HORN POWER	364	0.85	Gr	AVSS	WORK_LAMPS(OPTION)POWER	ZM43	0.85	B	AVSS	IGN_RELAY_COIL_GND
44B	0.5	R/W	AVSS	BRAKE_LAMP_R	83C	0.5	Lg	AVSS	HORN_POWER	364A	0.85	Gr	AVSS	WORK_LAMPS(OPTION)POWER	ZM48	0.5	B	AVSS	WIPER_SWITCH(OPTION)GND
44C	0.5	R/W	AVSS	BRAKE_LAMP2_L(OPTION)	83D	0.85	Lg	AVSS	HAZARD_SW	364B	0.85	Gr	AVSS	WORK_LAMPS(OPTION)POWER	ZM49	1.25	B	AVSS	WIPER_MOTOR(OPTION)GND
47	0.5	W/L	AVSS		83E	1.25	Lg	AVSS	Flasher power(B+ 15A)	404	0.85	R/G	AVSS	ROOM LAMP POWER	ZM50	2	B	AVSS	WIPER/WASHER_MOTOR(OPTION)GND
50	1.25	Y/L	AVSS	FOG_LAMPS(OPTION)	84	0.85	W/R	AVSS	Turn Signal LH	417	2	R/B	AVSS	WIPER/WASHER_MOTOR(OPTION)POWER	ZM51	0.5	B	AVSS	WASHER_SWITCH(OPTION)GND
50A	1.25	Y/L	AVSS	FOG_LAMP_LEFT(OPTION)	85	0.5	B/G	AVSS	REVERSE_SWITCH(OPTION)	375	8	R	AEXF	IGN_OPTION_POWER	ZM52	0.5	B	AVSS	LECNSE_LAMP_RIGHT_GND
50B	0.85	Y/L	AVSS	FOG_LAMP_RIGHT(OPTION)	85A	0.5	B/G	AVSS	REVERSE_SWITCH(OPTION)	375A	5	R	AEXF	IGN_OPTION_POWER	ZM55	1.25	B	AVSS	HEATER(OPTION)GND
50C	0.5	Y/L	AVSS	FOG_LAMP	85B	0.5	B/G	AVSS	REVERSE_SWITCH(OPTION)	375C	1.25	R	AVSS	IGN_OPTION_POWER	ZM57	0.5	B	AVSS	REVERSE_LAMP/BUZZER/DUMP_LIMIT_BUZZER(OPTION)GND
53	0.5	L	AVSS	WORK_LAMPS(OPTION)SWITCH	91	0.85	W	AVSS	HEADLAMP LOW	404	0.85	R/G	AVSS	ROOM LAMP POWER	ZM58	0.5	B	AVSS	REVERSE_LAMP/BUZZER/DUMP_LIMIT_BUZZER(OPTION)GND
55	0.85	G/L	AVSS	WORK_LAMPS(OPTION)	91A	0.85	W	AVSS	LOW_BEAM_LEFT	417	2	R/B	AVSS	WIPER/WASHER_MOTOR(OPTION)POWER	ZM60	0.85	B	AVSS	ROOM_LAMP_GND
55A	0.5	G/L	AVSS	WORK_LAMP_LEFT(OPTION)	91B	0.85	W	AVSS	LOW_BEAM_RIGHT	417A	1.25	R/B	AVSS	WIPER_MOTOR(OPTION)POWER	ZM62	0.5	B	AVSS	BRAKE_LAMP_RELAY_GND
55B	0.5	G/L	AVSS	WORK_LAMP_RIGHT(OPTION)	95	0.85	Br	AVSS	HEADLAMP HIGH	417B	0.5	R/B	AVSS	WASHER_MOTOR(OPTION)POWER	ZM64	0.85	B	AVSS	WIPER_GND
61	0.5	R/Y	AVSS	CLUSTER_POWER	95A	0.85	Br	AVSS	HEADLAMP HIGH	417C	1.25	R/B	AVSS	WIPER_MOTOR(OPTION)POWER	ZM65	0.85	B	AVSS	BEACON_GND
63	0.85	Br	AVSS	POSITION_LAMP_SWITCH	95B	0.85	Br	AVSS	HEADLAMP HIGH	417D	0.5	R/B	AVSS	WIPER_RELAY_COIL(OPTION)POWER	ZM66	0.5	B	AVSS	BEACON_GND
63C	0.5	Br	AVSS	POSITION_LAMPS	95C	0.5	Br	AVSS	HEADLAMP HIGH	418	0.5	Br	AVSS	WASHER_SWITCH(OPTION)	ZM67	1.25	B	AVSS	BEACON_LAMP_GND
63D	0.5	Br	AVSS	POSITION_LAMPS	99	0.85	G	AVSS	Flasher Signal	419	1.25	W	AVSS	WIPER_MOTOR(OPTION)PARK	ZM68	0.85	B	AVSS	BEACON_GND
63E	0.5	Br	AVSS	TURN_SIGNAL_LH_OPTION	102	0.85	R	AVSS	VR_ACTUATOR_POWER(102,103TWIST)	420	1.25	G	AVSS	WIPER_MOTOR(OPTION)COM	ZM75	0.5	B	AVSS	CLUSTER_GND_B_2
63F	0.5	Br	AVSS	POSITION_LH_OPTION	103	0.85	B/R	AVSS	VR_ACTUATOR_OUTPUT(102,103TWIST)	422	0.5	G/B	AVSS	WIPER_SWITCH(OPTION)	ZP3	1.25	B	AVSS	GND
63G	0.5	Br	AVSS	POSITION_LAMPS	132	0.5	B/R	AVSS	GLOW_SIGNAL	507	1.25	R/L	AVSS	HEATER(OPTION)POWER					
63H	0.5	Br	AVSS	POSITION_LAMPS	133	0.5	P/B	AVSS	CEL_LAMP(-)	Z99	0.5	B	AVSS	TACHO GND					

K24WC07A

K9 2400 - EU

- SAFETY/FIRST
- GENERAL
- ENGINE
- CVT
- TRANSMISSION
- CHASSIS
- REAR AXLE
- BRAKE
- FRONT AXLE
- STEERING
- HYDRAULIC
- ELECTRIC
- INDEX

No.	Wiring spec.		Signal Name	
1	AEXF 3.0	B	GND	
	AVSS 2.0			
	AVSS 1.25			
	AVSS 0.85			
	AVSS 0.5			
2	AEXF 5.0	R	B+ Power	
3	AEXF 3.0	R	Starter motor magnet switch	
4	AEXF 5.0	BR	Glow relay power	
5	AVSS 0.5	LY	Start switch ST signal	
6	AVSS 0.5	BY	Neutral diode	
7	AEXF 8.0	R	Glow relay	
			Power join position 1	
			Alternator B	
	AEXF 3.0		Electric fan power	
			Start relay	
			Start switch (B+)	
			Fuel solenoid fuse	
			Horn fuse	
	AVSS 2.0		Instrument panel B+	
			AVSS 1.25	Neutral switch
				AVSS 0.85
8	AVSS 0.5	BL	Display unit (Brake oil)	
9	AVSS 0.5	GB	Display unit (Brake oil)	
10	AVSS 0.5	RW	Alternator power	
11	AVSS 0.5	P	Alternator charge signal	
12	AVSS 0.5	PB	Alternator charge lamp	
13	AVSS 0.5	WY	Speed sensor output	
14	AVSS 2.0	L	Engine stop solenoid (PULL coil)	
	AVSS 0.85		Diode	
15	AVSS 0.5	RL	Engine stop solenoid (HOLD coil)	
16	AVSS 0.5	LB	Display unit (Parking lamp)	
18	AVSS 2.0	LR	Engine stop relay (+)	
20	AVSS 0.5	LW	Engine stop relay coil (-)	
21	AVSS 0.5	Br	Start switch (Glow)	
23	AVSS 0.5	Lg	Temp. switch (Glow)	
25	AVSS 0.5	WB	Temp. sensor	
29	AVSS 0.5	RG	Glow relay coil signal (+)	
32	AVSS 0.85	YG	Brake switch power	
			Brake lamp relay	

No.	Wiring spec.		Signal Name
33	AVSS 0.85	RB	Display unit power
	AVSS 0.5		Fan motor relay
			Pull coil relay
			Brake switch
			Seat switch
			Brake oil switch
34	AVSS 0.5	Gr	Glow lamp
35	AVSS 0.5	YW	Speed signal sensor input
36	AVSS 0.5	WB	HORN coil signal
37	AVSS 0.5	BW	Electric fan coil (-)
39	AEXF 3.0	R	Electric fan Power (+)
40	AVSS 0.5	W	RPM signal input
41	AEXF 3.0	L	Electric fan relay power
43	AVSS 0.85	RB	Power socket
44	AVSS 0.85	RW	7pin socket (Brake lamp)
	AVSS 0.5		Brake lamp Power
47	AVSS 0.5	WL	Fog lamp switch
50	AVSS 1.25	YL	Fog lamp Power (LH)
	AVSS 0.85		Fog lamp Power (RH)
	AVSS 0.5		Instrument panel (Fog lamp)
53	AVSS 0.5	L	Work lamp switch
55	AVSS 0.5	GL	Work lamp power
			Work lamp (LH)
61	AVSS 0.5	RY	Instrument cluster power
63	AVSS 0.85	Br	7pin socket (2 EA)
	AVSS 0.5		Head lamp (RH)
			Head lamp (LH)
			Hazard warning lamp switch
			Fog lamp switch
			Work lamp switch
			Wiper/Washer switch
			Fog lamp relay
			Instrument panel (Position lamp)
			License lamp (LH)
			Rear combi lamp (LH)
			Rear combi lamp (RH)
			Display unit (Parking brake)
			70

No.	Wiring spec.		Signal Name
71	AVSS 0.5	Gr	Engine oil pressure warning lamp
72	AVSS 0.5	YB	Fuel gauge sensor
74	AVSS 1.25	RB	Start switch ACC
75	AEXF 3.0	RW	Ignition switch ON
	AVSS 1.25		Ignition switch ON
	AVSS 0.85		Power relay
76	AVSS 1.25	RY	Head lamp power
	AVSS 0.85		Head lamp (Low beam) relay
77	AVSS 0.5	WR	Head lamp (High beam) relay
			Head lamp (Low beam) relay coil power
78	AVSS 0.5	BrR	Head lamp (High beam) relay coil power
			7pin socket (Turn signal lamp (RH))
80	AVSS 0.85	GW	Turn signal lamp (RH)
	AVSS 0.5		Turn signal lamp (RH)
81	AVSS 0.85	WR	7pin socket (Turn signal lamp (LH))
	AVSS 0.5		Turn signal lamp (LH)
82	AVSS 0.85	LB	Horn signal
	AVSS 0.5		Diode
83	AVSS 1.25	Lg	Horn power
	AVSS 0.85		Flasher unit
	AVSS 0.5		Horn relay coil
85	AVSS 0.5	BG	Reverse buzzer relay
			Instrument panel
91	AVSS 0.85	W	Head lamp (Low beam) (RH)
			Head lamp (Low beam) (LH)
95	AVSS 0.85	Br	Head lamp (High beam) (RH)
	AVSS 0.5		Head lamp (High beam) (LH)
99	AVSS 0.85	G	Instrument panel
			Combination switch
230	AVSS 0.5	Br	Hazard lamp switch (2 EA)
			Start (Brake signal)
231	AVSS 0.5	RY	Display unit
302	AEXF 5.0	R	Option power
303	AEXF 8.0	R	Power relay
	AVSS 0.85		Room lamp

No.	Wiring spec.		Signal Name
305	AVSS 0.5	RY	Display unit (Start signal)
307	AVSS 0.5	RL	Display unit (Seat switch)
310	AVSS 0.5	YL	Speed sensor input
333	AVSS 0.5	RL	Display unit (Parking buzzer)
334	AVSS 0.5	RG	Reverse relay (2 EA)
335	AVSS 0.5	GY	Reverse driving buzzer
344	AVSS 0.5	RW	Brake switch
363	AVSS 1.25	R/B	Fog lamp relay
364	AVSS 0.85	Gr	Work lamp relay
	AVSS 0.5		Work lamp switch
375	AEXF 8.0	R	Power join position 2
	AEXF 3.0		Power relay
	AVSS 2.0		Power relay (2 EA)
404	AVSS 0.85	RG	Room lamp
417	AVSS 2.0	RB	Wiper power
	AVSS 1.25		Wiper relay switch
	AVSS 0.5		Washer motor
418	AVSS 0.5	Br	Washer/Wiper coil
			Washer motor
419	AVSS 1.25	W	Washer motor switch
420	AVSS 1.25	G	Wiper motor
422	AVSS 0.5	GB	Wiper/Washer switch
507	AVSS 1.25	RL	Heater power
599	AVSS 0.85	B	Display unit GND
600	AVSS 0.5	B	Instrument panel GND
601	AVSS 0.5	B	Instrument panel GND
602	AVSS 0.5	B	Instrument panel GND

K24WC09A

K9 2400D - AU

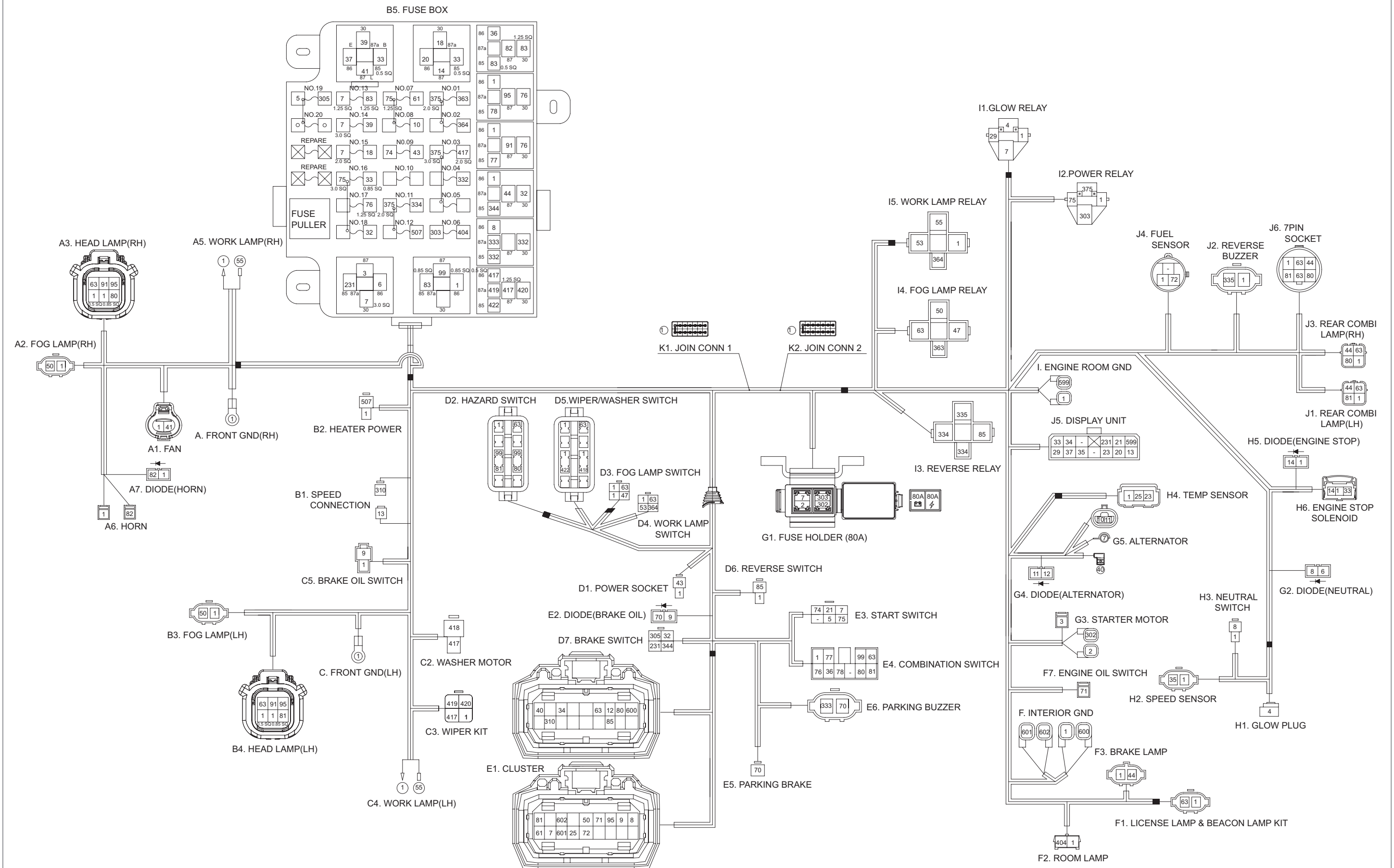

SAFETY FIRST

GENERAL

ENGINE

CVT

TRANSMISSION

CHASSIS

REAR AXLE

BRAKE

FRONT AXLE

STEERING

HYDRAULIC

ELECTRIC

INDEX

K9 2400D - AU

No.	Wiring spec.	Signal Name	
1	AEXF 3.0	GND	
	AVSS 2.0		
	AVSS 1.25		
	AVSS 0.85		
2	AEXF 5.0 R	B+ Power	
3	AEXF 3.0 R	Starter motor magnet switch	
4	AEXF 5.0 BR	Glow relay power	
5	AVSS 0.5 LY	Start switch ST signal	
6	AVSS 0.5 BY	Start relay coil power	
7	AEXF 8.0	Glow relay	
		Power join position 1	
		Alternator B	
	AEXF 3.0	R	Electric fan power
		Start relay	
		Start switch(B+)	
		Fuel solenoid fuse	
	AVSS 2.0	R	Horn fuse
			Instrument panel B+
			Instrument panel (N)
AVSS 0.5	BL	Fusebox (Parking buzzer relay)	
		Instrument panel (N)	
9	AVSS 0.5 GB	Instrument panel (Brake oil warning)	
		Brake oil warning signal	
10	AVSS 0.5 RW	Alternator power	
11	AVSS 0.5 P	Alternator power	
12	AVSS 0.5 PB	Alternator charge lamp	
13	AVSS 0.5 WY	Speed sensor output	
14	AVSS 2.0	Engine stop solenoid (PULL)	
	AVSS 0.85	Diode	
18	AVSS 2.0 LR	Engine stop relay (+)	
20	AVSS 0.5 LW	Engine stop relay coil (-)	
21	AVSS 0.5 Br	Start switch (Glow)	
23	AVSS 0.5 Lg	Temp. switch (Glow)	
25	AVSS 0.5 WB	Temp. sensor	
29	AVSS 0.5 RG	Glow relay coil signal (+)	

No.	Wiring spec.	Signal Name	
32	AVSS 0.85 YG	Brake switch power	
		Brake lamp relay	
33	AVSS 0.85	Display unit power	
		Engine stop solenoid	
	AVSS 0.5	RB	Fan motor relay
		Pull coil relay	
34	AVSS 0.5 Gr	Glow lamp	
35	AVSS 0.5 YW	Speed signal sensor input	
36	AVSS 0.5 WB	HORN coil signal	
37	AVSS 0.5 BW	Electric fan coil (-)	
39	AEXF 3.0 R	Electric fan power (+)	
40	AVSS 0.5 W	RPM signal input	
41	AEXF 3.0 L	Electric fan relay power	
43	AVSS 0.85 RB	Power socket	
44	AVSS 0.85	RW	7pin socket
	AVSS 0.5	Brake lamp power	
47	AVSS 0.5 WL	Fog lamp switch	
50	AVSS 1.25	YL	Fog lamp power (LH)
	AVSS 0.85	Fog lamp power (RH)	
	AVSS 0.5	Instrument panel (Fog lamp)	
53	AVSS 0.5 L	Work lamp switch	
55	AVSS 0.5 GL	Work lamp power	
		Work lamp (LH)	
63	AVSS 0.85	RY	Instrument cluster power
		7pin socket (2 EA)	
		Head lamp (RH)	
		Head lamp (LH)	
		Hazard warning lamp switch	
		Fog lamp switch	
		Work lamp switch	
		Wiper/Washer switch	
		Fog lamp relay	
		Instrument panel (Position lamp)	
		License lamp (LH)	
		Rear combi lamp (LH)	
		Rear combi lamp (RH)	

No.	Wiring spec.	Signal Name	
70	AVSS 0.5 W	Diode	
		Parking buzzer	
71	AVSS 0.5 Gr	Engine oil pressure warning lamp	
72	AVSS 0.5 YB	Fuel gauge sensor	
74	AVSS 1.25 RB	Start switch ACC	
75	AEXF 3.0	RW	Ignition switch ON
	AVSS 1.25		Ignition switch ON
	AVSS 0.85		Power relay
76	AVSS 1.25	RY	Head lamp power
	AVSS 0.85		Head lamp (Low beam) relay
77	AVSS 0.5 WR	Head lamp (High beam) relay	
		Head lamp (Low beam) relay coil power	
78	AVSS 0.5 BrR	Head lamp (High beam) relay coil power	
		7pin socket	
80	AVSS 0.85	GW	Turn signal lamp (RH)
			7pin socket
			Turn signal lamp (LH)
81	AVSS 0.85	WR	7pin socket
	AVSS 0.5		Turn signal lamp (LH)
82	AVSS 0.85	LB	Horn signal
	AVSS 0.5		Diode
83	AVSS 1.25	Lg	Horn power
	AVSS 0.85		Flasher unit
	AVSS 0.5		Horn relay coil
85	AVSS 0.5 BG	Reverse buzzer relay	
		Instrument panel	
91	AVSS 0.85 W	Head lamp (Low beam) (RH)	
		Head lamp (Low beam) (LH)	
95	AVSS 0.85	Br	Head lamp (High beam) (RH)
	AVSS 0.5		Head lamp (High beam) (LH)
99	AVSS 0.85 G	Instrument panel	
		Combination switch	
231	AVSS 0.5 RY	Hazard lamp switch (2 EA)	
		Start (Brake signal)	
			Display unit (ST signal)

No.	Wiring spec.	Signal Name	
302	AEXF 5.0 R	Option power	
303	AEXF 8.0	R	Power relay
	AVSS 0.85		Room lamp
305	AVSS 0.5 RY	Brake start power	
310	AVSS 0.5 YL	Speed sensor input	
332	AVSS 0.5 RG	Parking buzzer relay (3 EA)	
333	AVSS 0.5 RL	Parking buzzer	
334	AVSS 0.5 RG	Reverse relay (2 EA)	
335	AVSS 0.5 GY	Reverse driving buzzer	
344	AVSS 0.5 RW	Brake switch	
363	AVSS 1.25 R/B	Fog lamp relay	
364	AVSS 0.85	Gr	Work lamp relay
	AVSS 0.5		Work lamp switch
375	AEXF 8.0	R	Power join position 2
	AEXF 3.0		Power relay
	AVSS 2.0		Power relay (2 EA)
404	AVSS 0.85 RG	Room lamp	
417	AVSS 2.0	RB	Wiper power
	AVSS 1.25		Wiper relay switch
	AVSS 0.5		Washer motor
			Washer/Wiper coil
418	AVSS 0.5 Br	Washer motor	
419	AVSS 1.25 W	Washer motor switch	
420	AVSS 1.25 G	Wiper motor	
422	AVSS 0.5 GB	Wiper/Washer switch	
507	AVSS 1.25 RL	Heater power	
599	AVSS 0.85 B	Display unit GND	
600	AVSS 0.5 B	Instrument panel GND	
601	AVSS 0.5 B	Instrument panel GND	
602	AVSS 0.5 B	Instrument panel GND	

K24WC11A

K9 2440D - AU

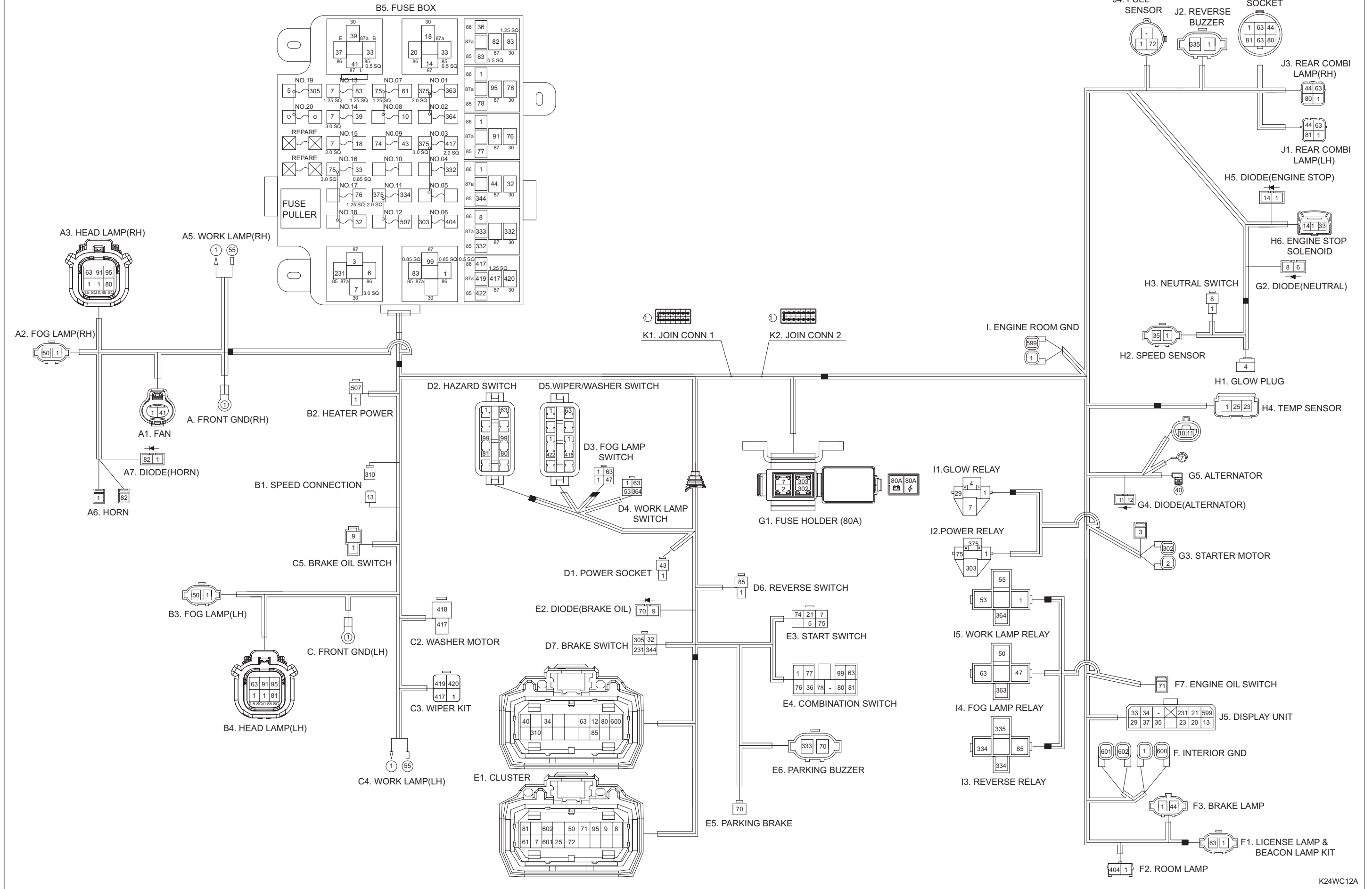

- SAFETY FIRST
- GENERAL
- ENGINE
- CVT
- TRANSMISSION
- CHASSIS
- REAR AXLE
- BRAKE
- FRONT AXLE
- STEERING
- HYDRAULIC
- ELECTRIC**
- INDEX

K9 2440D - AU

No.	Wiring spec.		Signal Name	
1	AEXF 3.0	B	GND	
	AVSS 2.0			
	AVSS 1.25			
	AVSS 0.85			
2	AEXF 5.0	R	B+ Power	
3	AEXF 3.0	R	Starter motor magnet switch	
4	AEXF 5.0	BR	Glow relay power	
5	AVSS 0.5	LY	Start switch ST signal	
6	AVSS 0.5	BY	Start relay coil power	
7	AEXF 8.0	R	Glow relay	
			Power join position 1	
			Alternator B	
	AEXF 3.0		Electric fan power	
			Start relay	
			Start switch(B+)	
			Fuel solenoid fuse	
	AVSS 2.0		Horn fuse	
			AVSS 1.25	Instrument panel B+
				AVSS 0.85
8	AVSS 0.5	BL	Neutral switch signal	
			Instrument panel (N)	
			Fusebox (Parking buzzer relay)	
9	AVSS 0.5	GB	Instrument panel (Brake oil warning)	
			Brake oil warning signal	
10	AVSS 0.5	RW	Alternator power	
11	AVSS 0.5	P	Alternator power	
12	AVSS 0.5	PB	Alternator charge lamp	
13	AVSS 0.5	WY	Speed sensor output	
14	AVSS 2.0	L	Engine stop solenoid (PULL coil)	
	AVSS 0.85		Diode	
18	AVSS 2.0	LR	Engine stop relay (+)	
20	AVSS 0.5	LW	Engine stop relay coil (-)	
21	AVSS 0.5	Br	Start switch (Glow)	
23	AVSS 0.5	Lg	Temp. switch (Glow)	
25	AVSS 0.5	WB	Temp. sensor	
29	AVSS 0.5	RG	Glow relay coil signal (+)	

No.	Wiring spec.		Signal Name
32	AVSS 0.85	YG	Brake switch power
			Brake lamp relay
33	AVSS 0.85	RB	Display unit power
			Engine stop solenoid
	AVSS 0.5		Fan motor relay
			Pull coil relay
34	AVSS 0.5	Gr	Glow lamp
35	AVSS 0.5	YW	Speed signal sensor input
36	AVSS 0.5	WB	HORN coil signal
37	AVSS 0.5	BW	Electric fan coil (-)
39	AEXF 3.0	R	Electric fan power (+)
40	AVSS 0.5	W	RPM signal input
41	AEXF 3.0	L	Electric fan relay power
43	AVSS 0.85	RB	Power socket
44	AVSS 0.85	RW	7pin socket
	AVSS 0.5		Brake lamp power
47	AVSS 0.5	WL	Fog lamp switch
50	AVSS 1.25	YL	Fog lamp power (LH)
	AVSS 0.85		Fog lamp power (RH)
	AVSS 0.5		Instrument panel (Fog lamp)
53	AVSS 0.5	L	Work lamp switch
55	AVSS 0.5	GL	Work lamp power
			Work lamp (LH)
61	AVSS 0.5	RY	Instrument cluster power
63	AVSS 0.5	Br	7pin socket (2 EA)
			Head lamp (RH)
			Head lamp (LH)
			Hazard warning lamp switch
			Fog lamp switch
			Work lamp switch
			Wiper/Washer switch
			Fog lamp relay
			Instrument panel (Position lamp)
			License lamp (LH)
			Rear combi lamp (LH)
			Rear combi lamp (RH)

No.	Wiring spec.		Signal Name
70	AVSS 0.5	W	Diode
			Parking buzzer
71	AVSS 0.5	Gr	Engine oil pressure warning lamp
72	AVSS 0.5	YB	Fuel gauge sensor
74	AVSS 1.25	RB	Start switch ACC
75	AEXF 3.0	RW	Ignition switch ON
	AVSS 1.25		Ignition switch ON
	AVSS 0.85		Power relay
76	AVSS 1.25	RY	Head lamp power
	AVSS 0.85		Head lamp (Low beam) relay
			Head lamp (High beam) relay
77	AVSS 0.5	WR	Head lamp (Low beam) relay coil power
78	AVSS 0.5	BrR	Head lamp (High beam) relay coil power
80	AVSS 0.85	GW	7pin socket
			Turn signal lamp (RH)
			AVSS 0.5
81	AVSS 0.85	WR	7pin socket
			Turn signal lamp (LH)
82	AVSS 0.85	LB	Horn signal
	AVSS 0.5		Diode
83	AVSS 1.25	Lg	Horn power
	AVSS 0.85		Flasher unit
	AVSS 0.5		Horn relay coil
85	AVSS 0.5	BG	Reverse buzzer relay
			Instrument panel
91	AVSS 0.85	W	Head lamp (Low beam) (RH)
			Head lamp (Low beam) (LH)
95	AVSS 0.85	Br	Head lamp (High beam) (RH)
	AVSS 0.5		Head lamp (High beam) (LH)
99	AVSS 0.85	G	Instrument panel
			Combination switch
231	AVSS 0.5	RY	Hazard lamp switch (2 EA)
			Start (Brake signal)
302	AEXF 5.0	R	Display unit (ST signal)
			Option power

No.	Wiring spec.		Signal Name
303	AEXF 8.0	R	Power relay
	AVSS 0.85		Room lamp
305	AVSS 0.5	RY	Brake start power
310	AVSS 0.5	YL	Speed sensor input
332	AVSS 0.5	RG	Parking buzzer relay (3 EA)
333	AVSS 0.5	RL	Parking buzzer
334	AVSS 0.5	RG	Reverse relay (2 EA)
335	AVSS 0.5	GY	Reverse driving buzzer
344	AVSS 0.5	RW	Brake switch
363	AVSS 1.25	R/B	Fog lamp relay
364	AVSS 0.85	Gr	Work lamp relay
	AVSS 0.5		Work lamp switch
375	AEXF 8.0	R	Power join position 2
	AEXF 3.0		Power relay
	AVSS 2.0		Power relay (2 EA)
404	AVSS 0.85	RG	Room lamp
417	AVSS 2.0	RB	Wiper power
	AVSS 1.25		Wiper relay switch
	AVSS 0.5		Washer motor
418	AVSS 0.5	Br	Washer/Wiper coil
			Washer motor
419	AVSS 1.25	W	Washer motor switch
420	AVSS 1.25	G	Wiper motor
422	AVSS 0.5	GB	Wiper/Washer switch
507	AVSS 1.25	RL	Heater power
599	AVSS 0.85	B	Display unit GND
600	AVSS 0.5	B	Instrument panel GND
601	AVSS 0.5	B	Instrument panel GND
602	AVSS 0.5	B	Instrument panel GND

K24WC13A

7. DIAGNOSIS AND TROUBLESHOOTING

7.1 GENERAL TROUBLESHOOTING

7.1.1 BATTERY



M24WC39A

This vehicle is equipped with 12 V battery with minimum cold cranking ability of 630 A at -18°C.

The battery is located in the middle fender on the left side of the seat. It should be firmly fixed with no corrosion.

If needed, clean the battery surface with baking soda and water and be careful not to get undistilled water into the battery.

After cleaning, rinse the battery and apply a small amount of grease to prevent the terminals from corroding.

The battery should maintain its charging status even at the freezing point. If the battery is discharged or the battery fluid is insufficient, the electrolyte may be diluted or frozen. This may lead to damage to the case.

● CAUSES OF BATTERY EXPIRATION

The causes for battery failure can be divided into the following three causes:

1. Overly discharged

The specific gravity of electrolyte is too low and the terminal voltage is not measurable.

Cause

- Self-discharge:
If the battery is left unused for 2 ~ 3 months, it will fully discharge.
- Closed circuit (battery surface):
Due to the electrolyte or water on the battery cover, a closed circuit is formed between the positive and the negative terminals and, consequently, the battery will fully discharge.

2. Over charging

If the battery is charged for over the specified time, the electrolyte's temperature rises and the amount of electrolyte decreases.

(If this happens frequently, the battery life is shortened.)

3. Battery life

If the charged and discharged conditions are repeated, the amount of activated material and the specific gravity decrease due to the chemical reaction among the positive terminal, negative terminal and electrolyte.

SAFETY FIRST

GENERAL

ENGINE

CVT

TRANSMISSION

CHASSIS

REAR AXLE

BRAKE

FRONT AXLE

STEERING

HYDRAULIC

ELECTRIC

INDEX

7.1.2 WIRING

The negative battery cable should be disconnected if there is any possibility of short circuit when installing or removing the wiring and electric components.

When disengaging the connectors, press both connector locks firmly to disengage them.

Refer to the below figures for disconnecting and connecting the battery terminals.

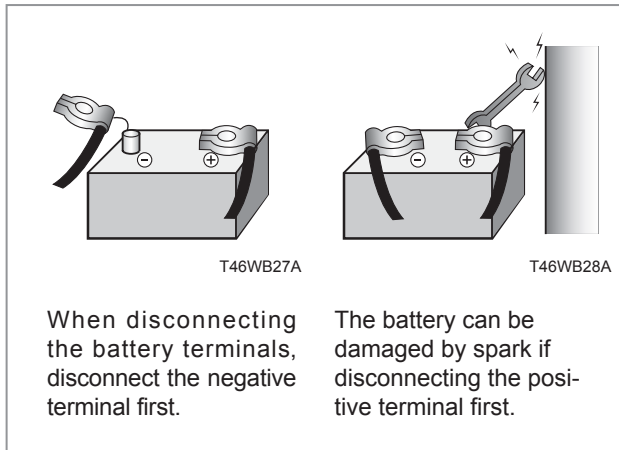

- When disconnecting the battery terminals, disconnect the negative terminal first.

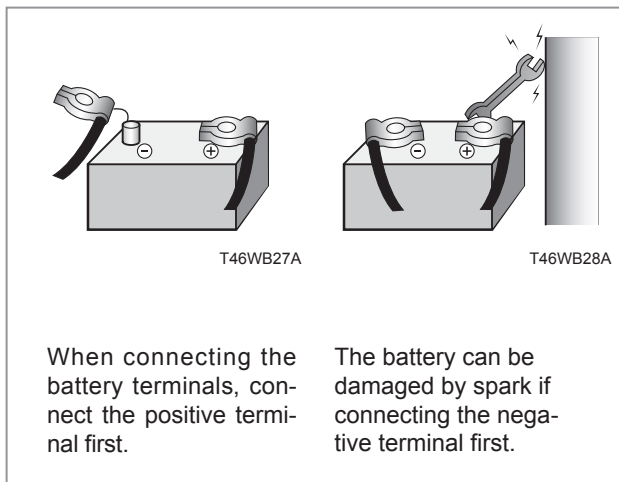

- When connecting the battery terminals, connect the positive terminal first.

● CAUSES FOR BLOWN FUSE

There are three causes for blown fuse which can be inspected after blown.

1. Over-current due to a short circuit
Can occur due to mechanical fault or electrical fault. For example, high current is applied to the motor if the wiper blades are frozen on the windshield.
(The cause of blown fuse should be determined before replacing the fuse.)
2. Aged fuse
As current is cycled through fuses from ON to OFF repeatedly, the fuse's temperature rises and drops and it is eventually blown. If the fuse is blown, replace it immediately.
3. Poor contact (heat produced)
If the fuse is poorly seated, the fuse will blow due to the heat by resistance. Polish the fuse contact surface with sandpaper to prevent this problem.

● CHECKING CIRCUITS

In general, it is not hard to inspect an electric circuit in a logical and organized way. It is very important to collect as much information as possible before starting inspection. Also, you should understand the system's operation and be ready to follow proper inspection procedures using proper devices.

If necessary, the inspector can shake wiring or electric parts gently while testing them.

- Open circuit: There is a disconnected part in a circuit.
- Short circuit: There are two types of short circuit.
 - Short to circuit:
The resistance changes as a circuit is contacted to another circuit.
 - Short to ground:
A circuit is contacted to ground or ground part.

• GROUND TEST

The ground connection is critical for the electric and electronic circuits' operation. It is often exposed to several factors for corrosion such as humidity and dust.

Corrosion produces unnecessary resistance and this resistance can affect the circuit operation. Also, electrically controlled circuit is very sensitive to ground.

If the ground wiring is loose or corroded, it can greatly affect the electrically controlled circuit.

Even though the ground connection seems to be clean, there might be a thin corroded layer on the surface. Perform the following steps for inspecting the ground connection.

1. Remove any ground bolt and clip.
2. Check if there is dirt or corroded layer on the surface.
3. Clean the surface completely for proper connection.
4. Tighten bolts and screws firmly.
5. Check parts related to the ground circuit.

If several wirings are connected to one ground terminal, check for proper connection.

All wirings should be clean, securely tightened and properly grounded. Even the wirings connected to the one ground point should be cleaned before they are reinstalled.

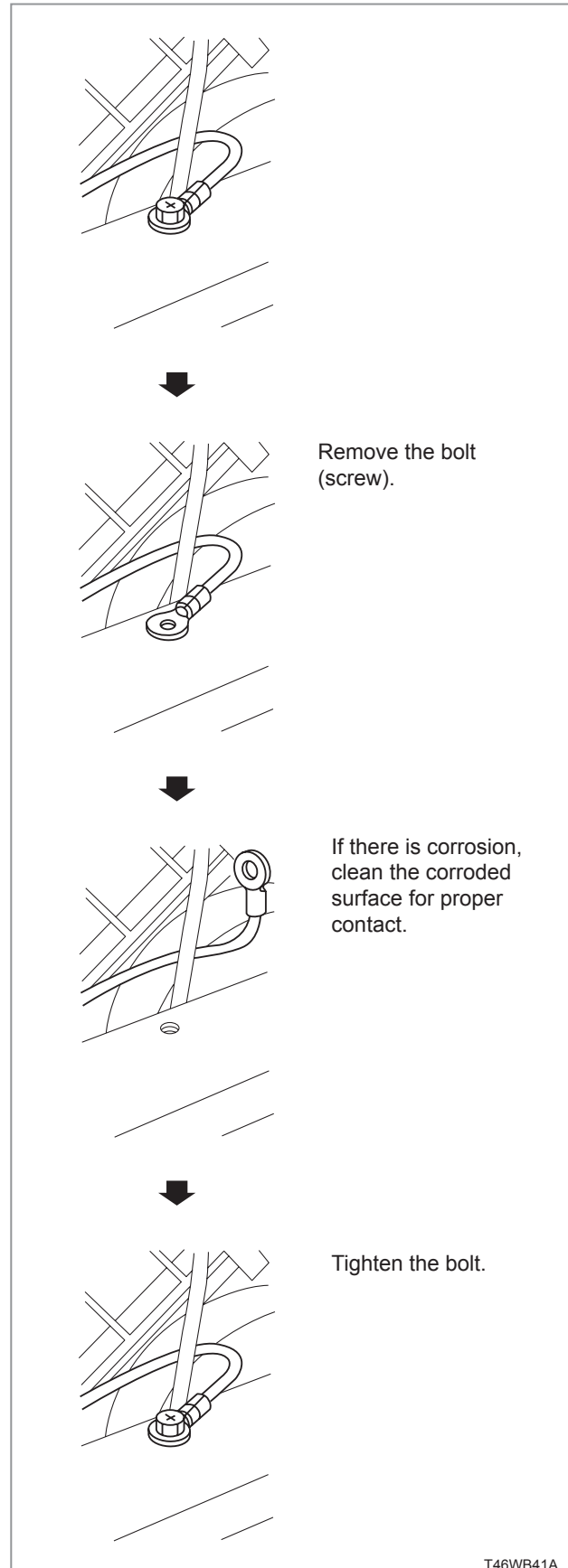

SAFETY FIRST
GENERAL
ENGINE
CVT
TRANSMISSION
CHASSIS
REAR AXLE
BRAKE
FRONT AXLE
STEERING
HYDRAULIC
ELECTRIC
INDEX

7.1.3 GENERAL

● OVERVIEW

Sometime, a problem may be difficult to reproduce.

If this is the case, the conditions during failure may need to be reproduced. The following is how to reproduce conditions that can cause electrical problems.

The electric problems can be divided into the following 6 sections:

- Vibration
- Damage by heat
- Freezing
- Moisture
- Electric load
- Starting in frozen or overheated condition

Check the symptom by asking customer. This is a very important factor when reproducing the symptom.

● VIBRATION

A problem may occur and the tractor's condition can get worse if driving the tractor on unpaved road or the engine vibrates harshly (when running A/C at idling).

In this case, inspect the conditions related to the vibration.

WIRE CONTACT CHECK

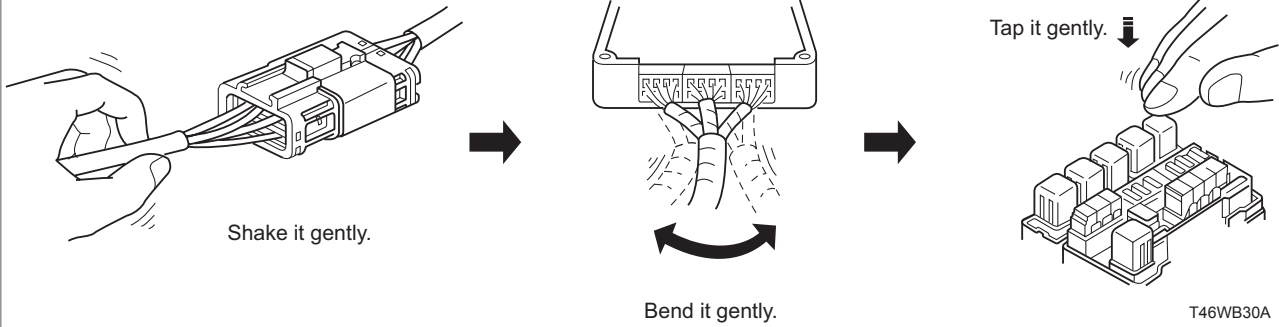

LOOSE PRONG CHECK

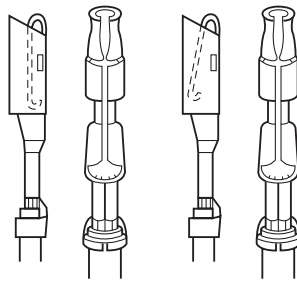

As the connector is installed and removed repeatedly, the aperture of contact spring can be bent.

T46WB31B

WIRE SEIZING CHECK

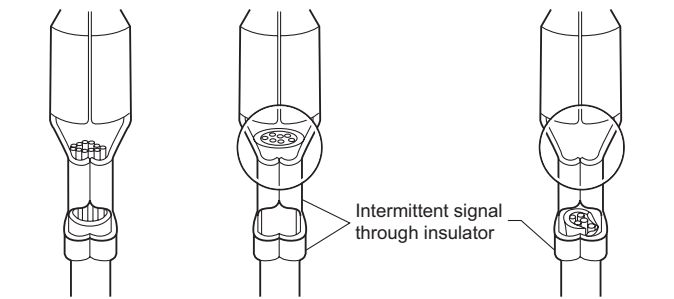

T46WB32A

CONNECTOR CHECK

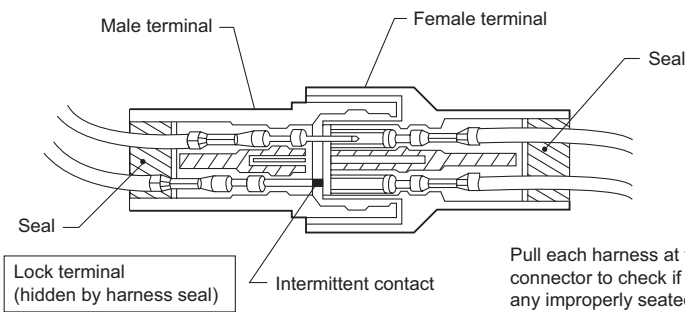

Pull each harness at the end of connector to check if there is any improperly seated terminal.

T46WB33B

Improperly installed connector

SAFETY FIRST
GENERAL
ENGINE
CVT
TRANSMISSION
CHASSIS
REAR AXLE
BRAKE
FRONT AXLE
STEERING
HYDRAULIC
ELECTRIC
INDEX

● **DAMAGE BY HEAT**

If the problem in the tractor occurred in hot weather, the inspector should check the conditions affected by heat. Apply some heat to the parts with a heat gun to determine whether such electric parts are sensitive to heat.

Never let electric parts' temperature rise over 60°C (140 °F).

If a fault occurs while applying the heat, replace the part or insulate it.

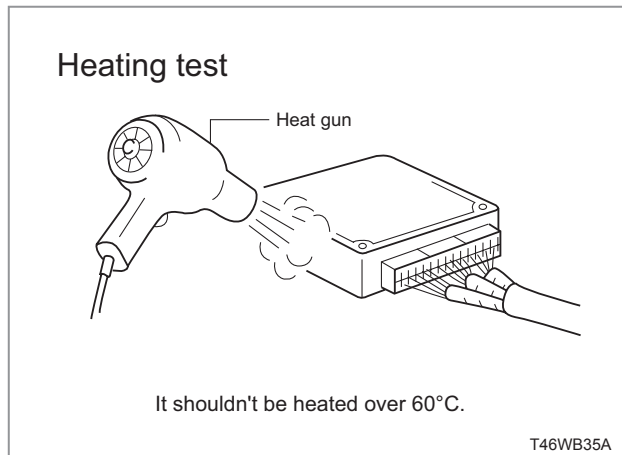

● **FREEZING**

A fault may disappear after warming up the tractor (in cold weather).

In this case, a cause of such fault can be frozen wiring or electric parts. There are two methods to inspect such fault.

The first method is to ask the customer to park the tractor outside for over a night to cool it down and reproduce the symptom and inspect the relevant electric parts rapidly and thoroughly in the following morning.

The second method is to keep the relevant electric parts in a refrigerator for enough time to freeze, reinstall them and check if such fault is occurred again. If it is, repair or replace the corresponding part.

● **FAULT BY MOISTURE**

A fault may occur only in high humidity condition, rainy season or snow. In this case, a fault may occur when water enters into electrical parts.

Never spray water directly on the electric parts to reproduce the symptom.

Inspect the connectors if water enters in it, apply di-electric grease as needed.

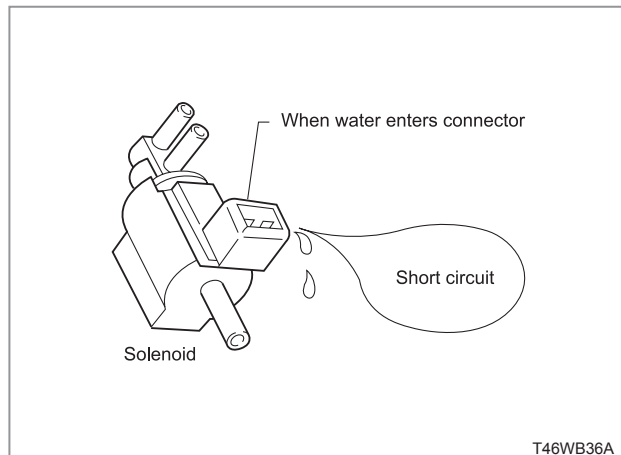

● **ELECTRIC LOAD**

A fault can occur in electric parts due to the reaction to electric load. Perform the inspection while turning on all electric devices (A/C, cigarette lighter, radio, head-lamps, etc.).

● **ENGINE COLD OR HOT CONDITIONS**



An electric fault can occur when the engine is cold or when the engine is hot.

Inspect the tractor after leaving it outdoor over night for cold condition.

Inspect the tractor after run engine for a while for hot condition.

7.2 TROUBLESHOOTING

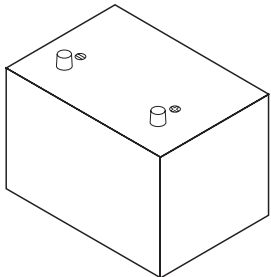
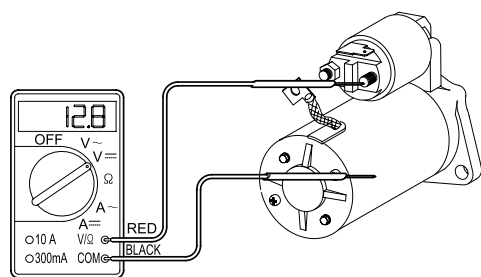
7.2.1 WHEN THE ENGINE CANNOT BE STARTED

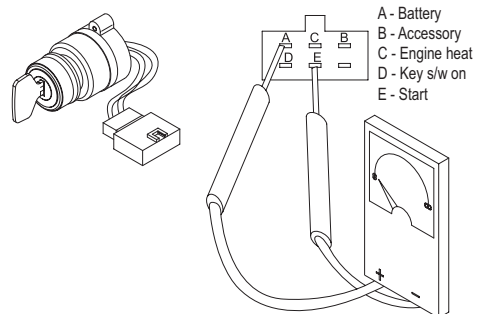
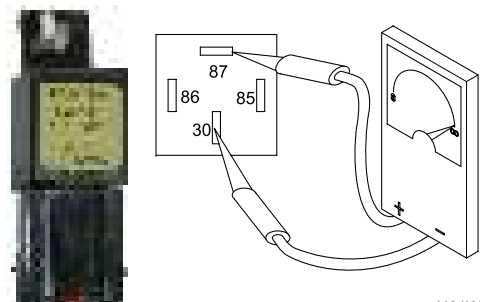
Check point	Check item (method)	Remarks
1. Battery voltage	<ul style="list-style-type: none"> - Measure the voltage between battery (+) and (-) terminals using a tester. - Result: 11.8 ~ 12.9 V <p>However, the voltage may be over this range if it is measured immediately after turning the engine off.</p>	 <p>T46WBB9A</p>
2. Battery terminal of start motor	<ul style="list-style-type: none"> - Proper connection of battery cable - The voltage between M terminal of start motor and chassis should be approximately same to the battery voltage. - Check for corrosion. - Check connection of battery cable. 	 <p>T46WBC0A</p>
3. Slow blow fuse	<ul style="list-style-type: none"> - Check fuse engagement. - Check main fuse for short circuit. Rated capacity: 60 A 	 <p>H61WB33A</p>
4. Key switch	<p>Check for proper connection.</p> <p>"OFF" position: No connection</p> <p>"ACC" position: A-B</p> <p>"ON" position: A-B-D</p> <p>"PREHEAT" position: A-C-D</p> <p>"ST" position: A-D-E</p>	 <p>T46WBC2A</p>
5. Ignition relay, engine stop pull coil relay	<ol style="list-style-type: none"> 1. Connecting the power to No. 85 and 86 terminals: No. 87 and 30 terminals connected 2. Not connecting the power to No. 85 and 86 terminals : No. 87 and 30 terminals open 	 <p>H61WB34A</p>

SAFETY FIRST

GENERAL

ENGINE

CVT

TRANSMISSION

CHASSIS

REAR AXLE

BRAKE

FRONT AXLE

STEERING

HYDRAULIC

ELECTRIC

INDEX

- SAFETY FIRST
- GENERAL
- ENGINE
- CVT
- TRANSMISSION
- CHASSIS
- REAR AXLE
- BRAKE
- FRONT AXLE
- STEERING
- HYDRAULIC
- ELECTRIC**
- INDEX

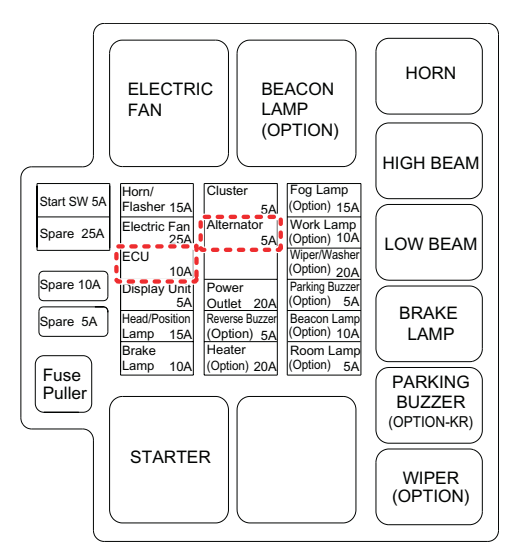
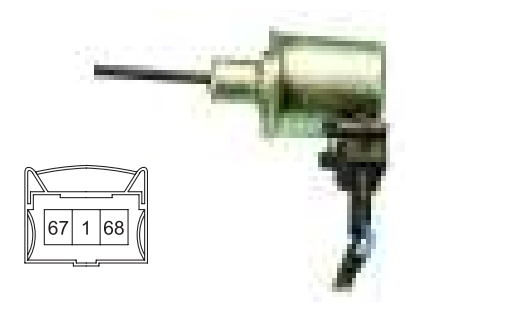
Check point	Check item (method)	Remarks
6. Fuse	<p>K9 2400D - AU, K9 2400 -EU</p> <p>- Check No. 13 and 7 fuses for open circuit. (If it has a open circuit, replace it with new one with rated capacity.)</p> <ul style="list-style-type: none"> ● Fuse 13 : Fuel solenoid (25A) ● Fuse 7 : Alternator (5A) 	 <p>M24WC63A</p>
	<p>K9 2400 SW(GW)</p> <p>- Check No.14 and 8 fuses for open circuit. (If it has a open circuit, replace it with new one with rated capacity.)</p> <ul style="list-style-type: none"> ● Fuse 14 : ECU (10A) ● Fuse 8 : Alternator (5A) 	 <p>K24WC36A</p>
7. Engine stop solenoid	<p>K9 2400D - AU, K9 2400 -EU</p> <ol style="list-style-type: none"> 1. Check the solenoid unit. Measure resistance on both ends of engine stop solenoid. Between No. 68 and ground: Approx. 0.4 Ω Approx. 32 A Between No. 67 and ground: Approx. 13.8 Ω Approx. 0.77 A * Clicking sound should be heard when turning the key switch to the "ON" position. 2. Check the wiring. Voltage between No. 67 and ground when turning key switch to "ON": 12 V Voltage between No. 68 and ground in 1 second after turning key switch to "ON": 12 V (only for 1 sec.) 	 <p>S76WBH3A</p>
8. ECU/Actuator	<p>K9 2400 SW(GW)</p> <ol style="list-style-type: none"> 1. ECU and sensor inspection 	- Refer to "Troubleshooting for fault code" (3-45 page)

7.2.2 WHEN THE SYSTEM IS NOT CHARGED

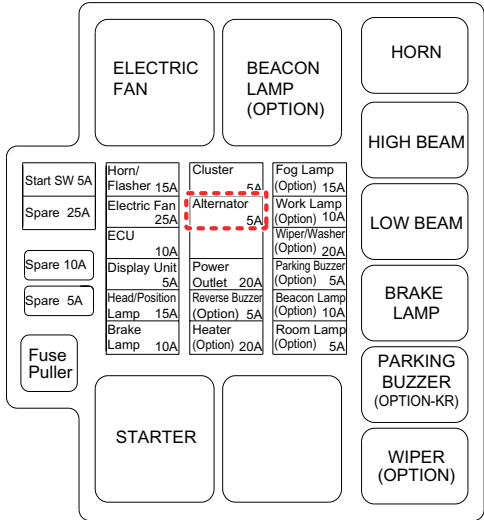
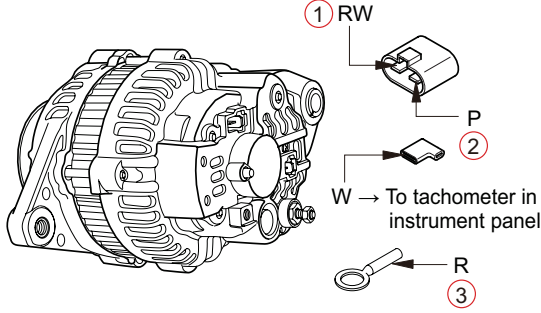



Check point	Check item (method)	Remarks
1. Fuse	<p>K9 2400D - AU, K9 2400 -EU</p> <ul style="list-style-type: none"> - Check the fuse No. 7 for open circuit. (If it has a open circuit, replace it with new one with rated capacity.) ● Fuse 7 : Alternator (5A) 	 <p>M24WC64A</p>
	<p>K9 2400 SW(GW)</p> <ul style="list-style-type: none"> - Check the fuse No. 8 for open circuit. (If it has a open circuit, replace it with new one with rated capacity.) ● Fuse 8 : Alternator (5A) 	 <p>K24WC37A</p>
2. Regulator operating power (with the key switch "ON")	<ul style="list-style-type: none"> - Measure the voltage between No. 1 (RW) of 2P connector and alternator body (ground) with the key switch "ON". Normal: Over 12 V Abnormal: Below 10 V - Measure the voltage between No. 2 (P) of 2P connector and alternator body (ground) with the engine running. Normal: 14.0 ~ 14.7 V Abnormal: Below 12 V 	 <p>M24WC80B</p>

SAFETY FIRST
 GENERAL
 ENGINE
 CVT
 TRANSMISSION
 CHASSIS
 REAR AXLE
 BRAKE
 FRONT AXLE
 STEERING
 HYDRAULIC
ELECTRIC
 INDEX

7.2.3 CHECK THE CHARGE WARNING LAMP FOR MALFUNCTION.

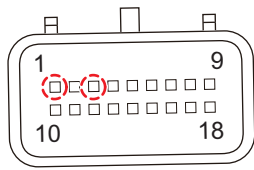
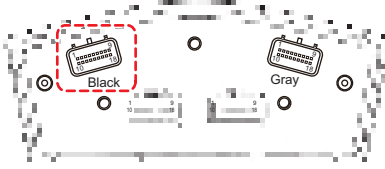
Normal operating condition

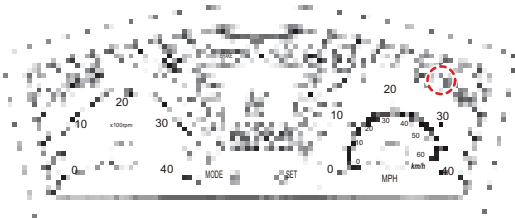
- Before starting the engine (key switch in "ON" position): Charge warning lamp ON
- After starting the engine: Charge warning lamp OFF

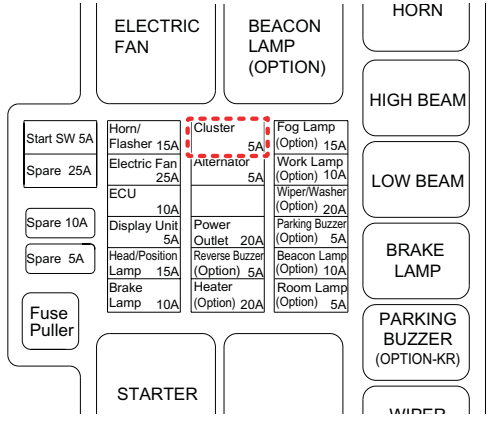
Check point	Check item (method)	Remarks
1. Charge warning lamp (on cluster)	1. Check voltage - The voltage between the Pin B3 of cluster and ground terminal (B1) should be below the battery voltage (approx. 3 V) when the key switch is in "ON" position.	  M24WC46A
2. Charge warning lamp bulb	1. Check if the bulb filament is blown. (visual check)	  M24WC47A
3. Fuse	<p>K9 2400D - AU, K9 2400 -EU</p> <p>1. Check the No. 6 fuse in the fuse box.</p> <ul style="list-style-type: none"> ● Fuse 6 : Cluster (5A) 	 M24WC40A
	<p>K9 2400 SW(GW)</p> <p>1. Check the No. 7 fuse in the fuse box.</p> <ul style="list-style-type: none"> ● Fuse 7 : Cluster (5A) 	 M24WC38A

7.2.4 WHEN THE SYSTEM IS NOT PREHEATED MANUALLY

Check point	Check item (method)	Remarks
1. Preheat relay	<p>1. Connecting 12 V to the No. 85 and 86 terminals with the key "ON" or "G" : No. 87 and 30 terminals connected (closed circuit)</p> <p>2. Not connecting power to No. 85 and 86 terminals : No. 87 and 30 terminals open</p>	<p style="text-align: right;">S76WB17A</p>
2. Glow plug	<p>1. Check if the resistance between the glow plug ring terminal and ground (chassis) is approx. 0.43 Ω.</p> <ul style="list-style-type: none"> - If the measured resistance is "∞": open circuit - If the measured resistance is "0": short circuit <p>2. Check the voltage when in operation.</p> <ul style="list-style-type: none"> - With the plug manually preheated, the voltage between the glow plug and ground should be 12 V. (Voltage fluctuation by operating time: 8 ~ 12 V) 	<p style="text-align: right;">UUVWA72A</p>

SAFETY FIRST
GENERAL
ENGINE
CVT
TRANSMISSION
CHASSIS
REAR AXLE
BRAKE
FRONT AXLE
STEERING
HYDRAULIC
ELECTRIC
INDEX

SAFETY FIRST

GENERAL

ENGINE

CVT

TRANSMISSION

CHASSIS

REAR AXLE

BRAKE

FRONT AXLE

STEERING

HYDRAULIC

ELECTRIC

INDEX

7.2.5 WHEN THE SYSTEM IS NOT PREHEATED AUTOMATICALLY

Check point	Check item (method)	Remarks
1. Check the battery voltage	<ul style="list-style-type: none"> - Measure the voltage between battery (+) and (-) terminals using a tester - Result: 11.8 ~ 12.9 V <p>However, the voltage may be over this range if it is measured immediately after turning the engine off.</p> <ul style="list-style-type: none"> - Continue to the next step. 	<p align="right">T46WBB9A</p>
2. Battery terminal of start motor	<ol style="list-style-type: none"> 1. Proper connection of battery cable <ul style="list-style-type: none"> - The voltage between start motor's M terminal and chassis should be approximately same as the battery voltage. 2. When voltage is not supplied <ul style="list-style-type: none"> - Check proper connection of battery cable - Check the corrosion - Continue to the next step. 	<p align="right">T46WBC0A</p>
3. Slow blow fuse	<ul style="list-style-type: none"> - Fuse engagement - Short circuit of main fuse <p>Rated capacity: 60A</p>	<p align="center">BP 1</p> <p align="right">T46WBC1A</p>
4. Key switch	<p>Check proper connection</p> <p>"ON" position: A-B-D</p> <p>"PREHEAT" position: A-C-D</p>	<p align="right">T46WBC2A</p>
5. Preheat relay	<ol style="list-style-type: none"> 1. With key ON, connect 12 V to No. 85 and 86 terminals : No. 87 and 30 terminals connected (closed circuit) 2. Not connecting 12 V to No. 85 and 86 terminals : No. 87 and 30 terminals open circuit 	<p align="right">T46WBC3A</p>

Check point	Check item (method)	Remarks																					
6. Fuse	<p>K9 2400D - AU, K9 2400 -EU</p> <p>1. Check method</p> <ul style="list-style-type: none"> - Fuse 14 for open circuit - If it has a open circuit, replace it with new one with rated capacity . <ul style="list-style-type: none"> ● Fuse 14 : Display unit (5A) 	<p>M24WC65A</p>																					
	<p>K9 2400 SW(GW)</p> <p>1. Check method</p> <ul style="list-style-type: none"> - Fuse 15 for open circuit - If it has a open circuit, replace it with new one with rated capacity . <ul style="list-style-type: none"> ● Fuse 15 : Display unit (5A) 	<p>K24WC39A</p>																					
7. Display unit	<p>1. Check the following</p> <ul style="list-style-type: none"> - Check if the voltage at the No. 1 terminal is 12 V with the key switch in "ON" position - Check if the output voltage at the AU : No. 7 / EU : No. 3 / US : No. 3 terminal is 12 V with the coolant temperature below 30°C (86°F) - Check if the output voltage between No. 2 terminal and ground is 12 V (for 8 seconds) → Preheat lamp (No. 2) 	<table border="1"> <thead> <tr> <th>No.</th> <th>Signal</th> </tr> </thead> <tbody> <tr> <td>US 3</td> <td>Glow signal(-) input</td> </tr> <tr> <td>EU 3</td> <td>Glow signal input(+)</td> </tr> <tr> <td>AU 7</td> <td>Preheat relay output</td> </tr> </tbody> </table> <p>US/AU</p> <table border="1"> <tr> <td>6</td><td>5</td><td>4</td><td>3</td><td>2</td><td>1</td> </tr> <tr> <td>13</td><td>12</td><td>11</td><td>10</td><td>9</td><td>8</td><td>7</td> </tr> </table> <p>EU</p> <p>K24WC57A</p>	No.	Signal	US 3	Glow signal(-) input	EU 3	Glow signal input(+)	AU 7	Preheat relay output	6	5	4	3	2	1	13	12	11	10	9	8	7
No.	Signal																						
US 3	Glow signal(-) input																						
EU 3	Glow signal input(+)																						
AU 7	Preheat relay output																						
6	5	4	3	2	1																		
13	12	11	10	9	8	7																	

SAFETY FIRST
GENERAL
ENGINE
CVT
TRANSMISSION
CHASSIS
REAR AXLE
BRAKE
FRONT AXLE
STEERING
HYDRAULIC
ELECTRIC
INDEX

- SAFETY FIRST
- GENERAL
- ENGINE
- CVT
- TRANSMISSION
- CHASSIS
- REAR AXLE
- BRAKE
- FRONT AXLE
- STEERING
- HYDRAULIC
- ELECTRIC**
- INDEX

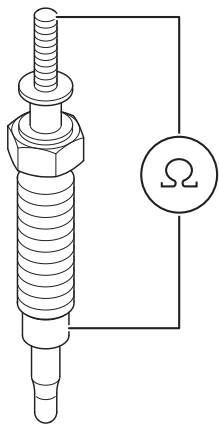
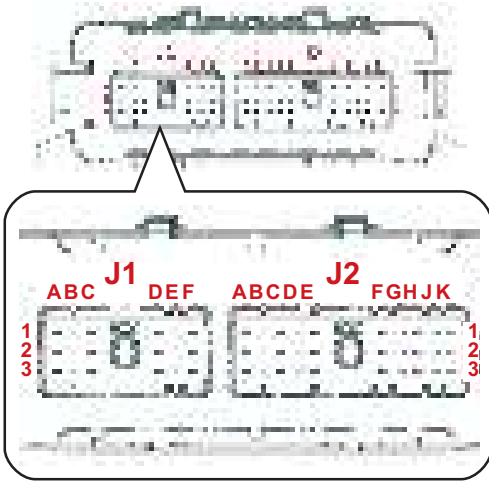
Check point	Check item (method)	Remarks
8. Glow plug	<p>1. Glow plug ring terminal</p> <ul style="list-style-type: none"> - The resistance between the terminal and ground (chassis) is approx. 0.43 Ω 1. If the measured resistance is "∞": open circuit 2. If the measured resistance is "0": short circuit <p>2. Check the voltage when in operation</p> <ul style="list-style-type: none"> - With the plug automatically preheated, the voltage between the glow plug and ground should be 12 V. (Voltage fluctuation by operating time: 8~12V) 	 <p style="text-align: right;">UUVWA72A</p>
9. ECU K9 2400 SW(GW)	<p>1. ECU glow relay (J1-D2) and glow lamp (J1-E1) terminal inspection.</p> <ul style="list-style-type: none"> - Check if the voltage at the each terminal is 12V with the key switch in "ON" position 	 <p style="text-align: right;">B20WBB2A</p>

7.2.6 WHEN HIGH AND LOW BEAMS CANNOT BE OPERATED

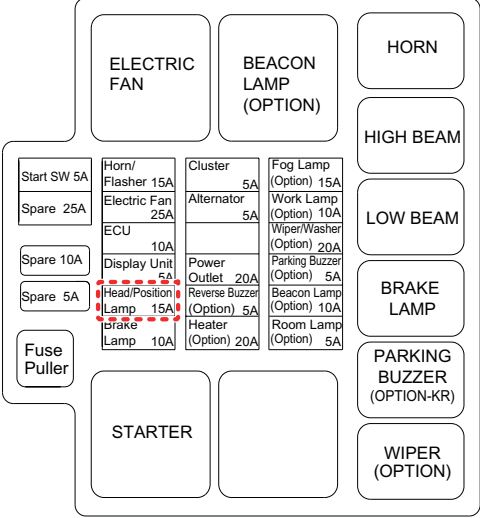
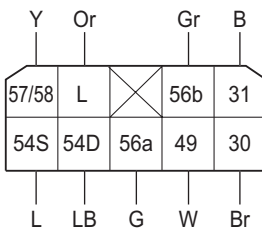
Check point	Check item (method)	Remarks
1. Fuse	<p>K9 2400D - AU, K9 2400 -EU</p> <ul style="list-style-type: none"> - Check fuse engagement. - Fuse for open circuit <ul style="list-style-type: none"> ● Fuse 15 : Head/Position lamp (15A) 	 <p>M24WC66A</p>
	<p>K9 2400 SW(GW)</p> <ul style="list-style-type: none"> - Check fuse engagement. - Fuse for open circuit <ul style="list-style-type: none"> ● Fuse 16 : Head/Position lamp (15A) 	 <p>K24WC40A</p>
2. Combination switch	<ul style="list-style-type: none"> - Check the low beam for proper connection. 30-57/58-56b: connected - Check the high beam for proper connection. 30-57/58-56a: connected - Turn signal lamp (LH), L-54D: connected - Turn signal lamp (RH), L-54S: connected 	 <p>M24WC67A</p>

SAFETY FIRST
GENERAL
ENGINE
CVT
TRANSMISSION
CHASSIS
REAR AXLE
BRAKE
FRONT AXLE
STEERING
HYDRAULIC
ELECTRIC
INDEX

7.2.7 SPEEDOMETER OPERATION WITH THE ENGINE RUNNING

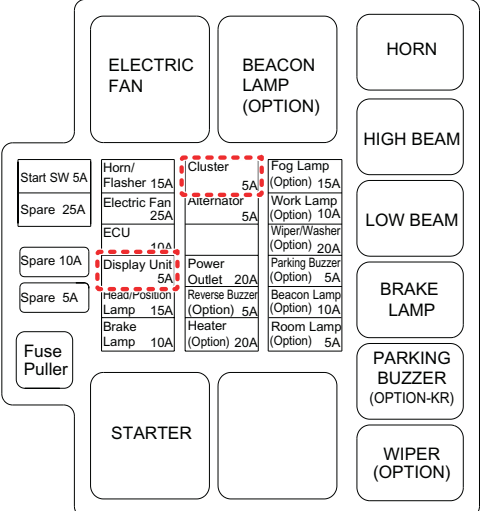
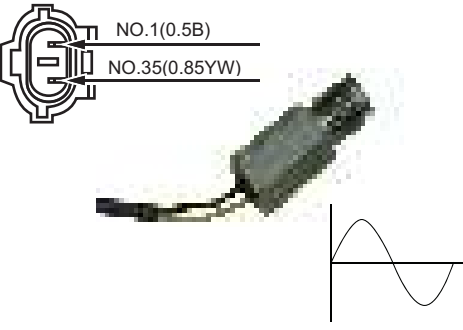
Check point	Check item (method)	Remarks
1. Fuse	<p>K9 2400D - AU, K9 2400 -EU</p> <ul style="list-style-type: none"> - Check fuse engagement. - Fuse 6 for open circuit - Fuse 14 for open circuit <ul style="list-style-type: none"> ● Fuse 6 : Cluster (5A) ● Fuse 14 : Display unit (5A) 	 <p style="text-align: right;">M24WC41A</p>
2. Speed sensor	<p>K9 2400 SW(GW)</p> <ul style="list-style-type: none"> - Check fuse engagement. - Fuse 7 for open circuit - Fuse 15 for open circuit <ul style="list-style-type: none"> ● Fuse 7 : Cluster (5A) ● Fuse 15 : Display unit (5A) 	 <p style="text-align: right;">K24WC41A</p>
	<ul style="list-style-type: none"> - Check the output of sine wave between the NO. 35 and 1 terminals using a voltmeter or oscilloscope for frequency reading. 	 <p style="text-align: right;">UUVWA68A</p>

- SAFETY FIRST
- GENERAL
- ENGINE
- CVT
- TRANSMISSION
- CHASSIS
- REAR AXLE
- BRAKE
- FRONT AXLE
- STEERING
- HYDRAULIC
- ELECTRIC**
- INDEX

Check point	Check item (method)	Remarks																														
3. Display unit	<p>US</p> <ul style="list-style-type: none"> - Check if the voltage between No. 6 and 9 terminals is 12 V. <p>EU</p> <ul style="list-style-type: none"> - Check if the voltage between No. 6 and 14 terminals is 12 V. <p>AU</p> <ul style="list-style-type: none"> - Check if the voltage between No. 6 and 9 terminals is 12 V. 	<table border="1"> <thead> <tr> <th>No.</th> <th>Signal</th> </tr> </thead> <tbody> <tr> <td rowspan="2">US</td> <td>6</td> <td>GND</td> </tr> <tr> <td>9</td> <td>Pick up sensor</td> </tr> <tr> <td rowspan="2">EU</td> <td>6</td> <td>Speed sensor input</td> </tr> <tr> <td>14</td> <td>GND</td> </tr> <tr> <td rowspan="2">AU</td> <td>6</td> <td>GND</td> </tr> <tr> <td>9</td> <td>Electronic pickup signal from ground speed</td> </tr> </tbody> </table> <p>US/AU</p> <table border="1"> <tr> <td>6</td><td>5</td><td>4</td><td>3</td><td>2</td><td>1</td> </tr> <tr> <td>13</td><td>12</td><td>11</td><td>10</td><td>9</td><td>8</td><td>7</td> </tr> </table> <p>EU</p> <p>K24WC57A</p>	No.	Signal	US	6	GND	9	Pick up sensor	EU	6	Speed sensor input	14	GND	AU	6	GND	9	Electronic pickup signal from ground speed	6	5	4	3	2	1	13	12	11	10	9	8	7
No.	Signal																															
US	6	GND																														
	9	Pick up sensor																														
EU	6	Speed sensor input																														
	14	GND																														
AU	6	GND																														
	9	Electronic pickup signal from ground speed																														
6	5	4	3	2	1																											
13	12	11	10	9	8	7																										
4. Speedometer on combi-meter	<ul style="list-style-type: none"> - Voltage between the Pin B9 and B1 (GND) terminals: 12.5V 	<p>M24WC48A</p>																														

SAFETY FIRST
 GENERAL
 ENGINE
 CVT
 TRANSMISSION
 CHASSIS
 REAR AXLE
 BRAKE
 FRONT AXLE
 STEERING
 HYDRAULIC
ELECTRIC
 INDEX

SAFETY FIRST

GENERAL

ENGINE

CVT

TRANSMISSION

CHASSIS

REAR AXLE

BRAKE

FRONT AXLE

STEERING

HYDRAULIC

ELECTRIC

INDEX

7.2.8 FUEL GAUGE OPERATION

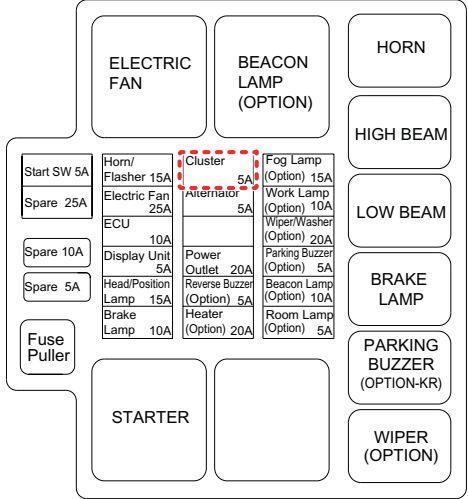
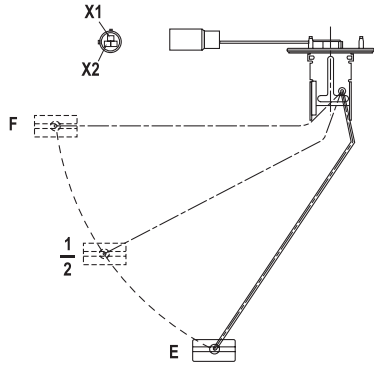
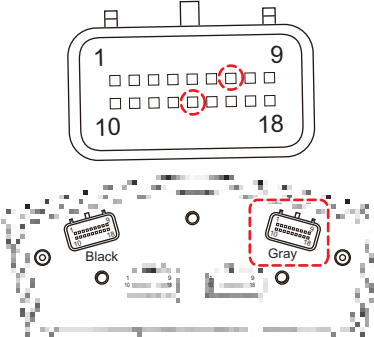
Check point	Check item (method)	Remarks
1. Fuse	<p>K9 2400D - AU, K9 2400 -EU</p> <ul style="list-style-type: none"> - Check fuse engagement. - Fuse 6 for open circuit • Fuse 6 : Cluster (5A) 	 <p>M24WC42A</p>
	<p>K9 2400 SW(GW)</p> <ul style="list-style-type: none"> - Check fuse engagement. - Fuse 7 for open circuit • Fuse 7 : Cluster (5A) 	 <p>K24WC38A</p>
2. Fuel sender	<p>Measure the resistance between two terminals of fuel sender connector after disconnecting wiring and connector.</p> <ul style="list-style-type: none"> - E point: 110 Ω - F point: 2.5 Ω 	 <p>T46WBG5A</p>
3. Fuel gauge on instrument panel	<p>Measure the resistance between the Pin G14 and G7 terminals of instrument panel connector, referring to resistance value specified for each fuel sender position.</p>	<p>Instrument panel connector</p>  <p>UUVWA70A</p>

8. COMPONENTS AND JOB CODES

8.1 G633001 GROUP FOR DISPLAY CONTROL

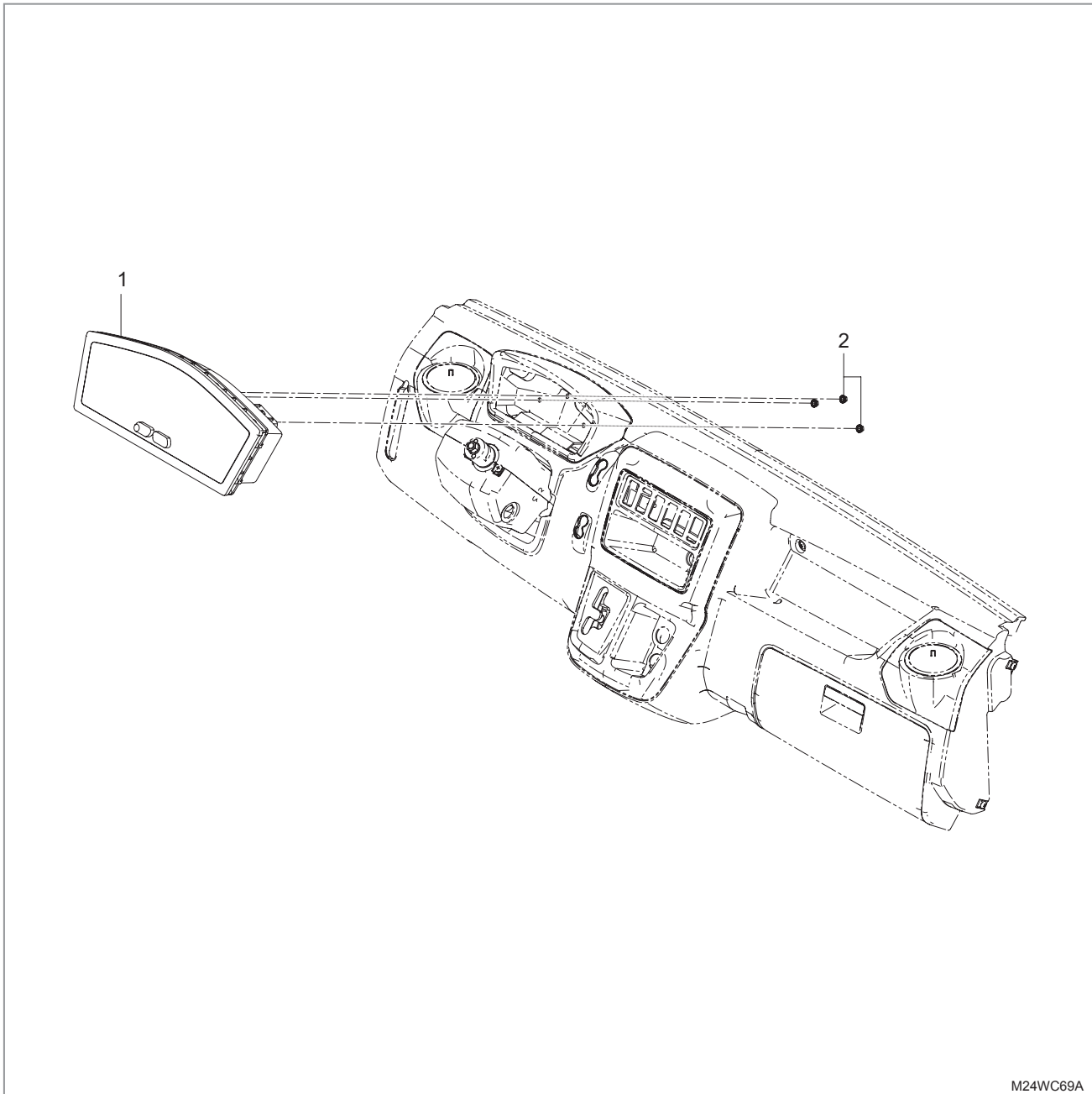

COMPONENTS AND JOB CODES

(1) Assy Panel, Instrument (V110001)

(2) Flange Nut

SAFETY FIRST

GENERAL

ENGINE

CVT

TRANSMISSION

CHASSIS

REAR AXLE

BRAKE

FRONT AXLE

STEERING

HYDRAULIC

ELECTRIC

INDEX

SAFETY FIRST

GENERAL

ENGINE

CVT

TRANSMISSION

CHASSIS

REAR AXLE

BRAKE

FRONT AXLE

STEERING

HYDRAULIC

ELECTRIC

INDEX

8.2 G611001 ENGINE ELECTRICAL COMPONENTS AND JOB CODES GROUP (1)

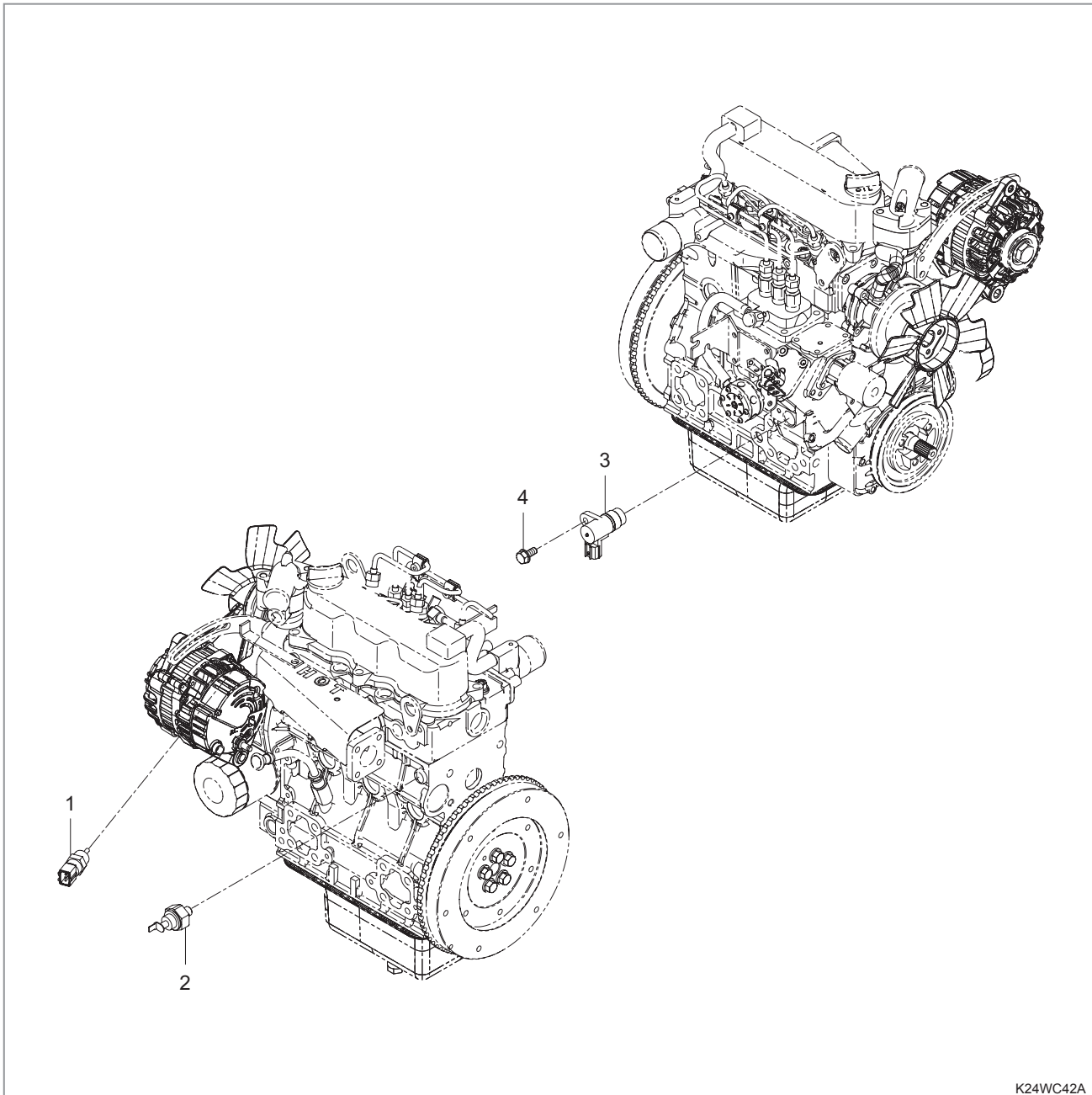

K24WC42A

COMPONENTS AND JOB CODES

- (1) Temperature Sensor Assy (V010001)
- (2) Oil Switch (V010002)

- (3) Sensor, Electron Pick Up (V010003)
- (4) Bolt, Flange

8.3 G632001 POWER SOCKET GROUP

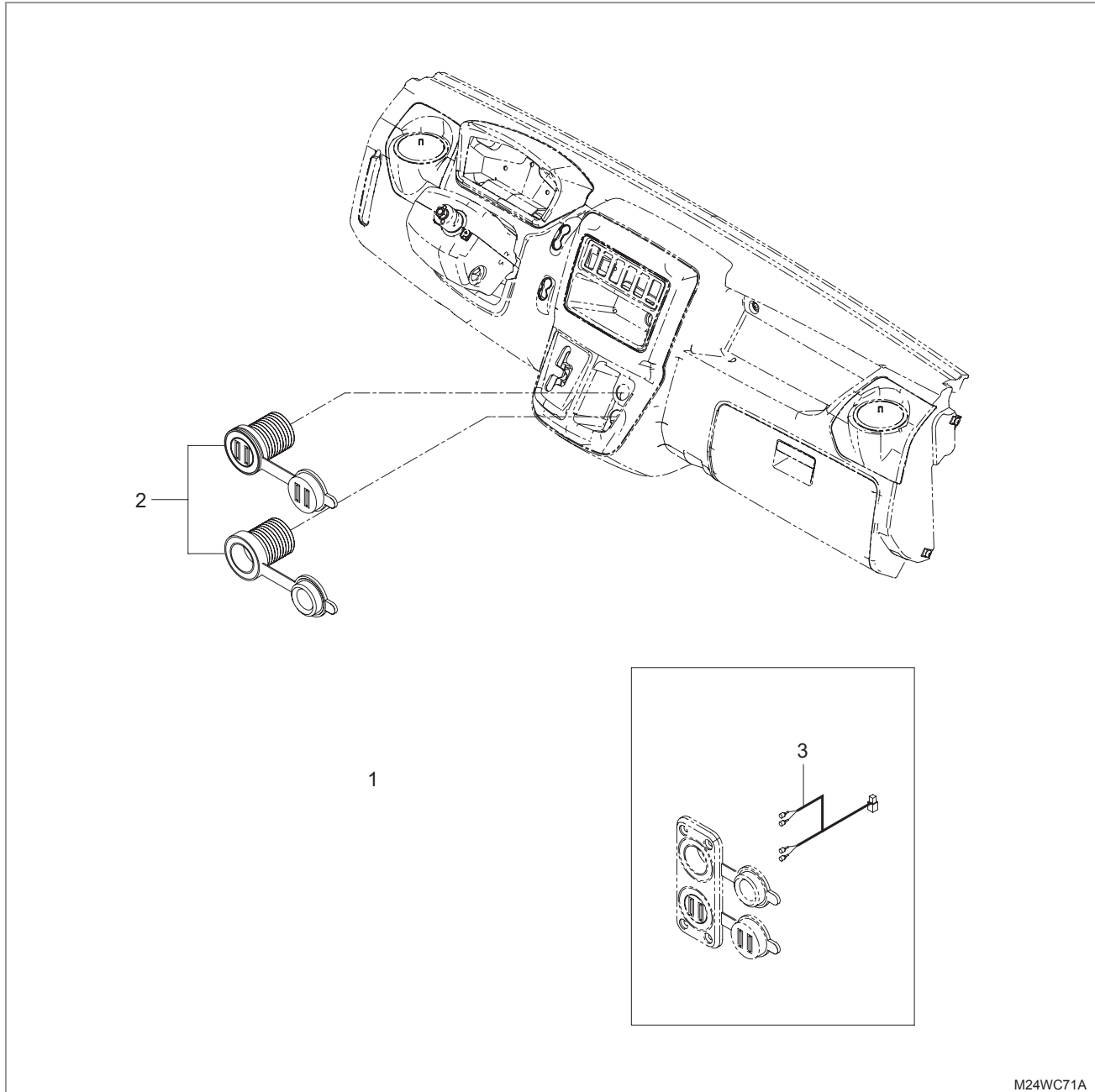

M24WC71A

COMPONENTS AND JOB CODES

(1) Soket (V100001)

(2) Socket-USB-power (V100002)

(3) Wire Harness Assy, Connecting-USB-power (V100003)

SAFETY FIRST

GENERAL

ENGINE

CVT

TRANSMISSION

CHASSIS

REAR AXLE

BRAKE

FRONT AXLE

STEERING

HYDRAULIC

ELECTRIC

INDEX

SAFETY FIRST

GENERAL

ENGINE

CVT

TRANSMISSION

CHASSIS

REAR AXLE

BRAKE

FRONT AXLE

STEERING

HYDRAULIC

ELECTRIC

INDEX

8.4 G631004 WIRE HARNESS GROUP

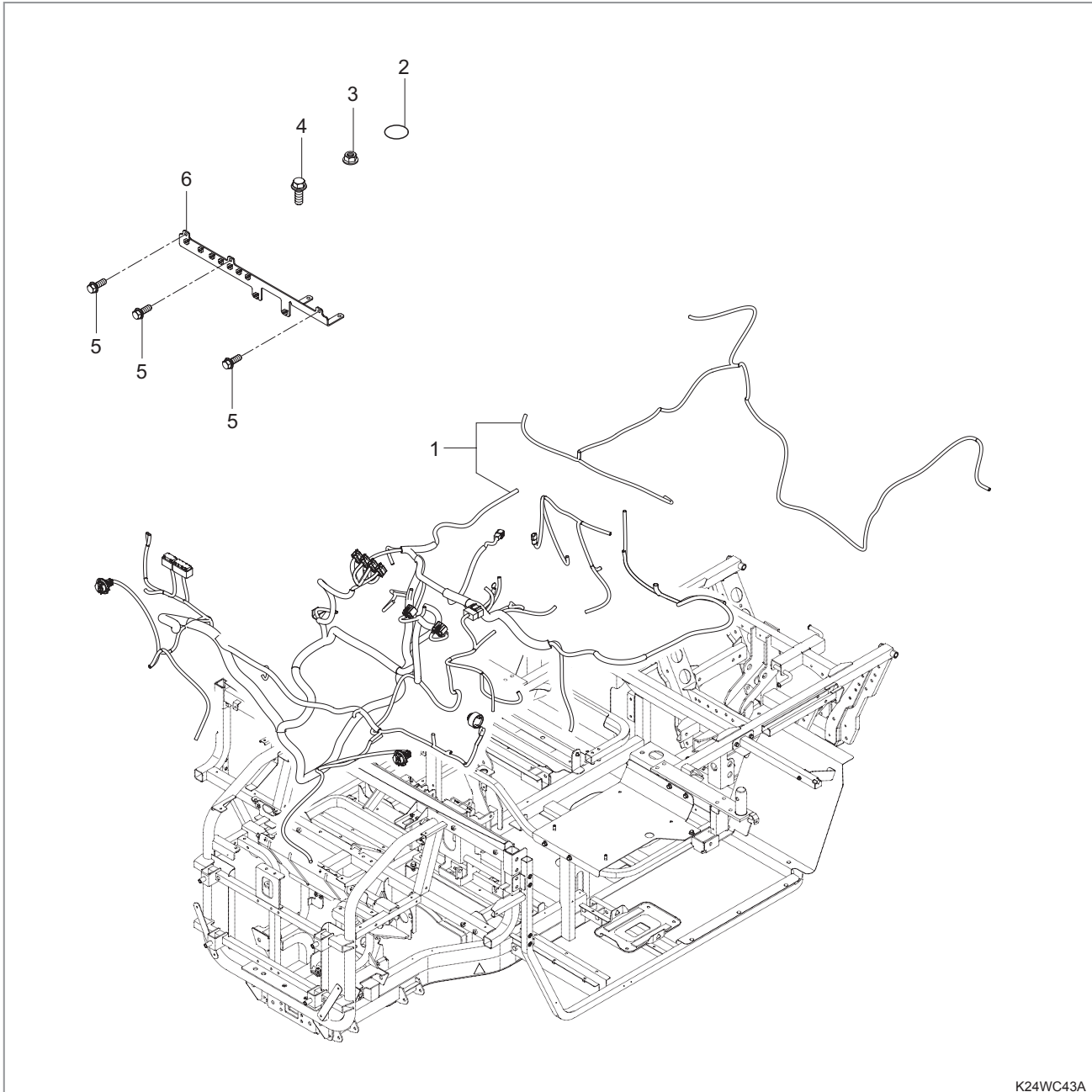

K24WC43A

COMPONENTS AND JOB CODES

- | | |
|---|----------------------------------|
| (1) Assy Wire Harness, Main-(CVT,US,2S) (V090001) | (4) Bolt, Flange |
| (2) Plug | (5) Bolt, Flange |
| (3) Flange Nut | (6) Relay Bracket Assy (V090002) |

8.5 G633501 FUEL SENDER GROUP

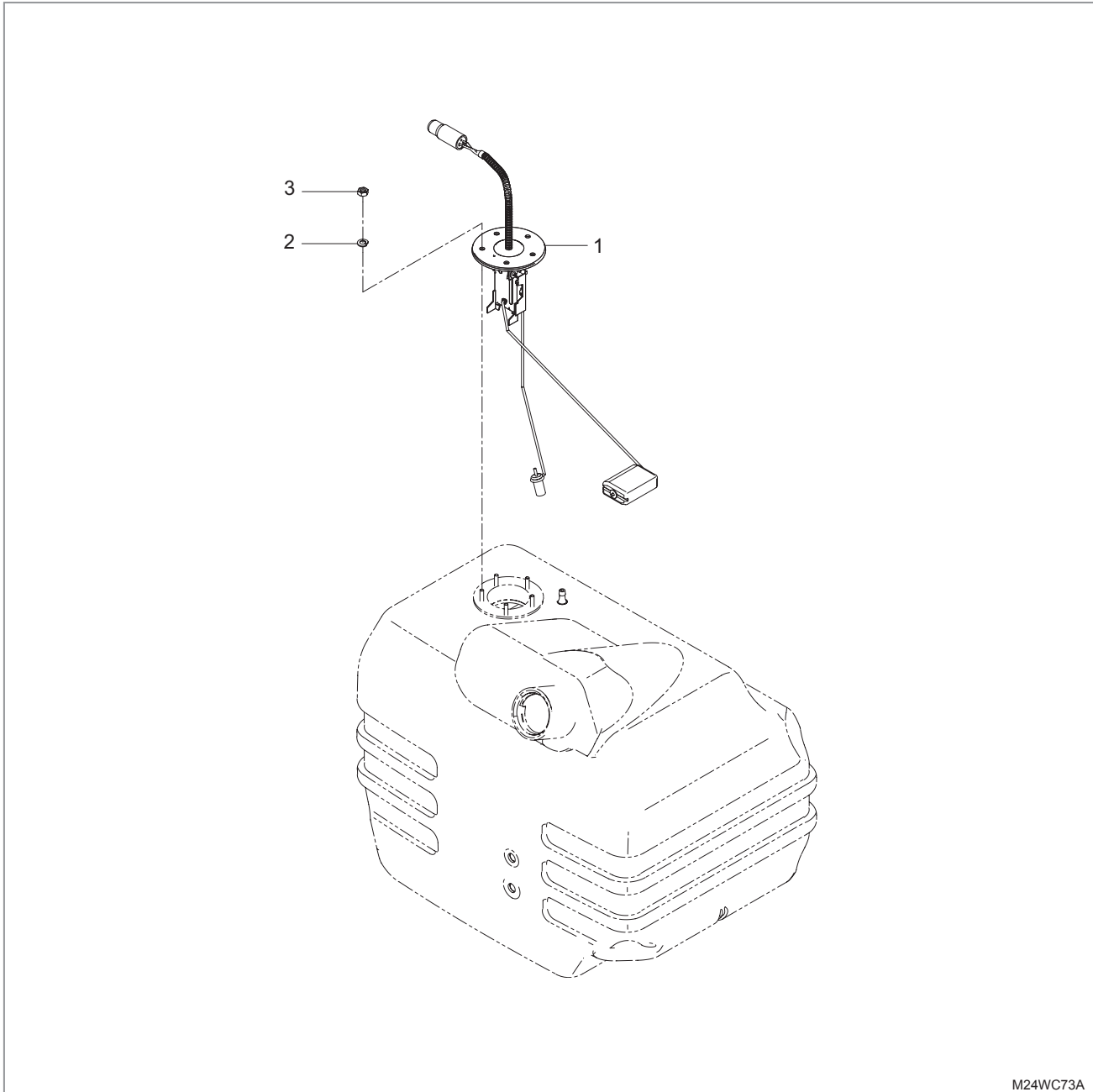

COMPONENTS AND JOB CODES

(1) Unit, fuel (V120001)

(2) Washer, Spring

(3) Nut

SAFETY FIRST
GENERAL
ENGINE
CVT
TRANSMISSION
CHASSIS
REAR AXLE
BRAKE
FRONT AXLE
STEERING
HYDRAULIC
ELECTRIC
INDEX

SAFETY FIRST

GENERAL

ENGINE

CVT

TRANSMISSION

CHASSIS

REAR AXLE

BRAKE

FRONT AXLE

STEERING

HYDRAULIC

ELECTRIC

INDEX

8.6 G622502 TAIL LAMP GROUP

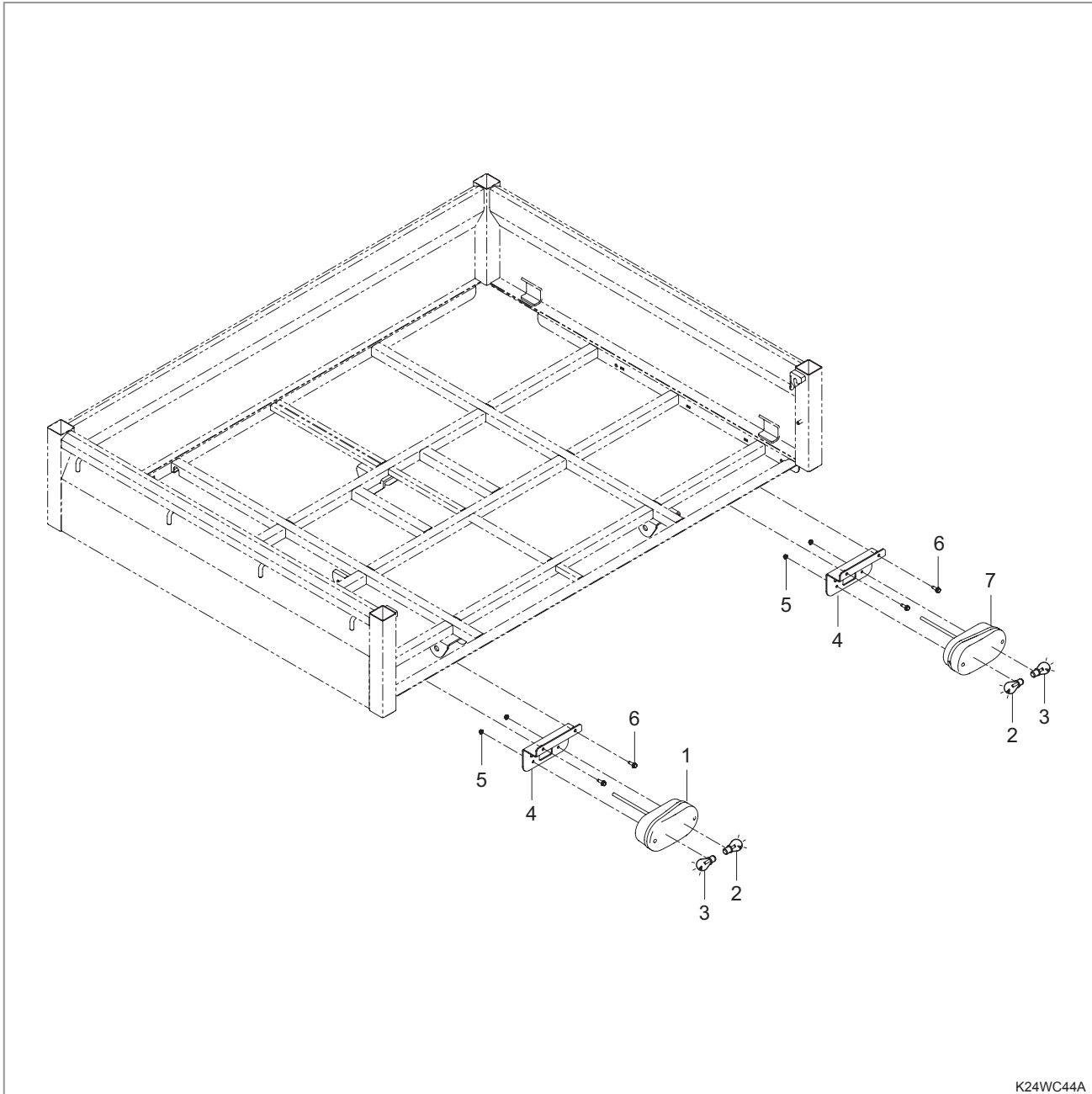

COMPONENTS AND JOB CODES

- | | |
|--|--------------------------------|
| (1) Rear Light Assembly-sae_LH (V070001) | (5) Flange Nut |
| (2) Bulb, 12V X 21W (V070002) | (6) Bolt, flange |
| (3) Bulb, 12V X P21 X 5W (V070003) | (7) Rear Light Assembly-sae_RH |
| (4) Rr Combi Lamp Bracket Assy (V070004) | |

8.7 G615503 SAFETY STARTER GROUP

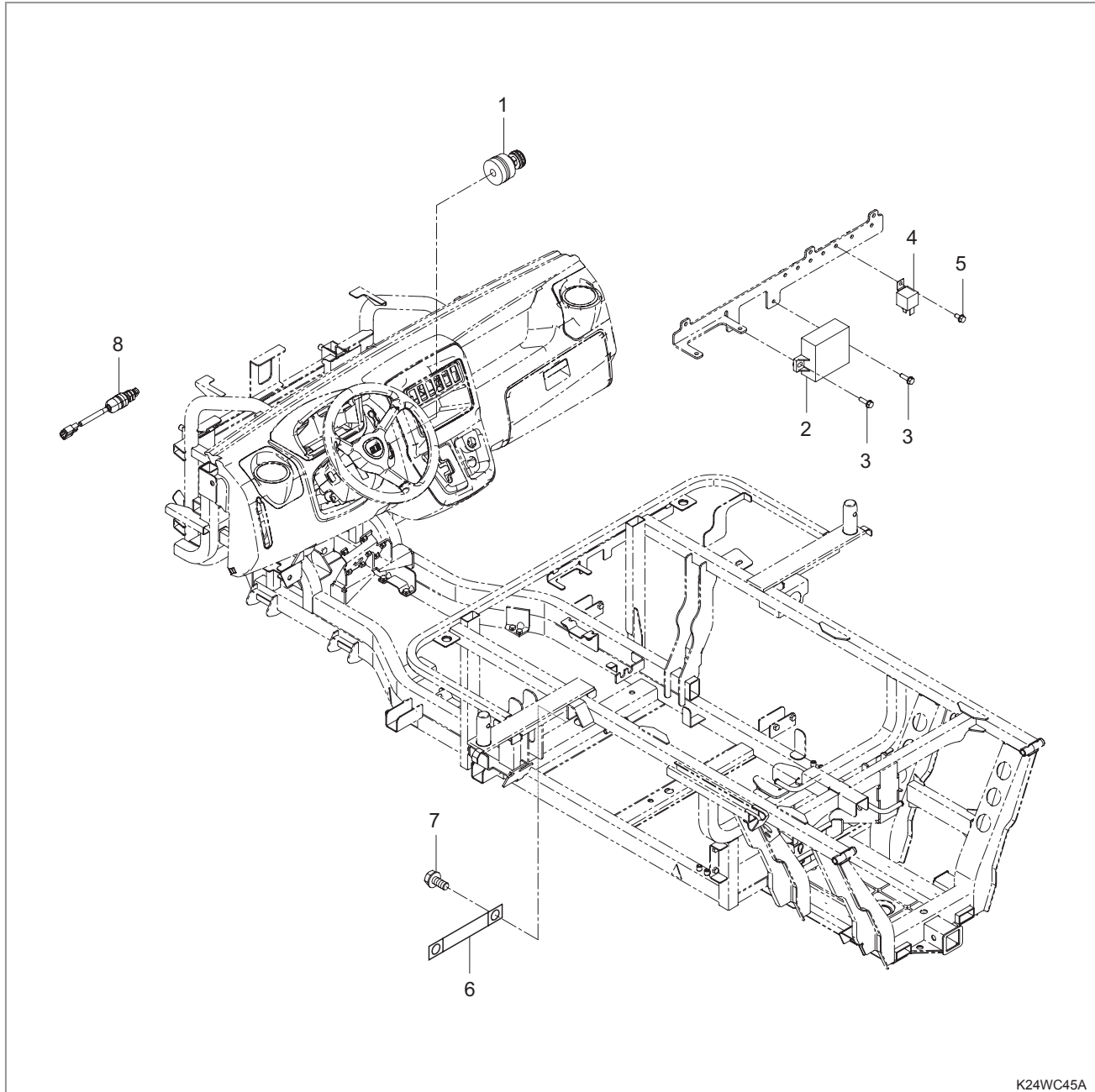

K24WC45A

COMPONENTS AND JOB CODES

- | | |
|---------------------------------------|--------------------------------|
| (1) Assy Switch,starter (V050001) | (5) Bolt, Flange |
| (2) Assy Unit, Display-(US) (V050002) | (6) Cable, Grounding (V050004) |
| (3) Bolt, Flange | (7) Bolt |
| (4) Relay (4P) (V050003) | (8) Assy Switch,stop (V050005) |

SAFETY FIRST

GENERAL

ENGINE

CVT

TRANSMISSION

CHASSIS

REAR AXLE

BRAKE

FRONT AXLE

STEERING

HYDRAULIC

ELECTRIC

INDEX

- SAFETY FIRST
- GENERAL
- ENGINE
- CVT
- TRANSMISSION
- CHASSIS
- REAR AXLE
- BRAKE
- FRONT AXLE
- STEERING
- HYDRAULIC
- ELECTRIC**
- INDEX

8.8 G614501 GLOW CONTROL GROUP

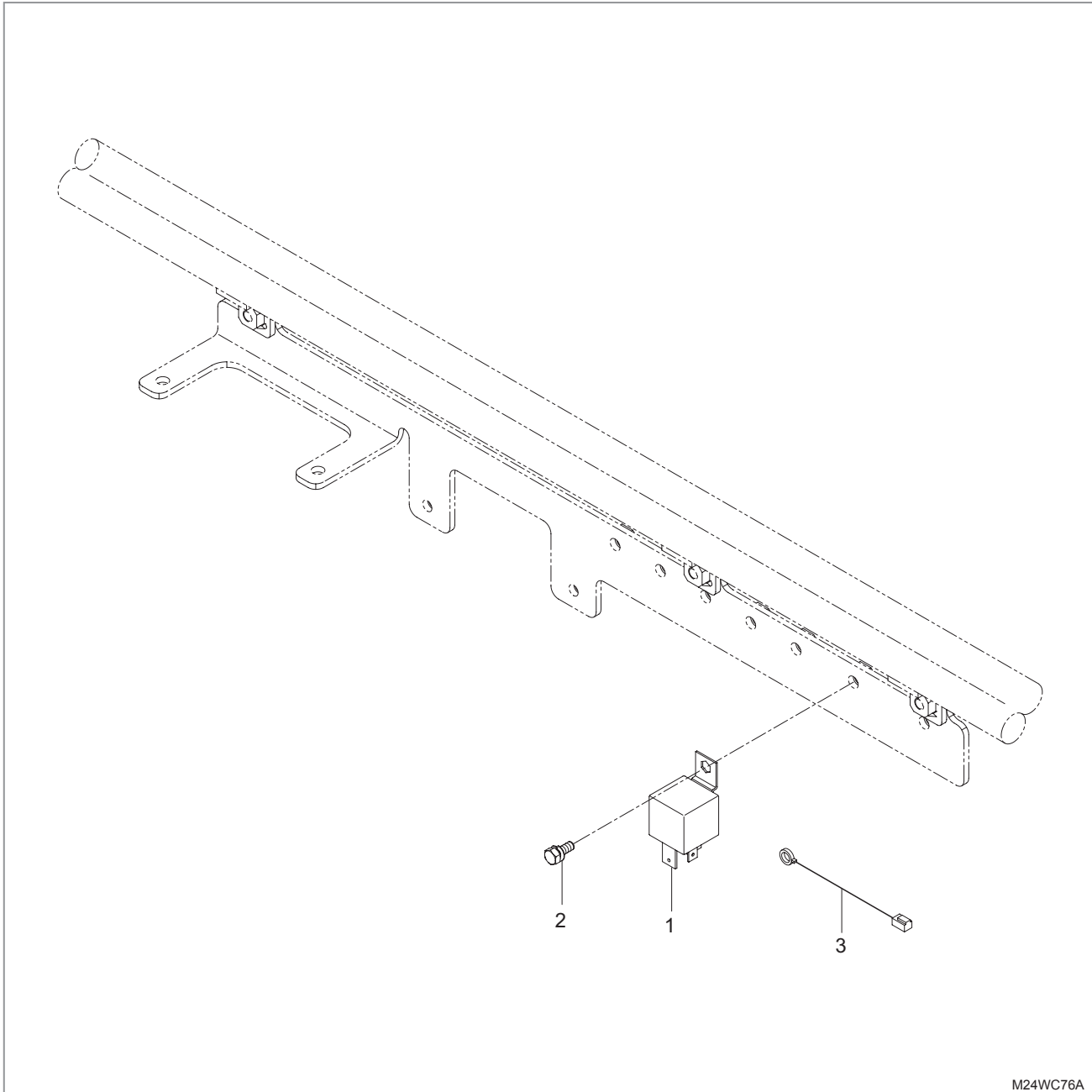

COMPONENTS AND JOB CODES

- (1) Relay (4P) (V040001)
- (2) Bolt, Flange

- (3) Wire Harness 3 (V040002)

8.9 G621001 HEAD LIGHT GROUP

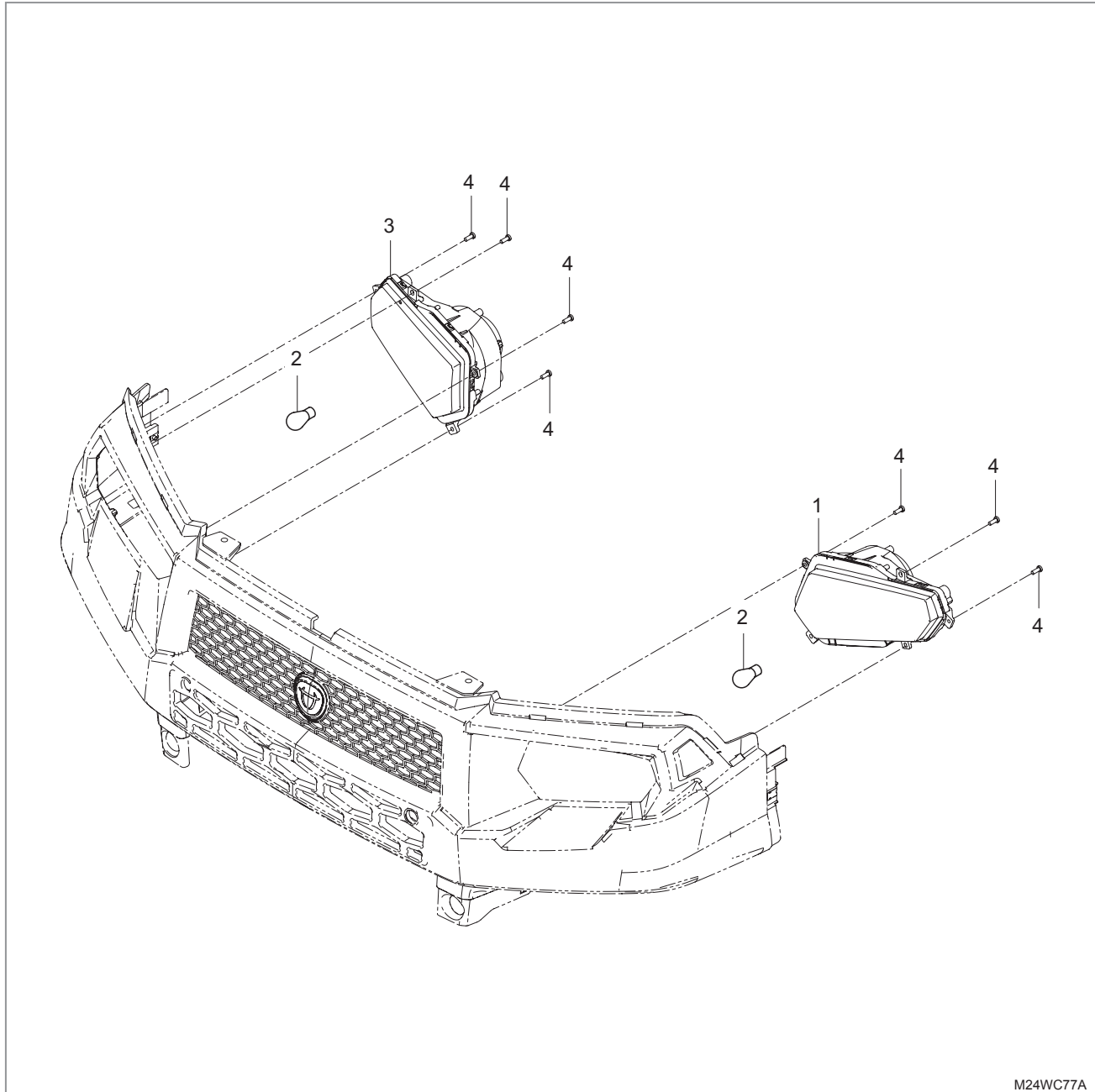

COMPONENTS AND JOB CODES

- (1) Assy Headlight- (LH) (V060001)
- (2) Bulb, Halogen-hs1 12V X 35W X 35W (V060002)
- (3) Assy Headlight- (RH) (V060003)
- (4) Screw

SAFETY FIRST
GENERAL
ENGINE
CVT
TRANSMISSION
CHASSIS
REAR AXLE
BRAKE
FRONT AXLE
STEERING
HYDRAULIC
ELECTRIC
INDEX

MEMO

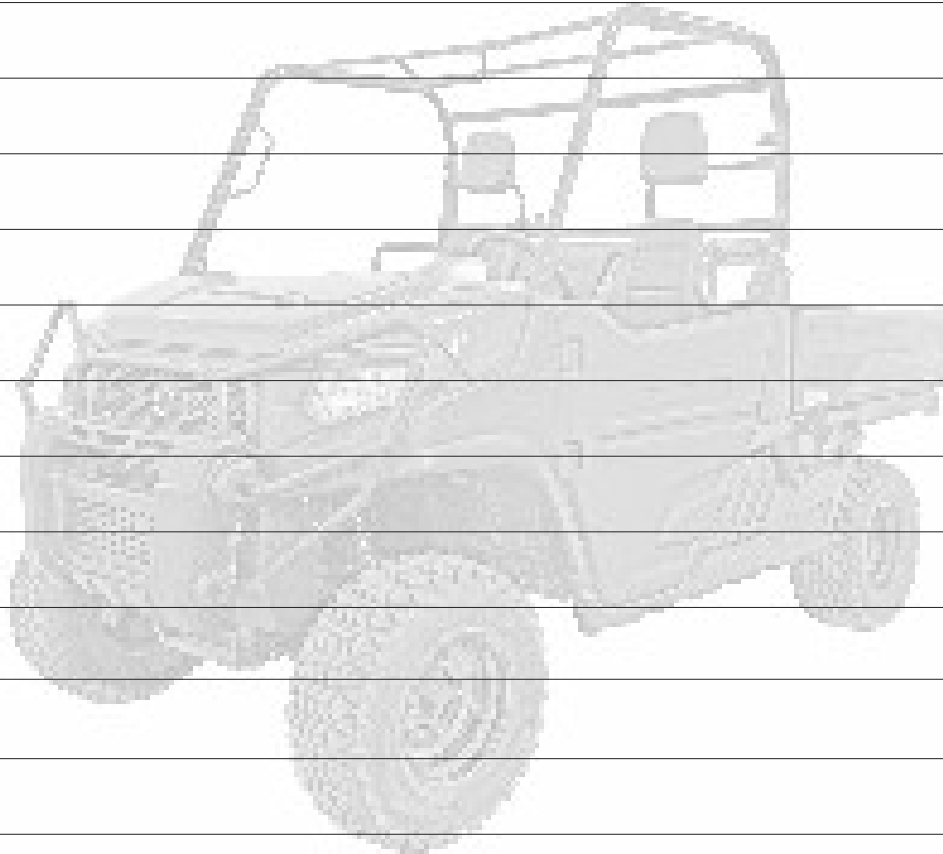



**K9 2400
K9 2440**

INDEX

CHAPTER 13

SAFETY FIRST	A		Camshaft 3-13	
	GENERAL	Accelerator pedal cable adjustment 3-52	Camshaft and fuel camshaft 3-19	
		Actuator [K9 2400 SW(GW)] 12-64	Cargo bed / Implement cable adjustment (if equipped) 6-4	
		Adjusting distance between shafts for pulleys.... 4-9	Cargo bed removal..... 6-5	
		Air cleaner 3-36	Cautions for high pressure hoses..... 1-5	
		Air cleaner 3-41	Cautions when handling the battery 1-5	
		Alert symbols 1-2	Cautions when handling tires 1-8	
		ENGINE	Alternator 12-43	Check and replacement for CVT belt 4-10
			American standard screws, bolts and nuts with UNC or UNF threads..... 2-17	Check the charge warning lamp for malfunction. 12-86
			CVT	Atmospheric pressure sensor [K9 2400 SW(GW)]..... 12-65
Auxiliary hydraulic valve (Optional) 11-16				Circuit diagram 12-4
TRANSMISSION	Auxiliary hydraulic valve disassembly 11-24		Clearance adjustment..... 3-56	
	Auxiliary hydraulic valve, dumping valve and front block (relief valve) disassembly and assembly (Optional) 11-22		Clearance between piston pin and bushing..... 3-61	
CHASSIS	Axle drive shaft disassembly and assembly 5-18		Color code of wire..... 12-4	
	B			
REAR AXLE	Backlash of 10 spiral bevel pinion shaft and 31 bevel gear..... 5-9		Combination switch 12-48	
	Backlash of 8 bevel pinion shaft and 34 bevel gear..... 9-10		Connecting rods 3-18	
	Backlash of differential pinion and differential side gear 9-9	Control valve assembly 11-14		
BRAKE	Basic principle of governor system..... 3-34	Coolant temperature sensor..... 12-39		
	Basic principle of governor system..... 3-39	Cooling fan motor 12-30		
FRONT AXLE	Battery 12-77	Cooling system 3-25		
	Bleeding brake line 8-13	Crankshaft 3-14		
	Bleeding the fuel system 3-28	Crankshaft 3-18		
STEERING	Body and power train..... 3-17	Crankshaft check..... 3-62		
	Bolts..... 2-18	Crankshaft deflection..... 3-62		
	Brake disc runout..... 8-6	Cross section of wire 12-4		
HYDRAULIC	Brake disc thickness..... 8-6	CV joint boot replacement 7-25		
	Brake lamp switch 12-61	CV joint boot replacement 9-15		
	Brake lamp switch installation clearance 8-7	CV joint removal 9-13		
ELECTRIC	Brake master cylinder disassembly 8-12	CVT assembly 4-13		
	Brake pedal free play..... 8-8	CVT disassembly..... 4-11		
	Bubble test for radiator 3-56	Cylinder block 3-17		
INDEX	Bulb replacement..... 12-32	Cylinder bore check..... 3-60		
	C			
	Cable adjustment..... 5-12	Cylinder head 3-12		
Caliper pad clearance and thickness 8-7	Cylinder head 3-17			
		Cylinder head 3-78		
		Cylinder head check 3-59		
		Cylinder head surface flatness 3-59		
		Cylinder head valve recess 3-59		
		D		
		Description for symbols and abbreviations..... 2-2		

Diagnosis and troubleshooting	12-77	Electrical components	12-26
Differential case, spiral bevel gear and differential side gear	9-13	Engine component disassembly and assembly ...	3-78
Differential lock cable adjustment	7-15	Engine component disassembly and assembly ...	3-90
Differential pinion and differential pinion shaft..	9-12	Engine dimensions	3-5
Differential system assembly	7-9	Engine dimensions	3-9
Differential system assembly	9-20	Engine identification	3-4
Differential system clearance check	9-12	Engine identification	3-8
Differential system disassembly	9-19	Engine oil flow	3-23
Differential system disassembly and assembly ...	9-19	Engine oil pressure.....	3-55
Dimensions	2-5	Engine oil pressure switch.....	12-39
Disassembled view.....	3-33	Engine oil relief valve.....	3-96
Disassembled view.....	3-38	Engine performance curve	3-6
Disassembly, service and assembly.....	3-70	Engine performance curve	3-10
Disassembly, service and assembly.....	4-11	Engine removal.....	3-70
Disassembly, service and assembly.....	5-14	Engine serial number location	2-4
Disassembly, service and assembly.....	6-5	Engine stop solenoid	12-36
Disassembly, service and assembly.....	8-9	Engine views	3-4
Disassembly, service and assembly.....	9-13	Engine views	3-8
Disassembly, service and assembly.....	10-9	Exploded view	3-97
Disassembly, service and assembly.....	11-20	E010 Cylinder block group	3-97
Disassembly, service and assembly	7-16	E030 Cylinder head group	3-98
Display unit.....	12-26	E040 Gear case group	3-99
Disposal of environmental waste.....	1-8	E050 Main bearing case group	3-101
Drive pulley assembly components disassembly and assembly	4-14	E080 Valve rocker arm group	3-102
Driven pulley assembly components disassembly and assembly	4-18	E100 Camshaft group	3-103
Driving speed.....	2-11	E110 Piston & crankshaft group	3-104
Dumping cylinder (AU:STD, US/EU:OPT).....	11-12	E130 Nozzle holder group	3-105
Dumping cylinder disassembly	11-30	E140 Fuel camshaft group	3-106
Dumping cylinder disassembly and assembly (AU:STD, US/EU:OPT.).....	11-29	E150 Speed control lever group	3-107
Dumping cylinder removal.....	11-29	E160 Engine stop lever group	3-108
Dumping operation	11-6	E200 Dynamo group	3-110
Dumping valve disassembly (AU:STD, US/EU:OPT.).....	11-27	Exploded view	4-19
E			
ECU	12-23	G440001 CVT cover group	4-19
ECU & Sensors (for 3C100 LFU-U2).....	3-42	G140004 CVT	4-20
ECU (Eletronic control unit).....	3-42	Exploded view	5-25
ECU [K9 2400 SW(GW)]	12-62	G113002 Range shaft group	5-25
ECU diagnostic connector	12-63	G116002 Front wheel drive shaft group	5-26
		G115002 Rear wheel driving shaft group ..	5-27
		G117002 Shift fork group	5-28
		G118002 Front drive fork group	5-29
		G151003 Rear propeller shaft group	5-30

SAFETY FIRST
GENERAL
ENGINE
CVT
TRANSMISSION
CHASSIS
REAR AXLE
BRAKE
FRONT AXLE
STEERING
HYDRAULIC
ELECTRIC
INDEX

SAFETY FIRST
GENERAL
ENGINE
CVT
TRANSMISSION
CHASSIS
REAR AXLE
BRAKE
FRONT AXLE
STEERING
HYDRAULIC
ELECTRIC
INDEX

G114002 Sprial bevel gear group 5-31

G150002 Front propeller shaft group 5-32

G112002 Input shaft group 5-33

G111002 Transmission case group 5-34

Exploded view 6-10

G850002 ROPS group (CREW) 6-10

G300002 Accelerator pedal group (CVT) .. 6-11

G820002 Guard group (Extendable) 6-12

G400001 Engine mounting group (CVT) ... 6-13

G860007 Deck group 6-14

G840004 Exterior molding group (CREW) 6-15

G210004 Lever group (CREW) 6-16

G795301 Hand throttle group (Option) 6-17

G750005 Main frame group (CREW)..... 6-18

Exploded view 7-32

G270001 Rear suspension group 7-32

G120002 Rear axle case group 7-33

G121002 Rear differential group 7-34

G161003 2WD CV joint group 7-35

G122002 Rear differential fork group 7-36

Exploded view 8-17

G340002 Rear brake group (CREW) 8-17

G320001 Front brake group 8-18

G310001 Brake pedal group 8-19

G360005 Parking brake group (US, CREW) . 8-20

Exploded view 9-25

G250001 Front suspension group (CVT) .. 9-25

G130001 Front axle case group 9-26

G132001 Bevel pinion shaft group 9-27

G160001 4WD CV joint group 9-28

G131001 Front diff system group 9-29

Exploded view 10-16

G220002 Steering group (USA) 10-16

G531002 Power steering unit group 10-17

Exploded view 11-31

G513002 Gear pump group 11-31

G551004 Control valve group 11-32

G591002 Dump cylinder group 11-33

G511002 Oil tank group 11-34

Exploded view 12-95

G633001 Group for display control 12-95

G611001 Engine electrical components group (1)..... 12-96

G632001 Power socket group 12-97

G631004 Wire harness group 12-98

G633501 Fuel sender group 12-99

G622502 Tail lamp group 12-100

G615503 Safety starter group 12-101

G614501 Glow control group 12-102

G621001 Head light group 12-103

External hydraulic oil operation (Optional)..... 11-8

External hydraulic pressure 11-20

External wiring diagram for display unit..... 12-27

F

Fan belt..... 3-15

Fan belt tension adjustment 3-52

Fan motor operation 12-21

Fire 1-4

Flasher unit [K9 2400SW(GW) only] 12-51

Flow of fuel 3-28

Flow of intake air and exhaust gas 3-36

Flow of intake air and exhaust gas 3-41

Flywheel 3-20

Flywheel deflection andcrankshaft end play check 3-68

Front and rear wheel brakes..... 8-3

Front axle case disassembly and assembly 9-18

Front axle case removal 9-17

Front axle knuckle assembly disassembly and assembly 9-22

Front axle power transfer diagram..... 9-4

Front block (relief valve) disassembly 11-28

Front wheel brake removal (brake pad and disc replacement)..... 8-11

Front wheel drive system disassembly and assembly 5-24

Fuel camshaft (gear case)..... 3-82

Fuel feed pump..... 3-29

Fuel filter and bleeding 3-28

Fuel gauge operation..... 12-94

Fuel injection nozzles 3-14

Fuel injection pump 3-29

Fuel injection pump 3-80

Fuel sender..... 12-42

SAFETY FIRST	Muffler.....	3-36	Piston rings.....	3-13
	Muffler.....	3-41	Piston, flywheel and crankshaft.....	3-86
GENERAL	N		Pistons.....	3-14
	Neutral switch.....	12-38	Power outlet.....	12-56
ENGINE	Nuts.....	2-19	Power relay / glow relay.....	12-52
	O		Preheating and post heating.....	12-16
CVT	Oil clearance between crank pin and connecting rod big end bearing.....	3-64	Principle of cooling system for CVT.....	4-7
	Oil clearance between crankshaft journal and bearing 1.....	3-63	Propeller shaft (front universal joint) replacement.....	9-24
TRANSMISSION	Oil clearance between crankshaft journal and bearing 2.....	3-63	R	
	Oil pressure switch.....	3-24	Radiator.....	3-15
CHASSIS	Oil pump.....	3-15	Radiator.....	3-27
	Oil pump.....	3-25	Radiator cap.....	3-27
REAR AXLE	Oil pump check.....	3-69	Rear axle case disassembly and assembly.....	7-18
	Operating principle.....	4-4	Rear axle case oil.....	7-2
BRAKE	Operating principle.....	11-3	Rear axle case removal (rear axle disassembly).....	7-16
	Operating principle.....	12-13	Rear axle power transfer diagram.....	7-4
FRONT AXLE	Operating principle of differential lock system....	7-7	Rear axle replacement.....	7-24
	Operating principle of differential system.....	7-6	Rear carrier replacement.....	7-29
STEERING	Operating system diagram.....	10-3	Rear combination lamp.....	12-33
	Operation of governor.....	3-35	Rear differential system disassembly and assembly.....	7-22
HYDRAULIC	Operation of governor.....	3-40	Rear propeller shaft replacement.....	7-30
	Others location.....	2-4	Rear wheel brake removal (brake pad and disc replacement).....	8-9
ELECTRIC	Overall circuit diagram.....	12-7	Relay box.....	12-58
	P		Relief valve.....	3-24
INDEX	Panel disassembly.....	6-6	Rocker arm.....	3-90
	Parking brake.....	8-4	Rocker arm assembly.....	3-19
	Parking brake cable adjustment.....	8-8	Rocker arm assembly check.....	3-58
	Parking brake disassembly and assembly (parking brake pad replacement).....	8-15	S	
	Parking brake switch.....	12-37	Safe workplace.....	1-3
	Part number assignment standard for daedong bolts and nuts.....	2-18	Safety decals.....	1-2
	PCV valve.....	3-37	Safety decals.....	1-9
	PCV valve.....	3-42	Safety equipment.....	1-3
	Piston and piston rings.....	3-18	Safety gear.....	1-3
	Piston assembly.....	3-92	Safety instructions when preparing UTV.....	1-4
	Piston check.....	3-60	Safety tips.....	1-3
	Piston pin bore.....	3-60	Scald prevention.....	1-7
	Piston ring clearance.....	3-62	Sealant and adhesive.....	4-2
	Piston ring end gap.....	3-61	Sealant and adhesive.....	5-3

Sealant and adhesive	9-3	Suspension	7-2
Seat and fender removal	6-5	Suspension assembly removal.....	7-28
Sensor setting.....	5-11	Symbols for electric components.....	12-5
Serial number	2-3	T	
Service specifications	3-12	The location of safety decal.....	1-9
Shift system	5-6	Thermostat	3-15
Slow-blow fuse	12-35	Thermostat	3-26
Snap ring assembly	2-20	Thermostat	3-93
Specification	12-3	Tie-rod length adjustment.....	10-8
Specifications	2-7	Tightening torque.....	3-16
Specifications	3-5	Tightening torque.....	4-2
Specifications	3-9	Tightening torque.....	5-2
Specifications	4-2	Tightening torque.....	7-2
Specifications	5-2	Tightening torque.....	8-2
Specifications	6-2	Tightening torque.....	9-3
Specifications	7-2	Tightening torque.....	10-2
Specifications	8-2	Tightening torque for wheel	2-15
Specifications	9-2	Tightening torques.....	2-16
Specifications	10-2	Timing gear.....	3-64
Specifications	11-2	Timing gear backlash	3-65
Specified inflation pressure	2-15	Timing gear setting	3-64
Speed control lever plate and governor spring	3-81	Timing gears.....	3-20
Speed control system.....	5-5	Tire	6-2
Speed sensor	12-44	Tire maintenance.....	2-15
Speedometer operation with the engine running.....	12-92	Toe-in adjustment	9-8
Spring pin installation	2-20	Toe-in adjustment	10-8
Steering gearbox	10-2	Tooth contact of spiral bevel gear.....	5-10
Steering gearbox components.....	10-5	Tooth contact of spiral bevel gear.....	9-11
Steering gearbox removal and disassembly.....	10-9	Transmission removal	5-14
Structure and function	3-17	Transmission structure	5-4
Structure and function	7-3	Troubleshooting.....	3-50
Structure and function	8-3	Troubleshooting.....	4-8
Structure and function	9-4	Troubleshooting.....	5-8
Structure and function	10-3	Troubleshooting.....	7-8
Structure and operating principle.....	4-3	Troubleshooting.....	8-5
Structure and operating principle.....	5-4	Troubleshooting.....	9-7
Structure in steering gearbox	10-4	Troubleshooting.....	10-7
Structure of CVT (Continuously Variable Transmission).....	4-3	Troubleshooting.....	11-18
Structure of rear axle section.....	7-3	Troubleshooting.....	12-83
Stud	2-16	Turning torque of 8 bevel pinion shaft	9-8
		U	

SAFETY FIRST
GENERAL
ENGINE
CVT
TRANSMISSION
CHASSIS
REAR AXLE
BRAKE
FRONT AXLE
STEERING
HYDRAULIC
ELECTRIC
INDEX

SAFETY FIRST	Unit conversion table 2-21
	Use of appropriate tools and equipment..... 1-6
	UTV appearance 2-3
	UTV serial number location 2-3
GENERAL	V
	Valve cam height measurement 3-68
	Valve camshaft 3-84
ENGINE	Valve camshaft deflection check 3-67
	Valve camshaft gear side clearance..... 3-66
	Valve camshaft oil clearance measurement 3-67
CVT	Valve removal 11-22
	Valve rocker arms..... 3-13
	Valve spring inspection (length, tension and squareness)..... 3-57
TRANSMISSION	Valve spring squareness (tilt) 3-58
	Valve springs 3-12
	Valves 3-12
CHASSIS	Ventilating system..... 1-3
	W
	Water pump 3-94
REAR AXLE	Water pump 3-26
	Wheel drive system 5-7
	When high and low beams cannot be operated.. 12-91
BRAKE	When the engine cannot be started..... 12-83
	When the key switch is turned to “on” position... 12-13
	When the key switch is turned to “start” position... 12-19
FRONT AXLE	When the system is not charged 12-85
	When the system is not preheated automatically... 12-88
	When the system is not preheated manually.. 12-87
STEERING	Wiring 12-67
	Wiring 12-78
	Workplace 1-3
HYDRAULIC	
ELECTRIC	
INDEX	