

# Service Parts Manual For EG2020ASZ&EG2040ASZ

## EG2020ASZ 备件手册

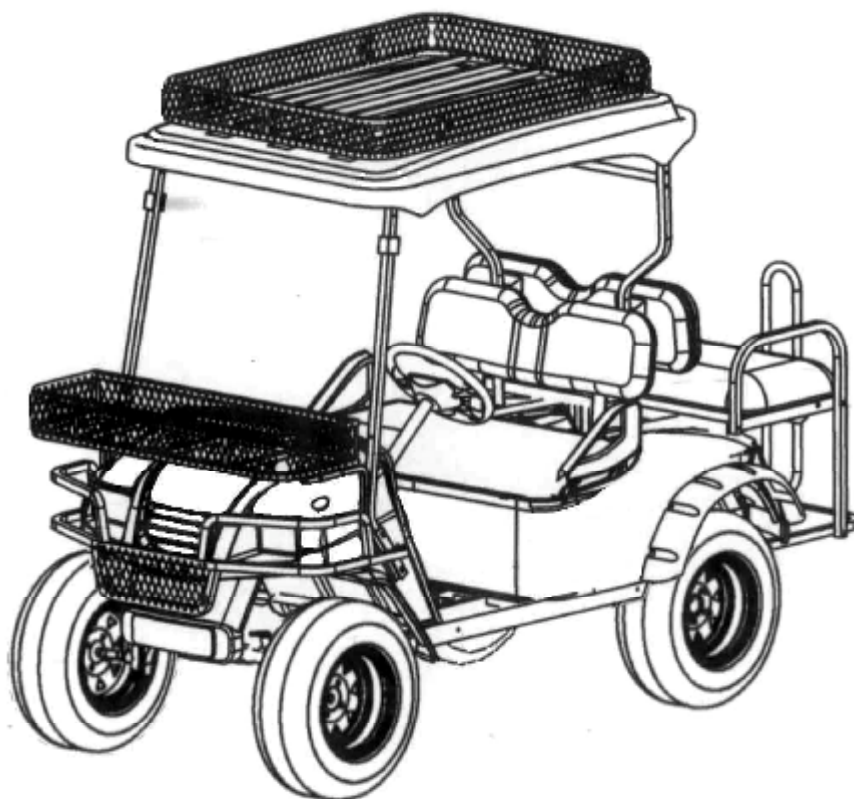

苏州益高电动车辆制造有限公司

SUZHOU EAGLE ELECTRIC VEHICLE MANUFACTURING CO.,LTD

## Index

1-1	Front Cover (前罩)、Instrument Board (仪表盘)	4
1-2	Front windshield (前挡玻璃)	4
	Front Split Windshield (折叠前风挡)	5
	Front One-piece Windshield (非折叠前风挡)	8
1-3	Roof (顶棚)	10
	EG2020ASZ Roof (EG2020ASZ 顶棚)	10
	EG2040ASZ Roof (EG2040ASZ 顶棚)	12
1-4	Top Basket (顶篮)	15
1-5	Front Basket (前篮)	17
1-6	Rear Standing Board, Rear Standing Board Handrail, Flip-flop Seat (后站板、后站板扶手、折叠座椅总成)	19
1-7	Side Rear View Mirror (后视镜)	22
1-8	Wheel Trim (轮眉)	24
1-9	Seat Back, Seat Cushion (靠背, 坐垫)	26
1-10	First row of seat (前排座椅)	29
1-11	Front metallic bumper (前碳钢保险杠)	31
1-12	Front plastic bumper (前塑料保险杠)	32
2-1	Frame, Floor, Side Trim (车架总成、地板、侧护板)	33
3-1	Braking Pedal & Bracket Assembly(制动踏板及支架总成)	35
3-2	Rear Brake Assembly Rear (后轮制动器)	40
4-1	Front Axle Assembly (前桥总成)	42
4-2	Front Hub (前轮毂)	44
5-1	Rear Axle (后桥)	45
5-2	Half Axle Assembly (半轴总成)	47
5-3	Retarder Assembly (主减速器总成)	48
5-4	Differential (差速器)	49
6-1	Front Suspension (前悬架总成)	51
6-2	Rear Suspension (后悬架总成)	53

6-3 Front Shock Absorber (前减震器) .....	55
6-4 Rear Shock Absorber (后减震器) .....	57
7-1 Steering Wheel Assembly (方向盘总成) .....	59
7-2 Tie Rod (横拉杆) .....	61
7-3 Steering Shaft Assembly (转向轴总成) .....	63
7-4 Steering Gear Assembly (转向器总成) .....	65
8-1 Wheel & Tyre (车轮) .....	67
9-1 Motor (电机) .....	68
9-2 Electronic Controller Assembly (电控总成) .....	70
9-4 Batteries & Connect Wire (电池及连线) .....	73
10-1 Instrument Panel, Start Key (仪表盘、启动开关) .....	75
10-2 Combination switch, Loud speaker, Backup buzzer, Electronic flasher, Auxiliary relay, Fuse Box (组合开关、喇叭、倒车蜂鸣器、电子闪光器、辅助继电器、保险盒) .....	77
10-3 Charger (充电器) .....	80
10-4 Light System (灯光系统) .....	81
11-1 Accelerator Assembly (加速器总成) .....	82
11-2 Accelerator Pedal Assembly (加速踏板总成) .....	84
10-3 48V/12V DC Converter (DC 转换器) .....	85

## Option

### A-1. 4-wheel hydraulic drum brake system

## 1-1 Front Cover (前罩)、Instrument Board (仪表盘)

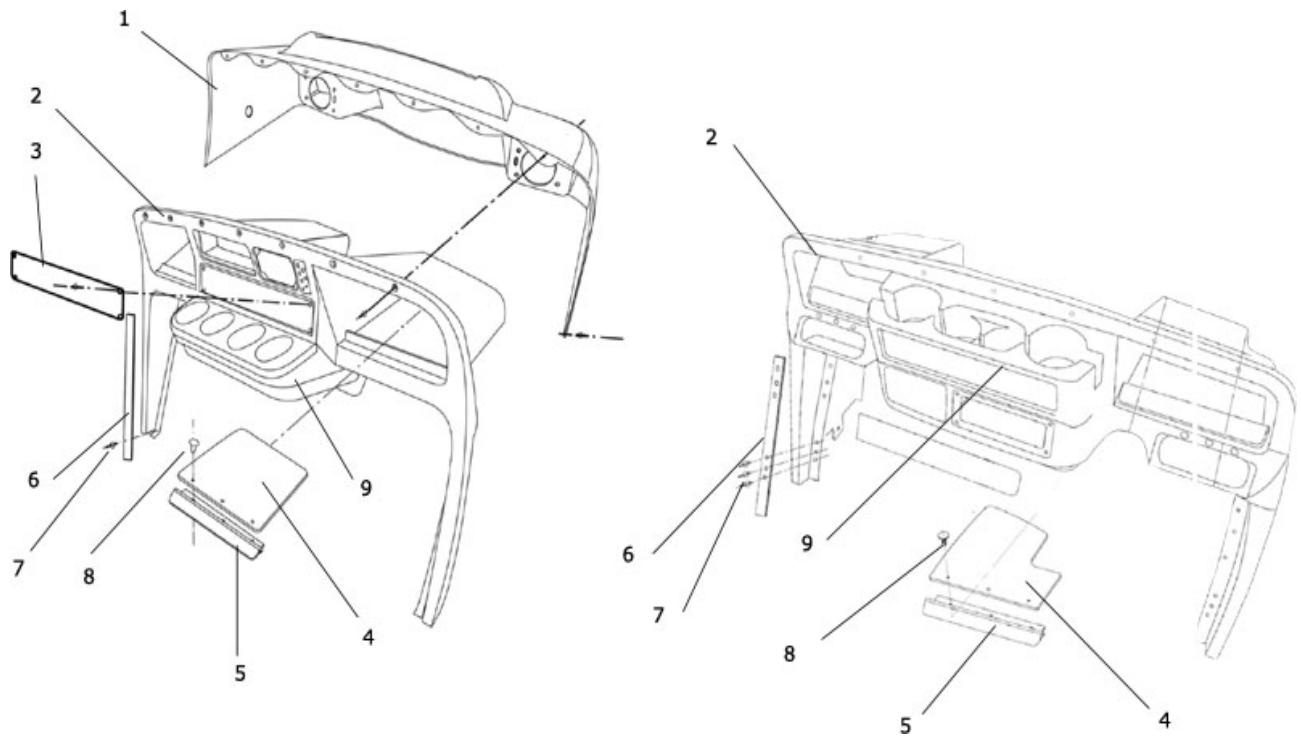

## 1-1 Front Cover (前罩)、Instrument Board (仪表盘)

Item	New Part No	Description	中文名称	Qty	Remark
1	5302010-048	Front cover	前罩	1	
2	2024-5205005	Instrument board 2024	2024 仪表台	1	plastic
	5305110-009	Instrument board 2028	2028 仪表台	1	plastic
3	5305126-009	Safety label	安全警告牌	1	Sticked
4	2024-5205003	Glove box mat	手套盒垫 2024	2	Eudipleural
	5305122-009	Glove box mat	手套盒垫 2028	2	Eudipleural

5	5305123-009	Glove box block	手套盒挡块 2024	2	Eudipleural
	5305122-009	Glove box block	手套盒挡块 2028	2	Eudipleural
6	5109011-036	Floor mat bar	地板革压条	2	
7	Q44005188	Self-tapping screw M5	开口型扁圆头抽心 铆钉 M5×18.8	2	
8		Button	按扣	6	
9	5305121-009	Cup holder	杯托	1	

## 1-2 Front windshield (前挡玻璃)

### Front Split Windshield (折叠前风挡)

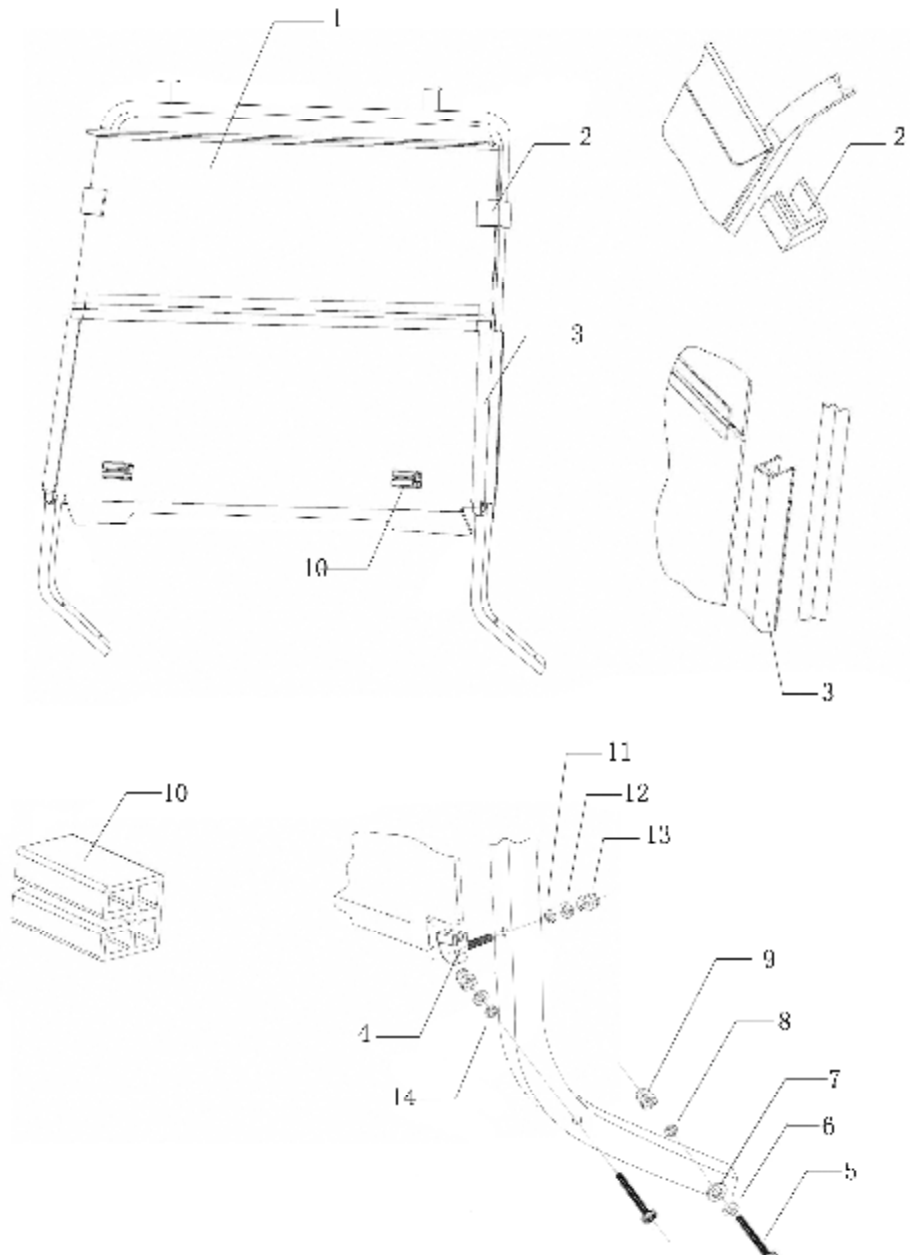

## 1-2 Front Windshield(前挡玻璃)

### Front Split Windshield (折叠前风挡)

Item	New Part No	Description	中文名称	Qty	Remark
1	5303010-015	Windshield, hinged	折叠前挡玻璃	1	2013.5.20 修改编码
2	2026-5203004	Slip block	玻璃固定夹块（卡管上方的）	2	2015.7.24 修改编码
3	5303021-012	sash for hinged windshield	玻璃夹	2	
4	2020A-5606002	Glass holding block	玻璃托块	2	
5	Q150B0890-304H	Black nickel hex bolt M8x90	黑镍六角头螺栓 M8×90	4	
6	Q40308-304H	Black nickel gasket spring M8	黑镍弹垫 M8	4	
7	Q40208-304H	Black nickel C	黑镍大垫圈 M8	4	
8	2024-5601002	spacer	小垫块	4	
9	Q394B08-304H	Black nickel operculiform nut M8	黑镍盖形螺母 M8	4	
10		Clipping block included in item 1	玻璃夹块	2	
11	Q40308-304H	Black nickel gasket spring M8	黑镍弹垫 M8	2	
12	Q40108-304H	Black nickel C	黑镍平垫圈 M8	2	
13	Q394B08-304H	Black nickel operculiform nut M8	黑镍盖形螺母 M8	2	
14	2024-5601004	spacer	隔离块	2	



# Front One-piece Windshield (非折叠前风挡)

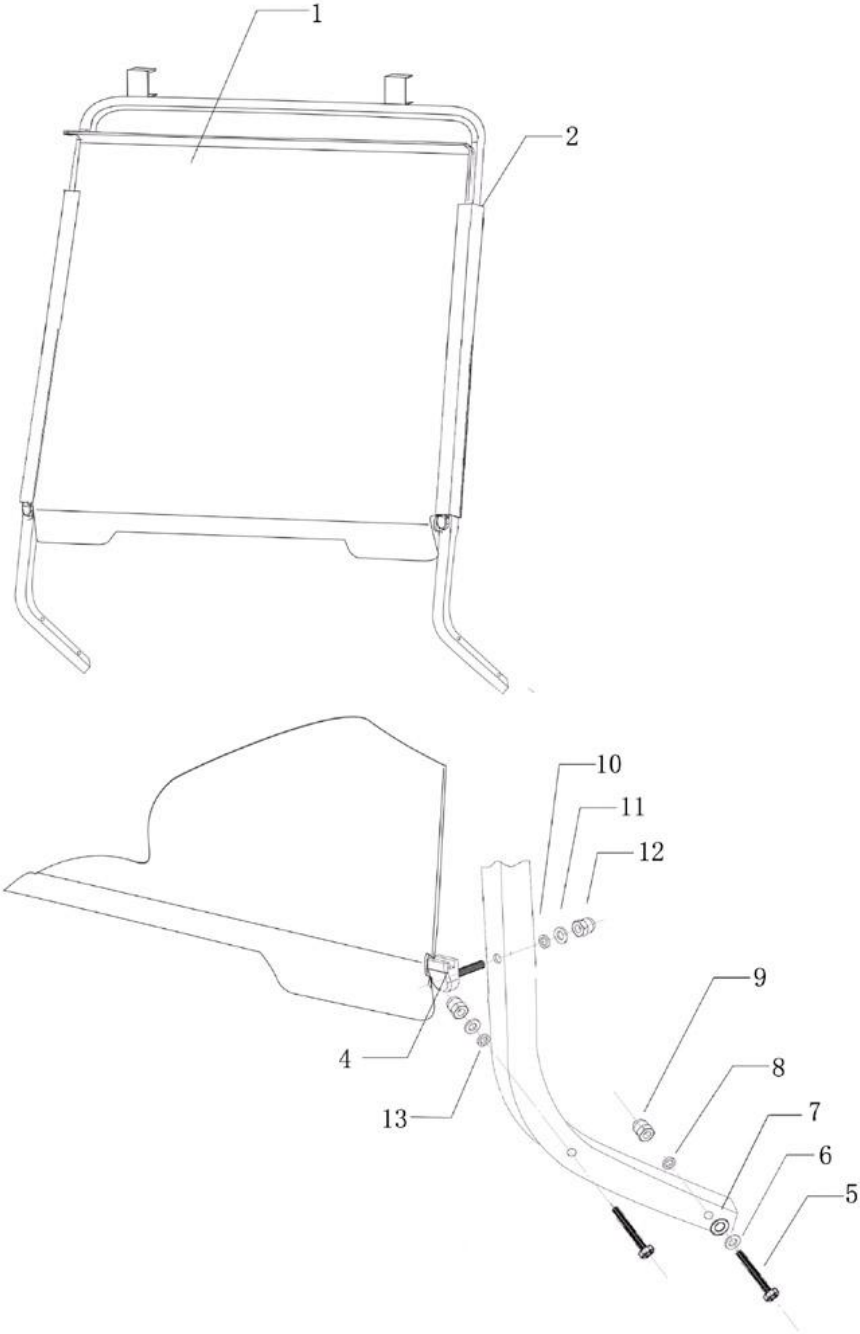



## Front One-piece Windshield (非折叠前风挡)

Item	New Part No	Description	中文名称	Qty	Remark
1	5303010-020	Windshield, one-piece	非折叠前挡玻璃	1	
2	5303021-011	sash for one-piece windshield	玻璃夹	2	
3					
4	2020A-5606002	Glass holding block	玻璃托块	2	
5	Q150B0890-304H	Black nickel hex bolt M8x90	黑镍六角头螺栓 M8×90	4	
6	Q40308-304H	Black nickel gasket spring M8	黑镍弹簧垫圈 M8	4	
7	Q40208-304H	Black nickel C	黑镍大垫圈 M8	4	
8	2024-5601002	spacer	小垫块	4	
9	Q394B08-304H	Black nickel operculiform nut M8	黑镍盖形螺母 M8	4	
10	Q40308-304H	Black nickel gasket spring M8×90	黑镍弹簧垫圈 M8	2	
11	Q40108-304H	Black nickel C	黑镍平垫圈 M8	2	
12	Q394B08-304H	Black nickel operculiform nut M8	黑镍盖形螺母 M8	2	
13	2024-5601004	spacer	隔离块	2	

**1-3 Roof (顶棚)**

**EG2020ASZ Roof (EG2020ASZ 顶棚)**

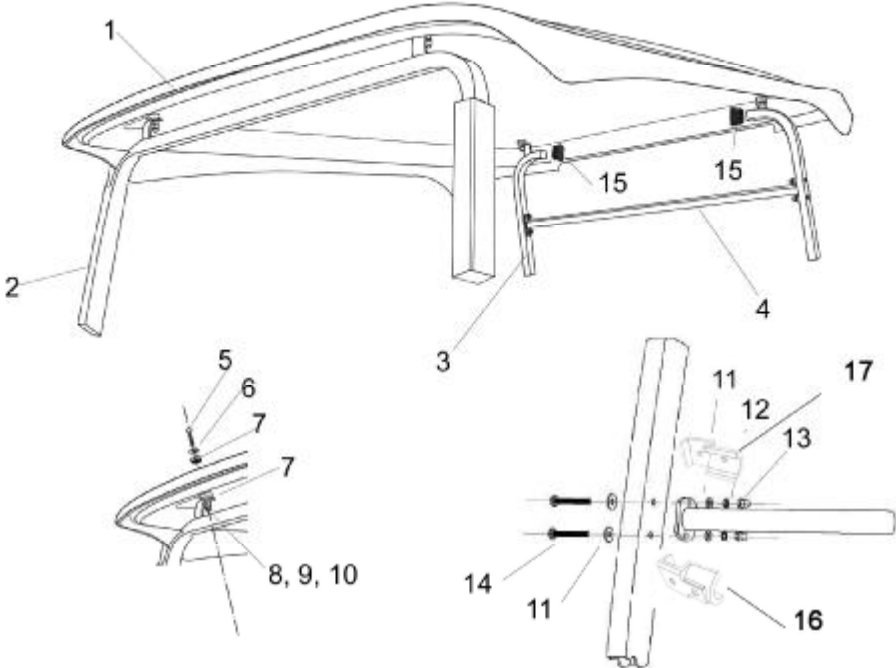

## 1-3 Roof (顶棚)

### EG2020ASZ Roof (EG2020ASZ 顶棚)

Item	New Part No	Description	中文名称	Qty	Remark
1	5702010-063	Roof (no paint)	顶棚 (无喷漆)	1	
	5702010-063-A0	Roof (3013 green)	顶棚 (3013 绿)	1	
	5702010-063-A2	Roof (pure white)	顶棚 (纯白)	1	
	5702010-063-A3	Roof (pure black)	顶棚 (纯黑)	1	
	5702010-063-A4	Roof (Coca cola red)	顶棚 (可口可乐红)	1	
	5702010-063-A10	Roof (Military camo)	顶棚 (军用迷彩)	1	
	5702010-063-A11	Roof (New camo)	顶棚 (新迷彩)	1	
	5702010-063-A1	Roof (metallic green)	顶棚 (金属绿)	1	
	5702010-063-A6	Roof (Champagne)	顶棚 (香槟色)	1	
	5702010-063-A7	Roof (Navy blue)	顶棚 (警车蓝)	1	
2	3041-5601001	Front bracket	顶棚前支架	1	
3	5701021-063	Rear bracket	顶棚后立柱	2	
4	5701023-055	Caddie handle	球童拉手	1	
5	Q150B0845-304H	Black nickel hex bolt M8x45	黑镍六角头螺栓 M8x45	4	
6	Q40208-304H	Black nickel gasket M8	黑镍大垫圈 M8	4	
7		spacer M8	小垫块 M8	12	
8	Q40108-304H	Black nickel gasket M8	黑镍平垫圈 M8	4	
9	Q40308-304H	Black nickel spring gasket M8	黑镍弹簧垫圈 M8	4	
10	Q394B08-304H	Black operculiform nut M8	黑镍盖形螺母 M8	4	
11	Q40006-304H	Black nickel gasket M6	黑镍平垫 M6	8	
12	Q40306-304H	Black nickel gasket M6	黑镍弹垫 M6	4	
13	Q384B06-304H	Black operculiform nut M8	黑镍盖形螺母 M6	4	
14	Q2140640-304H	Black Cross slot annex screw M6x40	黑镍十字槽盘头螺钉 M6x40	4	
15	2024-5606004	Canopy bracket cap	端盖-方管堵块	2	
16	5701041-036	#1 jacket for caddie handle	#1 球童拉手夹套	2	
17	5701042-036	#2 jacket for caddie handle	#2 球童拉手夹套	2	

# EG2040ASZ Roof (EG2040ASZ 顶棚)

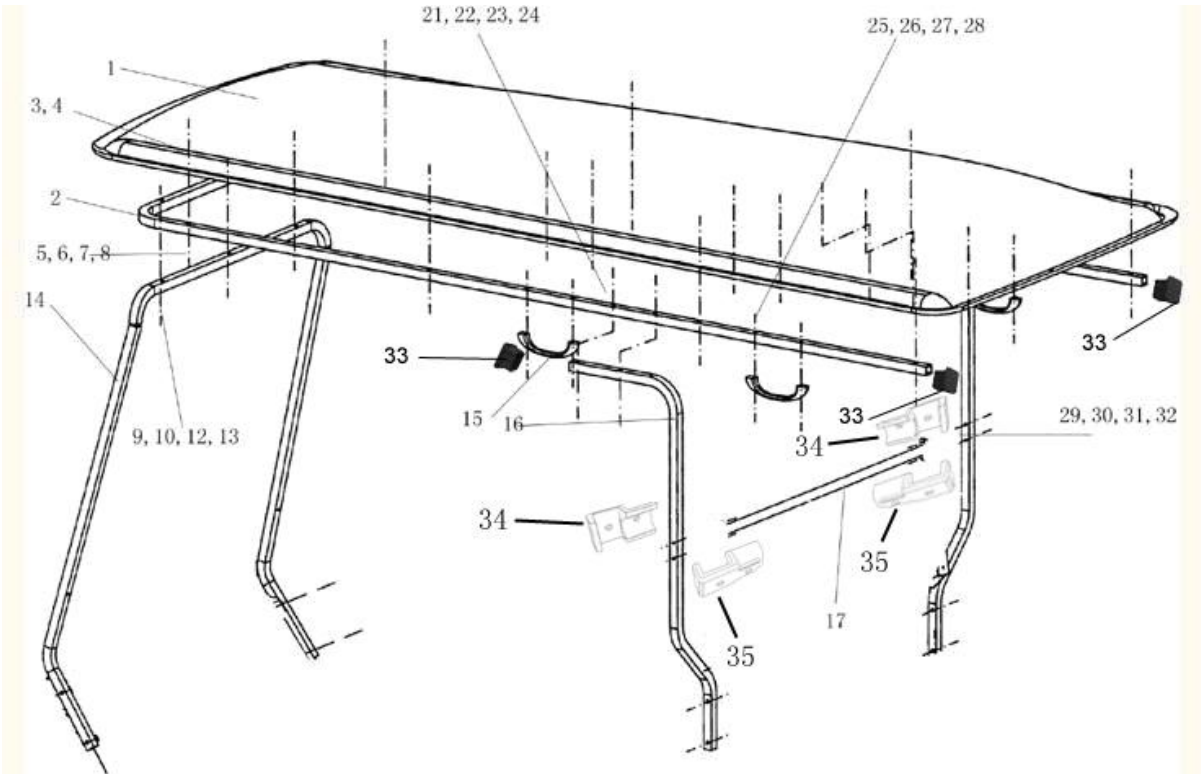

## EG2040ASZ Roof (EG2040ASZ 顶棚)

Item	New Part No	Description	中文名称	Qty	Remark
1	5702010-045-A0	Canopy (Pure white)	顶棚 (纯白)	1	
	5702010-045-A6	Canopy (3013 green)	顶棚 (3013 绿)	1	
	5702010-045-A9	Canopy (Coca cola red)	顶棚 (可口可乐红)	1	
	5702010-045-A8	Canopy (Pure black)	顶棚 (纯黑)	1	
	5702010-045-A7	Canopy (Metallic green)	顶棚 (金属绿)	1	
	5702010-045-A11	Canopy (Champagne)	顶棚 (香槟色)	1	
	5702010-045-A13	Canopy (Navy blue)	顶棚 (警蓝)	1	
2	5701061-040	upper bracket	顶棚上支架	1	
3	Q150B0865-304H	M8×65	六角头螺栓 M8×65	8	
4	Q40208-304H	Black nickel gasket spring M8	黑镍弹垫 M8	8	
5	2024-5601002	rubber cushion	小垫块(橡胶垫)	24	
6	Q40208-304H	Black nickel big gasket M8	大垫圈 M8	8	
7	Q40108-304H	Black nickel gasket M8	黑镍平垫 M8	8	
8	Q394B08-304H	Black nickel operculiform nut M8	黑镍盖形螺母 M8	8	
9	Q150B0865-304H	Black nickel bolt M8×65	六角头螺栓 M8×65	3	
10	Q40108-304H	Black nickel gasket M8	黑镍平垫 M8	6	
12	Q40308-304H	Black nickel gasket spring M8	黑镍弹垫 M8	3	
13	Q394B08-304H	Black nickel operculiform nut M8	黑镍盖形螺母 M8	3	
14	2044-5601001	Front bracket (Carbon steel)	顶棚前支架(碳钢)	1	
	2044-5601001A	Front bracket (STS)	顶棚前支架(不锈钢)	1	
15	5708010-014	Roof handle	顶棚拉手	5	
16	5701021-054	Rear bracket(Carbon Steel)	顶棚后立柱(碳钢)	2	Eudipleural
	5701021-055	Rear bracket (STS)	顶棚后立柱(不锈钢)	2	Eudipleural
17	5701031-047	Caddie handle(Carbon Steel)	球童拉手(碳钢)	1	
	5701031-048	Caddie handle(STS)	球童拉手(不锈钢)	1	
21	Q150B0865-304H	Black nickel bolt M8×65	六角头螺栓 M8×65	4	
22	Q40208-304H	Black nickel big gasket M6	大垫圈 M8	4	
23	Q40108-304H	Black nickel gasket M8	黑镍平垫 M8	8	
24	Q394B08-304H	Black nickel operculiform nut M8	黑镍盖形螺母 M8	4	
25	Q2140640-304H	Black nickel bolt M6×40	黑镍十字槽盘头螺钉 M6×40	10	

26	Q40206-304H	Black nickel big gasket M6	大垫圈 M6	10	
27	Q40306-304H	Black nickel gasket spring M6	黑镍弹垫 M6	10	
28	Q360B06	Hex nut M6	2 型六角螺母 M6	10	
29	Q2140640-304H	Black nickel bolt M6×40	黑镍十字槽盘头螺钉 M6×40	4	
30	Q40006-304H	Black nickel gasket M6	黑镍平垫 M6	8	
31	Q40306-304H	Black nickel gasket spring M6	黑镍弹垫 M6	4	
32	Q394B06-304H	Black nickel operculiform nut M6	黑镍盖形螺母 M6	4	
33	2024-5606004	Canopy bracket cap	端盖-方管堵块	4	
34	5701041-036	#1 jacket for caddie handle	#1 球童拉手夹套	2	
35	5701042-036	#2 jacket for caddie handle	#2 球童拉手夹套	2	

# 1-4 Top Basket (顶 篮)

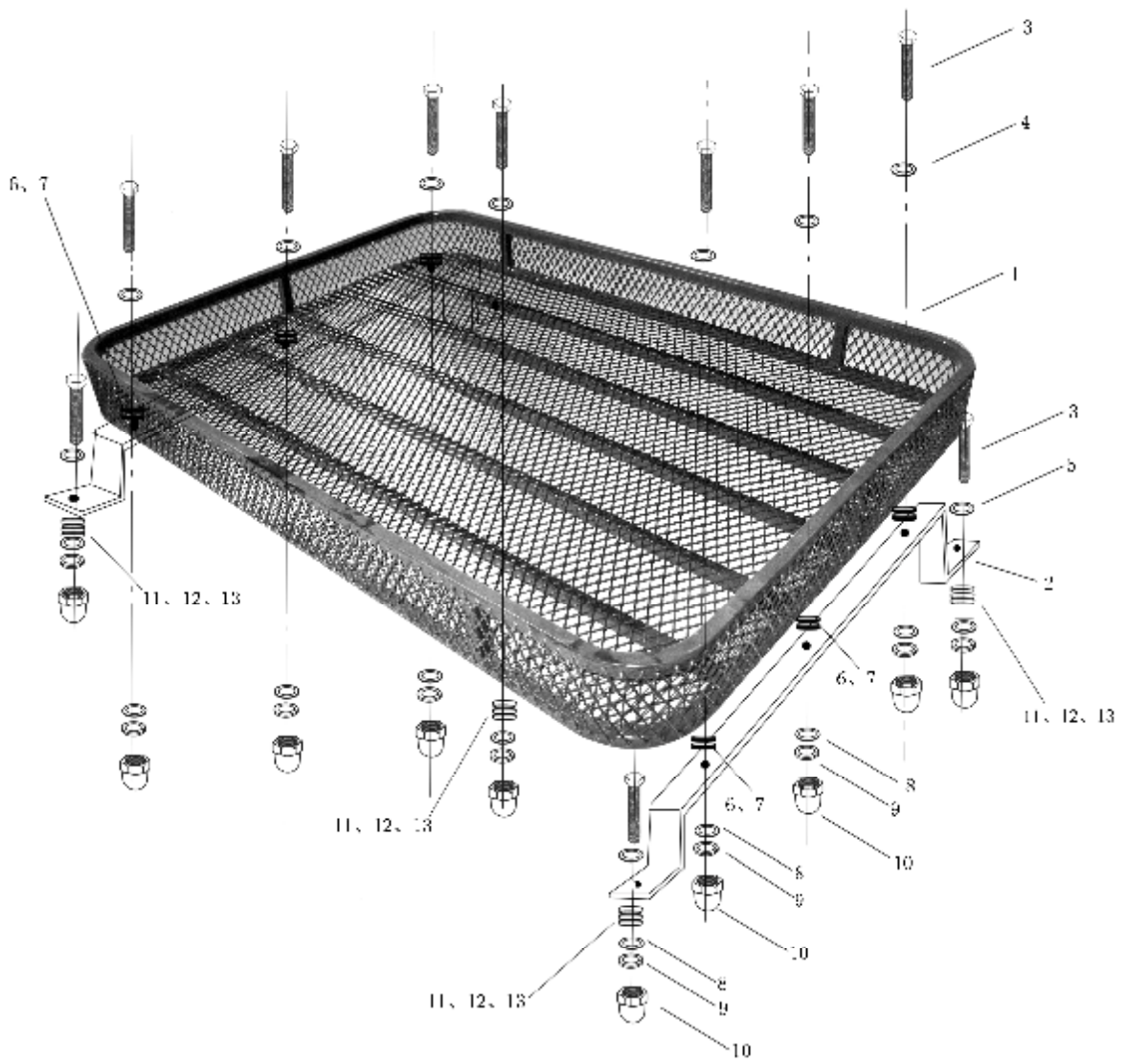

## 1-4 Top Basket (顶 篮)

Item	New Part No	Description	中文名称	Qty	Remark
1	5702100-048	Top basket	顶 篮	1	
2	5702020-048	Top basket bracket	顶篮支架	2	
3	Q150B0850-304H	Black nickel hex bolt M8×50	黑镍六角头螺栓 M8×50	10	
4	Q40108-304H	Black nickel gasket M8	黑镍平垫圈 M8	6	
5	Q40208-304H	Black nickel big gasket M8	黑镍大垫圈 M8	4	
6、7		Rubber cushion	小垫块 (橡胶垫)	12	
8	Q40108-304H	Black nickel gasket M8	黑镍平垫圈 M8	10	
9	Q40308-304H	Black nickel gasket spring M8	黑镍弹簧垫圈 M8	10	
10	Q394B08-304H	Black nickel operculiform nut M8	黑镍盖形螺母 M8	10	
11		Rubber cushion	小垫块 (橡胶垫)	12	



1-5 Front Basket (前 籃)

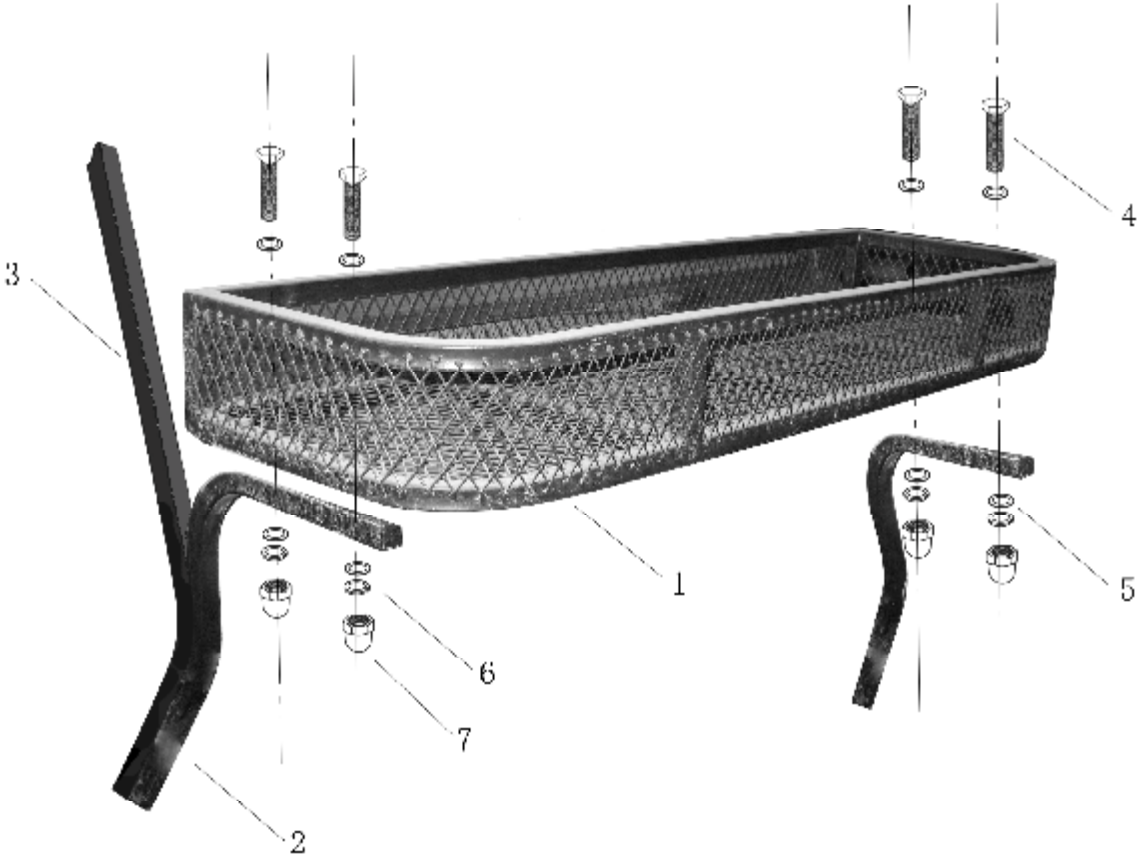

## 1-5 Front Basket (前 篮)

Item	New Part No	Description	中文名称	Qty	Remark
1	5302100-048	Front basket	前 篮	1	
2	5302030-048	Front basket bracket	前篮支架	2	
3	3041-5601001	Front bracket	前顶棚支架	1	
4	Q150B0855-304H	Black nickel bolt M8×55	黑镍六角头螺栓 M8×55	4	
5	Q40108-304H	Black nickel gasket M8	黑镍平垫圈 M8	4	
6	Q40308-304H	Black nickel gasket spring M8	黑镍弹簧垫圈 M8	4	
7	Q394B08-304H	Black nickel operculiform nut M8	黑镍盖形螺母 M8	4	

# 1-6 Rear Standing Board, Rear Standing Board Handrail, Flip-flop Seat

(后站板、后站板扶手、折叠座椅总成)

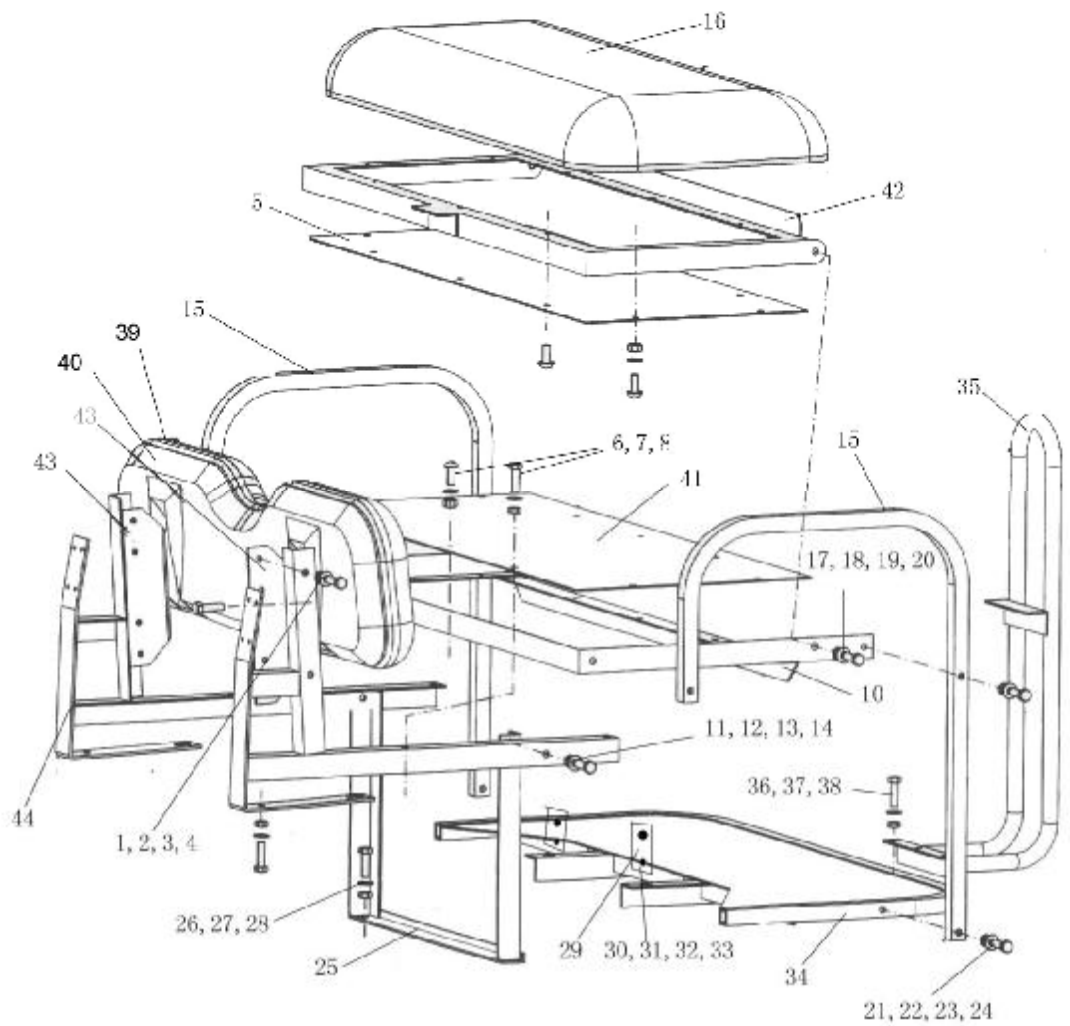

## 1-6 Rear Standing Board, Rear Standing Board Handrail, Flip-flop Seat (后站板、后站板扶手、折叠座椅总成)

Item	New Part No	Description	中文名称	Qty	Remark
1	Q150B0845-304H	Black nickel bolt M8×45	六角头螺栓 M8×45	4	
2	Q40108-304H	Black nickel gasket M8	黑镍平垫 M8	8	
3	Q40308-304H	Black nickel gasket spring M8	黑镍弹垫 M8	4	
4	Q394B08-304H	Black nickel operculiform nut M8	黑镍盖形螺母 M8	4	
5	5401181-037	Aluminum plate under cushion	座垫铝板	1	
6	Q2140830-304H	Black nickel bolt M8×30	黑镍十字槽盘头螺钉 M8×30	4	
7	Q40208-304H	Black nickel big gasket M8	大垫圈 M8	8	
8	Q340B08-304H	Black nickel operculiform nut M8	1型六角头螺母 M8	4	
9	Q273	Cross groove Half head screw	蓝白十字槽大半圆头自攻钉	14	
10	2026KSZ-7102045-004	Flip-flop bracket	翻转支架	1	
11	Q150B1030	Black nickel bolt M10×30	六角头螺栓 M10×30	4	
12	Q40110-304H	Black nickel gasket M10	黑镍平垫 M10	4	
13	2042-7102048	Copper sleeve	铜套	2	
14	Q394B10-304H	Black nickel operculiform nut M10	黑镍盖形螺母 M10	4	
15	5401141-037	Side armrest	侧扶手	2	
16	7120100-037	Assembly of Cushion	折叠座椅坐垫	1	
17	Q150B0840-304H	Black nickel bolt M8×40	六角头螺栓 M8×40	4	
18	Q40108-304H	Black nickel gasket M8	黑镍平垫 M8	8	
19	Q40308-304H	Black nickel gasket spring M8	黑镍弹垫 M8	4	
20	Q394B08-304H	Black nickel operculiform nut M8	黑镍盖形螺母 M8	4	
21	Q150B0865-304H	Black nickel bolt M8×65	六角头螺栓 M8×65	4	
22	Q40108-304H	Black nickel gasket M8	黑镍平垫 M8	8	
23	Q40308-304H	Black nickel gasket spring M8	黑镍弹垫 M8	4	
24	Q32608	Hex lock nut M8	2型非金属嵌件六角锁紧螺母 M8	4	
25	5401130-037	Seat frame	座椅底支架	1	

26	Q2140845-304H	Black nickel bolt M8×45	黑镍十字槽盘头螺钉 M8×45	2	
27	Q40208-304H	Black nickel big gasket M8	大垫圈 M8	4	
28	Q32608	Hex lock nut M8	2型非金属嵌件六角琐紧螺母 M8	2	
29	5402121-037	Shackle plate	吊耳片	2	
30	Q150B1030	Black nickel bolt M10×30	六角头螺栓 M10×30	2	
31	Q40110-304H	Black nickel gasket M10	黑镍平垫 M10	4	
32	Q40310-304H	Black nickel gasket spring M10	黑镍弹垫 M10	2	
33	Q340B10-304H	Black nickel operculiform nut M10	1型六角头螺母 M10	2	
34	5402110-037	Rear Standing board	折叠座椅站板	1	
35	2026KSZ-7101020-002	Rear standing board handrail	后站板扶手	1	
36	Q150B0845-304H	Black nickel bolt M8×45	六角头螺栓 M8×45	2	
37	Q40208	Black nickel big gasket M8	大垫圈 M8	4	
38	Q32608	Black nickel operculiform nut M10	2型非金属嵌件六角琐紧螺母 M8	2	
39	2024-6501022	EG2024K Backrest cushion	2024 靠背垫	1	
	7106100-036	EG2028K Backrest cushion	2028 靠背垫	1	
40	2024-6501023	EG2024K Backrest cover (plastic)	2024 靠背罩(塑料)	1	
	2024-6501023-101	EG2024K Backrest cover (timber)	2024 靠背罩(桃木)	1	
	7106111-036	EG2028K Backrest cover (plastic)	2028 靠背罩(塑料)	1	
	7106111-036-A1	EG2028K Backrest cover (timber)	2028 靠背罩(桃木)	1	
41	2026KSZ-7102046-004	Aluminum plate on flip-flop bracket	翻转支架铝板	1	
42	5401170-037	Cushion bracket	座垫支架	1	
43	7127011-037	Seat back sub-bracket	折叠座椅靠背支架	2	Eudipleural
44	5401110-037	Seat back main bracket	座椅主支架	1	

**1-7 Side Rear View Mirror (后视镜)**

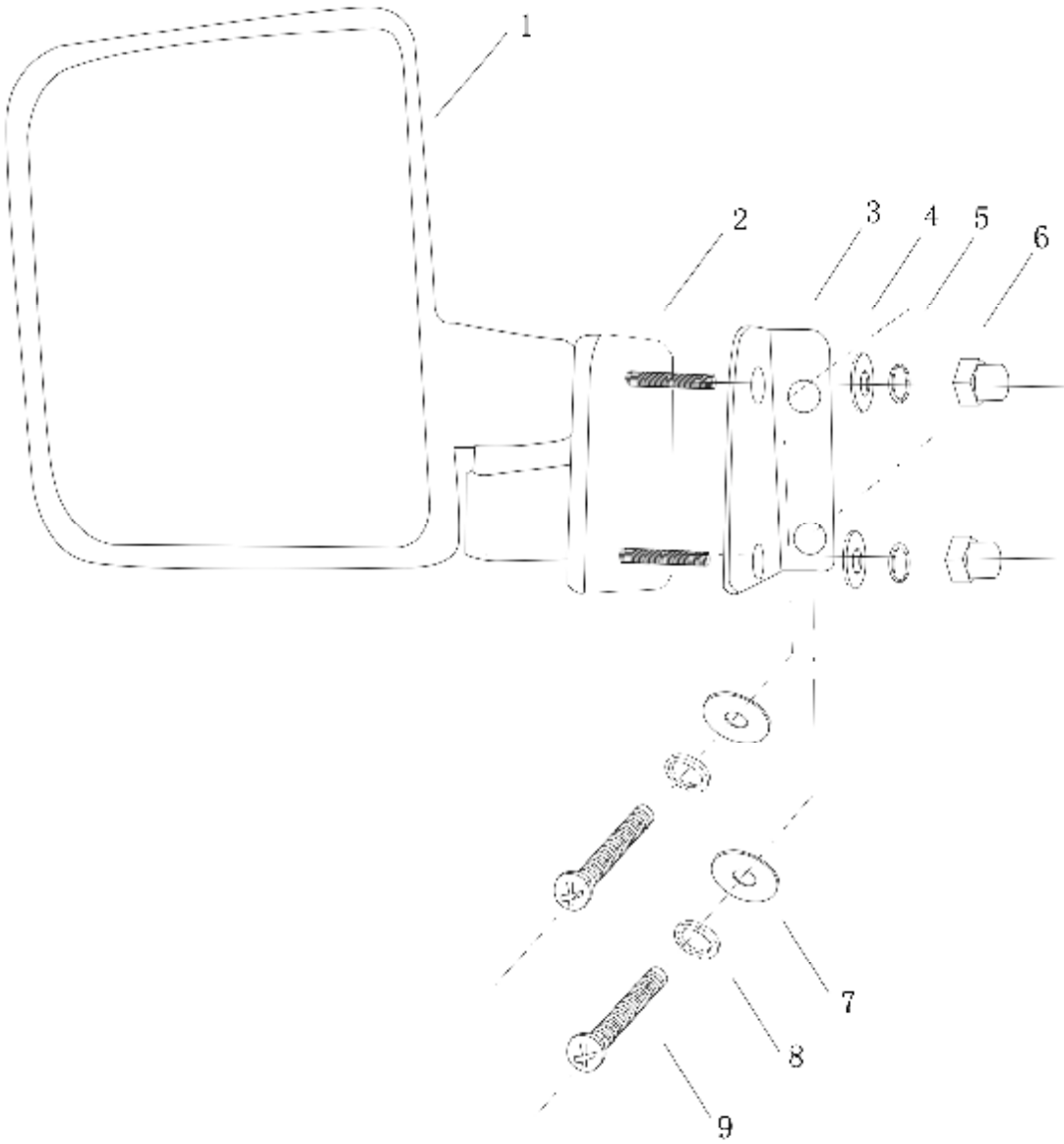

## 1-7 Side Rear View Mirror (后视镜)

Item	New Part No	Description	中文名称	Qty	Remark
1	9002100-009	Side rear view mirror	侧后视镜	2	Eudipleural
2	9002011-010	Side rear view mirror bracket	侧后视镜支架	2	Eudipleural
3		Side rear view mirror bass	侧后视镜底座	2	Eudipleural
4	Q40106-304H	Black nickel gasket M6	黑镍平垫圈 M6	2	
5	Q40306-304H	Black nickel gasket spring M6	黑镍弹簧垫圈 M6	2	
6	Q394B06-304H	Black nickel operculiform nut M6	黑镍盖形螺母 M8	2	
7	Q40106-304H	Black nickel gasket M6	黑镍平垫圈 M6	2	
8	Q40306-304H	Black nickel gasket spring M6	黑镍弹簧垫圈 M6	2	
9	Q2710620	Black nickel screw M6x20	黑镍十字槽盘头自攻螺钉—C 型 M6x20	2	

1-8 Wheel Trim (轮眉)

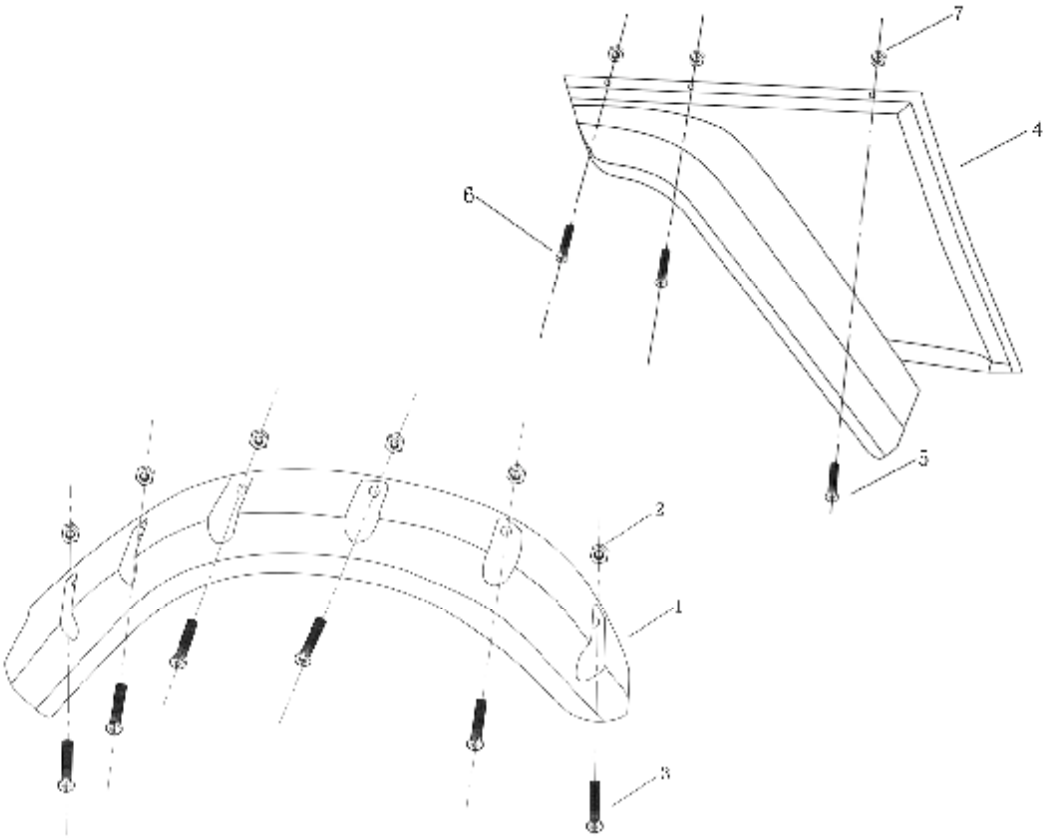



## 1-8 Wheel Trim (轮眉)

Item	New Part No	Description	中文名称	Qty	Remark
1	<b>5402061-048</b>	Rear wheel trim	后轮轮眉	2	Eudipleural
2	<b>Q360B04-304H</b>	Hex nut	2 型六角螺母	12	
3	<b>Q2710416-304H</b>	Black nickel cross recessed pan head tapping screws	黑镍十字槽盘头自攻螺钉	12	
4	<b>5302013-048</b>	Front wheel trim	前轮轮眉	2	Eudipleural
5	<b>Q2730415-304H</b>	Black nickel cross recessed half-round head tapping screws	黑镍十字槽大半圆头自攻螺钉	2	
6	<b>Q271Q0416-304H</b>	Black nickel cross recessed pan head tapping screws	黑镍十字槽盘头自攻螺钉	4	
7	<b>Q360B04-304H</b>	Hex nut	2 型六角螺母	4	

5302013-048 5402061-048 2015-9-16 王小波修改

**1-9 Seat Back, Seat Cushion (靠背, 坐垫)**

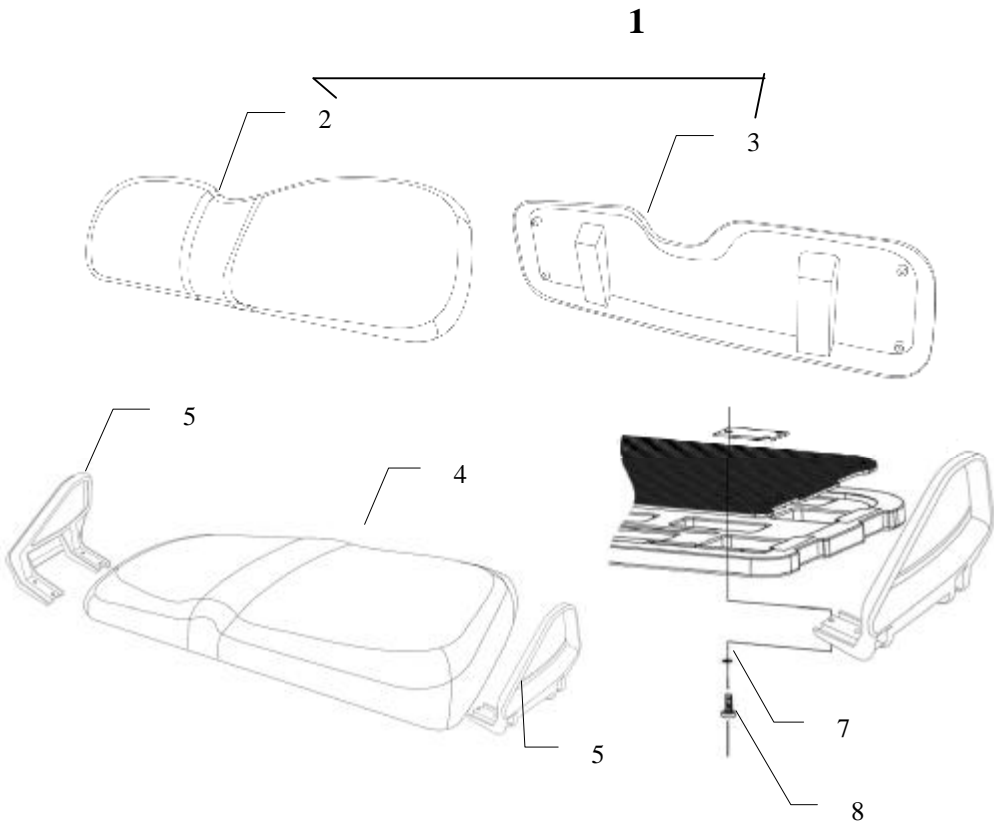

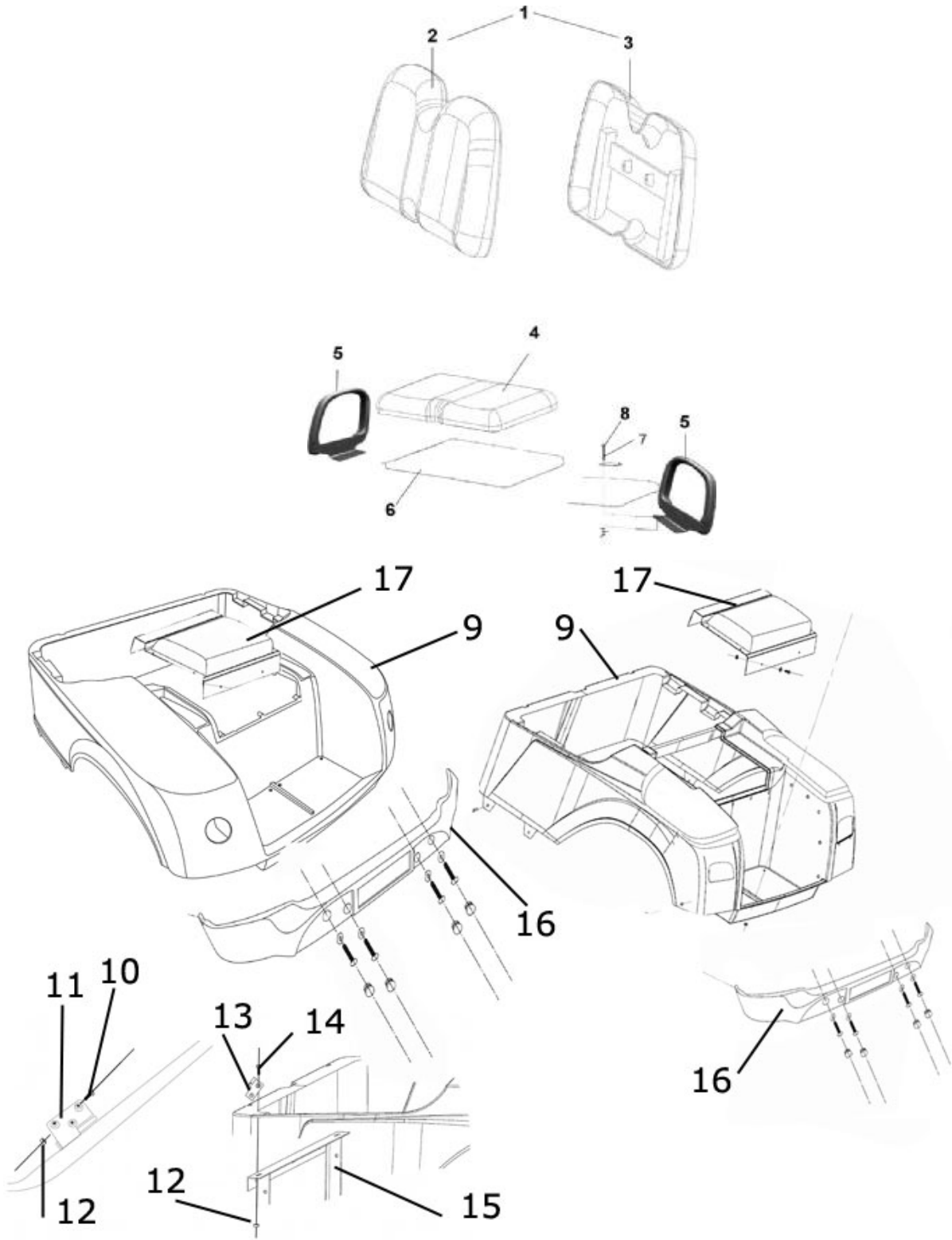

## 1-9 Seat Back, Seat Cushion (靠背, 坐垫)

Item	New Part No	Description	中文名称	Qty	Remark
1		EG2028K Backrest assembly(include 2,3)	2028 靠背总成(含2,3)	2	
		EG2024K Backrest assembly(include 2,3)	2024 靠背总成(含2,3)	2	
2	7106100-036	Seat back cushion	靠背垫	2	
	2024-6501022	Seat back cushion	靠背垫	2	
3	2028-6501023	Seat back cover	靠背罩	2	plastic
	2024-6501023	Seat back cover	靠背罩	2	plastic
4	7101100-036	Seat cushion assembly	坐垫总成	1	
	2024-6501005	Seat cushion assembly	2024 坐垫总成	1	
5	7109100-036	Armrest	座椅扶手	2	
	2024-6501015	Armrest	2024 座椅扶手	2	
6	2028-6501014	Seat cover(plastic)	座椅底板(塑料)	1	for EG2028K seat
7	Q40206-304H	Black nickel gasket M6	黑镍大平垫 M6	12	
8	Q2620630	Blue nickel cross recessed pan head tapping screws 6x30	蓝锌十字槽盘头自攻锁紧螺钉 6×30	12	
9	5402010-050	Rear cover	后罩	1	
	5402010-036	Rear cover	后罩	1	
10	Q2620625	Blue nickel cross recessed pan head tapping screws 6x25	蓝锌十字槽盘头自攻锁紧螺钉 6×25		
11	2026-6501018	Upside piece of gemel	座椅铰链上板	2	
12	Q32606	Hex lock nut M6	2 型非金属嵌件六角锁紧螺母 M6	4	
13	2026-6501017	Underside piece of gemel	座椅铰链下板	2	
14	Q2620625	Cross recessed pan head tapping screws 6x25	十字槽盘头自攻锁紧螺钉 M6×25	4	
15	5111030-023	Seat frame	座椅支架	1	
16	5406110-020	Rear bumper 2024	2024 后保险杠	1	
	5406110-010	Rear bumper 2028	2028 后保险杠	1	
17	2024-5501002	Motor Access	电机检修盖板	1	
	5402041-036	Motor Access	电机检修盖板	1	

**1-10 First row of seat (前排座椅)**

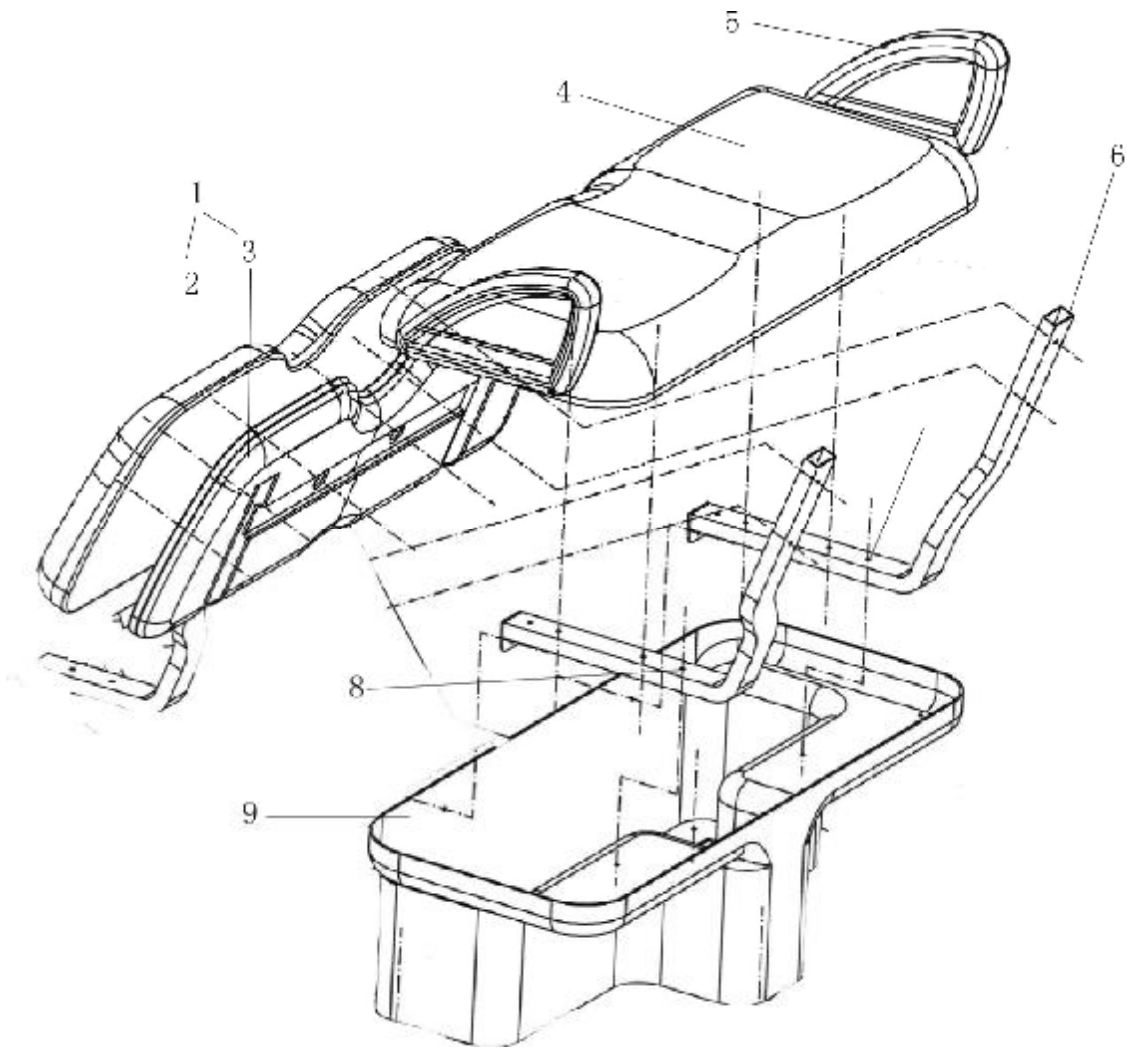

## 1-10 First row of seat (前排座椅)

Item	New Part No	Description	中文名称	Qty	Remark
1	2028-6501020	Assembly of seat back	靠背总成	1	
2	7106100-036	Backrest cushion	靠背垫	1	old
	2024-6501022	Backrest cushion	靠背垫	1	
3	2028-6501023	Backrest cover (plastic)	靠背罩 (塑料)	1	old old
	7106111-036-A1	Backrest cver (timber)	靠背罩 (桃木)	1	
	2024-6501023	Seat back cover (plastic)	靠背罩 (塑料)	1	
	2024-6501023-101	Seat back cover (timber)	靠背罩 (桃木)	1	
4	2044-6504007	Front row of cushion	前排坐垫	1	
	7101100-040	Assembly of Cushion	前排坐垫	1	
5	7109100-036	Arm rest	座椅扶手	2	
6	2044-6501004	Seat back supporting bracket	前排靠背支架	2	
7			球窝	2	
8	2701220-008	Seat ball	座椅球头	2	
9	5302021-040	Front seat compartment (no paint)	前排座椅桶(无油漆)	1	
	5302021-040-A0	Front seat compartment (3013 green)	前排座椅桶(3013 绿)	1	
	5302021-040-A3	Front seat compartment (Pure white)	前排座椅桶(纯白)	1	
	5302021-040-A4	Front seat compartment (Pure black)	前排座椅桶(纯黑)	1	
	5302021-040-A5	Front seat compartment (Coca cola red)	前排座椅桶(可口可乐红)	1	
	5302021-040-A1	Front seat compartment (Metallic green)	前排座椅桶(金属绿)	1	
	5302021-040-A7	Front seat compartment (Champagne)	前排座椅桶(香槟色)	1	
	5302021-040-A9	Front seat compartment (Navy blue)	前排座椅桶(警车色)		

### 1-11 Front metallic bumper (前碳钢保险杠)

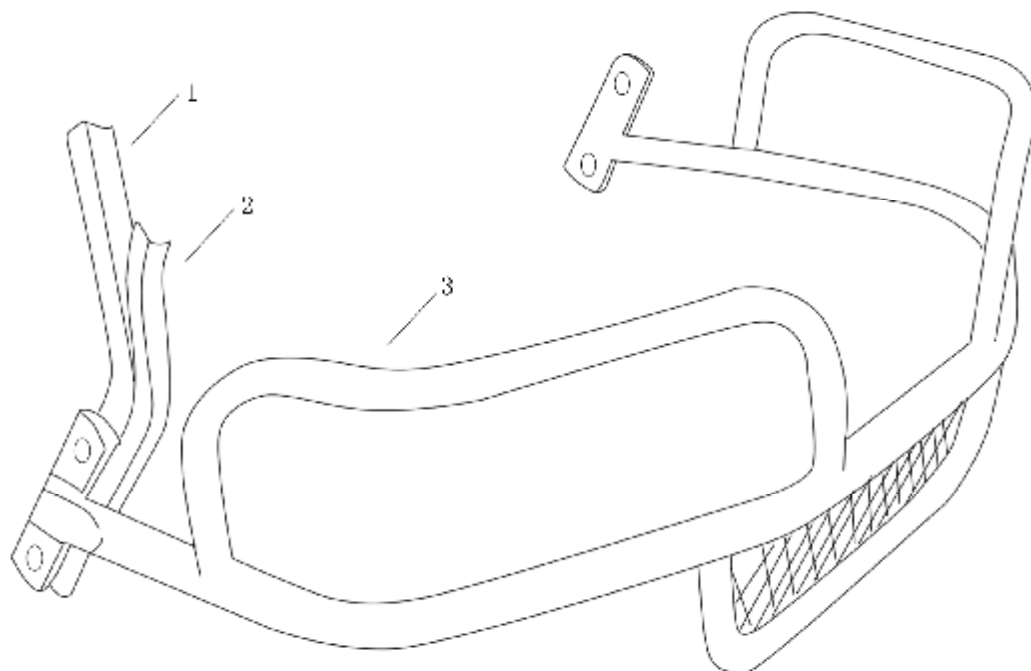

### 1-11 Front metallic bumper (前碳钢保险杠)

Item	Part No	Description	中文名称	Qty
1		Front bracket	顶篷前支架	1
2	3041-5601002	Front basket bumper	前篮支架	2
3	3040-5207010	Front bumper	前保险杠	1

## 1-12 Front plastic bumper (前塑料保险杠)

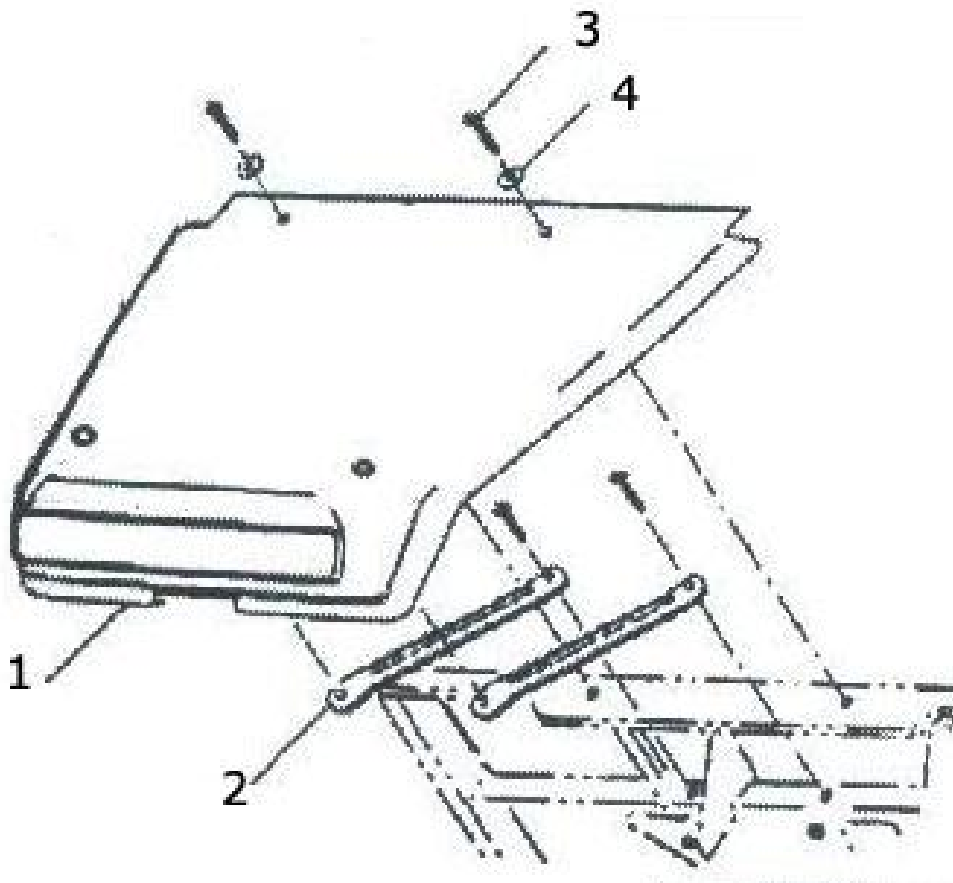

## 1-12 Front plastic bumper (前塑料保险杠)

Item	New Part No	Description	中文名称	Qty	Remark
1	5307110-008	Front plastic bumper	前塑料保险杠	1	
2	5307131-008	Front plastic bracket	前塑料保险杠支架	2	
3		Bolt	螺栓	2	
4		Gasket	垫片	2	



2-1 Frame, Floor, Side Trim (车架总成、地板、侧护板)

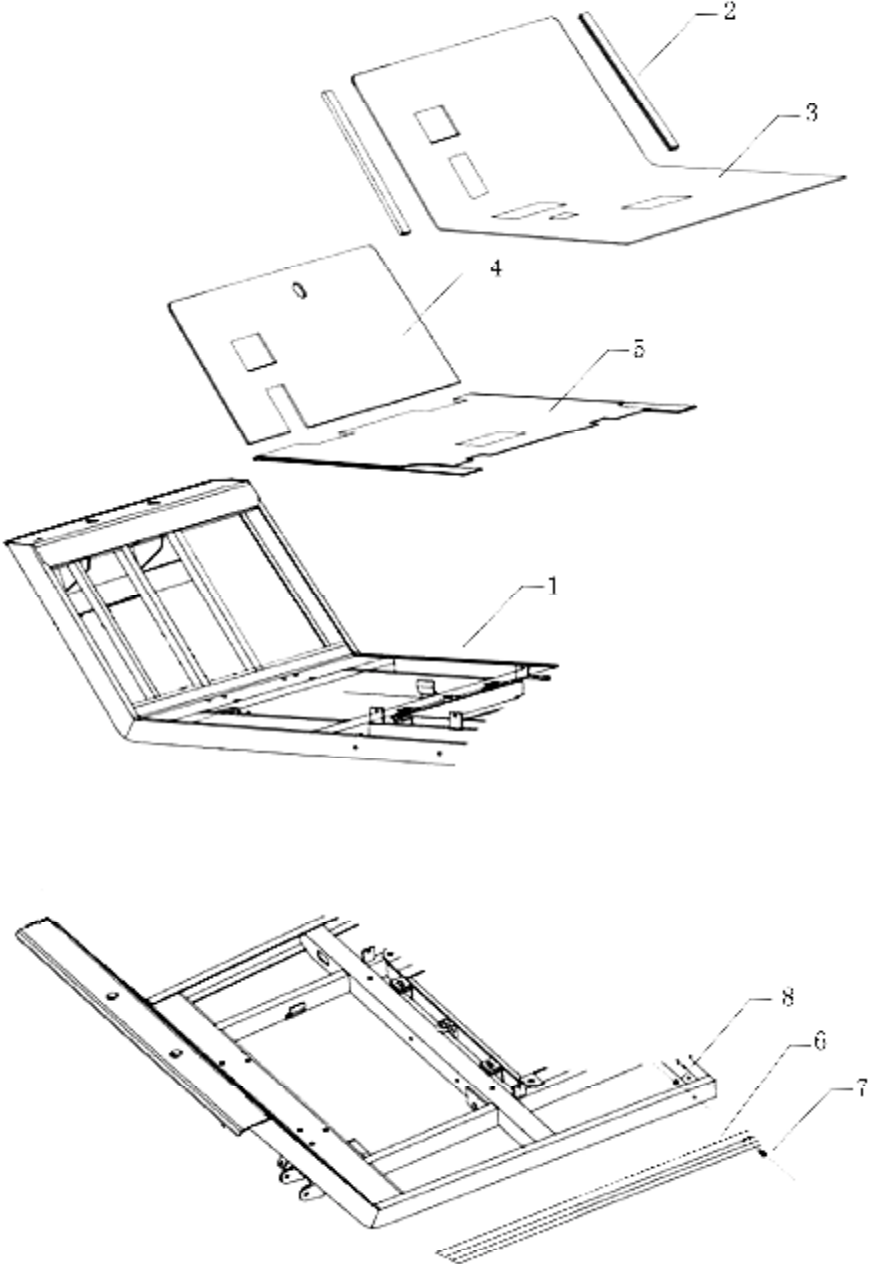

## 2-1 Frame, Floor, Side Trim (车架总成、地板、侧护板)

1		Frame	车架总成	1	
2	5109011-036	Floor mat press bar	地板革压条	2	Eudipleural
3	2028-5106006	EG2020ASZ Floor mat	2020ASZ 地板革	1	EG2020ASZ
	5107010-040	EG2040ASZ Floor mat	2040ASZ 地板革	1	EG2040ASZ
4	5102011-036	Front fender	前挡板	1	
5	5102012-036	EG2020ASZ Floor board	2020ASZ 下底板	1	
	5102012-040	EG2040ASZ Floor board	2040ASZ 下底板	1	
6	5502110-037	EG2020ASZ Side trim	EG2020ASZ 侧护板	2	Eudipleural
	5602110-041	EG2040ASZ Side trim	EG2040ASZ 侧护板	2	Eudipleural
7	Q2710640	Cross recessed pan head tapping screws M6×40	十字槽盘头自攻螺钉 M6×40	4	
8	Q360B06	Hex nut	2 型六角螺母	4	
9	5111100-023	Battery compartment	电池框	1	metal

### 3-1 Braking Pedal & Bracket Assembly(制动踏板及支架总成)

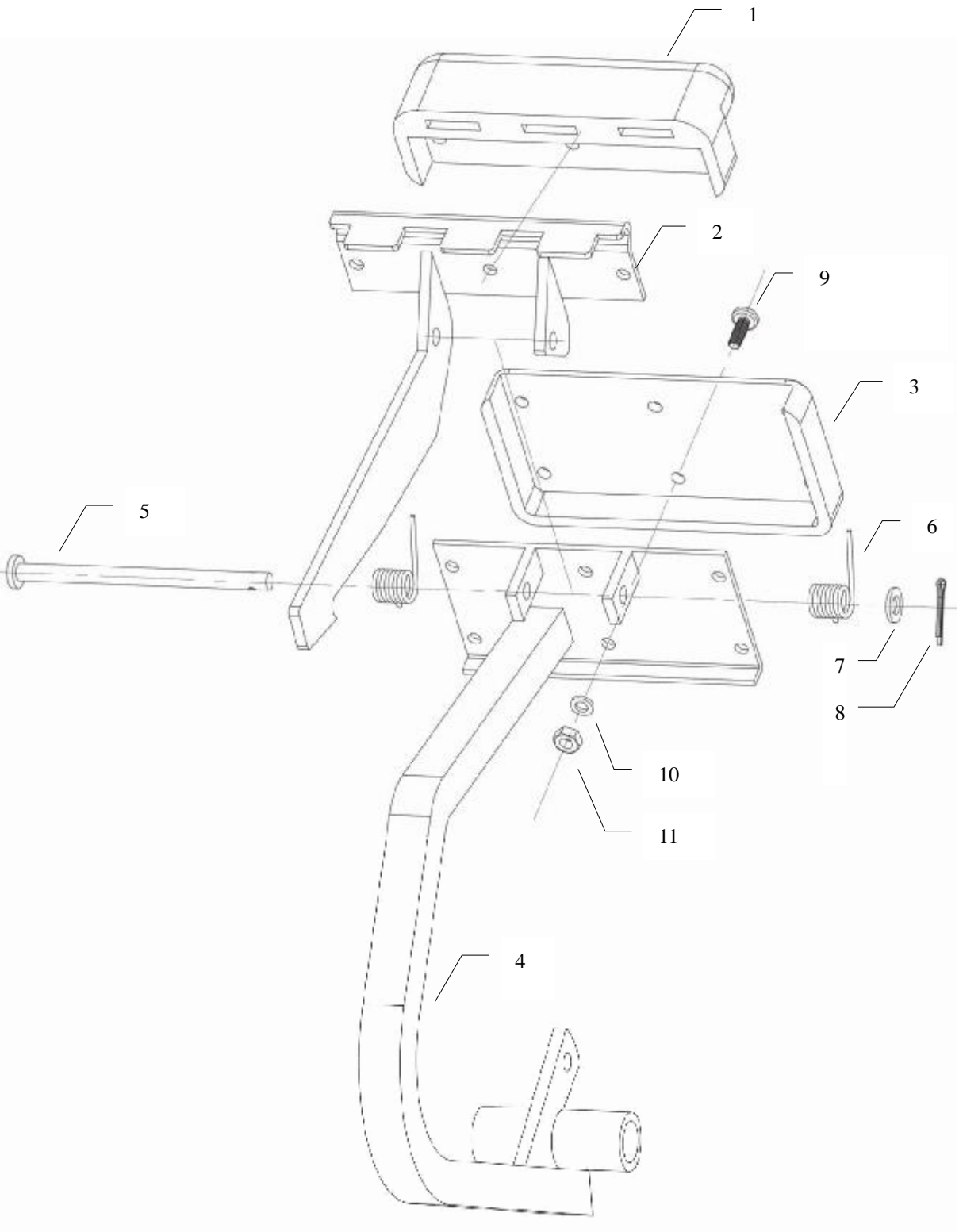

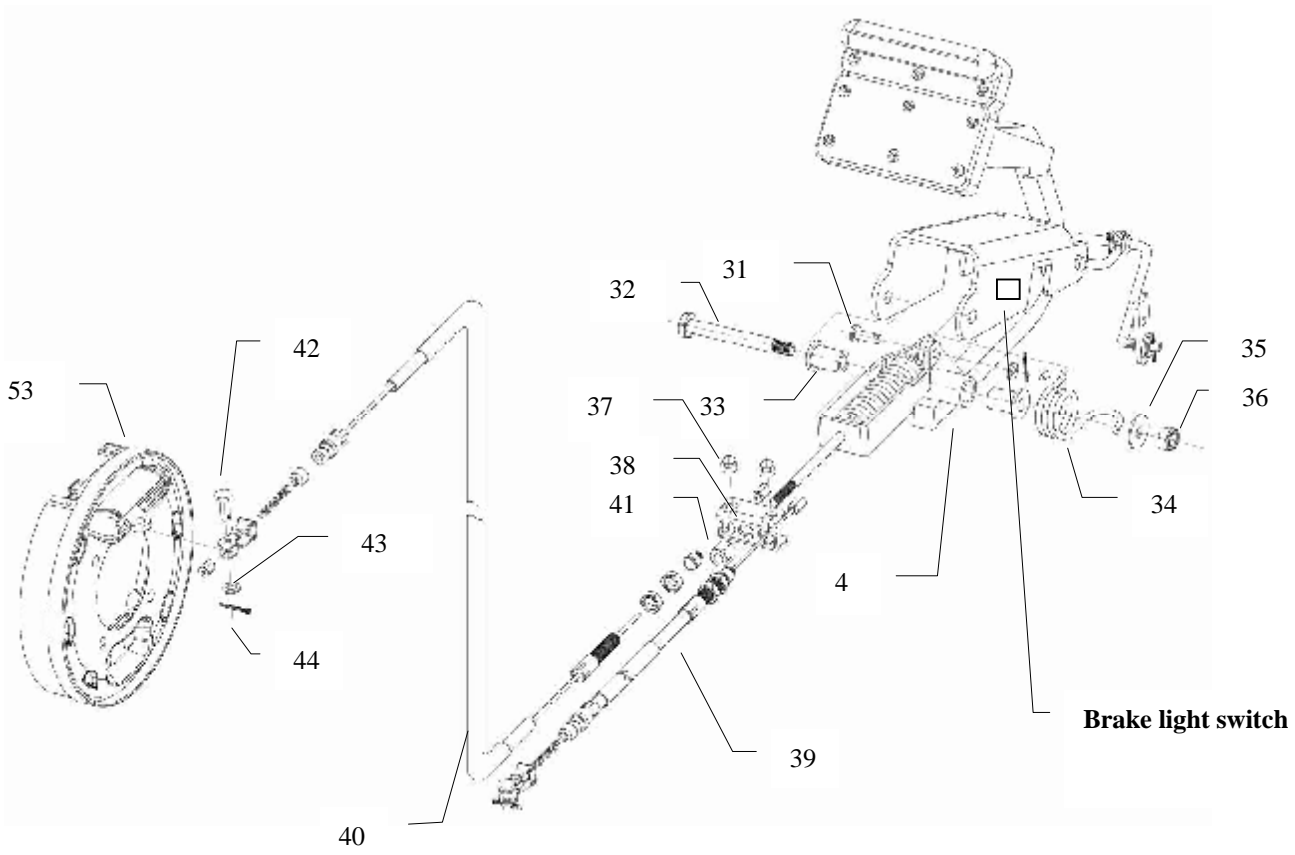
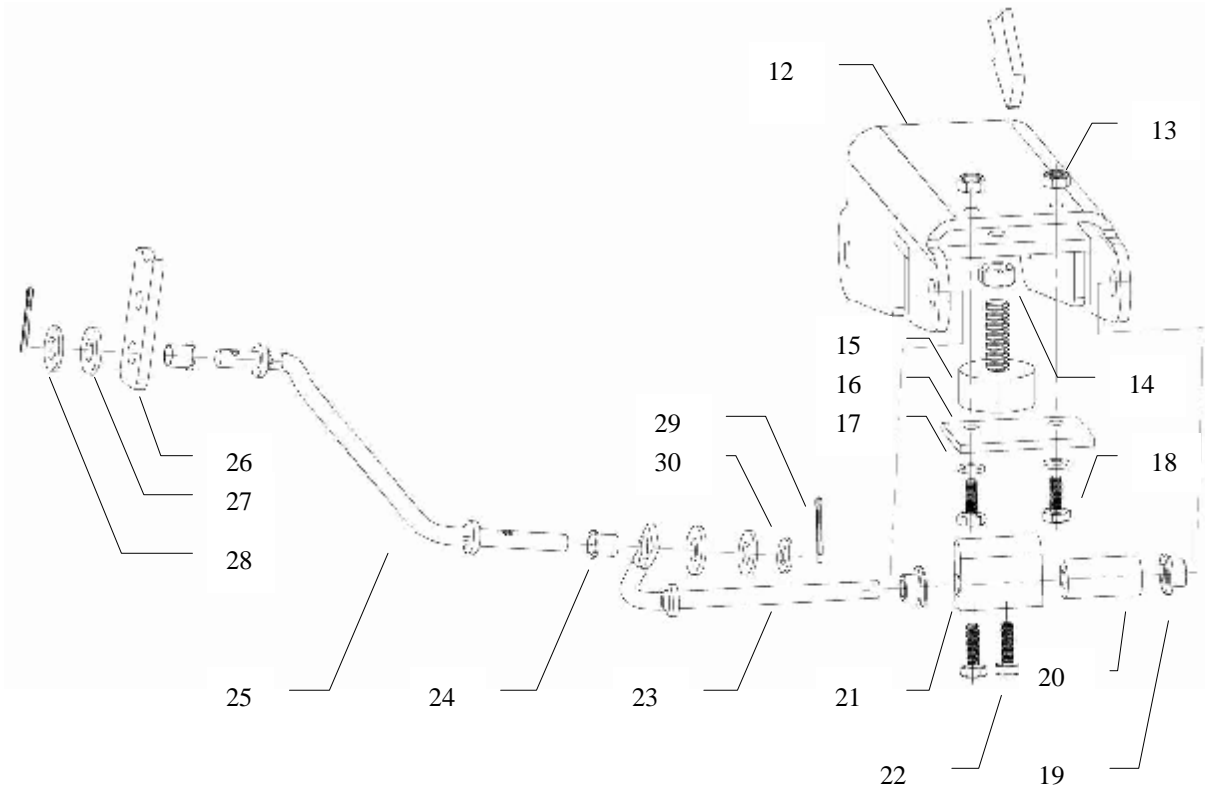

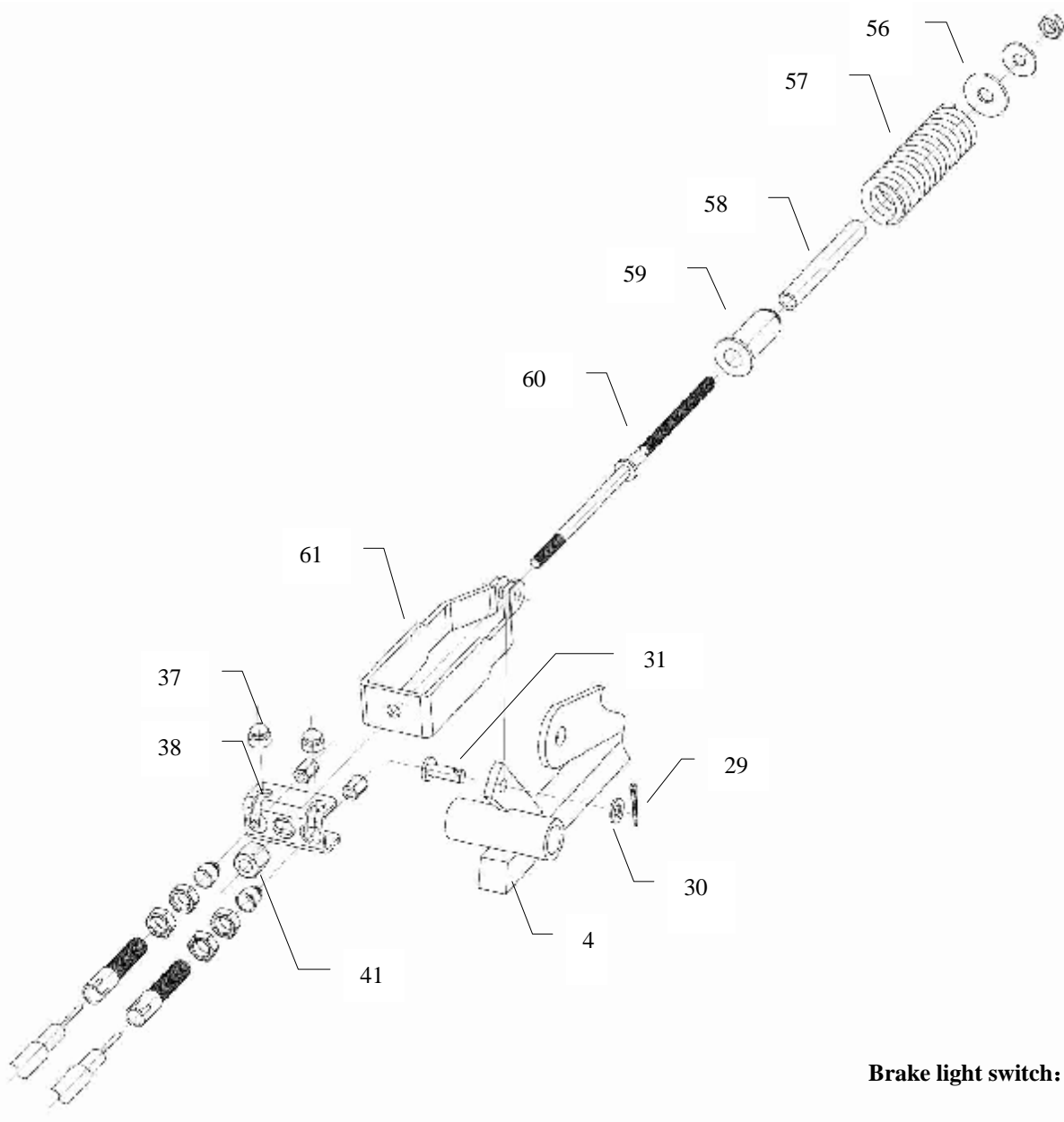

**Brake light switch:**

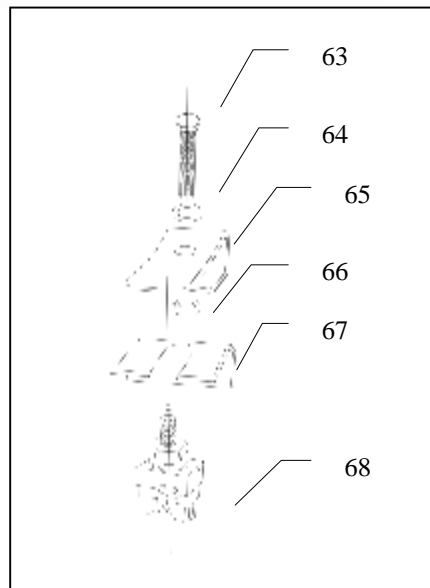

### 3-1 Braking Pedal & Bracket Assembly(制动踏板及支架总成)

Item	New Part No	Description	中文名称	Qty	Remark
1	2807141-036	Pad of parking brake pedal	制动踏板上软垫	1	
2	2807100-036	Brake pedal for parking	驻车制动踏板总成	1	
3	2803111-036	Pad of service brake pedal	制动踏板下软垫	1	
4	2803100-036	Service brake pedal	制动踏板总成	1	
5	2807136-036	Peg	销钉--驻车制动	1	
6	2807121-036	Torsion spring	驻车制动扭簧	2	
7	Q40108	Gasket M8	平垫圈 M8	1	
8	Q5000225	Split pin Φ2×25	开口销 Φ2×25	1	
9	Q2140616-304H	Cross slot bolt M6×16	十字槽盘头螺钉 M6×16	9	
10	Q40306-304H	Gasket spring M6	弹垫 M6	9	
11	Q340B06-304H	Nut M6	1 型六角螺母 M6	9	
12	2024-5101016	groove shape frame	槽形架(包含在车架上)	1	
13	Q32606-304H	Self-lock nut M6	2 型非金属嵌件六角琐 紧螺母 M6	2	
14	Q340B08-304H	nut M8	1 型六角螺母 M8	1	
15	2803123-036	Adjustable bumper block	踏板缓冲块	1	
16	2807122-036	Small pressing block	固定支架--驻车挂钩	1	
17	Q40106	Gasket M6	平垫圈 M6	2	
18	Q150B0620	Bolt M6×20	六角头螺栓 M6×20	2	
19	2807132-036	Cam axletree	释放杆轴套	2	Copper
20	2807134-036	Separation block	隔离块--释放杆凸轮	1	
21	2807133-036	Cam	释放杆凸轮	1	
22	Q150B0616	Bolt M6×16	六角头螺栓 M6×16	2	
23	2807131-036	Cam dowel	释放杆	1	
24	2024-2103007	Jacket of connecting rod	加速器连杆护套	2	Nylon
25	1007024-004	Connection rod for interlocking	加速器连杆	1	
26	1007021-004	Accelerator pedal	加速器踏板总成	1	
27	Q40108	Nylon gasket M8	平垫圈 M8	2	
28	Q40110	Gasket M10	平垫圈 M10	2	
29	Q5000225	Split pin Φ2×25	开口销 Φ2×25	1	
30	Q40108	Gasket M8	平垫圈 M8	1	
31	Q5100825	Pin M8×25	销钉 M8×25	1	
32	2803122-024	Flange bolt M10×100	制动凸肩螺栓	1	
33	2803113-036	Flange jacket	衬套--凸肩螺栓	2	
34	2803114-036	Big torsion spring	行车制动扭簧	1	
35	Q40210	Big gasket M10	大垫圈 M10	1	
36	Q32610	Self-lock nut M10	2 型非金属嵌件六角琐紧 螺母 M10	1	

37	2803122-036	Bumper head of compensator for braking	防撞头	2	
38	2803121-036	Balance bracket	平衡器	1	
39	2807310-009	Braking cable assembly	左制动软轴总成	1	EG2020ASZ
	2807310-015	Braking cable assembly	左制动软轴总成	1	EG2040ASZ
40	2807320-009	Braking cable assembly	右制动软轴总成	1	EG2020ASZ
	2807320-015	Braking cable assembly	右制动软轴总成	1	EG2040ASZ
41	2803125-036	Thickening nut M8	半圆头螺母	1	
42	Q5100825	Pin M8×25	销钉 M8×25	1	
43	Q40108	Gasket M8	平垫圈 M8	1	
44	Q5000225	Split pin Φ2×25	开口销 Φ2×25	1	
53	2802100-007	Assembly of brake	左后制动器总成	1	
54	Q340B08	Nut M8	1 型六角螺母 M8	1	
55	Q40108	Gasket M8	平垫圈 M8	1	
56	Q40208	Big gasket M8	大垫圈 M8	1	
57	2803116-036	Compression spring	大压簧	1	
58	2803118-036	Limit retainer of balancer	制动推杆轴管	1	
59	2803119-036	Protection cover	衬套--制动螺杆	1	
60	2803117-036	Pitman	制动螺杆	1	
61	2803115-036	Furcated arm	叉形臂	1	
63	Q150B0620	Hex head bolt M6x20	六角头螺栓 M6×20	1	
64	Q40106	Washer m6	平垫圈 M6	2	
65	2803124-036	Limit retainer of brake light switch	制动灯开关支架限位板	1	
66	Q340B06	Nut M6	1 型六角头螺母 M6	1	
67	5111012-023	Brake light switch bracket	制动灯开关支架	1	
68	3127010-001	Brake light switch	制动灯开关	1	

### 3-2 Rear Brake Assembly Rear (后轮制动器)

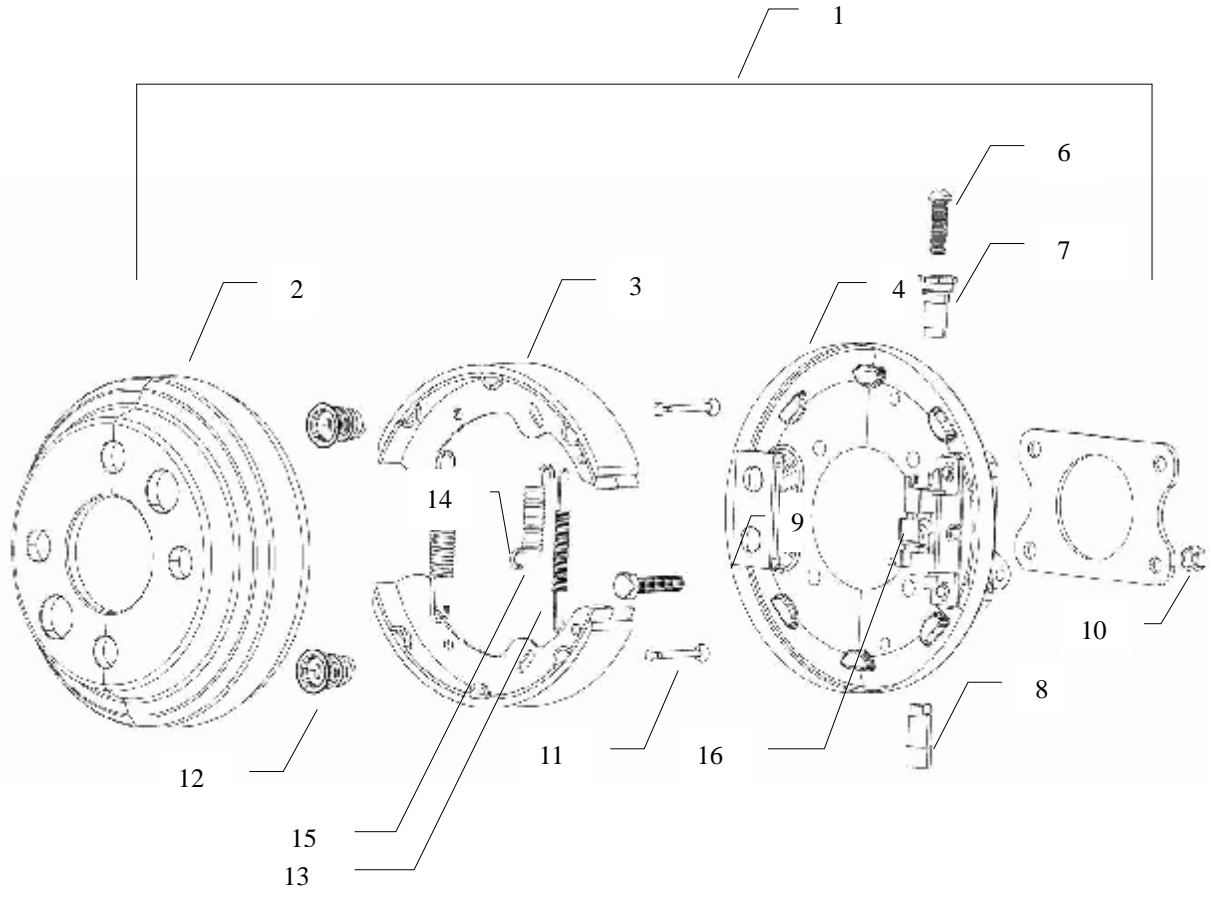



### 3-2 Rear Brake Assembly Rear (后轮制动器)

Item	New Part No	Description	中文名称	Qty	Remark
1	2802200-007	Rear Brake assembly RH(include item 3-16)	右后制动器总成(包 含 3-16)	1	2024-2802020
	2802100-007	Rear Brake assembly LH(include item 3-16)	左后制动器总成	1	2024-2802010
2	2802210-007	Rear Brake drum	后制动毂	2	2024-2804041
3	2802110-007	Brake shoe	刹车片	2	HX8060A-35072020
4		Motherboard assembly	制动蹄块底座	2	
6		Adjusting screw LH	左调整杆	1	
		Adjusting screw RH	右调整杆	1	
7		Ratchet wheel LH	左棘轮	1	
		Ratchet wheel RH	右棘轮	1	
8		Mandril head	顶杆头	2	
9	Q150B0825	Bolt M8×25	六角头螺栓 M8×25	8	
10	Q32608	Self-lock nut M8	2 型非金属嵌件六角 锁紧螺母 M8	8	
11		Bearing peg	支承销	4	
12		Spring and cuppy restrainer	限位弹簧及座	4	
13		Upside return spring	上回位弹簧	2	
14		Underside return spring	下回位弹簧	2	
15		Adjusting spring	调整簧	2	
16		Dialing clip LH	左拨片	1	
		Dialing clip RH	右拨片	1	

### 4-1 Front Axle Assembly (前桥总成)

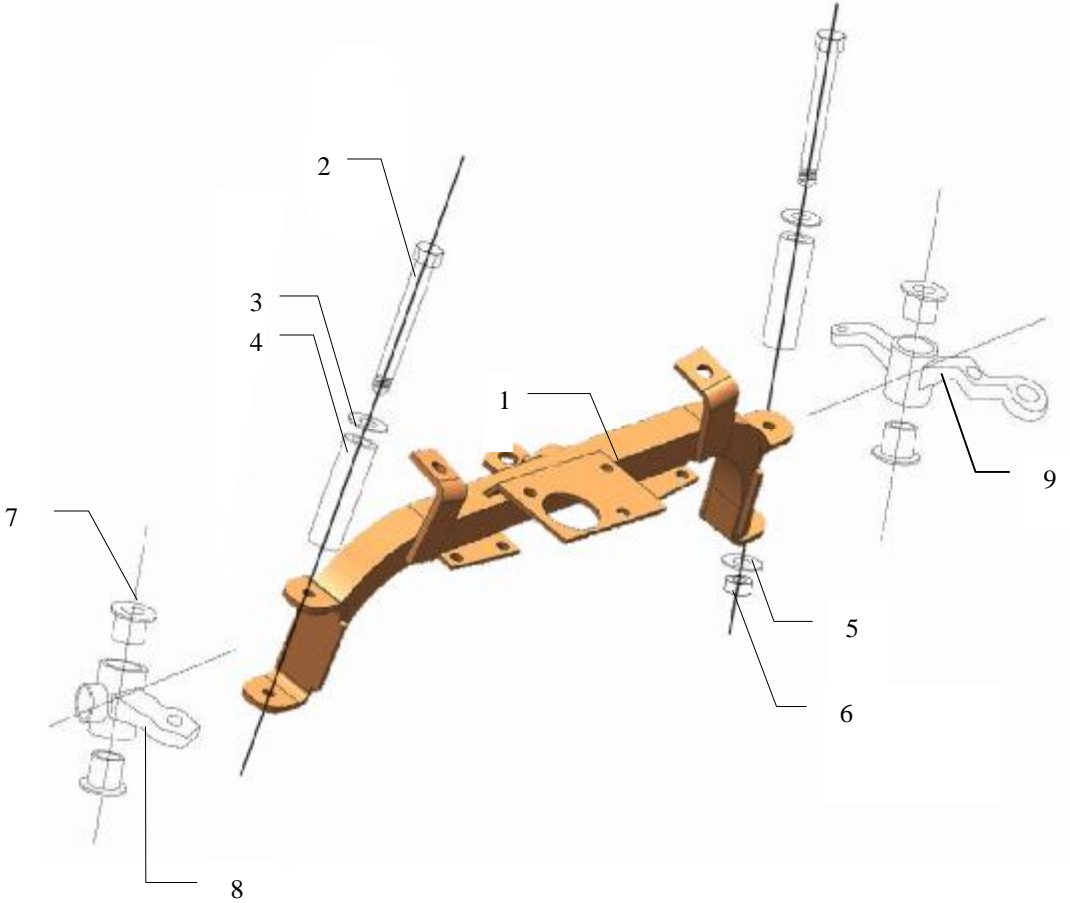

## 4-1 Front Axle Assembly (前桥总成)

Item	New Part No	Description	中文名称	Qty	Remark
1	2300000-008	Front axle assembly	前桥	1	
2	Q52110130	King pinΦ12×130	主销 Φ12×130	2	
3	Q40212	Big gasket M12	大垫圈 M12	4	
4	2302114-008	King pin pipe	主销管	2	
5	Q40112	Gasket M12	平垫 M12	2	
6	Q32612	Nut M12	2型非金属嵌件六角锁紧螺母 M12	2	
7		Oiliness copper bush	铜套	4	
8	2302100-015	Left knuckle (include item 2-7)	左转向节(包含 2-7)	1	
9	2302200-015	Right knuckle (include item 2-7)	右转向节(包含 2-7)	1	

## 4-2 Front Hub (前轮毂)

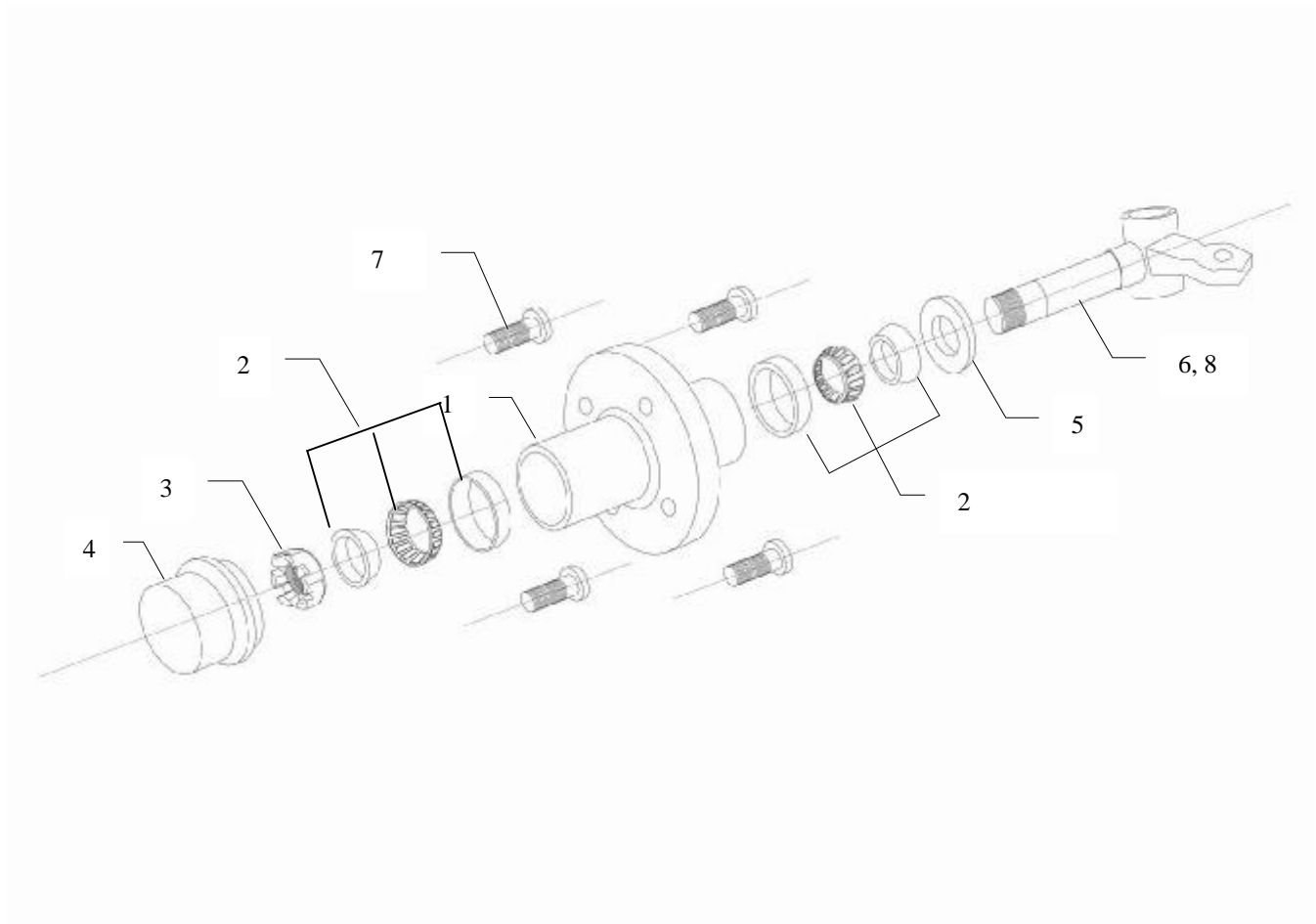

## 4-2 Front Hub (前轮毂)

Item	New Part No	Description	中文名称	Qty	Remark
1	<b>2600111-037</b>	Front hub	前轮毂	2	<b>Old P/N:</b> <b>2600111-036</b>
2	<b>44643/10</b>	Bearing assembly	轴承总成	4	
3	Q38324	Slotted nut M24	2 型六角开槽螺母— 细牙 M24	2	
4	2600114-048	Spindle cap (for steel wheel)	大轴端盖	2	
	2024-2301002A	Spindle cap (for aluminum wheel)	大轴端盖(配铝圈)	2	Chromeplate
5	2600113-036	Oil seal	油封	2	
6	<b>2302100-040</b>	Spindle assembly LH	左转向节	1	<b>Old P/N:</b> <b>2302100-008</b>

7	2600011-012	Tyre bolt M12×45	前轮螺栓	8	
8	<b>2302200-040</b>	Spindle assembly RH	右转向节	1	<b>Old P/N:</b> 2302200-008

## 5-1 Rear Axle (后桥)

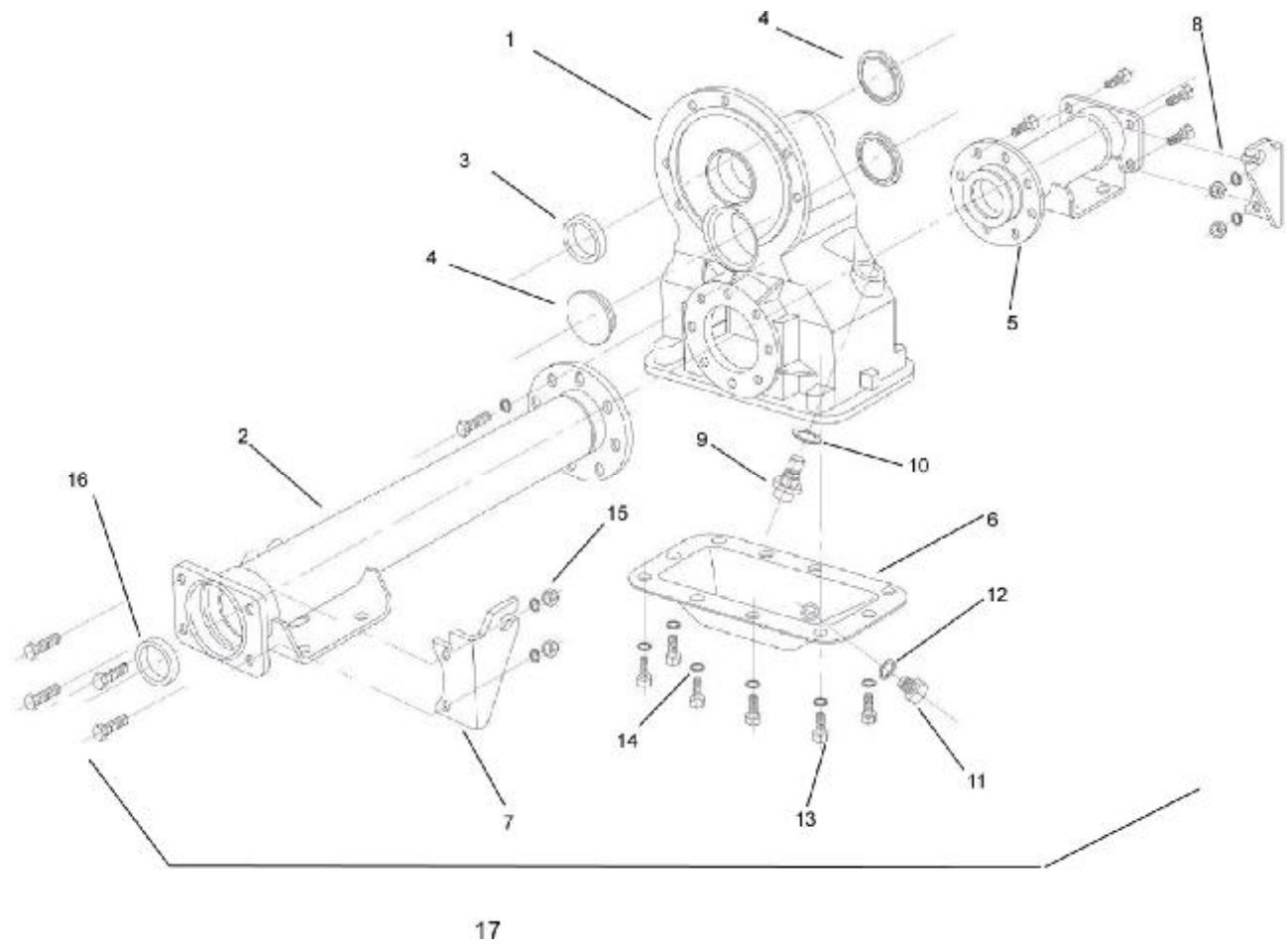

## 5-1 Rear Axle (后桥)

Item	New Part No	Description	中文名称	Qty	Remark
1	2403001-EG2024-000	Retarder case	减速度壳体(包含在后桥中)	1	
2	2401220-EG2024-00B	Right half axle sleeving	右半轴管	1	
3	<b>B32×47×8</b>	Oil seal (F) B32×47×8	油封 (F) B32×47×8	1	
4	2403006-EG2024-000	Blanking adapter	胶盖(包含在后桥中)	3	
5	2401120-EG2024-00B	Left half axle sleeving	左半轴管	1	
6	<b>2403002-EG2024-000</b>	oil pan	油底壳	1	
7	2802140-008	Right braking tube frame	左制动拉线挡板	1	
8	2802140-008	Left braking tube frame	右制动拉线挡板	1	
9	<b>2403003-EG2024-000</b>	Filler bolt	注油螺栓	1	
10	<b>2403003-EG2024-000</b>	Filler bolt gasket	注油螺栓垫	1	
11	<b>2403004-EG2024-000</b>	Drain bolt	放油螺栓	1	
12	<b>2403005-EG2024-000</b>	Drain bolt gasket	放油螺栓垫	1	
13	Q150B0825-304H	Bolt M8×25	六角头螺栓 M8×25	34	
14	Q40308-304H	Gasket spring M8	弹垫 M8	34	
15	Q32608	Self-lock nut M8	2 型非金属嵌件六角锁紧螺母 M8	8	
16	42*55*7	Oil seal	半轴油封	2	
17	2400000-019	Rear Axle 12.49:1 (include item 1-15, 5-2)	后桥 12.49:1(包含 1-15 及 5-2)	1	Include half axle

## 5-2 Half Axle Assembly (半轴总成)

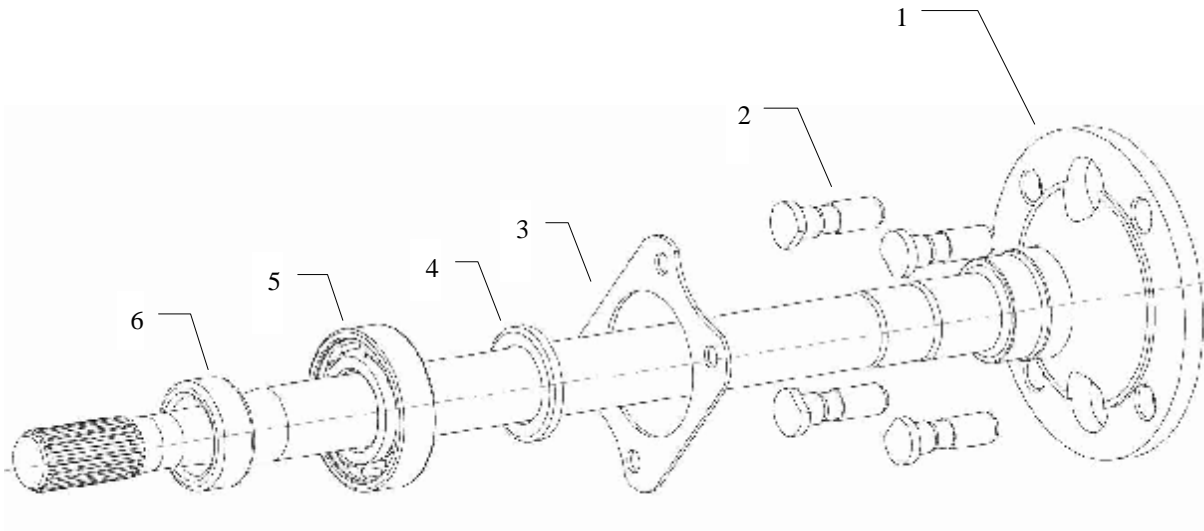

## 5-2 Half Axle Assembly (半轴总成)

Item	New Part No	Description	中文名称	Qty	Remark
1	2402100-008	Left half axle	左半轴	2	
	2402200-008	right half axle	右半轴	2	
2	2600011-011	Tyre bolt M12×45	后轮螺栓	8	
3	2401009-EG2024-000	Bearing capping	半轴轴承压盖	2	

4	9010007-06206-001	Inner shield ring	内挡圈	2	9010007-06008-000
5	9010006-06206-000	Bearing 6206-Z	轴承 6206-Z	2	
6	9010007-06206-000	Outer shield ring	外挡圈	2	

### 5-3 Retarder Assembly (主减速器总成)

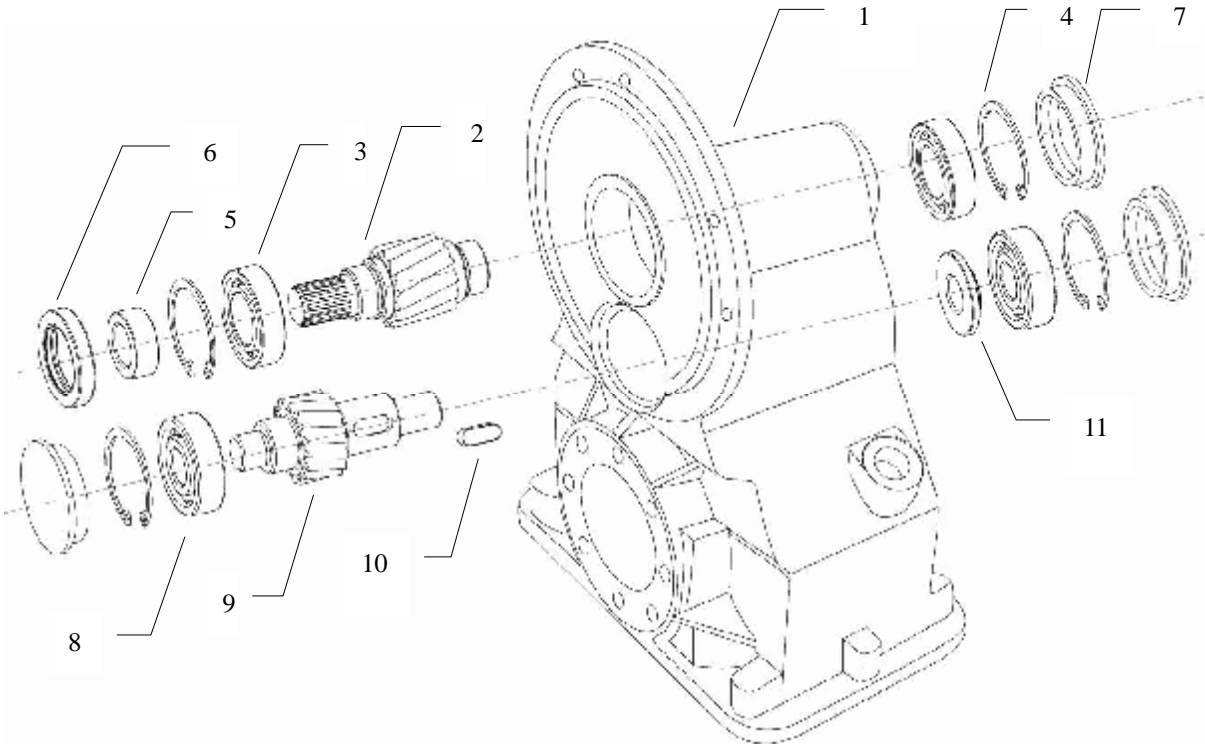

### 5-3 Retarder Assembly (主减速器总成)

Item	New Part No	Description	中文名称	Qty	Remark
1	2403001-EG2024-000	Retarder case 12.49:1	减速器壳体 12.49:1	1	
2	2403112-010	Gear shaft I	齿轮轴 I	1	
3	9010006-6005RZ-000	Bearing 6005/P6	轴承 6005/P6	2	
4	2403011-EG2024-000	Shield ring 47	挡圈 47	4	
5	9010007-6005RZ-000	Bush	衬套	1	
6	2403302-EG2024-000	Oil seal (F) B32×47×8	油封 (F) B32×47×8	1	
7	2403006-EG2024-000	Blanking adapter	胶盖	3	



8	9010006-6303RS-000	Bearing 6303/P6	轴承 6303/P6	2	
9	2403114-010	Gear shaft II	齿轮轴 II	1	
10	8×20	Bond 8×20	键 8×20	1	
11	9010007-6303RS-000	Spacer	隔套	1	

## 5-4 Differential (差速器)

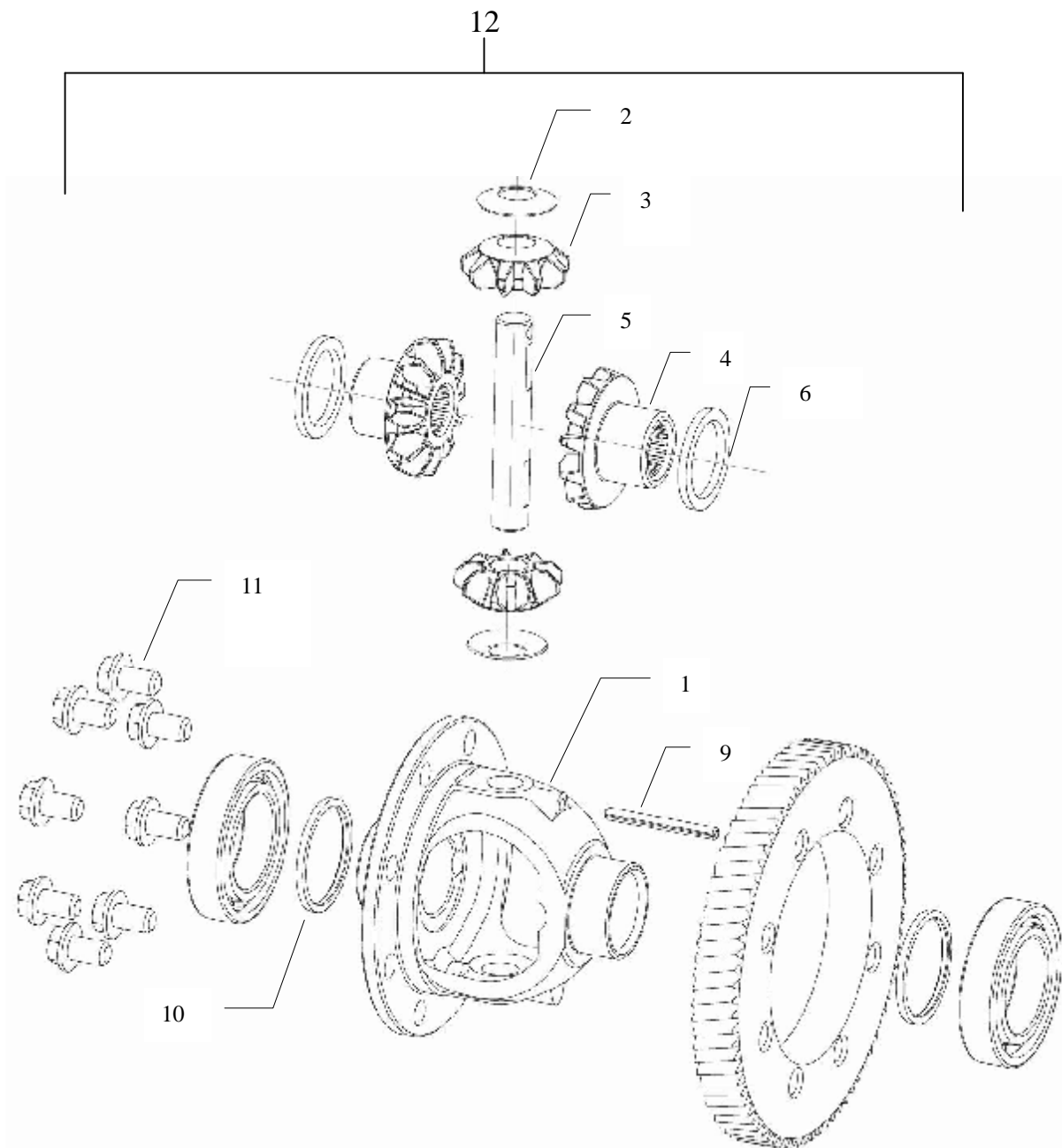

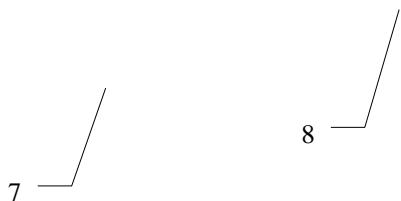

## 5-4 Differential (差速器)

Item	New Part No	Description	中文名称	Qty	Remark
1	DP-146	Differential housing	差速器壳	1	
2	DP-147	Spheroidal thrust washer	球型止推垫圈	1	
3	DP-148	Planetary gear	行星齿轮	2	
4	DP-149	Axle shaft gear	半轴齿轮	2	
5	DP-150	Planetary gear shaft	行星齿轮轴	1	
6	DP-151	Adjusting gasket	调整垫片	2	
7	DP-152	Large gear	大齿轮	1	
8	DP-153	Bearing 6008	轴承 6008	2	
9	DP-154	Pin 5×45	销 5×45	1	
10	DP-155	Washer	垫圈	2	
11	DP-156	Driving bevel gear screw	驱动锥齿轮螺钉	8	
12	2403200-008	Differential Assembly(include item1-11)	差速器总称(包括1-11)	1	

### 6-1 Front Suspension (前悬架总成)

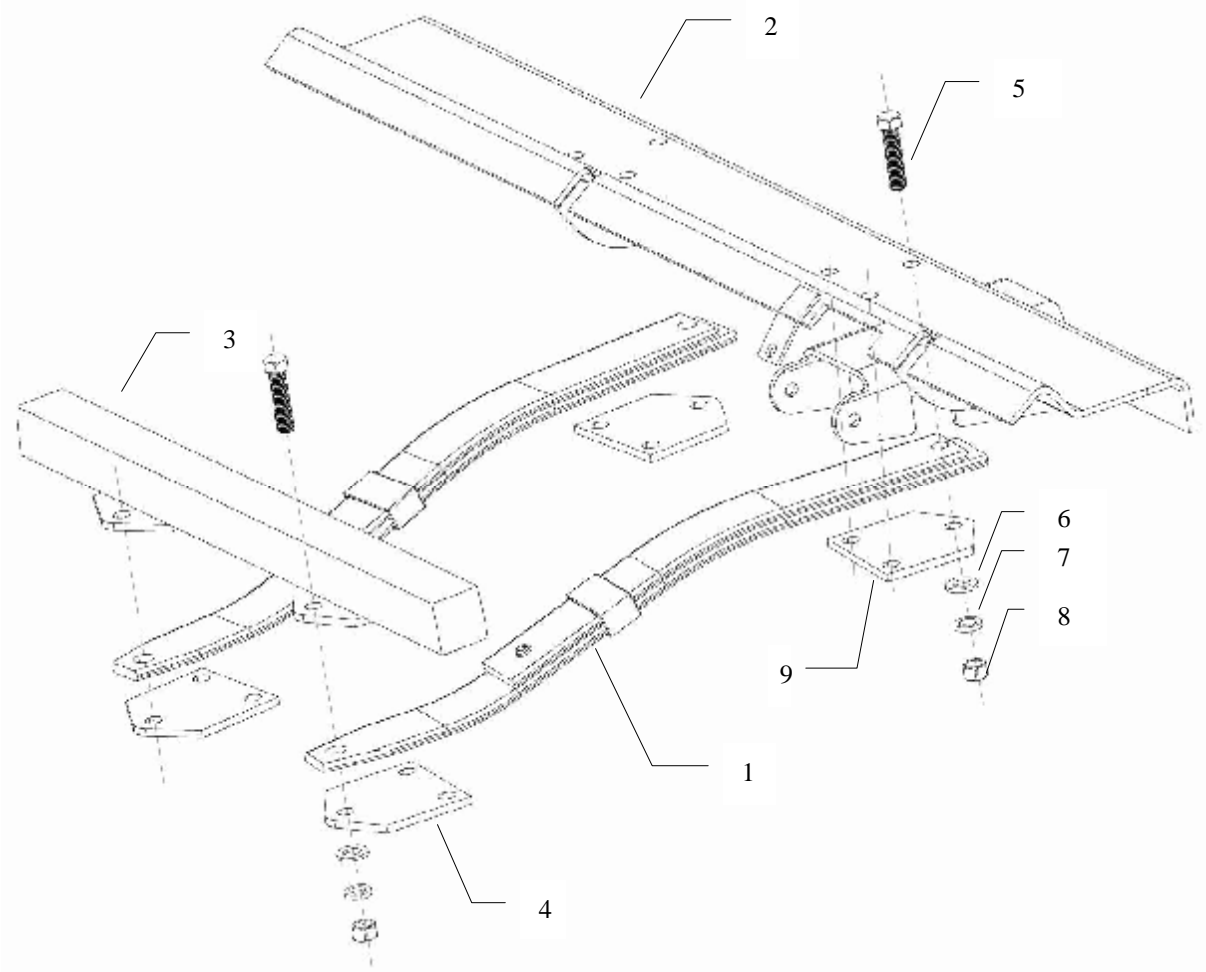

## 6-1 Front Suspension (前悬架总成)

Item	New Part No	Description	中文名称	Qty	Remark
1	2501100-009	Front leaf spring assembly	前钢板弹簧总成	2	EG2020ASZ
	2501100-010	Front leaf spring assembly	2061 前板簧	2	EG2040ASZ
2	2024-5101015	First beam of frame	第二横梁(包含在车架上)	1	
3	2300000-008	Front axle assembly	前桥总成	1	
4	2301117-004	Front leaf spring front plate	前板簧前压板	2	
5	Q150B1255	hexagon bolt M12×50	六角头螺栓 M12×45	12	
6	Q40112	Gasket M12	平垫圈 M12	12	
7	Q40312	Gasket spring M12	弹垫 M12	12	
8	Q340B12	Nut 12	1 型六角螺母 M12	12	
9	2502112-036	Front leaf spring rear plate	前板簧后压板	2	

### 6-2 Rear Suspension (后悬架总成)

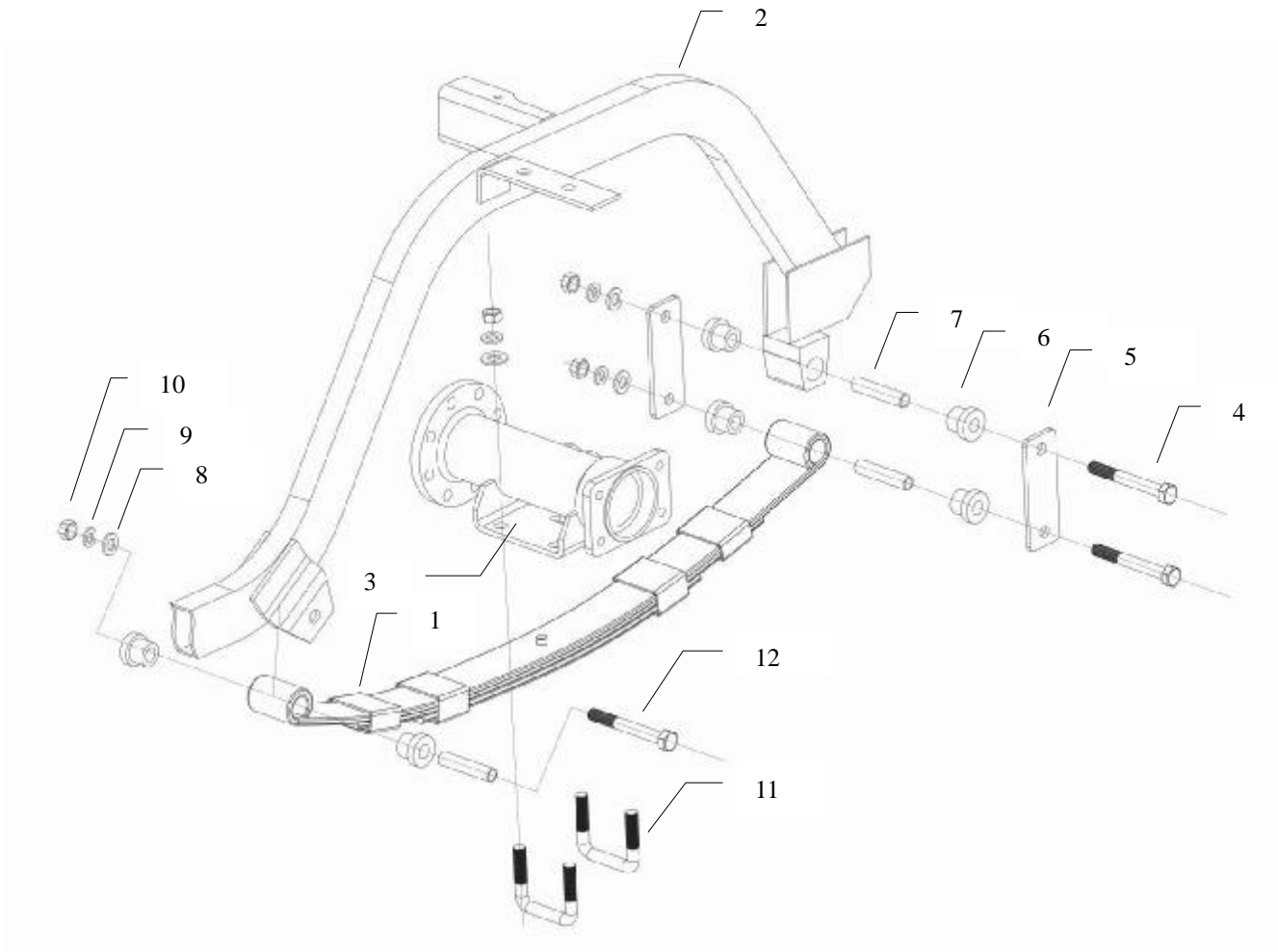

## 6-2 Rear Suspension (后悬架总成)

Item	New Part No	Description	中文名称	Qty	Remark
1	2508100-014	Rear leaf spring assembly	后钢板弹簧总成	2	
2	2024-5101010	Carling frame	纵梁(包含在车架中)	2	
3	2401120-EG2024-00B	Left half axle sleeving	左半轴管(包含在后桥中)	1	
4	Q150B1090	hexagon Bolt M10×90	六角头螺栓 M10×90	4	
5	2509015-036	Shackle	吊耳片-后板簧	4	
6	2509114-036	Flange bush	后板簧凸肩护套(厚) (4个)	12	
7	2509016-036	Separation cover	后板簧隔离套	4	
8	Q340B10	Nut M10	1型六角螺母 M10	16	
9	Q40310	Gasket spring M10	弹垫 M10	16	
10	Q40110	Gasket M10	平垫圈 M10	16	
11	2509111-036	U bolt M10	后板簧 U 形螺栓	4	
12	2509012-036	Protruding bolt on rear leaf spring	后板簧凸肩螺栓	2	
13	2509011-048	Rear leaf spring base	板簧座 2020. 2040	2	

**6-3 Front Shock Absorber (前減震器)**

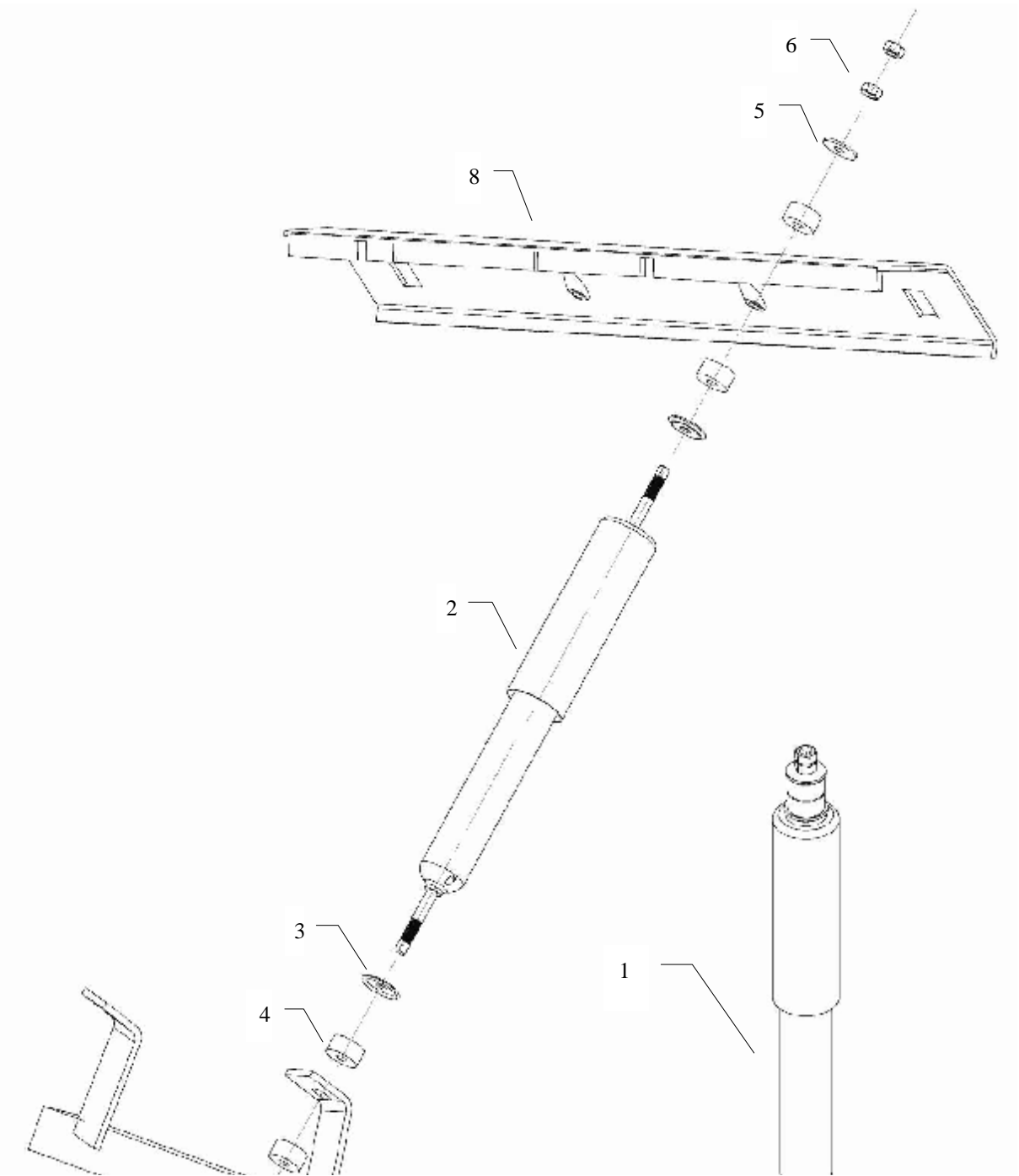

7

### 6-3 Front Shock Absorber (前减震器)

Item	New Part No	Description	中文名称	Qty	Remark
1	2504100-005	Front shock absorber assembly	前减震器总成(包含2-6)	2	
2	S30 (301) -0001	Front shock absorber assembly	防尘罩	2	
3	S30 (201) -0001	Inner retainer	垫圈	4	
4	S30 (201) -0002	Upper cushion	橡胶衬套	8	
5	S30 (201) -0001	Inner retainer	垫圈	4	
6	GB6171-86	Nut M10	螺母 M10×1	8	
7	2300000-008	Front axle assembly	前桥总成	1	
8	5101000-023	Frame	车架总成	1	



### 6-4 Rear Shock Absorber (后减震器)

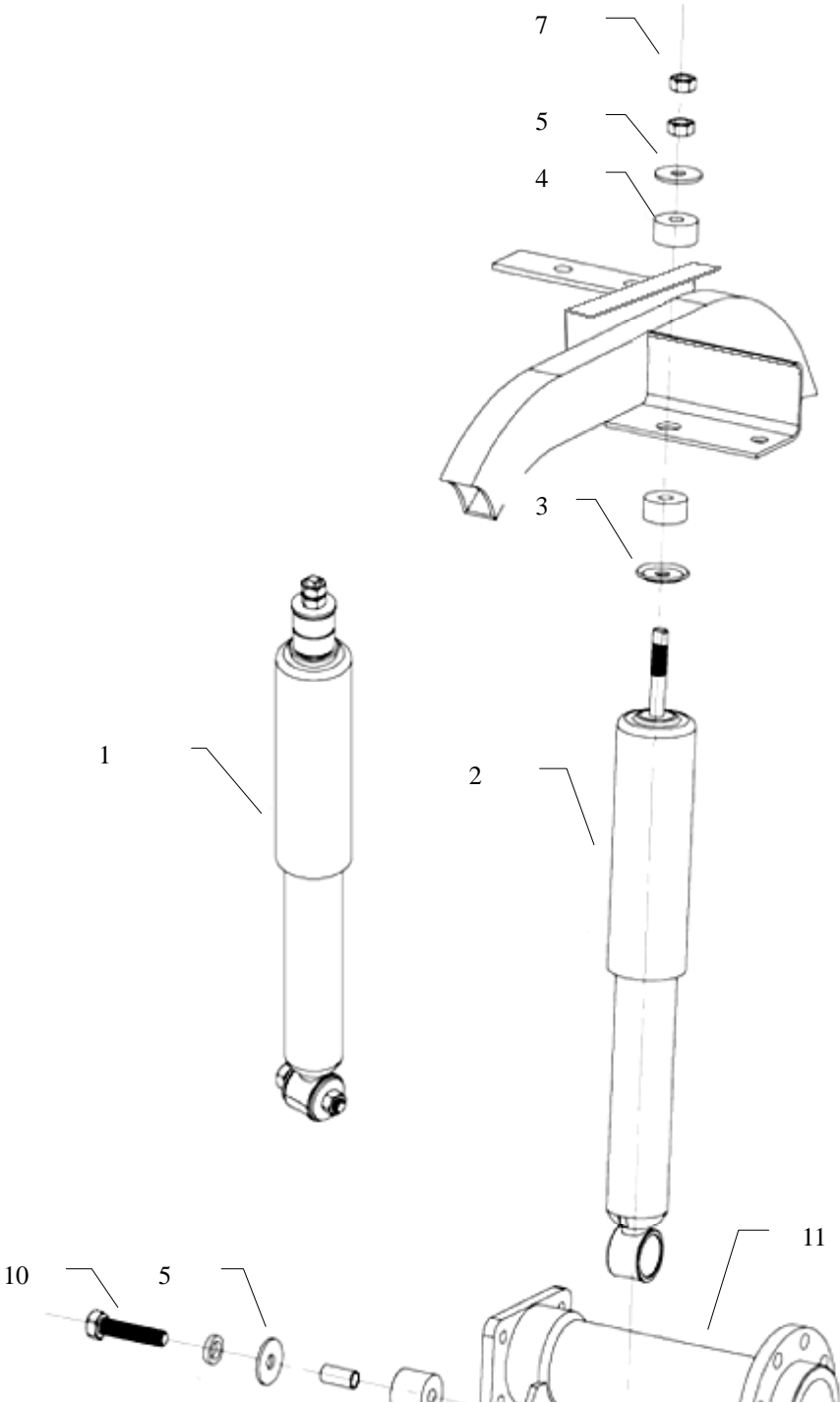

## 6-4 Rear Shock Absorber (后减震器)

Item	New Part No	Description	中文名称	Qty	Remark
1	2504100-005	Rear shock absorber assembly	后减震器总成(包含 2-7)	2	
2	S30 (301) -0001	Front shock absorber assembly	防尘罩	2	
3	S30 (201) -0001	Inner retainer (2)	垫圈	2	
4	S30 (201) -0002	Upper cushion	橡胶衬套	2	
5	S30 (201) -0001	Inner retainer (2)	垫圈	2	
7	GB6171-86	Nut M10	螺母 M10×1	2	
9	Q40310	Gasket spring M10	弹垫 M10	2	
10	Q150B1050	Bolt M10×50	六角头螺栓 M10×50	2	

# 7-1 Steering Wheel Assembly (方向盘总成)

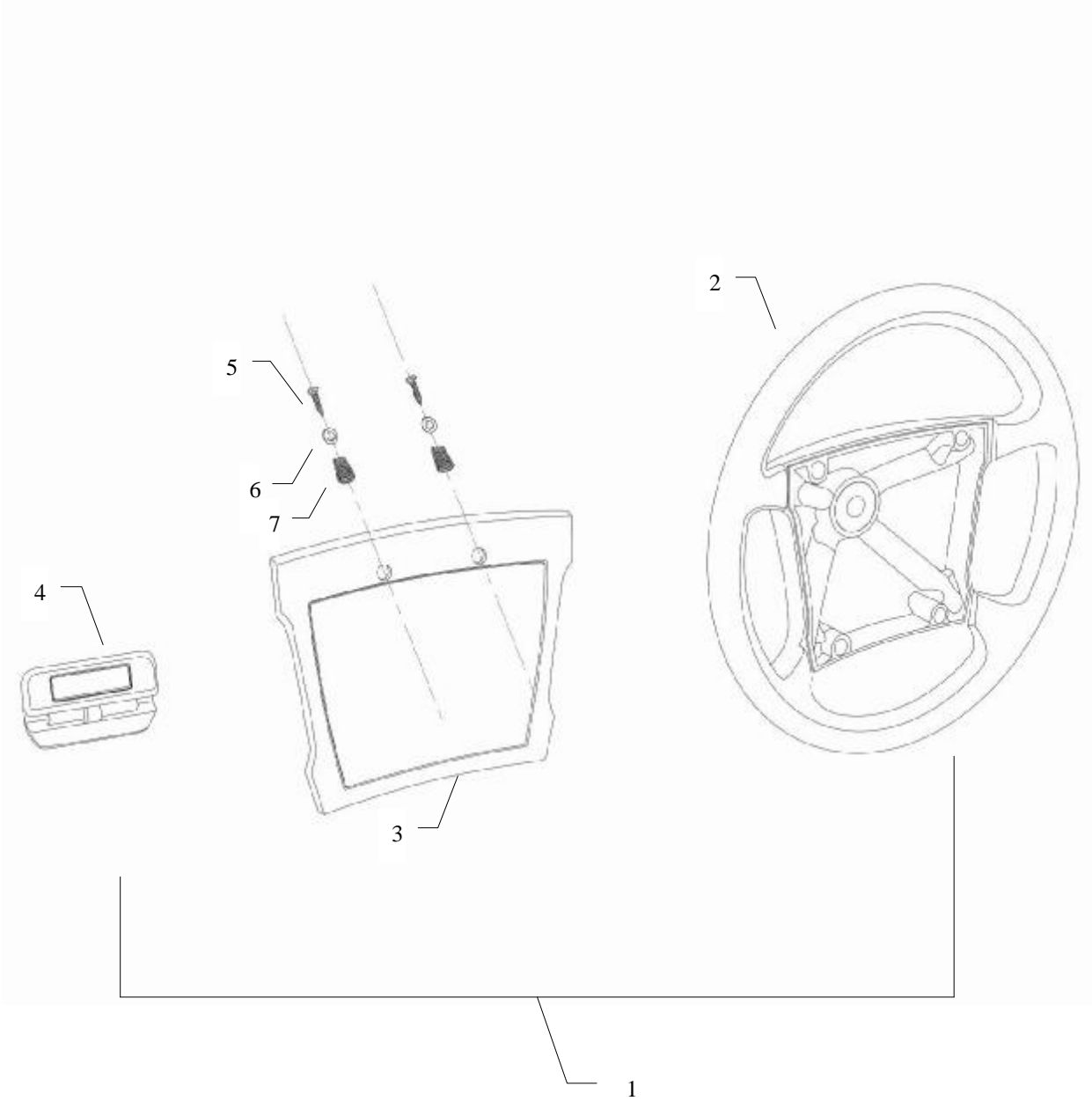

## 7-1 Steering Wheel Assembly (方向盘总成)

Item	New Part No	Description	中文名称	Qty	Remark
1	2702100-007	Steering wheel assembly (plastic)	方向盘总成(普通)	1	
	2702100-006	Steering wheel assembly (timber)	方向盘总成(桃木)	1	
3	2024-2704017	Steering wheel cover	方向盘盖	1	
4	2024-2704016	Folder	记分夹	1	
5	Q2714230	Self-tapping screw	自攻螺钉	2	
6	Q40205-304H	Gasket	平垫圈	2	
7		Spring	弹簧	2	

**7-2 Tie Rod (橫拉杆)**

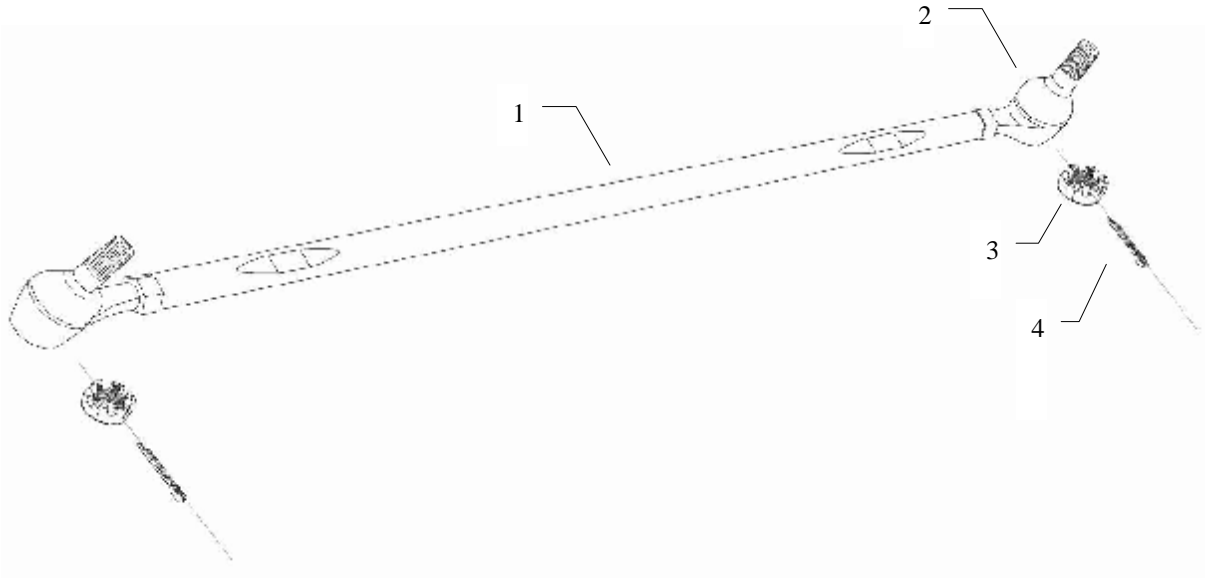

**7-2 Tie Rod (橫拉杆)**

Item	New Part No	Description	中文名称	Qty	Remark
1	2706100-048	Tie rod	转向横拉杆总成	1	
2	2706120-036	Tie rod joint	横拉杆球头	2	
3	Q381C12	Slotted nut M12	1 型六角开槽螺母—细牙 M12	2	
4	Q5000225	Split pin $\Phi 2 \times 25$	开口销 $\Phi 2 \times 25$	2	

7-3 Steering Shaft Assembly (转向轴总成)

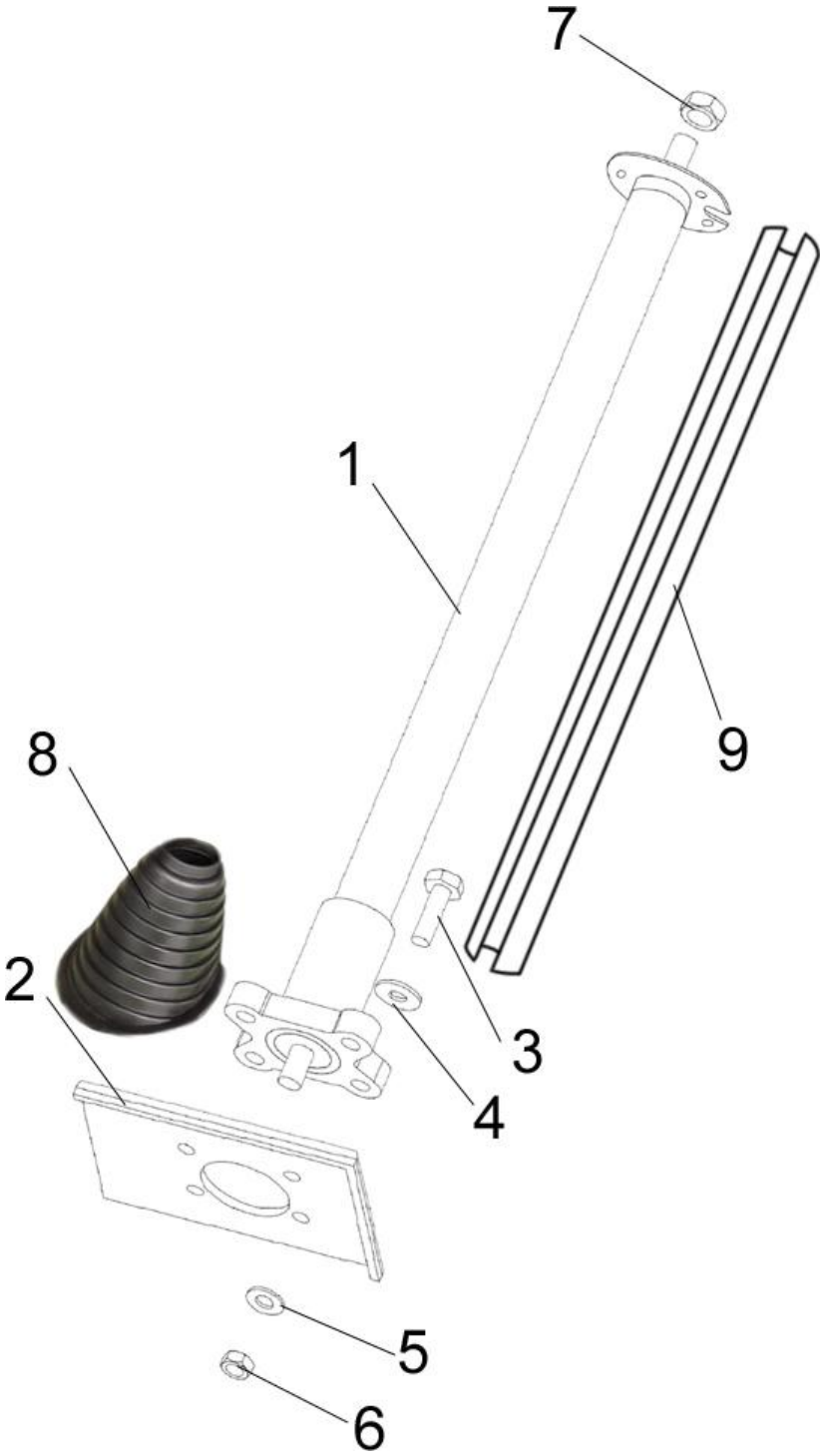

### 7-3 Steering Shaft Assembly (转向轴总成)

Item	New Part No	Description	中文名称	Qty	Remark
1	2705100-005	Steering shaft assembly	转向轴管总成	1	
2		Bracket steering shaft	转向管柱支架	1	
3	Q150B1040	Bolt M10×40	六角头螺栓 M10×40	4	
4	Q40110	Gasket M10	平垫圈 M10	4	
5	Q40310	Gasket spring M10	弹垫 M10	4	
6	Q340B10	Nut M10	1 型六角螺母 M10	4	
7	Q32624	Self-lock nut M24	2 型非金属嵌件六角锁紧螺母 M24	1	
8	2712011-036	Steering shaft bushing	方向柱护罩	1	
9	2712012-036	Steering shaft jacket	方向柱护套	1	



### 7-4 Steering Gear Assembly (转向器总成)

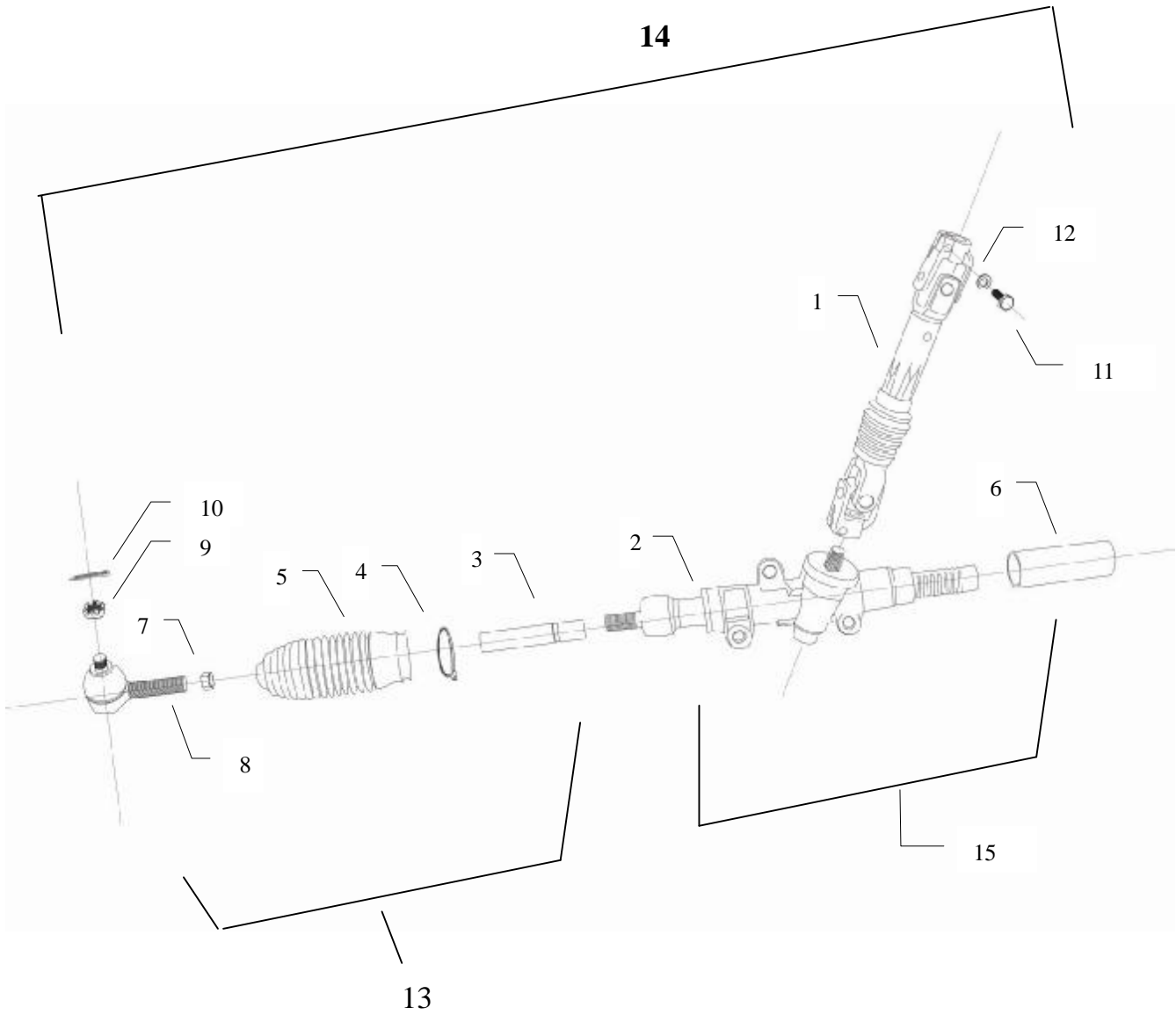

## 7-4 Steering Gear Assembly (转向器总成)

Item	New Part No	Description	中文名称	Qty	Remark
1	2704300-010	Transmission steering shaft assembly for EG2020ASZ	转向中间轴总成 (EG2020ASZ)	1	EG2020ASZ
	2704300-010	Transmission steering shaft assembly for EG2040ASZ	转向中间轴总成 (EG2040ASZ)	1	EG2040ASZ 2013年4月增长至205mm, 原编码 2704300-009, 长度185mm
2	LT3401020BM2	Steering gear housing & steering rack	转向器壳体组件	1	
3	LT3401070BM2	Rod	连杆	1	
4	5*200	Tie	扎带	1	
5	2701112-008	Dustproof cover	防尘罩	1	
6	2701111-008	Rear dustproof cap	齿条护套	1	
7	Q340B14-304H	Nut M14	1型六角螺母 M14	1	
8	2701220-008	Ball connector	球头	1	
9	Q381C12	Slotted nut M12	1型六角开槽螺母—细牙 M12	1	
10	Q5000225	Split pin $\Phi 2 \times 25$	开口销 $\Phi 2 \times 25$	1	
11	Q150B1250-304H	Hexagon Bolt M8 $\times$ 25	六角头螺栓 M8 $\times$ 25	1	
12	Q40308-304H	Gasket spring M8	弹垫 M8	1	
13	2701200-048	Puller (include item 3,8-10)	转向直拉杆总成(包含 3. 8. 9. 10)	1	
14		Steering gear assembly (include item 13&15,not including 2)	转向器总成(包含 13,15,不包含 2)	1	
15	2701100-008	Redirector Assembly (include item2, 6)	方向机总成 (包含 2, 6)	1	

### 8-1 Wheel & Tyre (车轮)

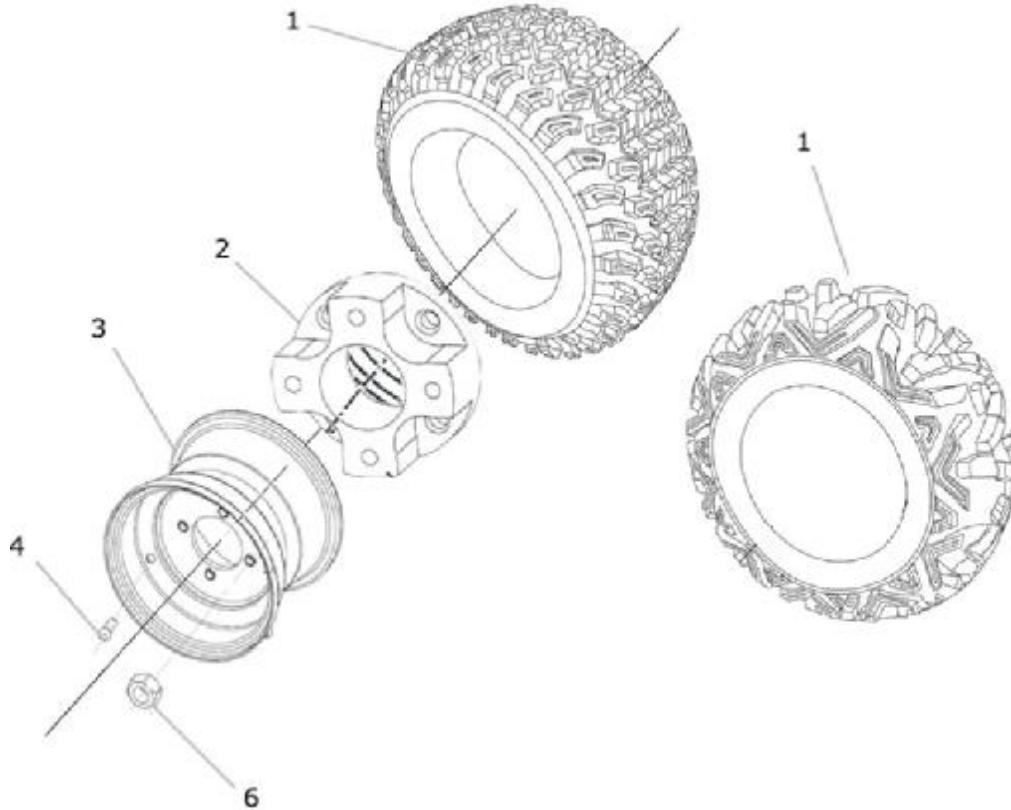

### 8-1 Wheel & Tyre (车轮)

Item	New Part No	Description	中文名称	Qty	Remark
1	2602100-016	25' Tyre	25' 轮胎	4	
	2602100-017	24' Tyre	24' 轮胎	4	
	2602100-014	22' Tyre	22' 轮胎	4	
2	2604010-048	Adapter	连接件	2	
3	2601100-020	12' Steel Rim	12*7 钢圈	4	
	1002020-008	10' Steel Rim	10*8 钢圈	4	

4	2601210-004	Tyre valve	气门嘴	4	
5					
6	2600012-013	Wheel nut	轮胎螺母	16	

## 9-1 Motor (电机)

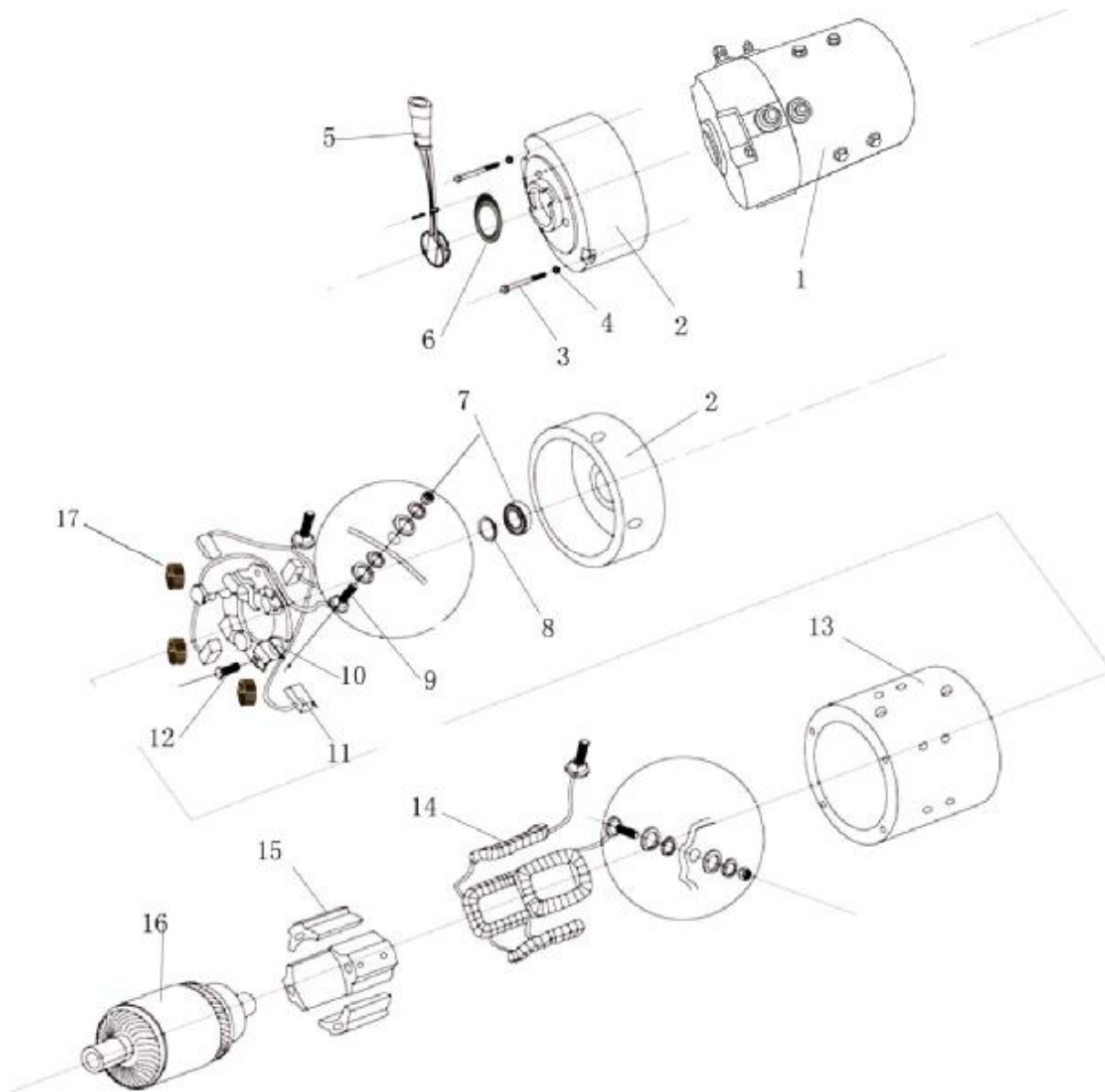

## 9-1 Motor (电机)

Item	New Part No	Description	中文名称	Qty	Remark
1	1003000-018	Motor assembly Changyin	电机总成(常银)	1	
2	MT-002	Commutator end of cover	外壳换向器末端	1	
3	MT-003	Bolt	螺栓	2	
4	MT-004	Gasket spring	弹垫	2	
5	3202020-005	Speed sensor for Chinese motor	速度传感器(常银)	1	
6	10PMS08-01	magnet coil	磁环	1	
7	MT-007	Bearing	轴承	1	
8	MT-008	Gland ring	压紧环	1	
9	MT-009	Armature binding post	电枢接线柱	2	
10	XQ-3-4/040	Brush shelf	刷架	4	
11	XQ-3.8/020	Carbon brush for Chinese motor	碳刷(国产电机)	4	
12	MT-012	Bolt	螺栓	4	
13	MT-013	Motor case	电机壳体	1	
14	MT-014	Field coil kit	励磁线圈	4	
15	MT-015	Pole core	磁极铁心	4	
16	MT-016	Armature	电枢	1	
17	XQ-3.8/030	Brush spring	压簧	1	

## 9-2 Electronic Controller Assembly (电控总成)

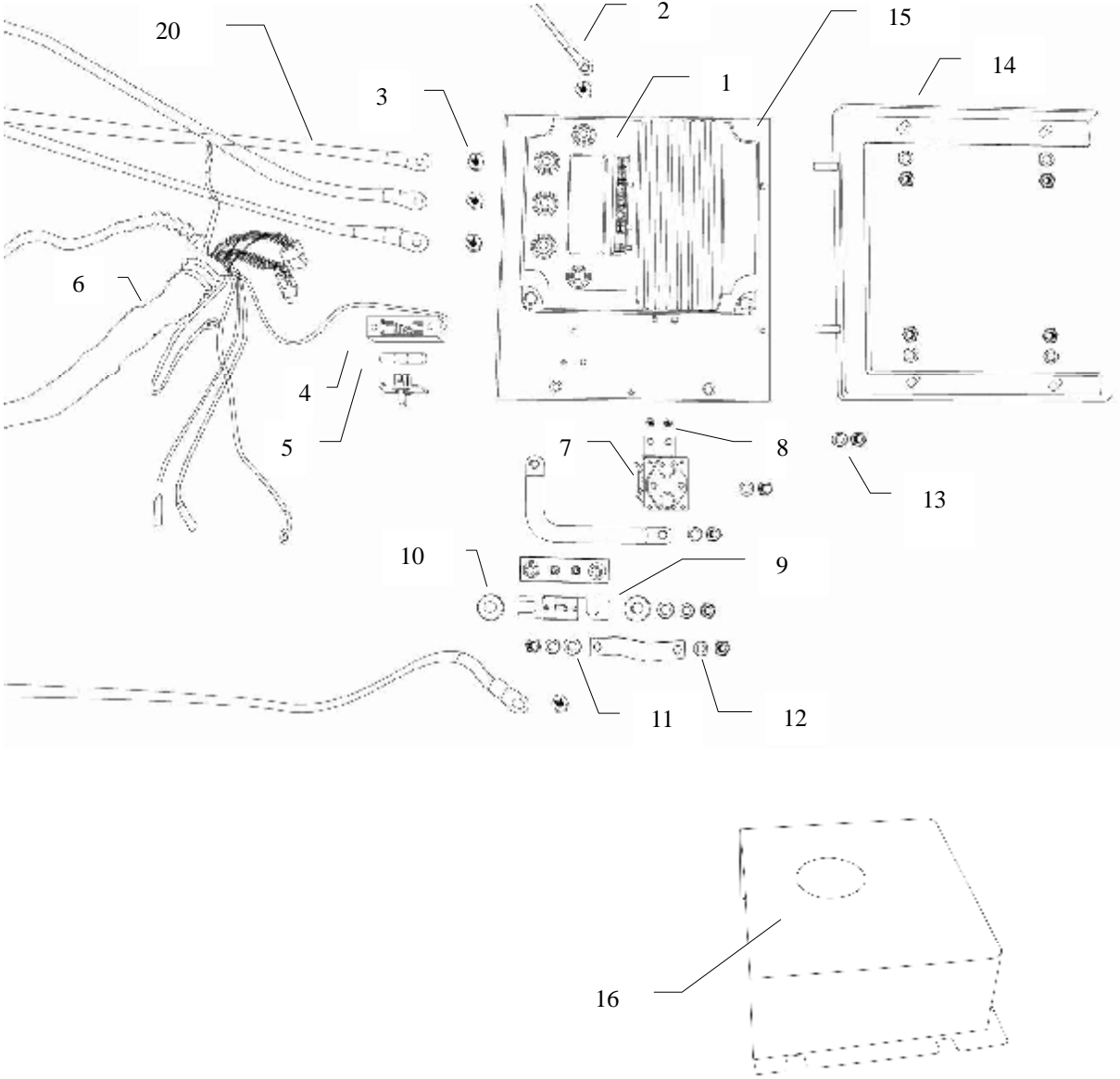

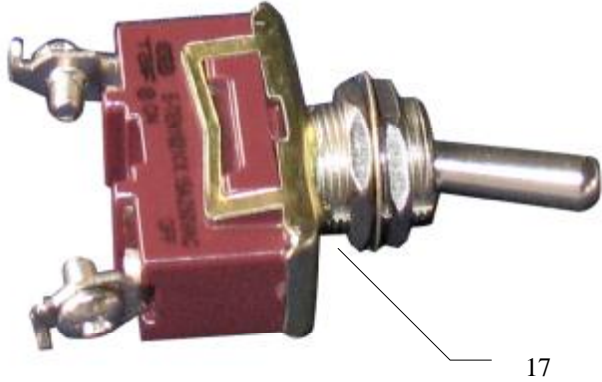

17



18

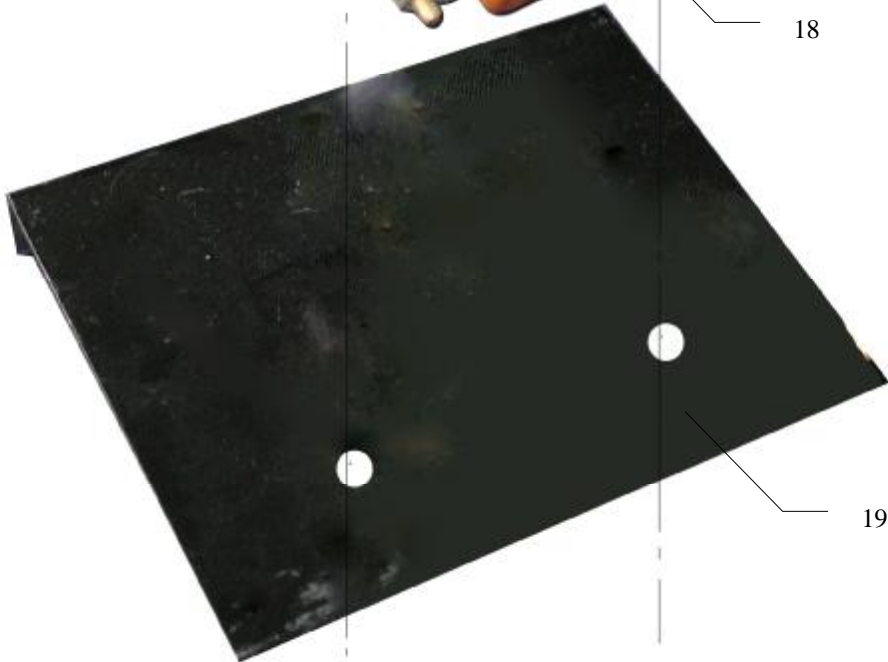

19

## 9-2 Electronic Controller Assembly (电控总成)

Item	New Part No	Description	中文名称	Qty	Remark
1	1005100-007	Controller 1268	控制器	1	
2	3313030-031	Connect wire 8 <sup>2</sup> ×600mm (red&black)	连接线 8 <sup>2</sup> ×600mm	2	
3	Q150B0820	hexagon bolt M8×20	外六角螺栓 M8×20	5	
4	F26-RT14	Attach fuse holder	附件熔断器座	1	
5	F26-R005-20A	Attach fuse	附件熔断器	1	10×38/20A
6	3302000-008	Controller harness assembly	控制器线束总成	1	EG2020ASZ
	3302000-016	Controller harness assembly	控制器线束总成		EG2040ASZ
7	SW80B-156	Main contactor	主接触器	1	
8	Q2140412	Cross slot bolt M4×12	十字槽盘头螺钉 M4×12	2	
9	F26-ANL-425A	Main fuse	主熔断器	1	425A
10	Q40208	Big gasket M8	加大平垫 M8	2	
11	Q40108	Gasket M8	平垫 M8	10	
12	Q40308	Gasket spring M8	弹垫 M8	10	
13	Q340B08	nut M8	1 型六角螺母 M8	10	
14	1005080-004	Controller bracket	控制器支架	1	1268、1244
15	1005021-008	Heat diffusion plate	散热板	1	
16	1005011-003	Controller Dustproof cover	电控防尘罩	1	
17	3032020-001	Tow/Run Switch	功能选择开关	1	1266/1268
18	3313030-001	Power wire 25 <sup>2</sup> ×440mm (Positive&Negative)	电源线 YH 25 <sup>2</sup> ×440mm(正极&负 极)	2	
19	3313030-003	Connecting wire 25 <sup>2</sup> ×1000mm (red&black)	连接线 YH 25 <sup>2</sup> ×1000mm-红黑对称	2	



### 9-4 Batteries & Connect Wire (电池及连线)

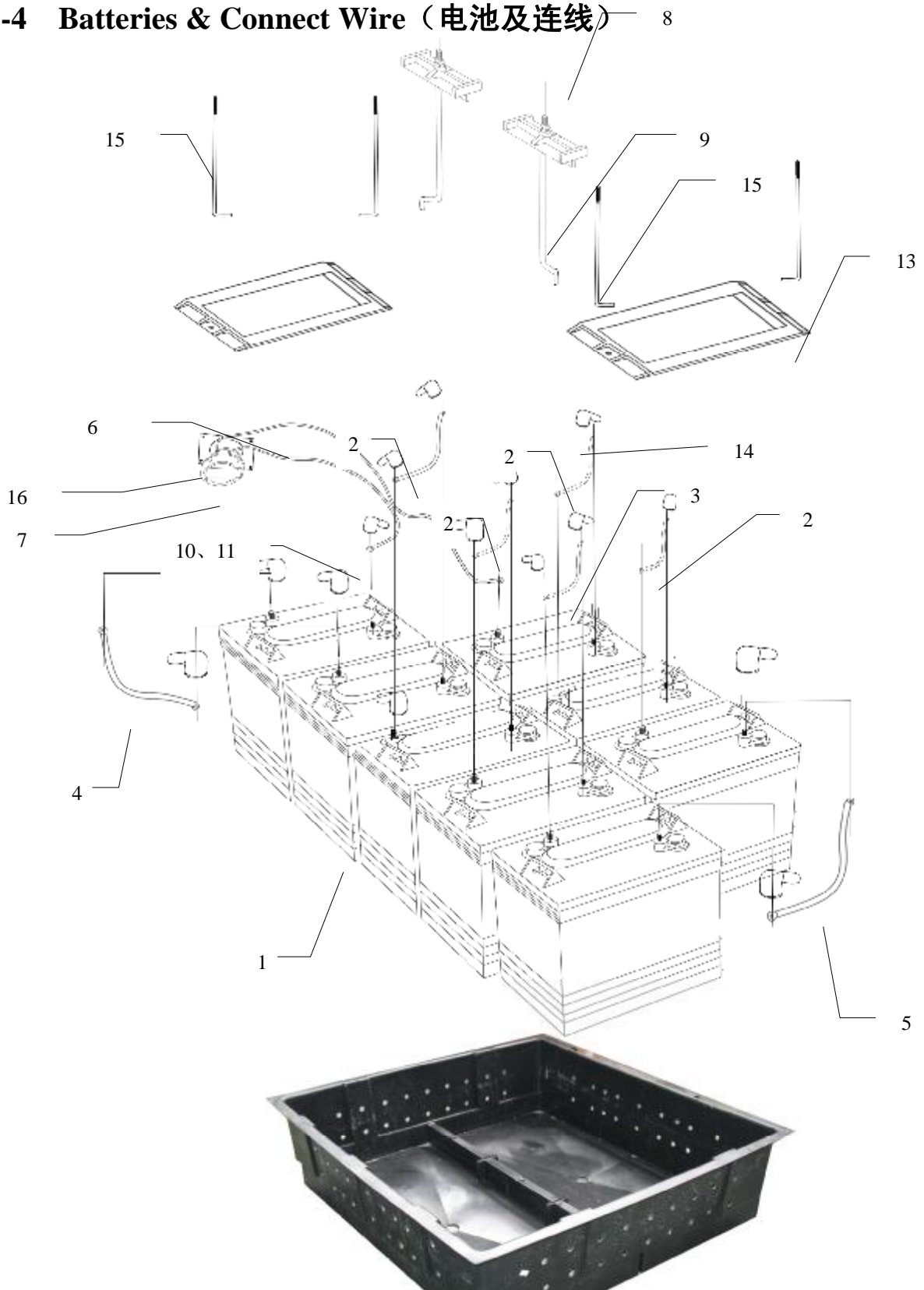

## 9-4 Batteries & Connect Wire (电池及连线)

Item	New Part No	Description	中文名称	Qty	Remark
1	T-105	Battery (T-605)	蓄电池 (T-605)	8	6V×8
2	3313010-002	Connect wire	连接线	4	25 <sup>2</sup> ×180mm
3	3313010-003	Connect wire	连接线	1	25 <sup>2</sup> ×200mm
4	3313010-005	Connect wire	连接线	1	25 <sup>2</sup> ×300mm
5	3313010-016	Connect wire	连接线	1	25 <sup>2</sup> ×380mm
6	3049120-001	Charger harness assembly	充电插座总成	1	
7	3049120-019	Charger receptacle	充电插座	1	
8	1101012-002	Battery impact block	蓄电池压块	2	
9	1101011-005	Battery dead lever	蓄电池固定杆	2	
10	FB01009	British system nut	英制螺母	12	英制 5/16-8
11	Q40308-304	Gasket spring M8	弹垫 M8	12	
12	1101013-002	Battery box	电池盒	1	
13	1101012-003	Battery impact block	单电池压块	2	
14	1101014-002	Battery dead lever	电池护套	16	
15	1101011-004	Battery dead lever	单电池固定杆	4	
16	2024-3022002	Press plate for receptacle	充电插座压板		

**10-1 Instrument Panel, Start Key (仪表面板、启动开关)**

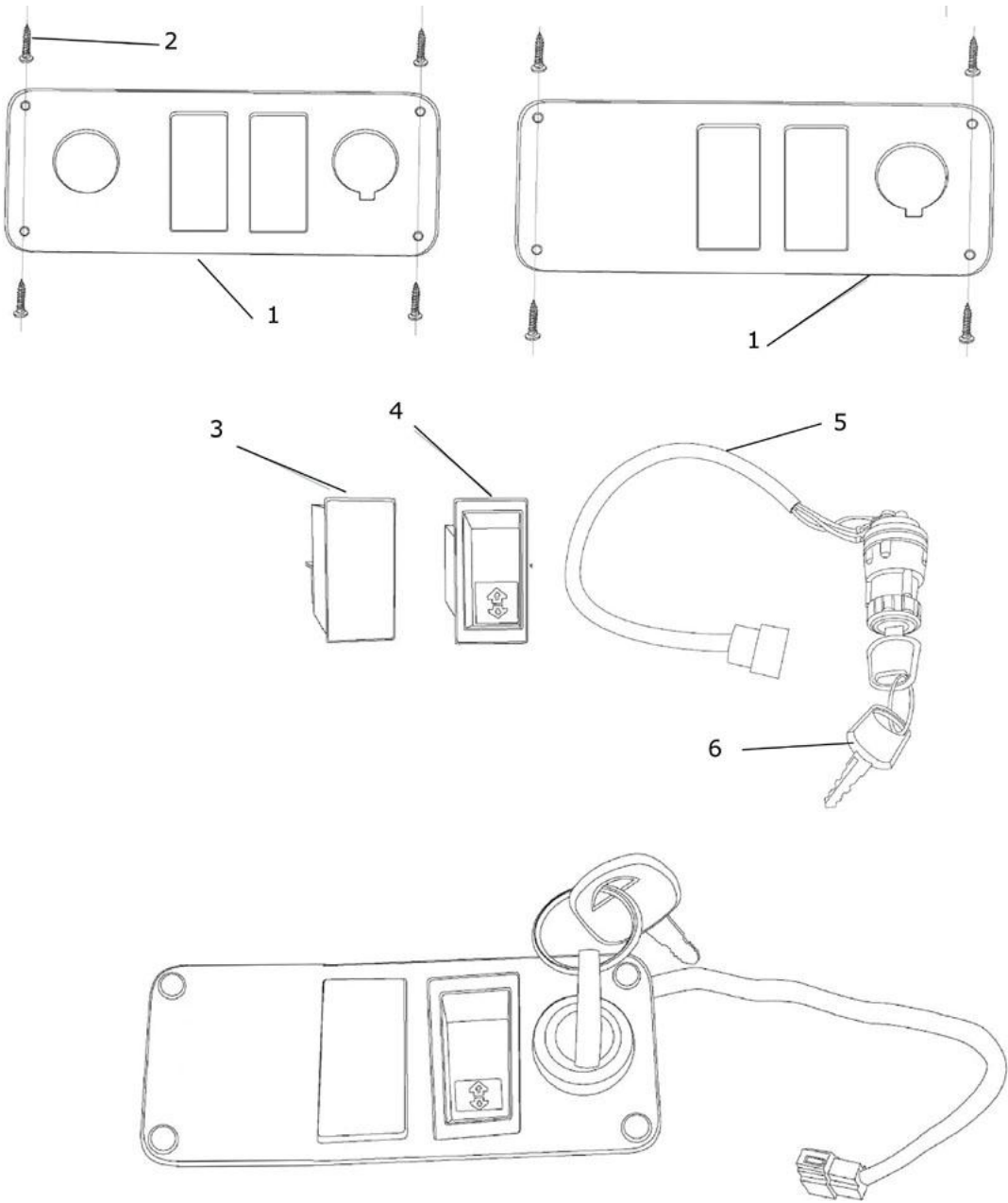

## 10-1 Instrument Panel, Start Key (仪表面板、启动开关)

Item	New Part No	Description	中文名称	Qty	Remark
1	3212051-001	Panel (One round hole)	仪表面板(单孔)	1	单孔(单孔)
	3212051-002	Panel (two round hole)	仪表面板(双孔)	1	双孔(双孔)
2	Q2730416-304H	Self-tapping screw M4×16	黑镍十字槽大半圆头 自攻螺钉 M4×16	4	
3	3217010-001	Battery power meter 36V	36V 电量表	1	
	3217010-002	Battery power meter 48V	48V 电量表		
4	3032010-001	F/R switch	进退开关	1	
5	JK423LM-1	Start key (include item 6)	点火锁	1	
	JK423LM-3	Universal Start key (include item 6)	通用点火锁	1	
6	JK423L-001	Key	钥匙	2	

**10-2 Combination switch, Loud speaker, Backup buzzer, Electronic flasher, Auxiliary relay (组合开关、喇叭、倒车蜂鸣器、电子闪光器、辅助继电器)**

)

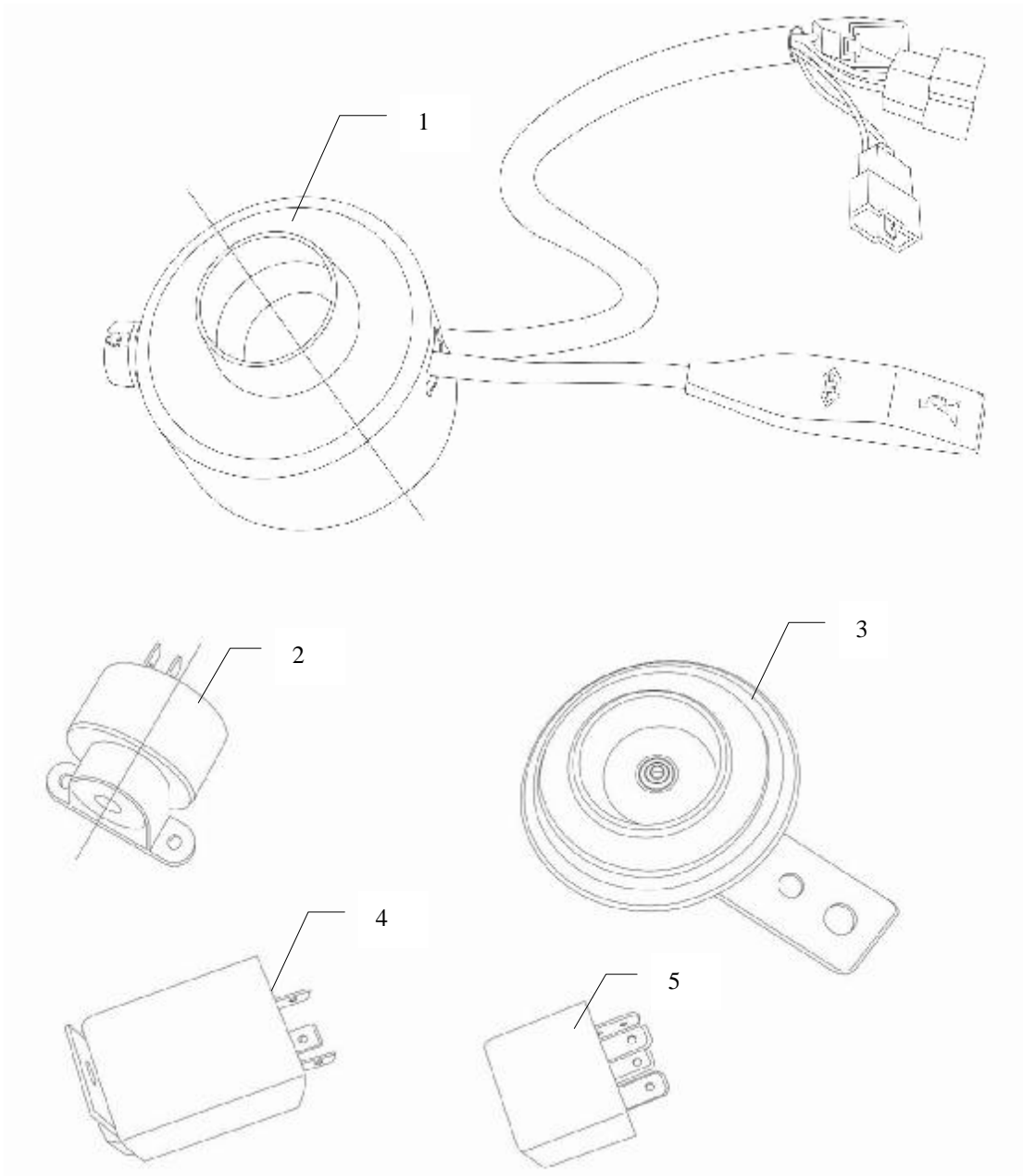

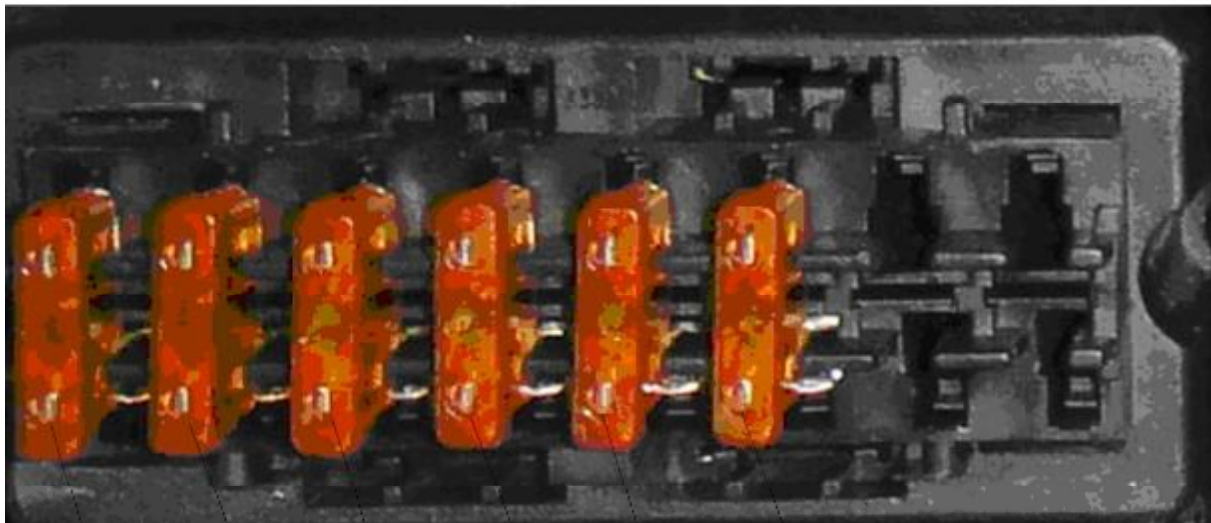
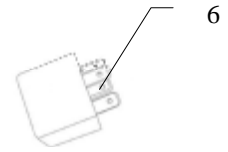

**10-2 Combination switch, Loud speaker, Backup buzzer, Electronic flasher, Auxiliary relay (组合开关、喇叭、倒车蜂鸣器、电子闪光器、辅助继电器)**

Item	New Part No	Description	中文名称	Qty	Remark
1	3024100-005	Combination switch	组合开关	1	
2	3004010-001	Electric horn	电喇叭	1	12V
3	3211010-003	Reverse buzzer	倒车蜂鸣器	1	
4	3129010-002	Electronic flasher	电子闪光器	1	
5	3040010-001	Auxiliary relay	辅助继电器	1	36V
	3040010-002	Auxiliary relay	辅助继电器	1	48V
6	3040010-003	Time-lapse relay	延迟继电器	1	
7	BX2081	Fuse box	组合开关	1	
8	B-5A	5A fuse	5A 保险	6	

### 10-3 Charger (充电器)

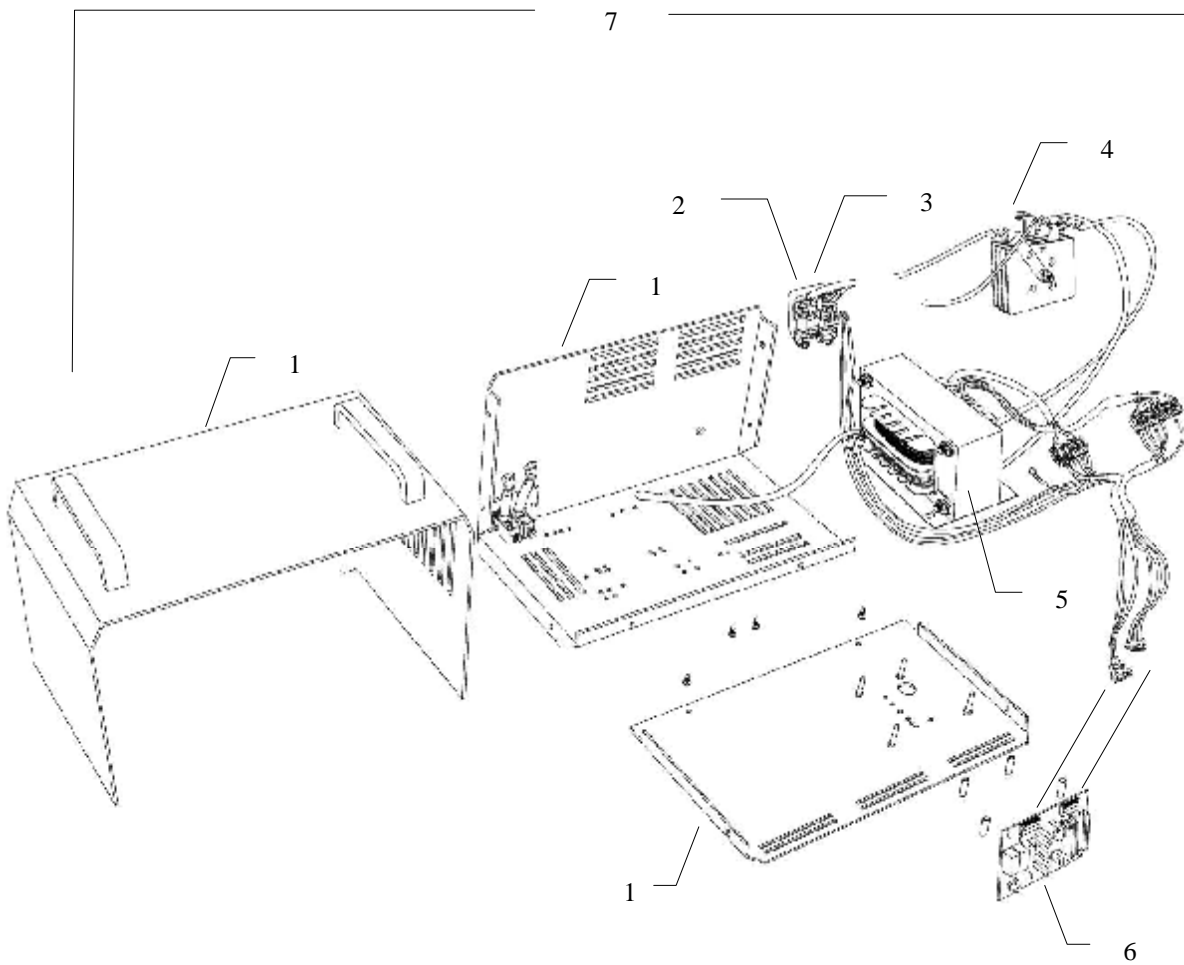

### 10-3 Charger (充电器)

Item	Part No	Description	中文名称	Qty	Remark
1	603172	Charger case	充电器箱体	1	
2	70423	Shunt	采样电阻	1	



3	3606	Output fuse	输出保险	1	
4	7458	Rectifier	整流器	1	
5	663511	Transformer	变压器	1	48V25A
6	ST-80100033	Circuit control board	电路控制板	1	
7	ST48V/25A-110V-A	Charger 48V (110V input)	充电机总成	1	
	ST48V/25A-230V-A	Charger 48V (230V input)	充电机总成	1	

## 10-4 Light System (灯光系统)

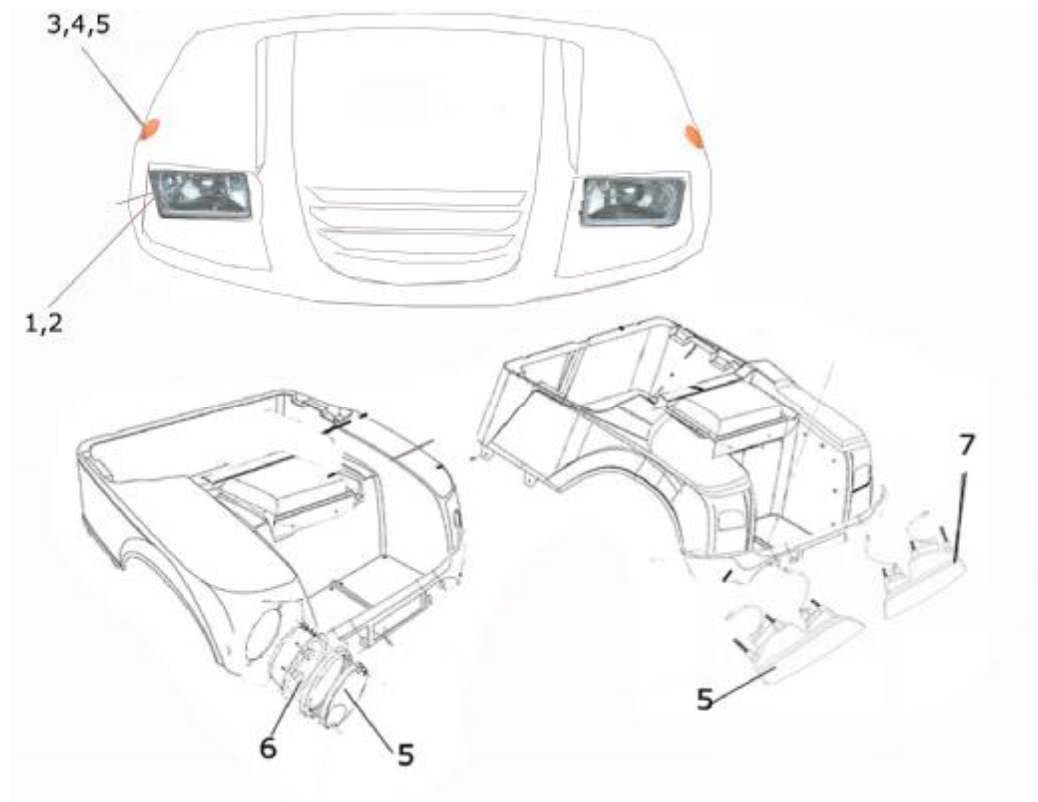

## 10-4 Light System (灯光系统)

Item	New Part No	Description	中文名称	Qty	Remark
1	3101100-008	Headlight	前大灯	2	
2	H4-55/60	Headlight bulb	大灯灯泡	2	
	3109100-005		前转向灯		
3		Turn light bulb	前转向灯灯泡	4	
	3312010-001		转向灯连接线		
4	3308000-002	Accessory wire harness	附加线束	1	EG2020ASZ
	3308000-006	Accessory wire harness	附加线束	1	EG2040ASZ

5	3126100-003	Rear assembled light, LH	左组合尾灯	1	
	3126100-005	2024 taillight	2024 尾灯	2	
6	3126130-003	Brake bulb	制动灯灯泡	2	
7	3126200-003	Rear assembled light, RH	右组合尾灯	1	
8	Q40105-304H	Washer ring M5	平垫圈 M5	12	
9	Q40305-304H	Gasket M5	弹垫 M5	12	
10	Q340B05-304H	Nut M5	1 型六角螺母 M5	12	

## 11-1 Accelerator Assembly (加速器总成)

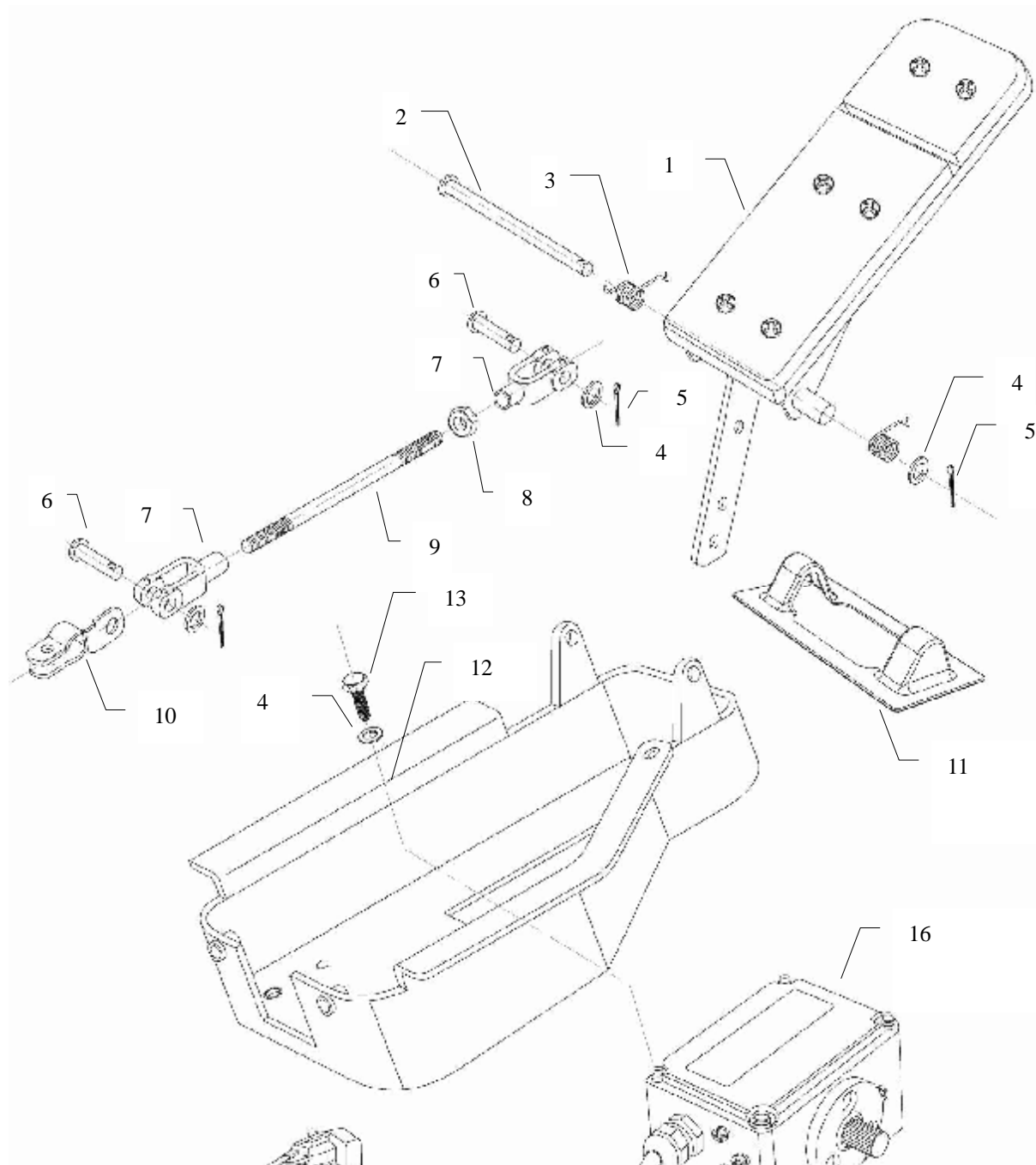

14  
15

## 11-1 Accelerator Assembly (加速器总成)

Item	New Part No	Description	中文名称	C	Remark
1	1007021-004	Accelerator Pedal Assembly	加速器踏板总成	1	
2	1007028-004	Pedal shaft peg M8×100	销钉	1	
3	2803127-036	Torsion spring	加速扭簧	2	Eudipleural
4	Q40108	Gasket M8	平垫 M8	5	
5	Q5000225	Split pin Φ2×25	开口销 Φ2×25	3	
6	Q5100825	Pin M8×25	销钉 M8×25	2	
7	1007026-004	Front/rear fork	前叉	2	
8	Q305	Nut M8 left-handed	左旋螺母 M8	1	
9	1007027-004	Putter	推杆	1	
10	1007025-004	Transmission fork	拨叉	1	
11	1007023-004	Decorative cover of pedal shaft	加速器板盖--加速踏板盖	1	
12	5111020-023	Accelerator box	加速器盒	1	
13	Q150B0820	hexagon bolt M8×20	六角头螺栓 M8×20	2	
14	Q40308	Gasket spring M8	弹垫 M8	2	
15	Q340B08	nut M8	1 型六角螺母 M8	2	
16	1007100-004	Accelerator	加速器	1	

**11-2 Accelerator Pedal Assembly (加速踏板总成)**

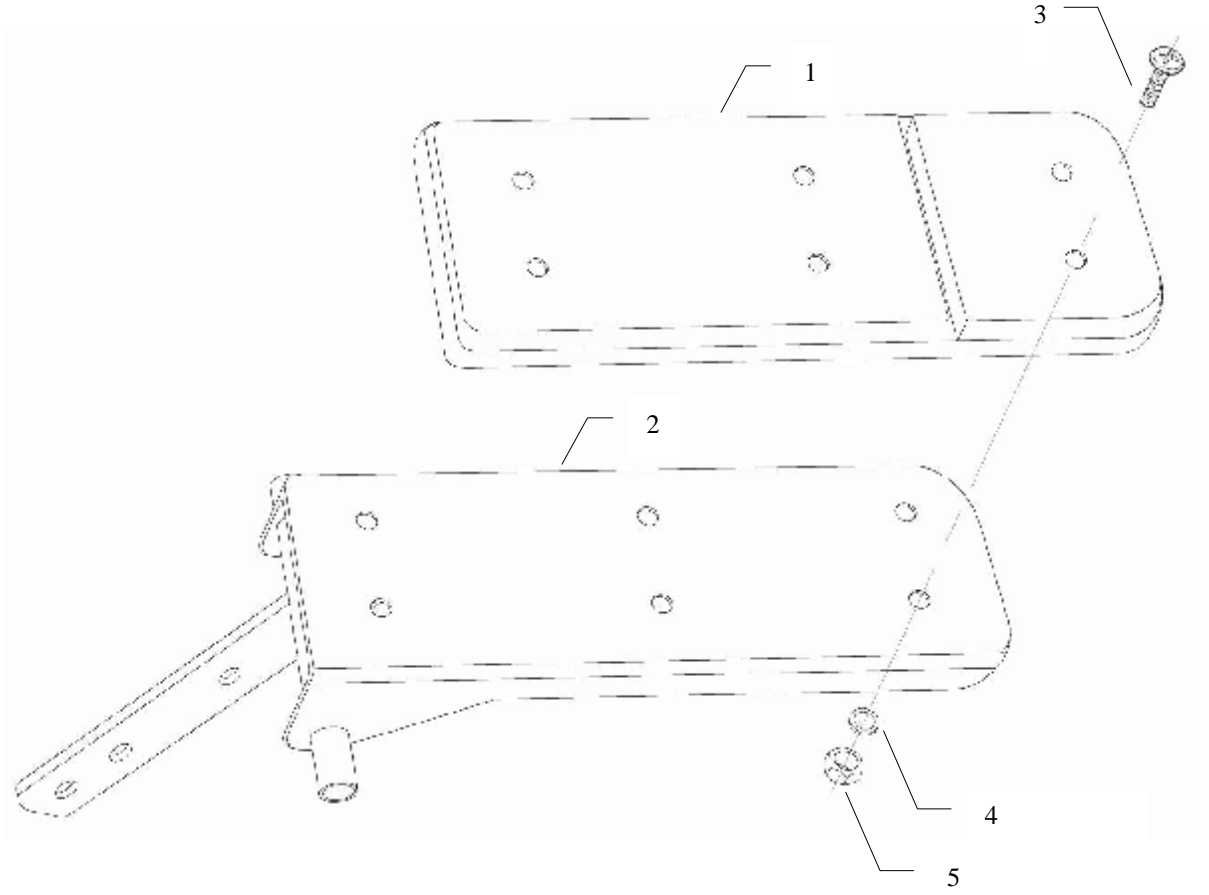

**12-2 Accelerator Pedal Assembly (加速踏板总成)**

Item	New Part No	Description	中文名称	Qty	Remark
1	1007022-004	Pad of accelerator pedal	加速器踏板软垫	1	
2	1007021-004	Accelerator pedal	加速器踏板总成	1	
3	Q2140616-304H	Cross slot bolt M6×16	十字槽盘头螺钉 M6×16	6	
4	Q40306-304H	Gasket spring M6	弹垫 M6	6	
5	Q340B06-304H	Nut M6	螺母 M6	6	

### 10-3 48V/12V DC Converter (DC 转换器)

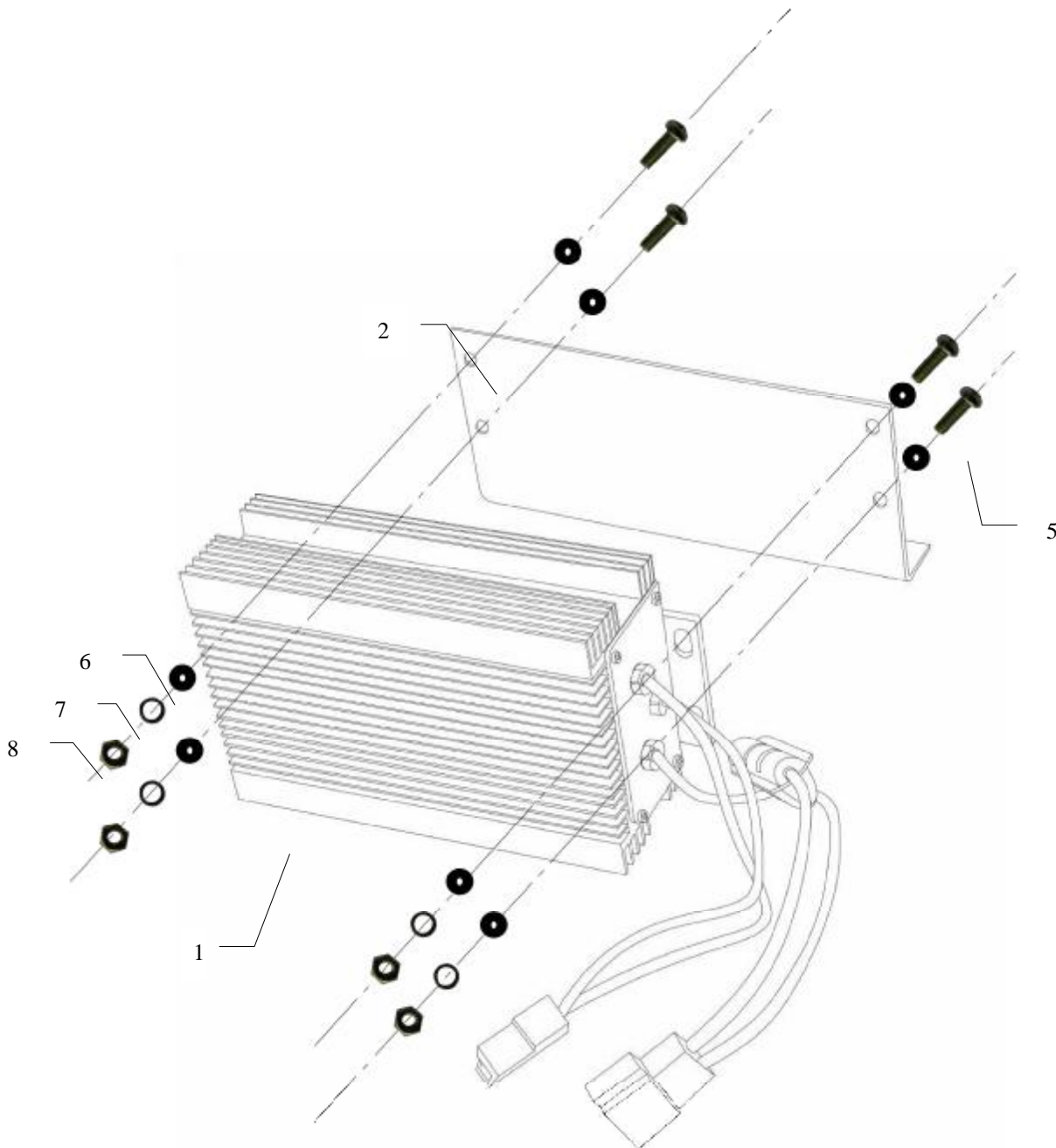

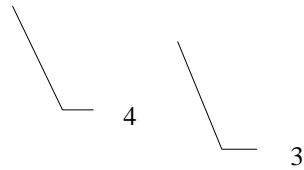

## 10-4 48V/12V DC Converter (DC 转换器)

Item	New Part No	Description	中文名称	Qty	Remark
1	3048100-001	48V/12V DC converter	48V/12V DC 转换器		
2	3048021-001	DC converter bracket	DC 转换器支架	1	
3		To out	接输入	1	
4		To 12V in	接 12V 输出	1	
5	Q174B0410-304H	Cross slot bolt M4×10	六角头头部带十字槽螺栓 M4×10	4	
6	Q40104-304H	Washer M4	平垫圈 M4	8	
7	Q40304-304H	Gasket spring M4	弹垫 M4	4	
8	Q340B04-304H	Nut M4	1 型六角螺母 M4	4	

## OPTION

A-1. 4-wheel hydraulic drum brake system

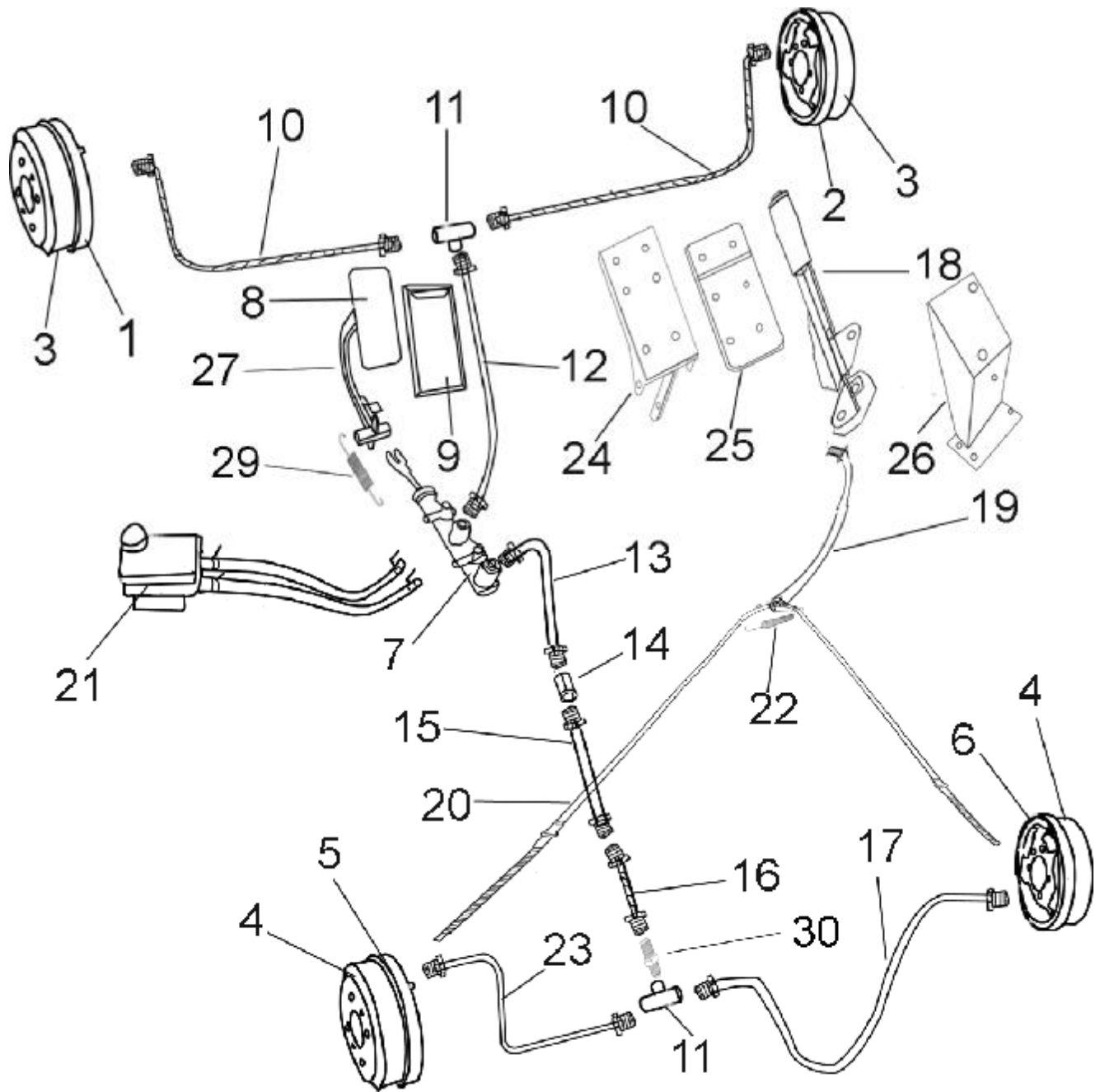

## 2) 4-wheel hydraulic drum brake system

Item	Part No	Description	中文名称	Qty	Remark
1	2801100-007	Front arrester, LH	左前制动器	1	



2	2801200-007	Front arrester, RH	右前制动器	1	
3	2801310-007	Front brake drum	前制动鼓	2	
4	2802310-006	Rear brake drum	后制动鼓	2	
5	2802100-006	Rear arrester, LH	左后制动器	1	
6	2802200-006	Rear arrester, RH	右后制动器	1	
7	2804100-022	Master cylinder	制动总泵带推杆总成	1	
8	2803100-037	Brake pedal	制动踏板总成	1	
9	2803111-036	Brake pedal pad	制动踏板软垫	1	
10	2805030-006	Brake tube	制动软管	2	
11	2805014-002	Tri-connector	三通	2	
12	2805020-009	Oil pipe 650mm	油管 650mm	1	
13	2805020-010	Oil pipe 1530mm	油管 1530mm	1	
14	2805016-001	Streight connector	直通	2	
15	2805020-005	Oil pipe 780mm	油管 780mm		
16	2805030-005	Rear brake tube	后液压制动软管总成	1	350mm
17	2805020-015	Oil pipe 930mm	油管 930mm	1	
18	2807100-002	Parking handle lever	手刹手柄	1	
19	2807200-007	No.1 parking tightwire	1号驻车钢索	1	
20	2807300-012	No.2 parking tightwire	2号驻车钢索	1	
21	2805040-002	Oil tank	制动油壶	1	
22	09443-15008	Return Spring	钢索回位弹簧	1	
23	2805020-014	Oil pipe 300mm	油管 300mm	1	
24	2044YY-1108010	Accelerator pedal	液压加速踏板	1	
25	1007022-004	Accelerator pedal pad	加速踏板软垫	1	
26	2807130-073	Handbrake bracket	手刹支架	1	
27	2803140-037	Brake pedal bracket	液压制动臂	1	
28					
29	6041-2803006	Return Spring for brake pedal	制动回位弹簧	1	
30	2805017-045	Transition connector	过渡接头	1	