



Economy Heavy Industrial

DWC HIN SERIES Polyurethane on Cast Iron Centre 100mm, 125mm, 150mm, 200mm



Capacity: 280 – 450KG per castor

- Double Ball Bearing Wheels
- Heavy Duty Welded Forks
- Polyurethane on Cast Iron Centre
- Robust Dual Metal Total Brake (ON/OFF)
- Applications for all industries : Transport, Food & Engineering Industries, Warehousing and many other applications

TYPE	CODE	WHEEL DIAMETER (MM)	TYRE WIDTH	WHEEL TYPE	BEARING TYPE	SWIVEL RADIUS MM	CAPACITY	HEIGHT (MM)
SWIVEL	HIN4S-CIPU	100 (4")	50	 Polyurethane	BALL	81	280	144
SWIVEL / BRAKE	HIN4SB-CIPU	100 (4")	50		BALL	129	280	144
FIXED	HIN4F-CIPU	100 (4")	50		BALL	81	280	144
SWIVEL	HIN5S-CIPU	125 (5")	50		BALL	96	350	165
SWIVEL / BRAKE	HIN5SB-CIPU	125 (5")	50		BALL	129	350	165
FIXED	HIN5F-CIPU	125 (5")	50		BALL	96	350	165
SWIVEL	HIN6S-CIPU	150 (6")	50		BALL	115	400	191
SWIVEL / BRAKE	HIN6SB-CIPU	150 (6")	50		BALL	141	400	191
FIXED	HIN6F-CIPU	150 (6")	50		BALL	115	400	191
SWIVEL	HIN8S-CIPU	200 (8")	50		BALL	150	450	242
SWIVEL / BRAKE	HIN8SB-CIPU	200 (8")	50		BALL	150	450	242
FIXED	HIN8F-CIPU	200 (8")	50		BALL	150	450	242

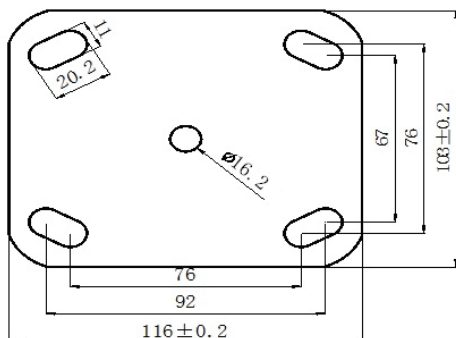

[Click here to view these products on our website!](#)