

# Smith Pump Company, Inc.



Pump & Pumping System Specialists Since 1962

**Waco**

Corporate Office  
301 M & B Industrial  
Waco, Tx. 76712  
(254) 776-0377

**Ft. Worth**

4624 Martin Luther King  
Freeway  
Ft. Worth, Tx. 76119  
(817) 589-2060

**Austin**

1900 West Howard  
Lane  
Austin, Tx. 78728  
(512) 310-1480

**San Antonio**

13126A Lookout  
Ridge  
San Antonio, Tx. 78233  
(210) 656-0530

**Houston**

5750 N. Sam Houston  
Pkwy E. Suite 1103  
Houston, Tx. 77032  
(713) 997-8647

[smithpump.com](http://smithpump.com)

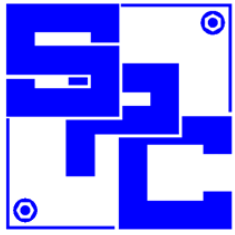

# SMITH PUMP COMPANY, INC.

Pump and  
Pumping  
System  
Specialists  
Since 1962

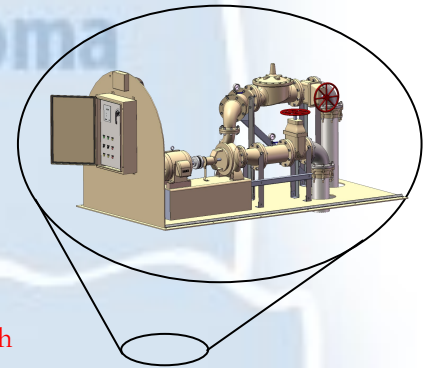
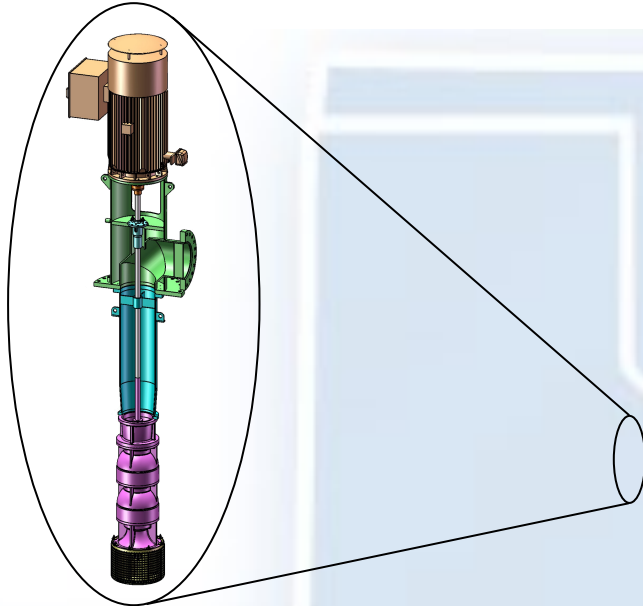

## Table of Contents

- Page 1 Cover
- Page 2 Table of Contents
- Page 3 History and Vision
- Page 4 Custom Systems for Water Applications
- Page 5 Custom Systems for Wastewater Applications
- Page 6 Fabrication Shop Services and Equipment
- Page 7 Pump Shop Services and Equipment
- Page 8 Field Services and Equipment
- Page 9 Field Testing Service and Equipment
- Page 10 Control Panel Shop
- Page 11 Computer Design Capability

Ft Worth



Waco



Austin



Houston



San Antonio

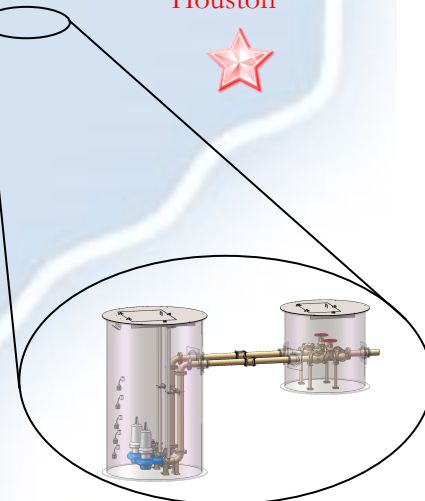
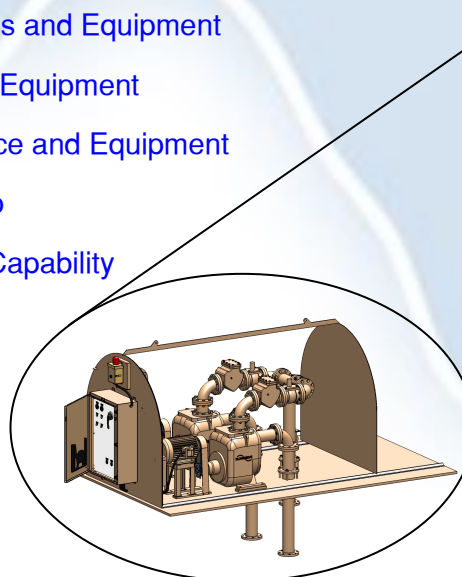



Our vision is to lead the industry with professional and friendly customer support

**Smith Pump Company was founded by Thomas G. Smith, PE, in 1962. We are a closely held private corporation, with five business locations, and have become a leader serving the water, wastewater and storm water market throughout Texas and Oklahoma.**

Our business is selling centrifugal pumps, parts, controls, repair, field service, related components and pump package manufacturing.

Smith Pump Company became ISO 9001-2008 certified in 2012 and is committed to continually meet or exceed customer satisfaction by providing quality products and services that comply with commitments and meet expectations. We continually improve our products, services and our quality management system in an effort to achieve this policy.

We train our employees in the application of pumping equipment for the water and wastewater markets. Our service department has the expertise, equipment and facilities to handle many problems that arise.

Each office is capable of providing customer support for product application of centrifugal pumps for municipal water and wastewater projects. Every office has field service support for equipment start-up, troubleshooting and field repair.

Smith Pump Company's corporate office is in Waco, Texas, and is located on 10 acres with 25,000 square feet under roof.





**Vertical Turbine Fabricated Steel Components**

Smith Pump specializes in engineered fabricated steel flanged column pipe, discharge heads and suction barrels for vertical turbine pumps in all sizes and for all applications. We blast and coat all components to your specific requirements in our Waco facility and we can meet your needs for vertical turbine applications.

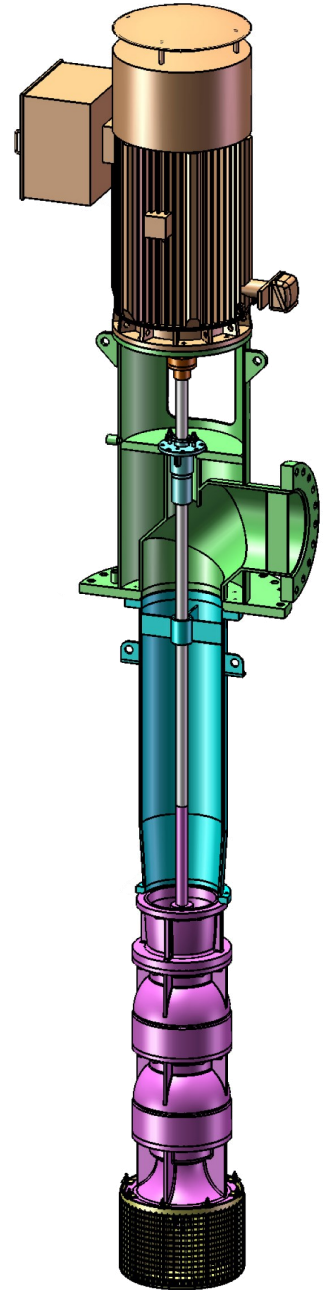
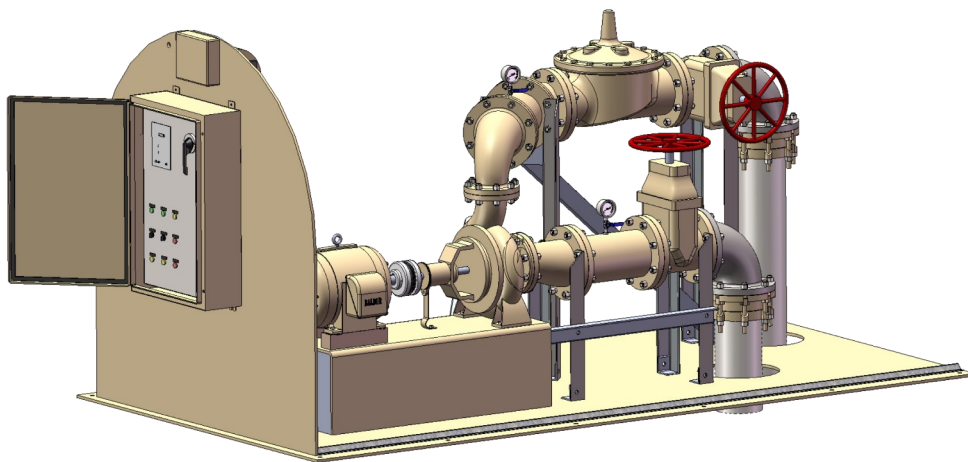

**Packaged Pump Stations**

We build complete, fabricated stations with end suction, horizontal split case double suction, vertical stacked and vertical turbine pumps including base, plumbing, controls, and enclosure.

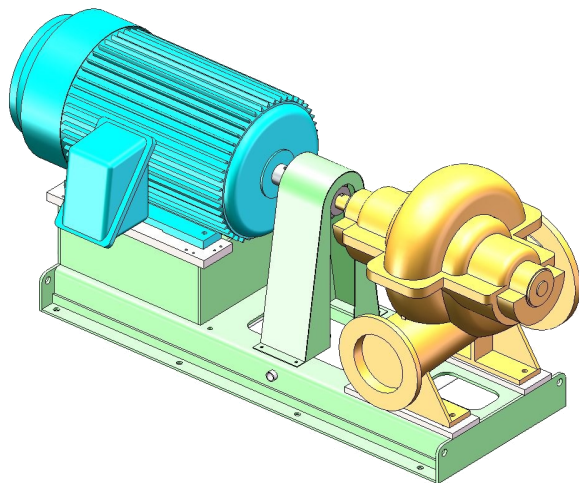

**Pump Bases**

Smith Pump Company designs and fabricates steel base plates the old fashioned way, with plenty of metal, to adequately support and maintain alignment between the pump and motor. Available options include weld stress-relieving before machining and motor jackscrew addition to facilitate alignment.

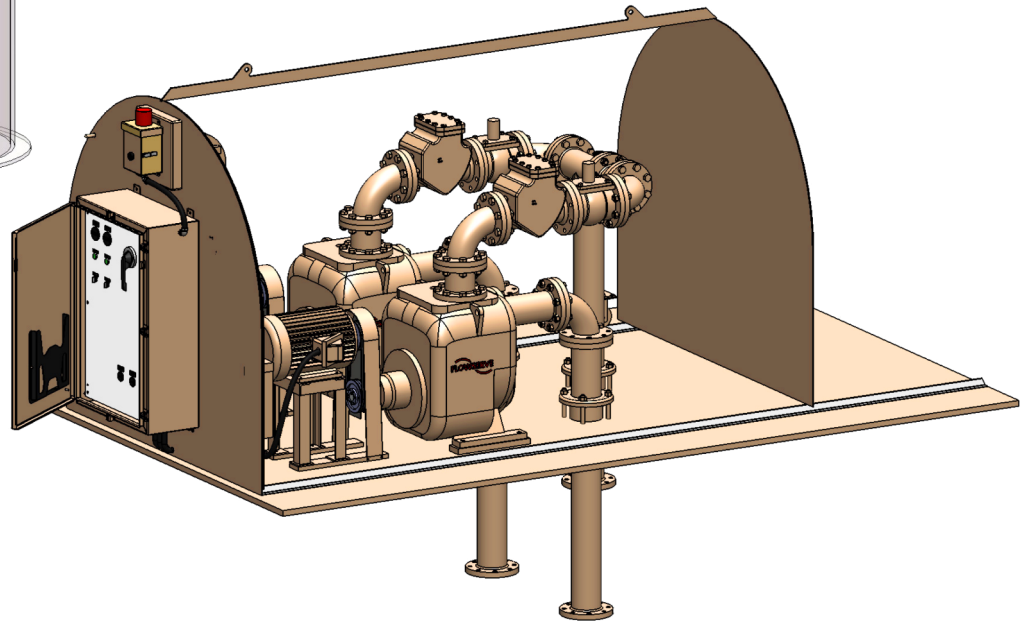
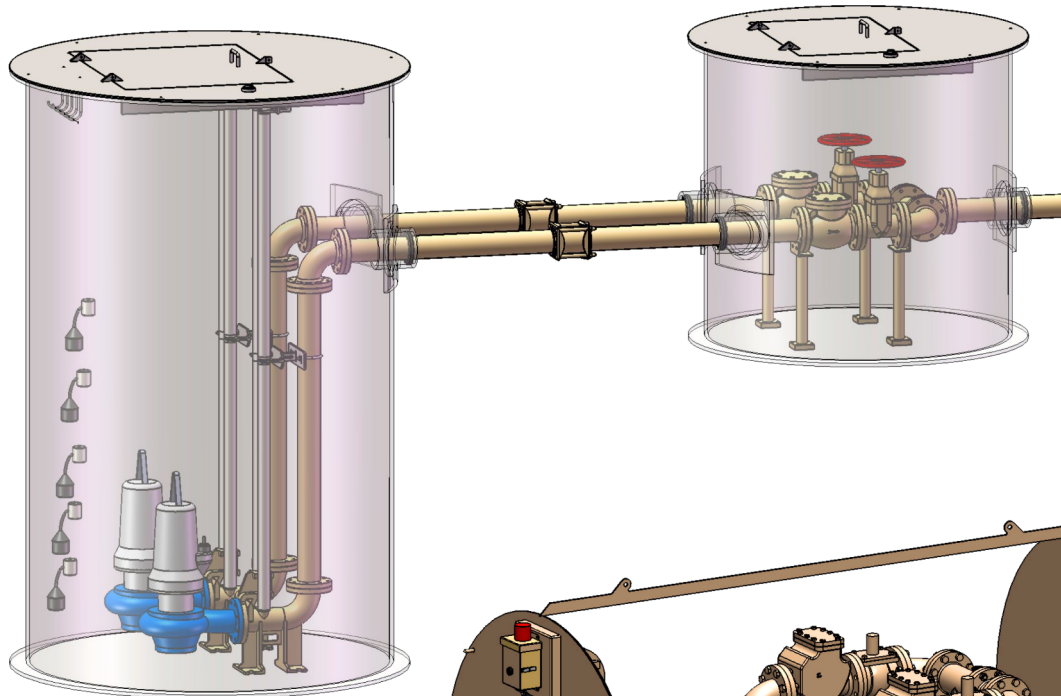

### Lift Station Packages

We provide submersible grinder pump stations, solids-handling lift stations in fiberglass wet wells and self-priming, solids-handling above ground stations including wet well, plumbing, valve vault, baseplate and controls, as required, to fit your needs.



Our experienced fabricators and certified welders build, assemble and repair a variety of pumps and pump-related components. A blast and paint facility puts on the finishing touches for a complete project.





No pump shop would be complete without a full machine shop and small pump repair bench. Our manual and CNC machinery coupled with our experienced operators allow Smith Pump Company to excel in small and large pump repairs.

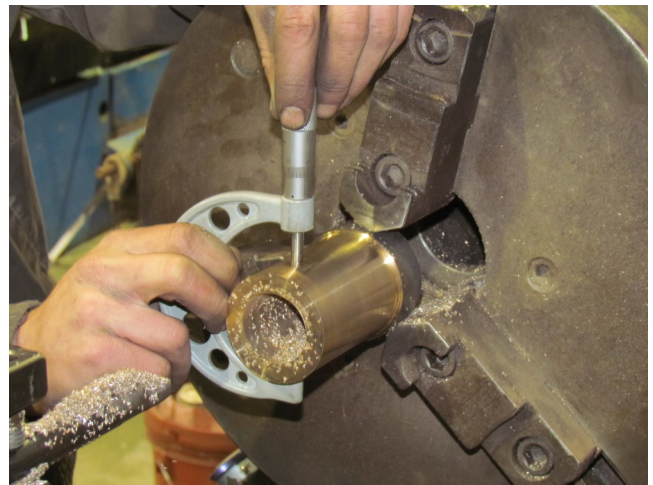



EXPERIENCED crews are available to provide the WELL PUMP SERVICE work on your installation. We are equipped to handle most installations and we are available 24 hours per day, 7 days per week.

This crew is preparing a 100 horsepower submersible turbine pump for installation 940 feet below ground.

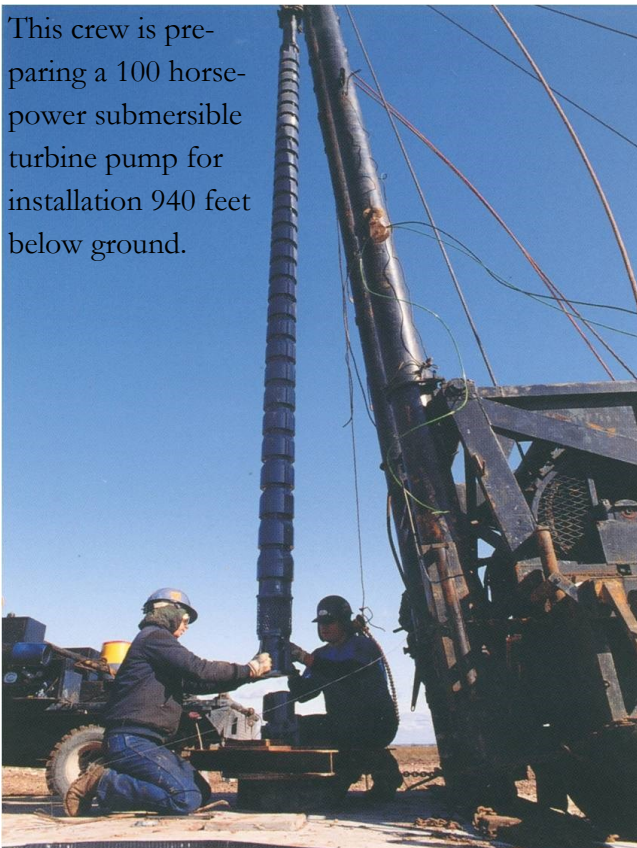





SMITH  
PUMP  
COMPANY, INC.

## Field Testing Services and Equipment



EXPERIENCED field service engineers and technicians are available to test new and existing pumps. We test the hydraulic conditions (flow rate, pressure and temperature), the mechanical conditions, level, and the vibration trending, vibration measurement and trim balancing using a Vibscanner.

We also perform machine vibration trending, analysis, and bearing conditions.





Smith Pump Company's Custom Panel Shop is UL508A approved and designs and builds panels to meet your needs.

### STANDARD OPTIONS AVAILABLE

NEMA 4X enclosure, padlock provision, circuit breaker, IEC contactor, bimetallic ambient-compensated overload relay, control circuit with H-O-A switch and run light terminals for all field wiring.

- Simplex
- Duplex
- Triplex
  
- Alarms (Audible & Visual)
- Telemetry
- Swing Dead Fronts
- Elapsed Time Meter
- Cycle Counter
- Lightning Suppression
- Phase Failure Protection
- Seal Failure Circuitry
- Heat Sensor Circuitry
- Anti Condensation Heater



INDUSTRIAL  
CONTROL PANEL  
E3414132





We fabricate raw water intakes for inline applications including intake tubes, filters, and suction barrels.

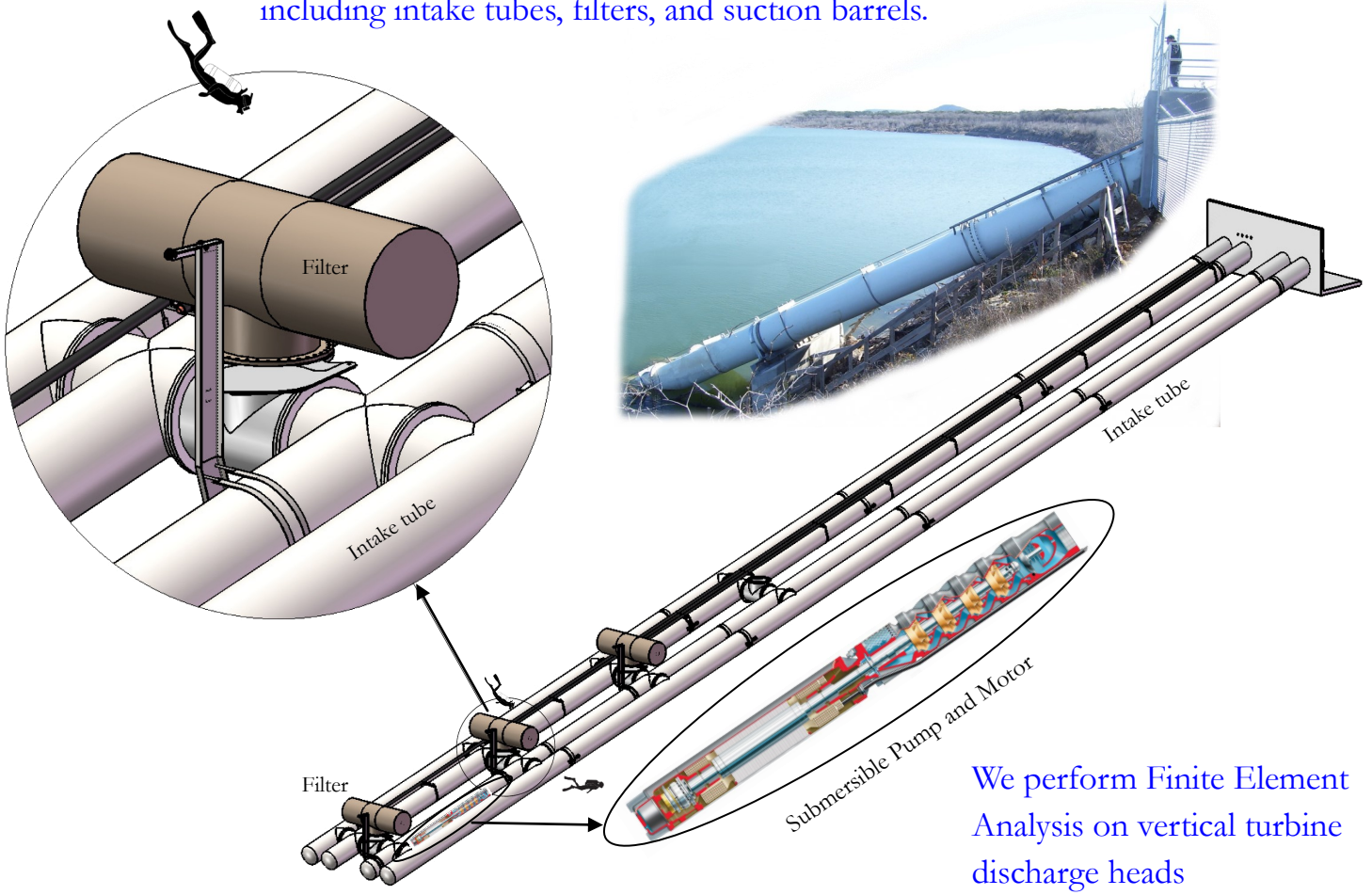

We perform Finite Element Analysis on vertical turbine discharge heads

We design and fabricate split ring and keyed couplings for vertical lineshaft turbines.

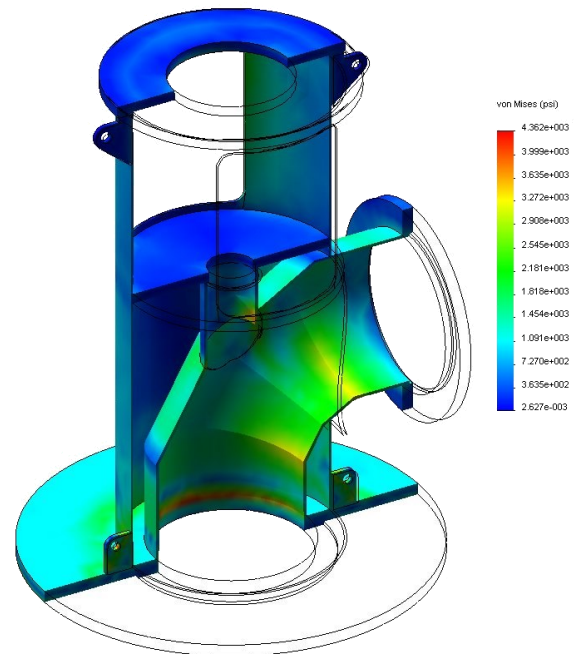
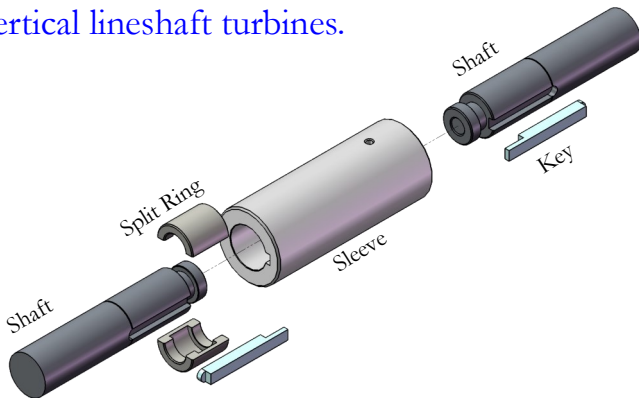

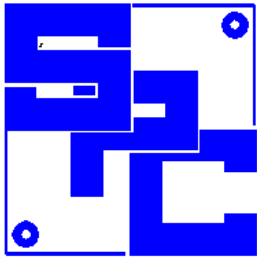

# Smith Pump Company

Pump & Pumping Systems Specialists Since 1962

Quality equipment that will meet or exceed your expectations first time and every time.



## PUMPS

- Horizontal Centrifugal
- Air Operated Diaphragm
- ANSI Process
- Submersible – Non-Clog
- Submersible – Turbine
- Submersible – Sump
- Submersible – Grinder
- Submersible – Cutter
- Submersible – Vortex
- Positive Displacement Gear
- Progressive Cavity
- Self-Priming
- Non-Clog Self-Priming
- Horizontal Split Case
- Vertical Turbine
- Regenerative Turbine



Centrilift



## MOTORS

- U.S. Electric (Nidec)
- TECO—Westinghouse
- General Electric
- Reliance—Baldor

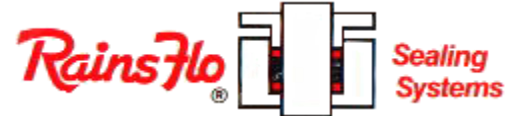

## CUSTOM SYSTEMS

- Lift Stations
- Packaged Pump Stations
- Custom Fabrication Packages
- Field Service & Repairs
- Technical Service
- Machine Shop Capabilities
- Wastewater Treatment Plants



### Waco

Corporate Office  
301 M & B Industrial  
Waco, Tx. 76712  
(254) 776-0377

### Ft. Worth

4624 Martin Luther King  
Freeway  
Ft. Worth, Tx. 76119  
(817) 589-2060

### Austin

1900 West Howard  
Lane  
Austin, Tx. 78728  
(512) 310-1480

### San Antonio

13126A Lookout  
Ridge  
San Antonio, Tx. 78233  
(210) 656-0530

### Houston

5750 N. Sam Houston  
Pkwy E. Suite 1103  
Houston, Tx. 77032  
(713) 997-8647