

TRADEWIND WORKSTATION FAN

The TradeWind fan is a productivity and space saving powerhouse. Designed to keep you cool and organized with a minimal footprint and ultra-portability. Equipped with our exclusive, selectable power-fin oscillation feature that continually spreads air flow horizontally throughout your workspace. Also features an integrated storage tray on the top of the fan for quick access to frequently used tools and supplies.

KEY FEATURES

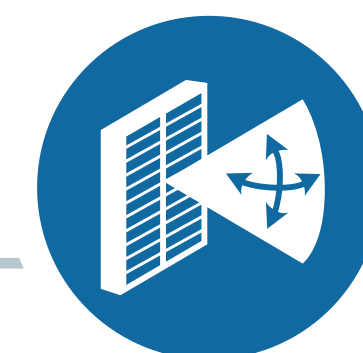

Power-Fin Oscillation

Electrically operated fins continually sweep airflow left to right for greater coverage



Variable Speed

Energy efficient, variable speed, totally enclosed motor for adjustable air flow



High Volume, Low Noise

High output 14,000 CFM poly fan blades. Ultra quiet with only 65 dB at 10'

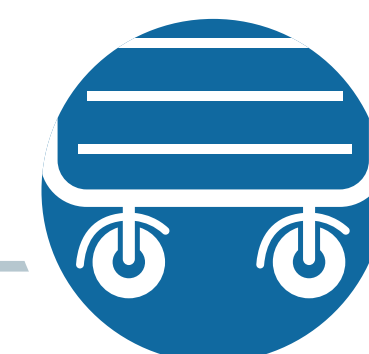

Nylon Casters

Soft-Touch nylon casters for ultra-portability and smooth movement





ZEPHYR TRADEWIND

WORKSTATION FAN



TECHNICAL SPECIFICATIONS

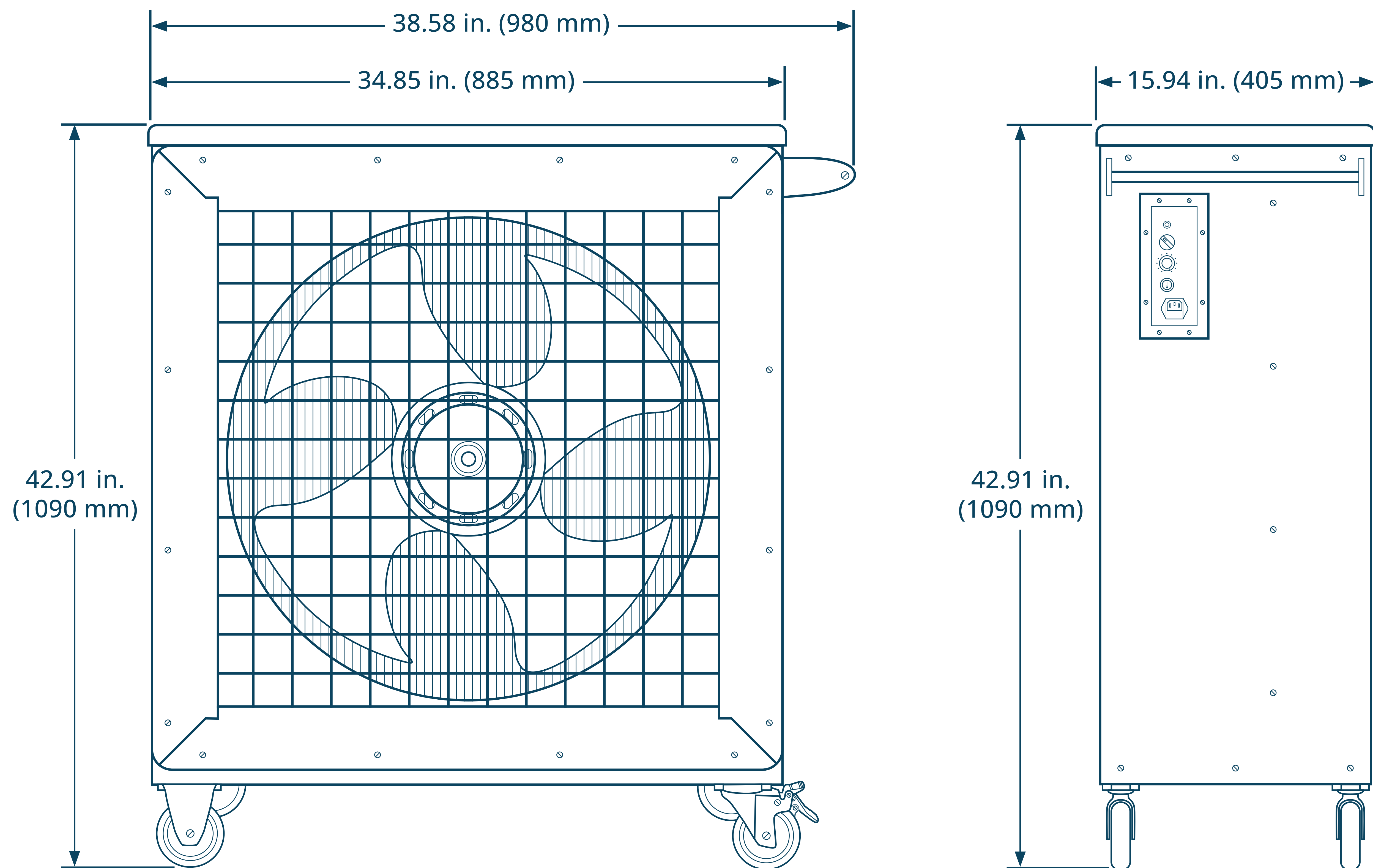

CFM	14,000
Type	Portable with Casters
Frame Material	Powder Coated Steel
Shutter Operation	Electrically operated horizontal shutters, manual vertical shutters
Fan Blades	28" 4 Nylon + Fiber Blades
Max RPM	850 RPM
Motor	650 W PMSM, Insulation Class F
Noise Rating	65dB @ 10'
Voltage	1 PH, 110V, 60HZ
Current	8.5A
Power Consumption	200 - 690 w/hr ±10%
Throw	Up to 82 ft
Dimensions	L38.58" x H42.91" x D 15.94"
Weight	80.47 lbs