

MODEL

# G122



Maximum filter life will be achieved with this product when one welder is welding up to 50 pounds of weld wire per week or grinding small weldments



**Capacity:** 1200 CFM @ 4.5 in.W.G.

**Motor:** 1.5 HP, Direct Drive

**Voltage:** Single phase, 110V, 60Hz

**Full Load Amps:** 20.0

**Blower:** Reverse inclined high performance blower wheel

**Sound Level:** 70 dBA

**Silencing:** Integral Acoustical Plenum with Low Frequency Dampening

**Controls:** Manual on/off switch, Minihelic Filter Condition Gauge

**Cabinet Dimensions (HxLxD):** 53" x 23" x 31"

**Weight:** 440 lbs.

**Filter Cartridge:** (1) EX-14D26-A15-SF

**Filter Media Area:** 256 sq.ft.

**Filter Type:** Nanofiber MERV15

**Filter Cleaning:** On board compressed air tank, manual activated push-button filter pulse cleaning, 1/4"NPT compressed air connection

**Dust Containment:** Lift-out Dust Tray

**Spark Arrestance:** (1) Metal Mesh Screen MM-20242

**Configuration:** (1) FlexDraft Attachment (Backdraft or Downdraft)

**Options:**

- Weld Current Sensor & Timer Module — VB-CST-2 (Onsite Install Required for all Optional Equipment)
- CSA Certification — CSA-100
- UL Certification — Contact Customer Service
- HEPA Filter & Frame : HP-S120 (required for attachment)
- HEPA Replacement Filter: HP-S120-HF (Note: HEPA filter reduces airflow by approximately 10%)

**Warranty:**

Visit [ventboss.com/terms](http://ventboss.com/terms) for full warranty details.

**FlexDraft in Backdraft Configuration**

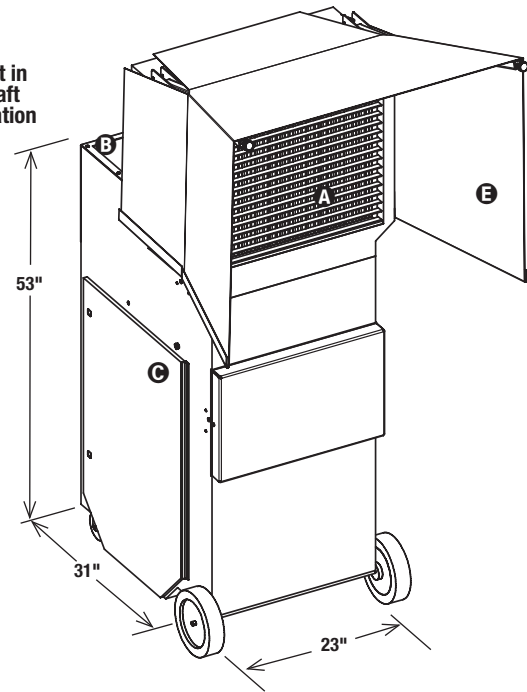

- A** Inlet Area
- B** Clean Air Exhaust
- C** Filter Access Door
- D** Motor/Blower Access
- E** Curtain Sides (increase smoke capture area)

**FlexDraft in Downdraft Configuration**

