

MODEL

G121



Maximum filter life will be achieved with this product when one or two welders are welding up to 50 pounds of weld wire per week.



- Capacity:** 1200 CFM @ 4.5 in.W.G.
- Motor:** 1.5 HP, Direct Drive
- Voltage:** Single phase, 110V, 60Hz
- Full Load Amps:** 20.0
- Blower:** Reverse inclined high performance blower wheel
- Sound Level:** 70 dBA
- Silencing:** Integral Acoustical Plenum with Low Frequency Dampening
- Controls:** Manual on/off switch, Minihelic Filter Condition Gauge
- Cabinet Dimensions (HxLxD):** 53" x 23" x 31"
- Weight:** 440 lbs.
- Filter Cartridge:** (1) EX-14D26-A15-SF
- Filter Media Area:** 256 sq.ft.
- Filter Type:** Nanofiber MERV15
- Filter Cleaning:** On board compressed air tank, manual activated push-button filter pulse cleaning, 1/4"NPT compressed air connection
- Dust Containment:** Lift-out Dust Tray
- Spark Arrestance:** (1) Metal Mesh Screen MM-20242
- Configurations:**
- **G121:** (2) 6" Diameter, 10' long FumeArm
- Options:**
- 6" FumeArm LED Light Kits — VB-HD-6LK (included)
 - Weld Current Sensor & Timer Module — VB-CST-2 (Onsite Install Required for all Optional Equipment)
 - CSA Certification — CSA-100
 - UL Certification — Contact Customer Service
 - HEPA Filter & Frame : HP-S120 (required for attachment)
 - HEPA Replacement Filter: HP-S120-HF (Note: HEPA filter reduces airflow by approximately 10%)
- Warranty:**
Visit ventboss.com/terms for full warranty details.

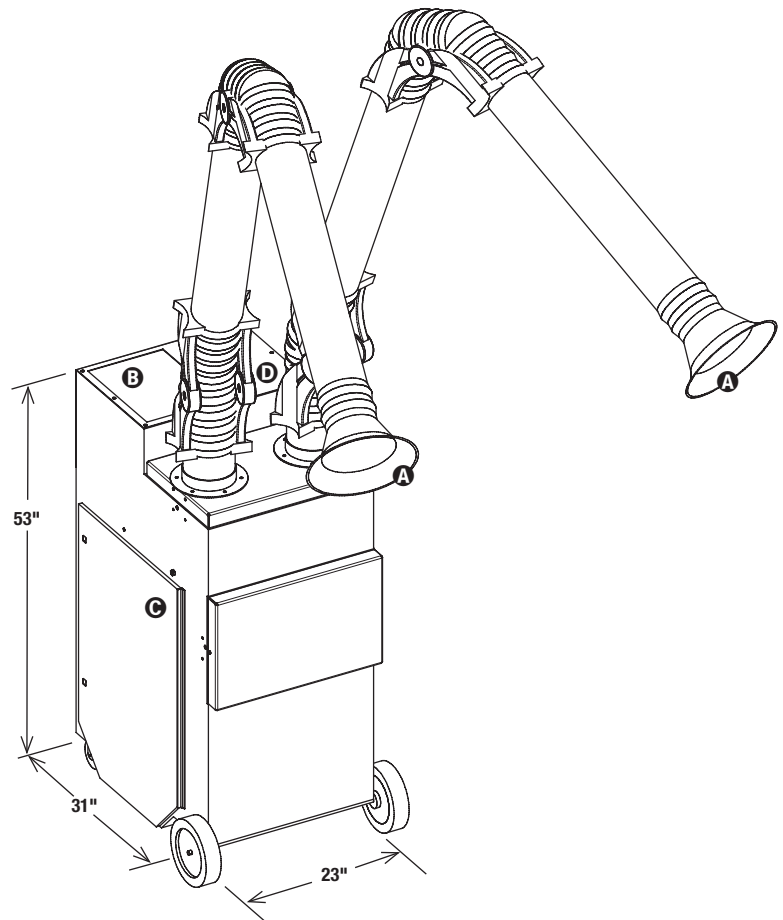

- Ⓐ Inlet Area
- Ⓑ Clean Air Exhaust
- Ⓒ Filter Access Door
- Ⓓ Motor/Blower Access