

### MODEL

# G112



Maximum filter life will be achieved with this product when one welder is welding up to 25 pounds of weld wire per week.



**Capacity:** 750 CFM @ 4.5 in.W.G.

**Motor:** 0.75 HP, Direct Drive

**Voltage:** Single phase, 110V, 50/60Hz

**Full Load Amps:** 13.8

**Blower:** Reverse inclined high performance blower wheel

**Sound Level:** 67 dBA

**Silencing:** Integral Acoustical Plenum with Low Frequency Dampening

**Controls:** Manual on/off switch, Minihelic Filter Condition Gauge

**Cabinet Dimensions (HxLxD):** 36" x 20" x 39"

**Weight:** 420 lbs.

**Filter Cartridge:** (1) EX-18D16-A15

**Filter Media Area:** 203 sq.ft.

**Filter Type:** Nanofiber MERV15

**Filter Cleaning:** Filter manual blow-out port

**Dust Containment:** Vacuum / sweep out filter plenum

**Spark Arrestance:** (1) Metal Mesh Screen MM-16202

**Configuration:** (1) 6" Diameter, 12' long FlexHose and Hood with Magnetic Base

#### Options:

- 6" FumeArm LED Light Kit — VB-HD-6LK (included)
- Weld Current Sensor & Timer Module — VB-CST-2 (Onsite Install Required for all Optional Equipment)
- CSA Certification — CSA-100
- UL Certification — Contact Customer Service
- HEPA Filter & Frame : HP-S110 (required for attachment)
- HEPA Replacement Filter: HP-S110-HF (Note: HEPA filter reduces airflow by approximately 10%)

#### Warranty:

Visit [ventboss.com/terms](http://ventboss.com/terms) for full warranty details.

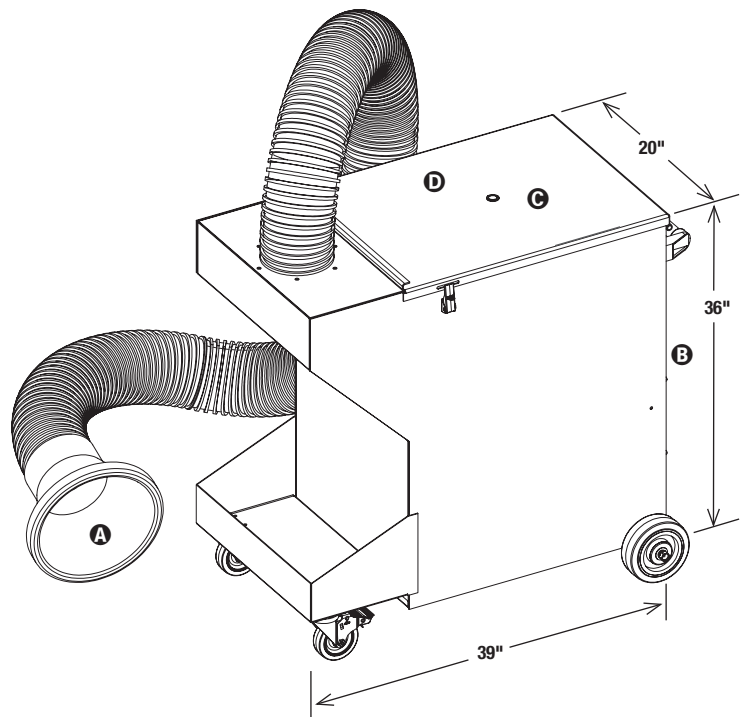

- Ⓐ Inlet Area
- Ⓑ Clean Air Exhaust (on back of unit)
- Ⓒ Filter Access Door
- Ⓓ Motor/Blower Access