

MODEL

G110



Maximum filter life will be achieved with this product when one welder is welding up to 25 pounds of weld wire per week.



Capacity: 750 CFM @ 4.5 in.W.G.

Motor: 0.75 HP, Direct Drive

Voltage: Single phase, 110V, 60Hz

Full Load Amps: 13.8

Blower: Reverse inclined high performance blower wheel

Sound Level: 67 dBA

Silencing: Integral Acoustical Plenum with Low Frequency Dampening

Controls: Manual on/off switch, Minihelic Filter Condition Gauge

Cabinet Dimensions (HxLxD): 36" x 20" x 39"

Weight: 445 lbs.

Filter Cartridge: (1) EX-18D16-A15

Filter Media Area: 203 sq.ft.

Filter Type: Nanofiber MERV15

Filter Cleaning: Filter manual blow-out port

Dust Containment: Vacuum / sweep out filter plenum

Spark Arrestance: (1) Metal Mesh Screen MM-16202

Configurations:

- **G110:** (1) 6" Diameter, 10' long Steel FumeArm

Options:

- 6" FumeArm LED Light Kit — VB-HD-6LK(included)
- Weld Current Sensor & Timer Module — VB-CST-2 (Onsite Install Required for all Optional Equipment)
- CSA Certification — CSA-100
- UL Certification — Contact Customer Service
- HEPA Filter & Frame : HP-S110 (required for attachment)
- HEPA Replacement Filter: HP-S110-HF (Note: HEPA filter reduces airflow by approximately 10%)

Warranty:

Visit ventboss.com/terms for full warranty details.

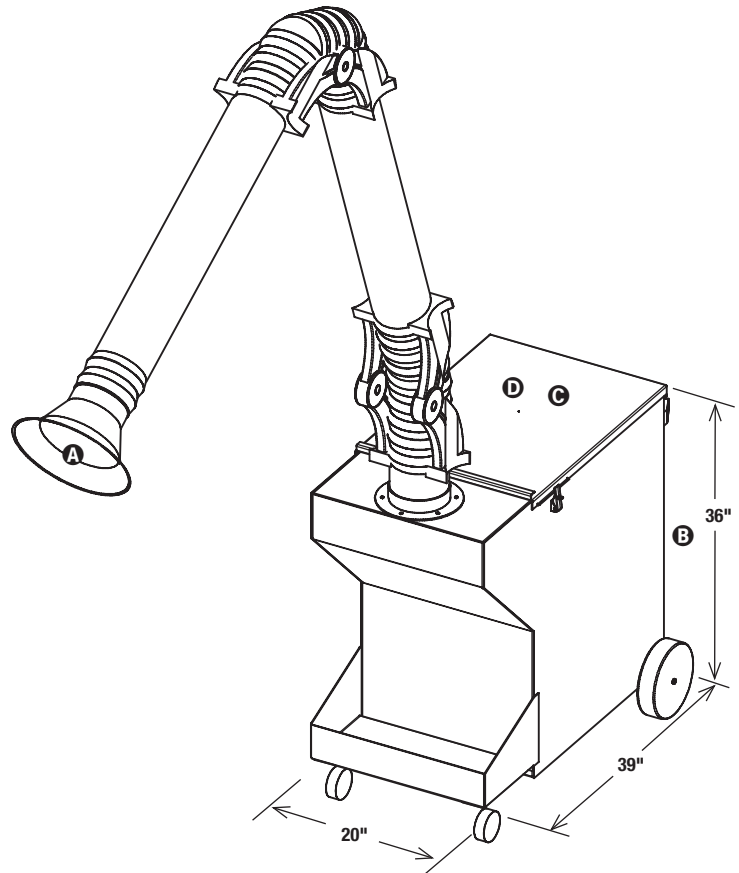

- Ⓐ Inlet Area
- Ⓑ Clean Air Exhaust (on back of unit)
- Ⓒ Filter Access Door
- Ⓓ Motor/Blower Access