



VCN Series

For High Static Pressure Application

OUTDOOR WALL-MOUNTED CENTRIFUGAL FANS



The VENTS VCN outdoor wall-mounted exhaust fan is ideal for residential and commercial applications where quiet and powerful exhaust is required and the space is limited. It allows powerful air extraction from one or more points and is suitable for connection to long duct runs. The external installation guarantees a noise-free solution for homes, offices, and commercial facilities. Fans have a casing made of steel with polymer coating and insect proof mesh. Motors are supplied with automatic reset thermal protection, and are equipped with ball bearings for longer service life (40,000 hrs). The VENTS VCN series fans have been specifically designed for simple installation and many years of maintenance free operation. The casing is removable for immediate access to the motor and wiring connections. VENTS VCN sizes range from 4" to 8", with airflows ranging up to 306 CFM. Low noise, smooth and reliable operation are the attributes of VENTS VCN centrifugal fans.

Application

- Bathroom exhaust
- Kitchen ventilation
- Living area
- Whole house ventilation
- Workshops & smoking areas
- Offices
- Bars & Restaurants
- Warehouses

Benefits

- High airflow and static pressure applications
- Quiet & efficient, vibration free operation
- Durable and corrosion resistant casing
- Durable, external rotor motor design
- Permanently lubricated ball bearing motors for maintenance-free operation
- Automatic reset thermal overload protection
- Casing can be easily removed for cleaning
- Rated for continuous operation
- Optimized efficiency, low maintenance costs
- ETL listed
- Five year warranty

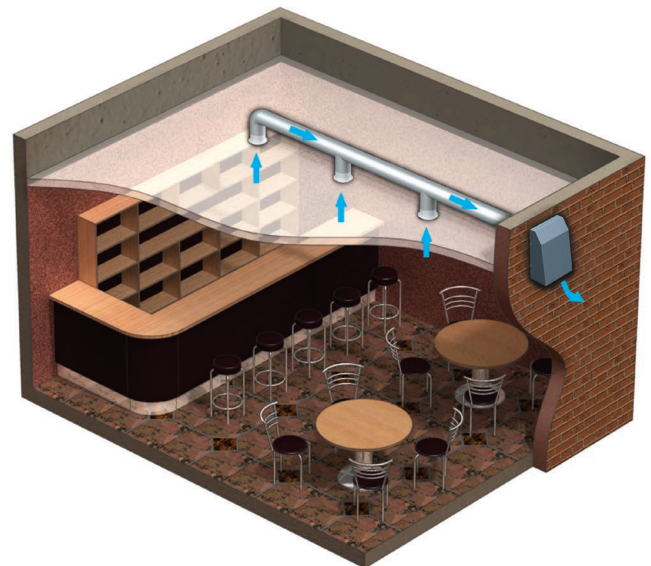

Bar ventilation example

Tel: 888-640-0925
513-348-3853
Fax: 513-268-4597

Sales@ventsus.com
VentsUS.com
11013 Kenwood Road,
Cincinnati, Ohio 45242



Dimensions

Model	Measurements [in.]				lbs
	ØD	H	B	L	
VCN 100	3 15/16"	14"	10 1/4"	5 7/16"	9.0
VCN 125	4 15/16"	14"	10 1/4"	5 7/16"	9.0
VCN 150	5 7/8"	15 3/4"	11 13/16"	5 7/16"	9.9
VCN 200	7 7/8"	15 3/4"	11 13/16"	5 7/16"	9.9

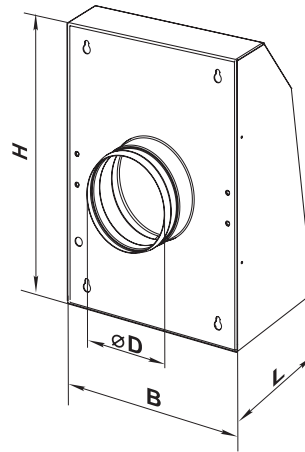

Performance

Model	Duct dia	CFM vs. Static Pressure (Ps) in WG					Sones	RPM*	Watts*
		0"	0.25"	0.5"	1.0"	1.5"			
VCN 100	4"	238	223	204	134	30	7.20	3100	108
VCN 125	5"	248	231	213	146	25	7.10	2950	108
VCN 150	6"	302	286	256	159	37	7.84	2250	109
VCN 200	8"	306	291	258	148	9	8.10	2300	106

* The parameters RPM, Watts are indicated at 0.2 in WG static pressure.

Specifications

Voltage: **120V 60Hz**

Motor: Single-phase external rotor motor with backward curved centrifugal impellers

Duct compatibility: **Ø 4", 5", 6", 8"**

Airflow capacity: up to **306 CFM**

Sones: **7.1 - 8.1**

Power consumption: **106 - 109 W**

Suitable for working airstreams up to **113° F**

IP X4 protection

Thermal overload protection

Five year warranty

Contacts

Tel: 888-640-0925

513-348-3853

Fax: 513-268-4597

Sales@ventsus.com

VentsUS.com

11013 Kenwood Road, Cincinnati, Ohio 45242

VENTS-US reserves the rights to modify any of its products features, designs, components, and specifications at any time and without notice to maintain the development and quality of manufactured goods.



Flow Chart Graphs can be viewed at www.vents-us.com/cat/505/