

TURBO TUBE SILENT SERIES

Quiet and Energy Efficient Inline Mixed Flow Fans



Ideal for bathrooms, kitchens, apartments, offices, libraries, education facilities, galleries and more.

Following the latest worldwide ventilation trends, we developed a new **INLINE MIXED FLOW FAN - TURBO TUBE SILENT** series - with super low noise and excellent aerodynamics.

TURBO TUBE SILENT fans provide ultra quiet operation & excellent airflow even in high-pressure systems. The specially designed and optimized case and the new aerodynamic mixed flow impeller ensure the highest performance.



FEATURES

- Quiet Operation: 0.6 – 2.5 Sones.
- High Performance - up to 327 CFM.
- Energy Efficient - 22 – 64 W.
- Duct Compatibility: 4", 5", 6".
- Compatible with high pressure system.
- Double Speed capacitor motor with thermal overload protection.
- Long-life ball bearing (up to 40,000 hours).
- Built-in 2-speed control switch & power cord.
- Rotary and removable central body for easy installation & maintenance.
- Compact size for limited spaces.
- Lightweight, durable and UV resistant plastic case (Flame rating - 5VA).
- Vibration free operation.
- Corrosion free.
- 5 year warranty.

PERFORMANCE SPECIFICATIONS

MODEL	ENERGY STAR CERTIFIED	SPEED	RPM*	SONES	DUCT DIA.	WATTS*	AMPS*	CFM VS. STATIC PRESSURE (Ps) IN WG											MAX Ps	VOLTS/Hz
								0"	0.1"	0.2"	0.3"	0.4"	0.5"	0.6"	0.7"	0.8"	0.9"	1.0"		
TT Silent 100	no	high	1994	1.5	4"	30	0.25	146	128	110	88	64	44	21	9	-	-	-	0.78	120V/60Hz
		low	1500	0.9		24	0.21	109	88	68	47	22	10	-	-	-	-	-	-	
TT Silent 125	yes	high	2059	1.3	5"	37	0.31	200	183	161	137	93	62	32	0	-	-	-	0.7	120V/60Hz
		low	1360	0.6		25	0.22	132	106	80	51	13	-	-	-	-	-	-	-	
TT Silent 150	yes	high	2617	2.5	6"	66	0.55	327	316	299	283	268	247	225	194	138	83	50	1.22	120V/60Hz
		low	1933	1.1		52	0.45	240	219	194	171	134	111	86	57	27	7	-	0.93	

* The parameters RPM, Watts, Amps are indicated at 0.2 in WG static pressure.

DIMENSIONS

MODEL	DIMENSIONS (Inches)				
	ØD	B	H	L	
TT Silent 100	3 13/16"	7 11/16"	8 15/16"	11 15/16"	3.4
TT Silent 125	4 13/16"	7 11/16"	8 15/16"	10 3/16"	3.3
TT Silent 150	5 13/16"	8 11/16"	9 3/4"	11 3/8"	4.6

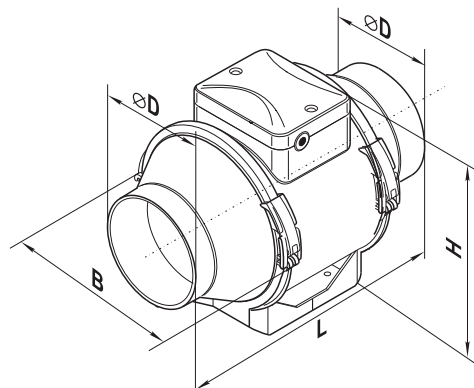

TURBO TUBE SILENT SERIES

Quiet and Energy Efficient Inline Mixed Flow Fans

INNOVATIVE DESIGN

AERODYNAMIC CASE

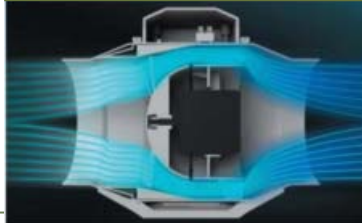

The diffuser, impeller and guide vanes provide a smooth laminar (non-turbulent) airflow that minimizes noise and generates excellent airflow in high pressure systems.

NEWLY DESIGNED IMPELLER



The hemispheric shaped impeller with specially profiled blades are designed to ensure super silent operation.

EASY TO INSTALL & CLEAN



The removable body, including motor, impeller and junction box, is the ultimate solution for easy installation & cleaning.

EASY CONNECTION



The removable body with the junction box can be rotated 180° to facilitate mounting and wiring.

BUILT-IN SPEED CONTROLLER



The double-speed motor is controlled with a built-in speed switch.

INTEGRATED MOUNTING BRACKET



The fan case is equipped with a mounting plate to attach the fan to the wall or ceiling.

EASY INSTALLATION



Fix the fan mounting plate on the flat surface.



Install the removable body inside the fan case.



Lock the removable body by clamps with latches.



Secure latches by screws.



Attach the ducts with clamps.



Insert the plug into electrical socket - the fan is READY to GO!



Select a required speed by the built-in speed switch. ENJOY the FRESH AIR.



No dismantling or disassembling! Just remove the central body from the case and complete the servicing!

ACCESSORIES

For more information on available accessories, see pages J8-J11 in Accessories & Motors section.