

TURBO TUBE TT SERIES

Powerful Mixed Flow Fans



Ideal for bathrooms, kitchens, apartments, restaurants, pools, offices, manufacturing facilities and more.

TURBO TUBE series fans are ideal solutions for multi-purpose use in residential and commercial ventilation. **TURBO TUBE** fans combine the features and benefits of both axial and centrifugal fans. Used for both supply and exhaust applications that require powerful airflow.

TURBO TUBE fans were engineered to be compact without any loss in performance and are the perfect solution for installation into limited spaces.

FEATURES

- Quiet Operation: 1.1 – 4.5 Sones
- High Performance - up to 1050 CFM
- Energy Efficient - 29.5 – 353 W
- Duct Compatibility: 4", 5", 6", 8", 10", 12 3/8"
- Double Speed capacitor motor with thermal overload protection
- Built-in speed control switch & power cord
- Lightweight, durable and UV resistant plastic case (UL94 certified plastic)
- 5 year warranty



Please see Performance Specifications table for Energy Star rated models.



PERFORMANCE SPECIFICATIONS

MODEL	ENERGY STAR CERTIFIED	SPEED	RPM*	SONES	DUCT DIA.	WATTS*	AMPS*	CFM VS. STATIC PRESSURE (Ps) IN WG								MAX Ps	VOLTS	
								0"	0.125"	0.2"	0.25"	0.5"	0.75"	1.0"	1.25"			1.5"
TT 100	no	high	3113	2.5	4"	36	0.45	105	49	37	32	13	-	-	-	-	0.7	120
		low	2818	1.1		29.5	0.37	62	41	30	23	2	-	-	-	-	0.54	120
TT 125	no	high	2600	2.5	5"	41	0.51	126	112	99	46	-	-	-	-	-	0.49	120
		low	2350	1.4		31	0.4	87	64	27	4	-	-	-	-	-	0.27	120
TT 150	yes	high	2033	3.5	6"	55	0.47	252	233	216	199	78	10	0	-	-	1.06	120
		low	1386	1.5		29.2	0.25	167	129	75	61	21	-	-	-	-	0.62	120
TT 200	yes	high	2116	4.5	8"	111	0.93	473	450	432	420	352	254	89	-	-	1.17	120
		low	1622	2		69.5	0.58	349	317	294	276	158	32	0	-	-	0.83	120
TT 250	no	high	2525	4.5	10"	200	1.68	880	873	866	862	842	816	708	450	323	2.27	120
		low	1925	2.5		130	1.11	655	646	630	620	565	480	330	115	10	1.54	120
TT 315	no	high	2419	4.5	12 3/8"	353	2.95	1051	1020	999	986	914	838	746	632	500	2.67	120
		low	1914	2.5		236	1.95	830	797	770	751	638	496	335	209	109	1.79	120

* The parameters RPM, Watts, Amps are indicated at 0.2 in WG static pressure.

INNOVATIVE DESIGN

AERODYNAMIC CASE

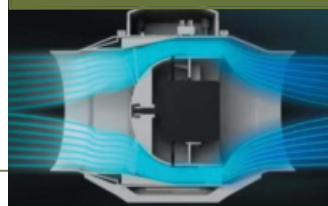

The motor and improved case shape provide high aerodynamic characteristics.

NEWLY DESIGNED IMPELLER



A specifically designed impeller provides smooth movement and powerful airflow.

EASY TO INSTALL & CLEAN



The Removable Body, including motor, impeller and junction box, is the ultimate solution for easy installation & cleaning.

EASY CONNECTION



The removable body with the junction box can be rotated 180° to facilitate mounting and wiring.

BUILT-IN SPEED CONTROLLER



The Double-speed motor is controlled with a Built-in Speed Switch.

INTEGRATED MOUNTING BRACKET



The fan case is equipped with a mounting plate to attach the fan to the wall or ceiling.

TURBO TUBE TT SERIES

Powerful Mixed Flow Fans



DIMENSIONS

MODEL	DIMENSIONS (Inches)					WEIGHT (lbs)
	ØD	ØD1	B	H	L	
TT 100	3 3/4"	5 1/2"	6 9/16"	7 1/2"	9 11/16"	3.1
TT 125	4 13/16"	5 1/2"	6 9/16"	7 1/2"	9 11/16"	3.1
TT 150	5 3/4"	7 11/16"	8 3/4"	9 13/16"	11 5/8"	6.6
TT 200	7 13/16"	8 1/4"	9 7/16"	10 1/4"	11 5/8"	14.1
TT 250	9 3/4"	10 1/8"	11 5/16"	12 11/16"	15 1/16"	18.3
TT 315	12 3/8"	12 11/16"	14 1/4"	16 1/16"	22 15/16"	25.1

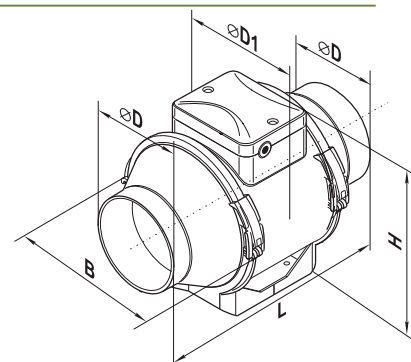

EASY INSTALLATION



Fix the fan mounting plate on the fl at surface.



Install the removable body inside the fan case.



Lock the removable body by clamps with latches.



Secure latches by screws.



Attach the ducts with clamps.



Insert the plug into electrical socket - the fan is READY TO GO!



Select a required speed by the built-in speed switch. ENJOY the FRESH AIR.



No dismantling or disassembling! Just remove the central body from the case and complete the servicing!

ACCESSORIES

For more information on available accessories, see pages J8-J11 in Accessories & Motors section.