

TF400 TRANQUIL BATHROOM FAN



Features & Benefits

- Totally enclosed brushless DC motor
- Ceiling mount design for commercial applications
- Superior ventilation and efficient performance
- Rugged 26 GA galvanized steel housing w/corrosion resistant finish
- Durable polymeric resin grille for long life
- Easy installation
- 4-point mounting capability
- Built-in backdraft damper
- 120V, 60 Hz operation
- Permanently lubricated motor for continuous operation
- Automatic reset thermal overload protection
- ETL listed for use over a tub/shower enclosure with GFCI circuit
- Fits 8" duct

TF400 Tranquil Bathroom Fan offers higher air delivery for commercial applications. The efficient DC motor is designed for continuous and quiet operation.

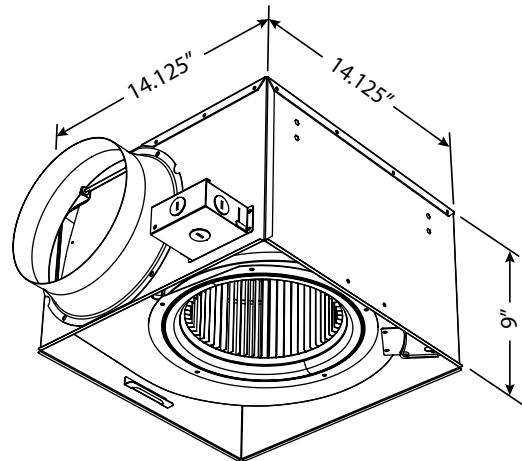
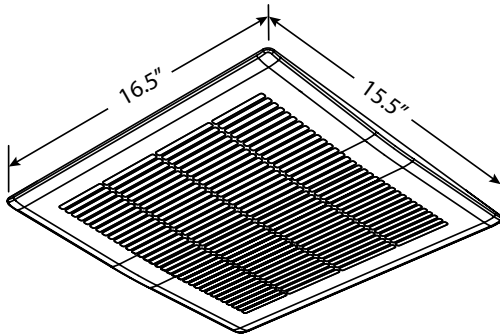

MODEL	PERFORMANCE			
	CFM 0.1" SP	CFM 0.25" SP	SONES	WATTS
TF400	400	390	3.0	40.0

DIMENSIONS IN INCHES*					
DUCT DIA.	GRILLE SIZE	HOUSING SIZE			SHIP WT (lbs)
		L	W	H	
8"	15.5 x 16.5	14.125	14.125	9.0	14

*DO NOT USE FOR CONSTRUCTION

CONSULT FACTORY FOR CERTIFIED PRINTS

